

4.3 Dimensions – AHU Kit

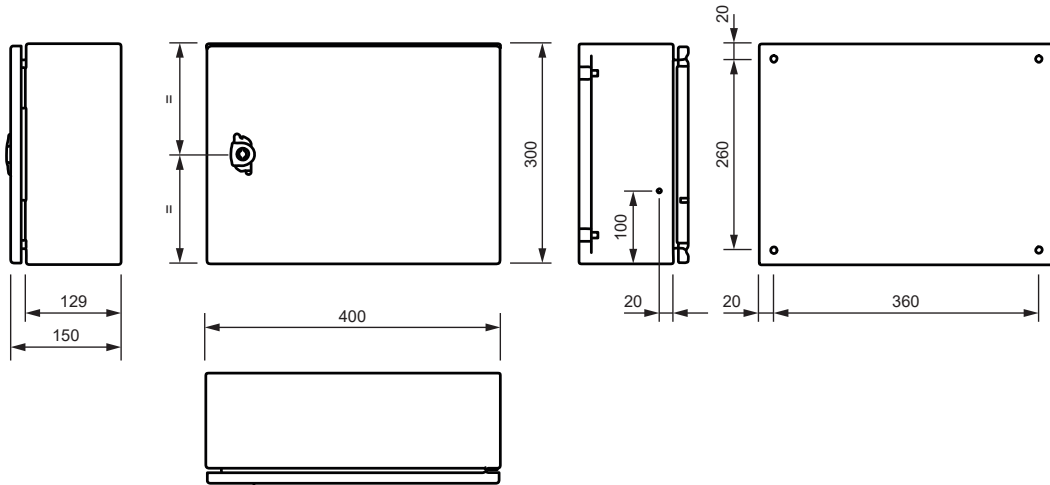

4.4 Technical specification – AHU Kit

PAW-P+100MAH4M technical data	Unit	Value
Power source	V / ph / Hz	220 ... 240 / 1 / 50
Rated current consumption	A	0,1
Rated power consumption (max.)	W	15
Dimensions (enclosure, W x H x D)	mm	400 x 300 x 150
Net weight (without valves)	kg	12.8
Ambient temperature (max.)	°C	45
Protection class	-	IP65

4.5 Power supply and connection cable between outdoor unit and AHU Kit

VRF 2-way outdoor unit (ECOi ME2 / MZ1, Mini ECOi LE1 / LE2 / LZ2)

1-phase outdoor unit

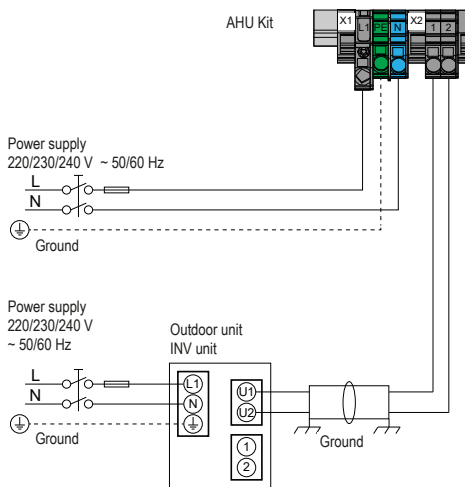

3-phase outdoor unit

