

Air-Conditioners For Building Application Indoor unit



PCFY-MS40VKM2-E PCFY-MS40VKM2-ET
PCFY-MS63VKM2-E PCFY-MS63VKM2-ET
PCFY-MS100VKM2-E PCFY-MS100VKM2-ET
PCFY-MS125VKM2-E PCFY-MS125VKM2-ET

English is original.

OPERATION MANUAL

FOR USER

English



Manual and DECLARATION OF CONFORMITY Download



<http://www.mitsubishielectric.com/ldg/ibim/>

- en** Go to the above website to download manuals and DECLARATION OF CONFORMITY, select model name, then choose language.
- de** Besuchen Sie die oben stehende Website, um Anleitungen und KONFORMITÄTSEKTLÄRUNGEN herunterzuladen, wählen Sie den Modellnamen und dann die Sprache aus.
- fr** Rendez-vous sur le site Web ci-dessus pour télécharger les manuels et les DÉCLARATIONS DE CONFORMITÉ, sélectionnez le nom de modèle puis choisissez la langue.
- nl** Ga naar de bovenstaande website om handleidingen en CONFORMITEITSVERKLARINGEN te downloaden, de modelnaam te selecteren en vervolgens de taal te kiezen.
- es** Visite el sitio web anterior para descargar manuales y DECLARACIONES DE CONFORMIDAD, seleccione el nombre del modelo y luego elija el idioma.
- it** Andare sul sito web indicato sopra per scaricare i manuali e le DICHIARAZIONI DI CONFORMITÀ, selezionare il nome del modello e scegliere la lingua.
- el** Μεταβείτε στον παραπάνω ιστότοπο για να κατεβάσετε εγχειρίδια και τις ΔΗΛΩΣΕΙΣ ΣΥΜΜΟΡΦΩΣΗΣ. Επιλέξτε το όνομα του μοντέλου και, στη συνέχεια, τη γλώσσα.
- pt** Aceda ao site Web acima indicado para descarregar manuais e DECLARAÇÕES DE CONFORMIDADE, seleccione o nome do modelo e, em seguida, escolha o idioma.
- da** Gå til ovenstående websted for at downloade manualer og OVERENSSTEMMELSESEKTLÆRINGER, vælg modelnavn, og vælg derefter sprog.
- sv** Gå till ovanstående webbplats för att ladda ner anvisningar och FÖRSÅKRINGAR OM ÖVERENSSTÄMMELSE, välj modellnamn och välj sedan språk.
- tr** Kılavuzları ve UYGUNLUK BEYANLARINI indirmek için yukarıdaki web sitesine gidin, model adını ve ardından dili seçin.
- ru** Чтобы загрузить руководства и ДЕКЛАРАЦИЮ СООТВЕТСТВИЯ, перейдите на указанный выше веб-сайт; выберите название модели, а затем язык.
- uk** Щоб завантажити керівництва та ДЕКЛАРАЦІЇ ВІДПОВІДНОСТІ НОРМАМ, перейдіть на зазначений вище вебсайт; виберіть назву моделі, а потім мову.
- bg** Посетете горепосочения уебсайт, за да изтеглите ръководства и ДЕКЛАРАЦИИ ЗА СЪОТВЕТСТВИЕ, като изберете име на модел и след това – език.
- pl** Odwiedź powyższą stronę internetową, aby pobrać instrukcje i DEKLARACJE ZGODNOŚCI, wybierz nazwę modelu, a następnie język.
- no** Gå til nettstedet over for å laste ned håndbøker og SAMSVARSEKTLÆRINGER, velg modellnavn, og velg deretter språk.
- fi** Mene yllä mainitulle verkkosivulle ladataksesi oppaat ja VAATIMUSTENMUKAISUUSVAKUUTUKSET, valitse mallin nimi ja valitse sitten kieli.
- cs** Příručky a PROHLÁŠENÍ O SHODĚ naleznete ke stažení na internetové stránce zmíněné výše poté, co zvolíte model a jazyk.
- sk** Na webovej stránke vyššie si môžete stiahnuť návody a VYHLÁŠENIA O ZHODE. Vyberte názov modelu a zvolte požadovaný jazyk.
- hu** A kézikönyvek és a MEGFELELŐSÉGI NYILATKOZATOK letöltéséhez látogasson el a fenti weboldalra, válassza ki a modell nevét, majd válasszon nyelvet.
- sl** Obiščite zgornjo spletno stran za prenos priročnikov in IZJAV O SKLADNOSTI, izberite ime modela, nato izberite jezik.
- ro** Accesați site-ul web de mai sus pentru a descărca manualele și DECLARAȚIILE DE CONFORMITATE, selectați denumirea modelului, apoi alegeți limba.
- et** Kasutusjuhendite ja VASTAVUSDEKLARATSIOONIDE allalaadimiseks minge ülaltoodud veebilehele, valige mudeli nimi ja seejärel keel.
- lv** Dodieties uz iepriekš norādīto tīmekļa vietni, lai lejupielādētu rokasgrāmatas un ATBILSTĪBAS DEKLARĀCIJAS; tad izvēlieties modeļa nosaukumu un valodu.
- lt** Norėdami atsisiųsti vadovus ir ATITIKTIES DEKLARACIJAS, apsilankykite pirmiau nurodytoje žiniatinklio svetainėje, pasirinkite modelio pavadinimą, tada – kalbą.
- hr** Kako biste preuzeli priručnike i IZJAVE O SUKLADNOSTI, idite na gore navedeno web-mjesto, odaberite naziv modela, a potom odaberite jezik.
- sr** Idite na gore navedenu veb stranicu da biste preuzeli uputstva i IZJAVE O USAGLAŠENOSTI, izaberite ime modela, a zatim izaberite jezik.

1. Safety Precautions	1	6. Care and Cleaning.....	12
2. Parts Names.....	3	7. Troubleshooting.....	13
3. Operation.....	7	8. Specifications	15
4. Timer.....	11	9. Maintenance	16
5. Emergency Operation for Wireless Remote-controller.....	11		



Note

Fig. 1

This symbol mark is for related countries only.

This symbol mark is according to the directive 2012/19/EU Article 14 Information for users and Annex IX, and/or to the regulation (EU) 2023/1542 Article 74 Information for end-users and Annex VI.

Your MITSUBISHI ELECTRIC product is designed and manufactured with high quality materials and components which can be recycled and/or reused. This symbol means that electrical and electronic equipment, batteries and accumulators, at their end-of-life, should be disposed of separately from your household waste. If a chemical symbol is printed beneath the symbol (Fig. 1), this chemical symbol means that the battery or accumulator contains a heavy metal at a certain concentration.

This will be indicated as follows: Hg: mercury (0.0005%), Cd: cadmium (0.002%), Pb: lead (0.004%)

In the European Union there are separate collection systems for used electrical and electronic products, batteries and accumulators.

Please, dispose of this equipment, batteries and accumulators correctly at your local community waste collection/recycling centre.

Please, help us to conserve the environment we live in!

Note:

The phrase "Wired remote controller" in this operation manual refers to the PAR-42MAAB.

If you need any information for the other remote controller, please refer to the instruction book included in this box.

1. Safety Precautions

- ▶ Before installing the unit, make sure you read all the "Safety Precautions".
- ▶ The "Safety Precautions" provide very important points regarding safety. Make sure you follow them.
- ▶ Please report to or take consent by the supply authority before connection to the system.
- ▶ This unit is equipped with a leak detection system for safety. For leak detection to be effective, the unit must be electrically powered at all times after installation, other than when servicing.

MEANINGS OF SYMBOLS DISPLAYED ON THE UNIT

	WARNING (Risk of fire)	This mark is for R32 refrigerant only. Refrigerant type is written on nameplate of outdoor unit. In case that refrigerant type is R32, this unit uses a flammable refrigerant. If refrigerant leaks and comes in contact with fire or heating part, it will create harmful gas and there is risk of fire.
		Read the OPERATION MANUAL carefully before operation.
		Service personnel are required to carefully read the OPERATION MANUAL and INSTALLATION MANUAL before operation.
		Further information is available in the OPERATION MANUAL, INSTALLATION MANUAL, and the like.

Symbols used in the text

Warning:

Describes precautions that should be observed to prevent danger of injury or death to the user.

Caution:

Describes precautions that should be observed to prevent damage to the unit.

Symbols used in the illustrations

:Indicates a part which must be grounded.

Warning:

- These appliances are not accessible to the general public.
- The unit must not be installed by the user. Ask the dealer or an authorized company to install the unit. If the unit is installed improperly, water leakage, electric shock or fire may result.
- Do not alter the unit. It may cause fire, electric shock, injury or water leakage.
- Do not stand on, or place any items on the unit.
- Install the unit at a place that can withstand its weight.
- Do not splash water over the unit and do not touch the unit with wet hands. An electric shock may result.
- Do not spray combustible gas close to the unit. Fire may result.
- Do not place a gas heater or any other open-flame appliance where it will be exposed to the air discharged from the unit. Incomplete combustion may result.
- Do not remove the front panel or the fan guard from the outdoor unit when it is running.

- Never repair the unit or transfer it to another site by yourself.
- When you notice exceptionally abnormal noise or vibration, stop operation, turn off the power switch, and contact your dealer.
- Never insert fingers, sticks etc. into the intakes or outlets.
- If you detect odd smells, stop using the unit, turn off the power switch and consult your dealer. Otherwise, a breakdown, electric shock or fire may result.
- This air conditioner is NOT intended for use by children or infirm persons without supervision.
- If the refrigeration gas blows out or leaks, stop the operation of the air conditioner, thoroughly ventilate the room, and contact your dealer.
- This appliance is intended to be used by expert or trained users in shops, in light industry, or for commercial use by lay persons.

1. Safety Precautions

- This appliance is not intended for use by persons (including children) with reduced physical, sensory or mental capabilities, or lack of experience and knowledge, unless they have been given supervision or instruction concerning use of the appliance by a person responsible for their safety.
- Children should be supervised to ensure that they do not play with the air conditioner.
- This appliance can be used by children aged from 8 years and above and persons with reduced physical, sensory or mental capabilities or lack of experience and knowledge if they have been given supervision or instruction concerning use of the appliance in a safe way and understand the hazards involved. Children shall not play with the appliance. Cleaning and user maintenance shall not be made by children without supervision.
- When installing or relocating, or servicing the air conditioner, use only the specified refrigerant written on outdoor unit to charge the refrigerant lines. Do not mix it with any other refrigerant and do not allow air to remain in the lines.
If air is mixed with the refrigerant, then it can be the cause of abnormal high pressure in the refrigerant line, and may result in an explosion and other hazards.
The use of any refrigerant other than that specified for the system will cause mechanical failure or system malfunction or unit breakdown. In the worst case, this could lead to a serious impediment to securing product safety.
- Replace the refrigerant sensor when the remote controller displays refrigerant leakage error “1521, 1522 or 1524” or refrigerant sensor failure “5558”. Please contact the store where you purchased the product. Continuing to use a refrigerant sensor that cannot detect refrigerant leaks can cause a fire in the event of a refrigerant leak.
- Do not turn the breaker OFF except the case of burning smell, or when performing maintenance or inspection.
The power cannot be supplied to the refrigerant sensor mounted in the indoor unit, and the sensor cannot detect the refrigerant leakage. This may cause a fire.
- Maintenance, service and repair operations shall be performed by authorized technician with required qualification.
- This unit should be installed in rooms which exceed the floor space specified in outdoor unit installation manual. Refer to outdoor unit installation manual.
- Do not use means to accelerate the defrosting process or to clean, other than those recommended by the manufacturer.
- The appliance shall be stored in a room without continuously operating ignition sources (for example: open flames, an operating gas appliance or an operating electric heater).
- Do not pierce or burn.
- Be aware that refrigerants might not contain an odour.

en

⚠ Caution:

- Do not use any sharp object to push the buttons, as this may damage the remote controller.
- Never block or cover the indoor or outdoor unit's intakes or outlets.
- Never wipe the remote controller with benzene, thinner chemical rags, etc.
- Do not operate the unit for a long time in high humidity, e.g. leaving a door or window open. In the cooling mode, if the unit is operated in a room with high humidity (80% RH or more) for a long time, water condensed in the air conditioner may drop and wet or damage furniture, etc.
- Do not touch the upper air outlet vane or the lower air outlet damper during operation. Otherwise, condensation may form and the unit may stop operating.
- Refrigerant leakage may cause suffocation. Provide ventilation in accordance with EN378-1.
- Be sure to wrap insulation around the piping. Direct contact with the bare piping may result in burns or frostbite.
- Never put batteries in your mouth for any reason to avoid accidental ingestion.
- Battery ingestion may cause choking and/or poisoning.
- Install the unit on a rigid structure to prevent excessive operation sound or vibration.
- Noise measurement is carried out in accordance with JIS C9612, JIS B8616, ISO 5151(T1), and ISO 13523(T1).
- Do not install the unit in a place where smoke, gas, or chemicals may fill.
The refrigerant sensor mounted in the indoor unit may react to it, and display an error of refrigerant leakage.

Disposing of the unit

When you need to dispose of the unit, consult your dealer.

2. Parts Names

Indoor Unit

Fan speed		4 speed+ Auto*1
Vane	Steps	5 steps
	Auto swing	Available
Louver		Manual
Filter		Long-life
Filter cleaning indication		2,500 hr
Wireless remote controller model No. setting*2		065 (001)

*1 This operation is available only using the remote controller that is able to set its Fan speed setting "Auto".

*2 Set the "Model No." for a wireless remote controller when using it. (Refer to the table above.)

- Set the Model No. to the No. in the parentheses when an outdoor unit is the simultaneous operation cooling and heating model (models whose operation mode can be selected to Auto mode.).
- See the installation manual of the wireless remote controller for the method of setting the Model No. for a wireless remote controller.

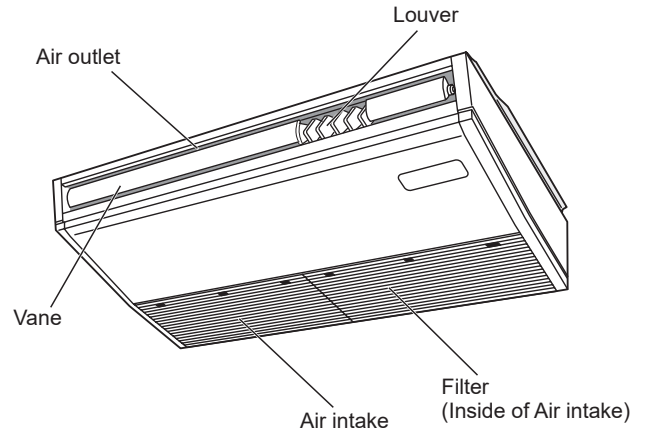

Wired Remote Controller

Controller interface

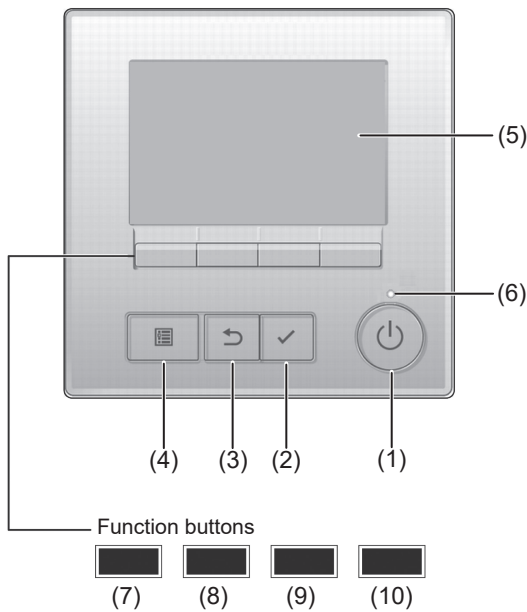

The functions of the function buttons change depending on the screen.

Refer to the button function guide that appears at the bottom of the LCD for the functions they serve on a given screen.

When the system is centrally controlled, the button function guide that corresponds to the locked button will not appear.

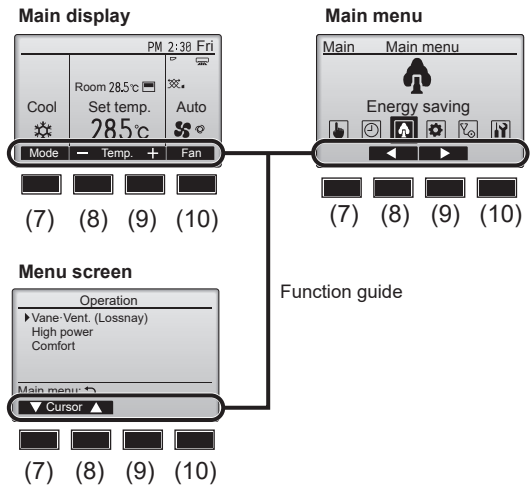

(1) [ON/OFF] button

Press to turn ON/OFF the indoor unit.

(2) [SELECT] button

Press to save the setting.

(3) [RETURN] button

Press to return to the previous screen.

(4) [MENU] button

Press to bring up the Main menu.

(5) Backlit LCD

Operation settings will appear.

When the backlight is off, pressing any button turns the backlight on and it will stay lit for a certain period of time depending on the screen.

When the backlight is off, pressing any button turns the backlight on and does not perform its function. (except for the [ON/OFF] button)

(6) ON/OFF lamp

This lamp lights up in green while the unit is in operation. It blinks while the remote controller is starting up or when there is an error.

(7) Function button [F1]

Main display: Press to change the operation mode.

Menu screen: The button function varies with the screen.

(8) Function button [F2]

Main display: Press to decrease temperature.

Main menu: Press to move the cursor left.

Menu screen: The button function varies with the screen.

(9) Function button [F3]

Main display: Press to increase temperature.

Main menu: Press to move the cursor right.

Menu screen: The button function varies with the screen.

(10) Function button [F4]

Main display: Press to change the fan speed.

Menu screen: The button function varies with the screen.

2. Parts Names

Display

The main display can be displayed in two different modes: "Full" and "Basic". The factory setting is "Full". To switch to the "Basic" mode, change the setting on the Main display setting. (Refer to operation manual included with remote controller.)

<Full mode>

* All icons are displayed for explanation.

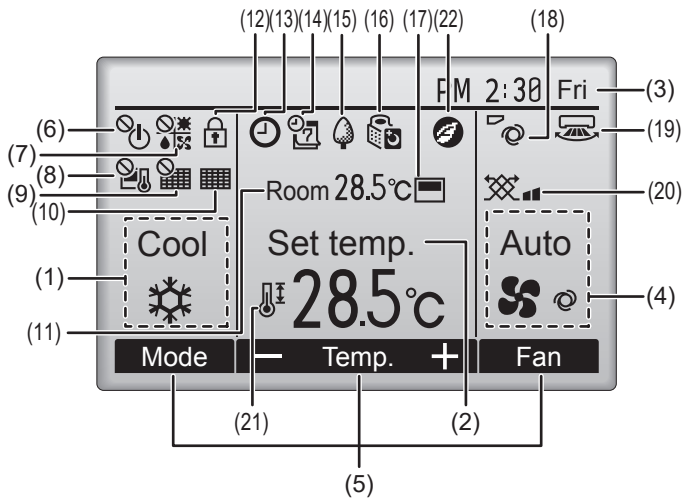

<Basic mode>

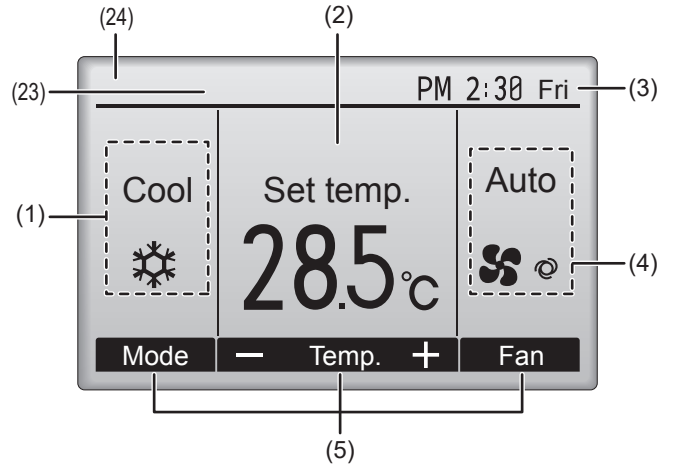

(1) Operation mode

(2) Preset temperature

(3) Clock

(4) Fan speed

(5) Button function guide

Functions of the corresponding buttons appear here.



Appears when the ON/OFF operation is centrally controlled.



Appears when the operation mode is centrally controlled.



Appears when the preset temperature is centrally controlled.



Appears when the filter reset function is centrally controlled.



Indicates when filter needs maintenance.

(11) Room temperature



Appears when the buttons are locked.



Appears when the On/Off timer, Night setback, or Auto-off timer function is enabled.

appears when the timer is disabled by the centralized control system.

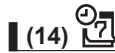

Appears when the Weekly timer is enabled.

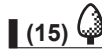

Appears while the units are operated in the energy-save mode. (Will not appear on some models of indoor units)

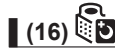

Appears while the outdoor units are operated in the silent mode.

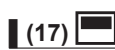

Appears when the built-in thermistor on the remote controller is activated to monitor the room temperature (11).

appears when the thermistor on the indoor unit is activated to monitor the room temperature.

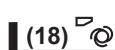

Indicates the vane setting.

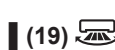

Indicates the louver setting.

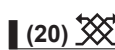

Indicates the ventilation setting.

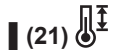

Appears when the preset temperature range is restricted.

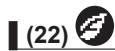

Appears when an energy-saving operation is performed using a "3D i-see Sensor" function.

(23) Centrally controlled

Appears for a certain period of time when a centrally-controlled item is operated.

(24) Preliminary error display

An error code appears during the preliminary error.

Most settings (except ON/OFF, mode, fan speed, temperature) can be made from the Main menu.

2. Parts Names

■ Wireless Remote-Controller (Optional parts)

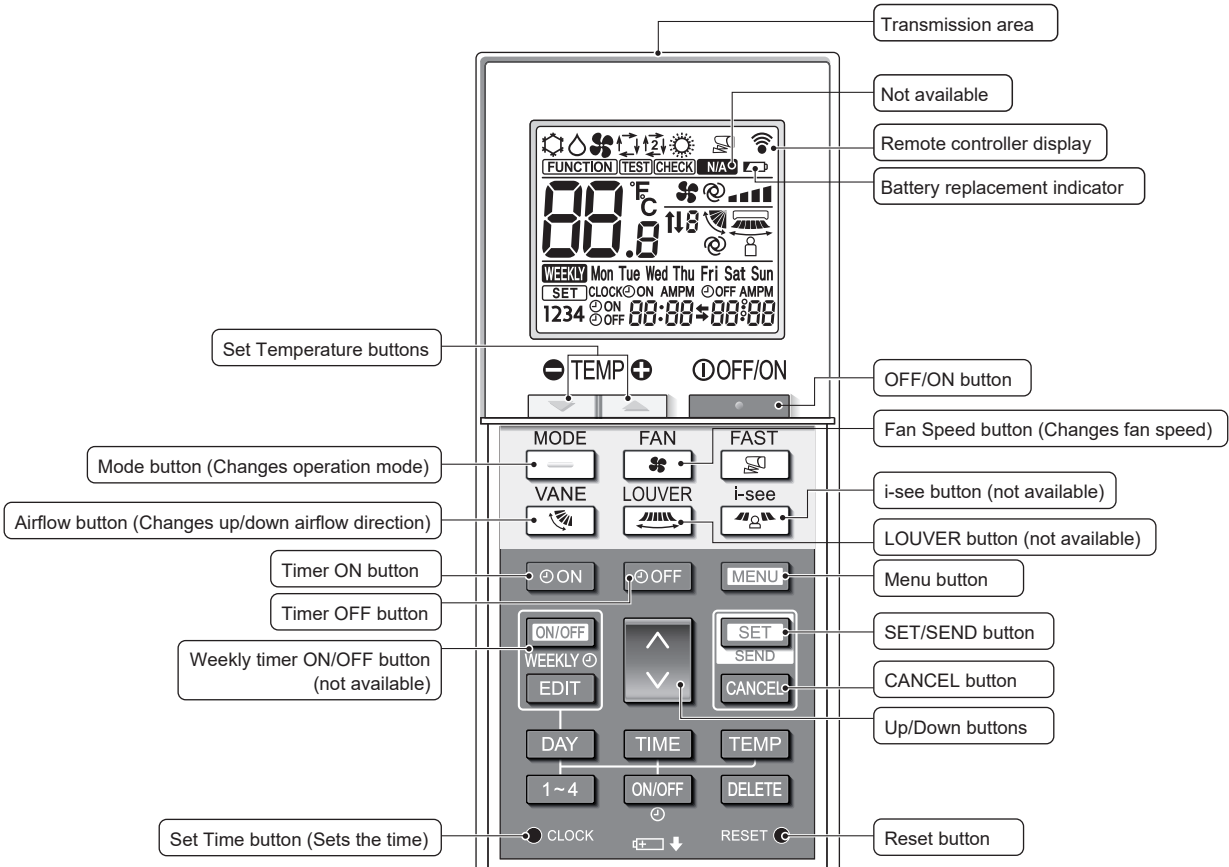

Operation mode

* The initial setting is necessary. Refer to Installation manual.

Temperature setting
The units of temperature can be changed. For details, refer to the Installation manual.

Vane setting
Step 1 Step 2 Step 3 Step 4 Step 5 Swing Auto

Not available
Appears when a non-supported function is selected.

Battery replacement indicator
Appears when the remaining battery power is low.

Fan speed setting

en

2. Parts Names

Notes (Only for wireless remote controller):

- When using the wireless remote controller, point it towards the receiver on the indoor unit.
- If the remote controller is operated within approximately 3 minutes after power is supplied to the indoor unit, the indoor unit may beep three times as the unit is performing the initial automatic check.
- The indoor unit beeps to confirm that the signal transmitted from the remote controller has been received. Signals can be received up to approximately 7 meters in a direct line from the indoor unit in an area 45° to the left and right of the unit. However, illumination such as fluorescent lights and strong light can affect the ability of the indoor unit to receive signals.
- If the operation lamp near the receiver on the indoor unit is blinking, the unit needs to be inspected. Consult your dealer for service.
- Handle the remote controller carefully! Do not drop the remote controller or subject it to strong shocks. In addition, do not get the remote controller wet or leave it in a location with high humidity.
- To avoid misplacing the remote controller, install the holder included with the remote controller on a wall and be sure to always place the remote controller in the holder after use.
- If the indoor unit beeps 4 times when you are using the wireless remote controller, switch the auto mode setting to the AUTO (single set point) mode or AUTO (dual set point) mode. For details, refer to the included Notice (A5 sheet) or the Installation Manual.

Battery installation/replacement

1. Remove the top cover, insert two LR6 AA batteries, and then install the top cover.

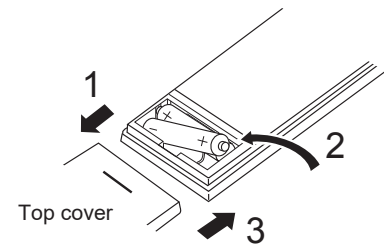

Two LR6 AA batteries
Insert the negative (-) end of each battery first. Install the batteries in the correct directions (+, -)!

2. Press the Reset button.

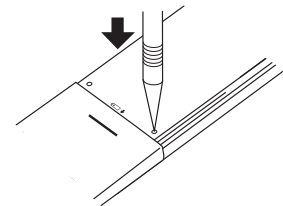

Press the Reset button with an object that has a narrow end.

After battery installation/replacement, please set the clock.
Without setting clock, you cannot use a part of function of remote controller.

3. Operation

■ About the operation method, refer to the operation manual that comes with each remote controller.

3.1. Turning ON/OFF

[ON]



Press the [ON/OFF] button.
The ON/OFF lamp will light up in green, and the operation will start.
When "LED lighting" is set to "No," the ON/OFF lamp will not light up.

[OFF]



Press the [ON/OFF] button again.
The ON/OFF lamp will come off, and the operation will stop.

Note:
Even if you press the ON/OFF button immediately after shutting down the operation is progress, the air conditioner will not start for about 3 minutes. This is to prevent the internal components from being damaged.

■ Operation at the time of restart

	Wired remote controller	Wireless remote controller
Operation mode	Operation mode before the power was turned off.	Operation mode when the wireless remote controller is turned on.
Preset temperature	Preset temperature before the power was turned off.	Preset temperature when the wireless remote controller is turned on.
Fan speed	Fan speed before the power was turned off.	Fan speed when the wireless remote controller is turned on.
Airflow direction	Airflow direction before the power was turned off.	Airflow direction when the wireless remote controller is turned on.

■ Settable preset temperature range

Operation mode	Preset temperature range
Cool/Dry	19 – 30 °C
Heat	17 – 28 °C
Auto	19 – 28 °C
Fan/Ventilation	Not settable

The settable temperature range varies with the model of outdoor units and remote controller.

en

3. Operation

3.2. Mode Selection

Each pressing of the [F1] button cycles through the following operation modes. Select the desired operation mode.

Cool Dry Fan
Auto Heat

- Operation modes that are not available to the connected outdoor unit models will not appear on the display.

What the blinking mode icon means
The mode icon will blink when other indoor units in the same refrigerant system (connected to the same outdoor unit) are already operated in a different mode. In this case, the rest of the unit in the same group can only be operated in the same mode.

3.3. Temperature setting

<Cool, Dry, Heat, and Auto (Single set point)>

Example display (Centigrade in 1-degree increments)

Press the [F2] button to decrease the preset temperature, and press the [F3] button to increase.

- Refer to the table on 3.1. for the settable temperature range for different operation modes.
- Preset temperature range cannot be set for Fan/Ventilation operation.
- Preset temperature will be displayed either in Centigrade in 0.5- or 1-degree increments, or in Fahrenheit, depending on the indoor unit model and the display mode setting on the remote controller.

Automatic operation (Single set point)

- According to a set temperature, cooling operation starts if the room temperature is too hot and heating operation starts if the room temperature is too cold.
- During automatic operation, if the room temperature changes and remains 1.5 °C or more above the set temperature for 3 minutes, the air conditioner switches to cool mode. In the same way, if the room temperature remains 1.5 °C or more below the set temperature for 3 minutes, the air conditioner switches to heat mode.

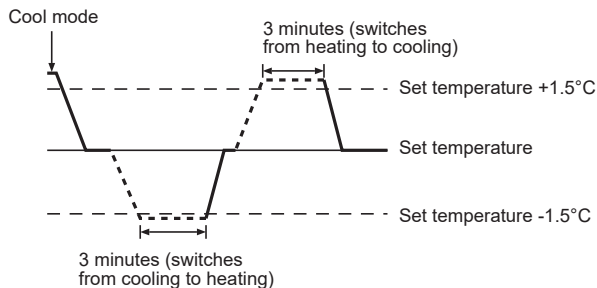

- Because the room temperature is automatically adjusted in order to maintain a fixed effective temperature, cooling operation is performed a few degrees warmer and heating operation is performed a few degrees cooler than the set room temperature once the temperature is reached (automatic energy-saving operation).

<Auto (dual set point) mode>

Preset temperature for cooling: 28.0°C

Preset temperature for heating: 20.5°C

- (1) The current preset temperatures will appear. Press the [F2] or [F3] button to display the Settings screen.

Preset temperature for cooling: 28.0°C

Preset temperature for heating: 20.5°C

Main display: Set Temp.

- (2) Press the [F1] or [F2] button to move the cursor to the desired temperature setting (cooling or heating). Press the [F3] button to decrease the selected temperature, and [F4] to increase.

- Refer to the table on 3.1. for the settable temperature range for different operation modes.
- The preset temperature settings for cooling and heating in the "Auto" (dual set point) mode are also used by the "Cool"/"Dry" and "Heat" modes.
- The preset temperatures for cooling and heating in the "Auto" (dual set point) mode must meet the conditions below:
 - Preset cooling temperature is higher than preset heating temperature.
 - The minimum temperature difference requirement between cooling and heating preset temperatures (varies with the models of indoor units connected) is met.
- * If preset temperatures are set in a way that does not meet the minimum temperature difference requirement, both preset temperatures will automatically be changed within the allowable setting ranges.

Navigating through the screens

- To return to the Main screen [RETURN] button

Automatic operation (Dual set point)

When the operation mode is set to the "Auto" (dual set point) mode, two preset temperatures (one each for cooling and heating) can be set. Depending on the room temperature, indoor unit will automatically operate in either the "Cool" or "Heat" mode and keep the room temperature within the preset range.

The graph below shows the operation pattern of indoor unit operated in the "Auto" (dual set point) mode.

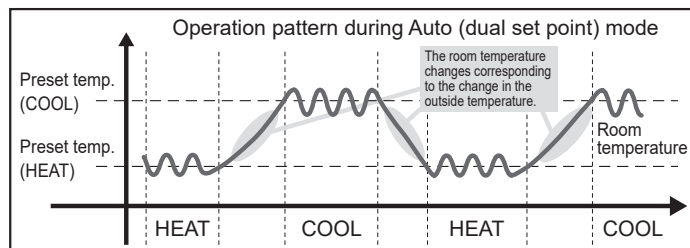

3. Operation

3.4. Fan speed setting

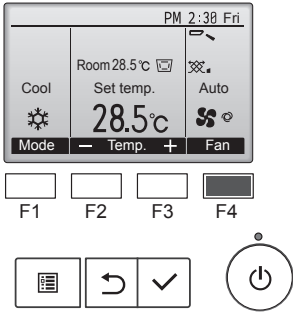

Press the [F4] button to go through the fan speeds in the following order.

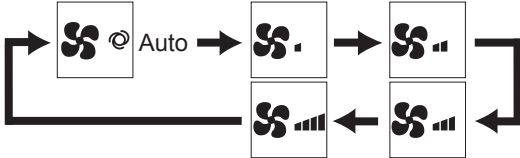

- The available fan speeds depend on the models of connected indoor units.

Note:

- The number of available fan speeds depends on the type of unit connected. Note also that some units do not provide an "Auto" setting.
- In the following cases, the actual fan speed generated by the unit will differ from the speed shown the remote controller display.
 - While the display is showing "Standby" or "Defrost".
 - When the temperature of the heat exchanger is low in the heat mode. (e.g. immediately after heat operation starts)
 - In HEAT mode, when room temperature is higher than the temperature setting.
 - In COOL mode, when room temperature is lower than the temperature setting.
 - When the unit is in DRY mode.

3.5. Airflow direction setting

3.5.1. Navigating through the Main menu

<Accessing the Main menu>

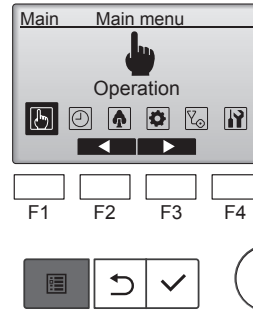

Press the [MENU] button on the Main display.
The Main menu will appear.

<Item selection>

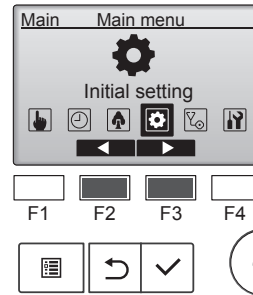

Press [F2] to move the cursor left.
Press [F3] to move the cursor right.

<Exiting the Main menu screen>

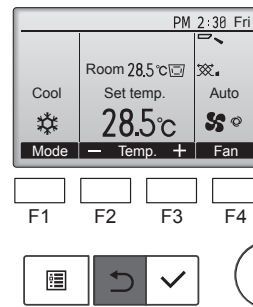

Press the [RETURN] button to exit the Main menu and return to the Main display.

If no buttons are touched for 10 minutes, the screen will automatically return to the Main display. Any settings that have not been saved will be lost.

<Display of unsupported functions>

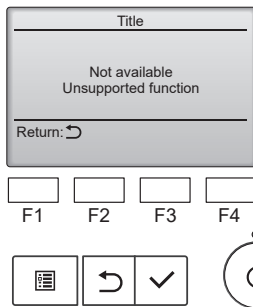

The message at left will appear if the user selects a function not supported by the corresponding indoor unit model.

en

3. Operation

3.5.2. Vane-Vent. (Lossnay)

<Accessing the menu>

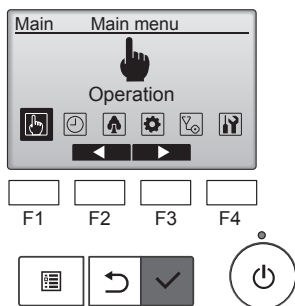

Select "Operation" from the Main menu (refer to 3.5.1.), and press the [SELECT] button.

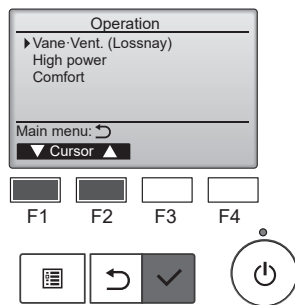

Select "Vane-Vent. (Lossnay)" or "Vane-3D i-see-Vent. (Lossnay)" from the Operation menu, and press the [SELECT] button.

Vane setting

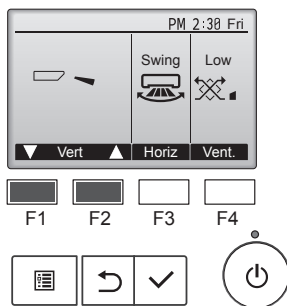

Press the button as indicated above to go through the following setting options.

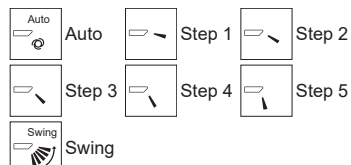

Select "Swing" to move the vanes up and down automatically. When set to "Step 1" through "Step 5", the vane will be fixed at the selected angle.

<Vent. Setting>

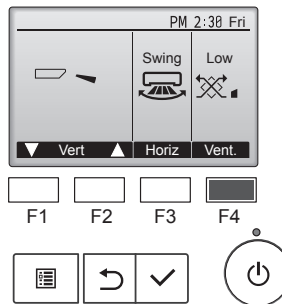

Press the [F4] button to go through the following setting options.



The fan on some models of indoor units may be interlocked with certain models of ventilation units.

<Returning to the Main menu>

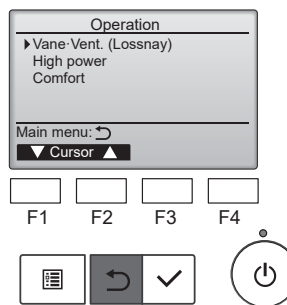

Press the [RETURN] button to go back to the Operation menu.

Notes:

- During swing operation, the directional indication on the screen does not change in sync with the directional vanes on the unit.
- Available directions depend on the type of unit connected.
- In the following cases, the actual air direction will differ from the direction indicated on the remote controller display.
 1. While the display is in "Standby" or "Defrost" states.
 2. Immediately after starting heat mode (while the system is waiting for the mode change to take effect).
 3. In heat mode, when room temperature is higher than the temperature setting.

<[Manual] To Change the Airflow's Left/Right Direction>

- * The louver button cannot be used.
 - Stop the unit operation, hold the lever of the louver, and adjust to the desired direction.
 - Do not set to the inside direction when the unit is in the cooling or drying mode because there is a risk of condensation and water dripping.



⚠ Caution:

To prevent falls, maintain a stable footing when operating the unit.

3.6. Ventilation

For LOSSNAY combination

- The following 2 patterns of operation is available.
 - Run the ventilator together with indoor unit.
 - Run the ventilator independently.

Note: (for wireless remote controller)

- Running the ventilator independently is not available.
- No indication on the remote controller.

4. Timer

4.1. For Wired Remote-controller

- Timer functions are different by each remote controller.
- For details on how to operate the remote controller, refer to the appropriate operation manual included with each remote controller.
- Weekly timer is not available with the wireless remote controller.

5. Emergency Operation for Wireless Remote-controller

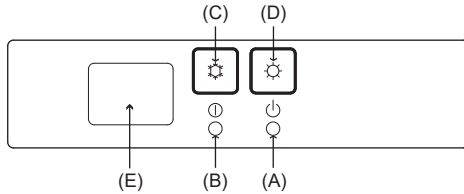

When the remote controller cannot be used

When the batteries of the remote controller run out or the remote controller malfunctions, the emergency operation can be done using the emergency buttons on the grille.

- (A) Standby lamp
- (B) Operation lamp
- (C) Emergency operation cooling switch
- (D) Emergency operation heating switch
- (E) Receiver

Starting operation

- To operate the cooling mode, press the button (C) for more than 2 seconds.
- To operate the heating mode, press the button (D) for more than 2 seconds.
- Lighting of the Operation lamp (B) means the start of operation.

Note:

- Details of emergency mode are as shown below.

Details of EMERGENCY MODE are as shown below.

Operation mode	COOL	HEAT
Set temperature	24°C	24°C
Fan speed	High	High
Airflow direction	Horizontal	Downward 5

Stopping operation

- To stop operation, press the button (C) or the button (D) for more than 2 seconds.

6. Care and Cleaning

■ Filter information

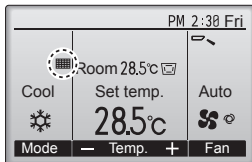

The filter sign icon will appear on the Main display in the Full mode when it is time to clean the filters.

Wash, clean, or replace the filters when this sign appears. Refer to the indoor unit Instructions Manual for details.

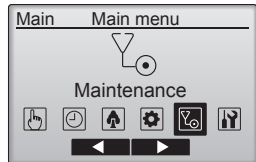

Select "Maintenance" from the Main menu, and press the [SELECT] button.

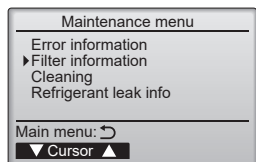

Select "Filter information" from the Maintenance menu, and press the [SELECT] button.

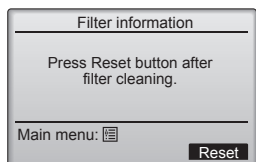

Press the [F4] button to reset filter sign.



Select "OK" with the [F4] button.

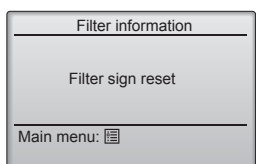
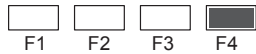

A confirmation screen will appear.

Navigating through the screens

- To go back to the Main menu [MENU] button
- To return to the previous screen [RETURN] button

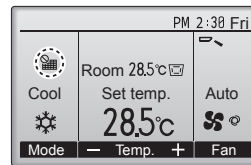

When the filter sign icon is displayed on the Main display in the Full mode, the system is centrally controlled and the filter sign cannot be reset.

If two or more indoor units are connected, filter cleaning timing for each unit may be different, depending on the filter type.

The icon will appear when the filter on the main unit is due for cleaning.

When the filter sign is reset, the cumulative operation time of all units will be reset.

The icon is scheduled to appear after a certain duration of operation, based on the premise that the indoor units are installed in a space with ordinary air quality. Depending on the air quality, the filter may require more frequent cleaning.

The cumulative time at which filter needs cleaning depends on the model.

- This indication is not available for wireless remote controller.

⚠ Caution:

- Ask authorized people to clean the filter.

▶ Cleaning the filters

- Clean the filters using a vacuum cleaner. If you do not have a vacuum cleaner, tap the filters against a solid object to knock off dirt and dust.
- If the filters are especially dirty, wash them in lukewarm water. Take care to rinse off any detergent thoroughly and allow the filters to dry completely before putting them back into the unit.

⚠ Caution:

- Do not dry the filters in direct sunlight or by using a heat source, such as an electric heater: this may warp them.
- Do not wash the filters in hot water (above 50°C), as this may warp them.
- Make sure that the air filters are always installed. Operating the unit without air filters can cause malfunction.
- Do not forcefully pull or push the vane by hand. This may cause damage.

⚠ Caution:

- Before you start cleaning, stop operation and turn OFF the power supply.
- Indoor units are equipped with filters to remove the dust of sucked-in air. Clean the filters using the methods shown in the following sketches.





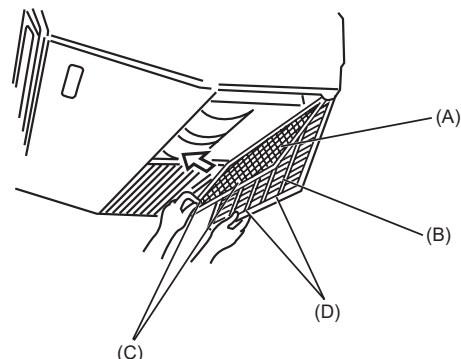

⚠ Caution:

- In removing the filter, precautions must be taken to protect your eyes from dust. Also, if you have to climb up on a stool to do the job, be careful not to fall.
- When the filter is removed, do not touch the metallic parts inside the indoor unit, otherwise injury may result.



- Open the intake grille.
 - Hold the knob on the filter then pull the filter up in the direction of an arrow. To replace the filter after cleaning, be sure to insert the filter far enough until it fits into the stopper.
- (A) Filter (B) Intake Grille (C) Knob (D) Stopper

7. Troubleshooting

Having trouble?	Here is the solution. (Unit is operating normally.)
Air conditioner does not heat or cool well.	<ul style="list-style-type: none"> ■ Clean the filter. (Airflow is reduced when the filter is dirty or clogged.) ■ Check the temperature adjustment and adjust the set temperature. ■ Make sure that there is plenty of space around the outdoor unit. Is the indoor unit air inlet or outlet blocked? ■ Has a door or window been left open?
When heating operation starts, warm air does not blow from the indoor unit soon.	<ul style="list-style-type: none"> ■ Warm air does not blow until the indoor unit has sufficiently warmed up.
During heat mode, the air conditioner stops before the set room temperature is reached.	<ul style="list-style-type: none"> ■ When the outdoor temperature is low and the humidity is high, frost may form on the outdoor unit. If this occurs, the outdoor unit performs a defrosting operation. Normal operation should begin after approximately 10 minutes.
Airflow up/down direction changes during operation or airflow up/down direction cannot be set.	<ul style="list-style-type: none"> ■ During cool mode, the vanes automatically move to the horizontal (down) position after 1 hour when the down (horizontal) airflow up/down direction is selected. This is to prevent water from forming and dripping from the vanes. ■ During heat mode, the vanes automatically move to the horizontal airflow up/down direction when the airflow temperature is low or during defrosting mode.
When the airflow up/down direction is changed, the vanes always move up and down past the set position before finally stopping at the position.	<ul style="list-style-type: none"> ■ When the airflow up/down direction is changed, the vanes move to the set position after detecting the base position.
A flowing water sound or occasional hissing sound is heard.	<ul style="list-style-type: none"> ■ These sounds can be heard when refrigerant is flowing in the air conditioner or when the refrigerant flow is changing.
A cracking or creaking sound is heard.	<ul style="list-style-type: none"> ■ These sounds can be heard when parts rub against each due to expansion and contraction from temperature changes.
The room has an unpleasant odor.	<ul style="list-style-type: none"> ■ The indoor unit draws in air that contains gases produced from the walls, carpeting, and furniture as well as odors trapped in clothing, and then blows this air back into the room.
A white mist or vapor is emitted from the indoor unit.	<ul style="list-style-type: none"> ■ If the indoor temperature and the humidity are high, this condition may occur when operation starts. ■ During defrosting mode, cool airflow may blow down and appear like a mist.
Water or vapor is emitted from the outdoor unit.	<ul style="list-style-type: none"> ■ During cool mode, water may form and drip from the cool pipes and joints. ■ During heat mode, water may form and drip from the heat exchanger. ■ During defrosting mode, water on the heat exchanger evaporates and water vapor may be emitted.
The air conditioner does not operate even though the ON/OFF button is pressed. The operation mode display on the remote controller disappears.	<ul style="list-style-type: none"> ■ Is the power switch of the indoor unit turned off? Turn on the power switch.
"  " appears in the remote controller display.	<ul style="list-style-type: none"> ■ During central control, " " appears in the remote controller display and air conditioner operation cannot be started or stopped using the remote controller.
When restarting the air conditioner soon after stopping it, it does not operate even though the ON/OFF button is pressed.	<ul style="list-style-type: none"> ■ Wait approximately 3 minutes. (Operation has stopped to protect the air conditioner.)
Air conditioner operates without the ON/OFF button being pressed.	<ul style="list-style-type: none"> ■ Is the on timer set? Press the ON/OFF button to stop operation. ■ Is the air conditioner connected to a central remote controller? Consult the concerned people who control the air conditioner. ■ Does " " appear in the remote controller display? Consult the concerned people who control the air conditioner. ■ Has the auto recovery feature from power failures been set? Press the ON/OFF button to stop operation.
Air conditioner stops without the ON/OFF button being pressed.	<ul style="list-style-type: none"> ■ Is the off timer set? Press the ON/OFF button to restart operation. ■ Is the air conditioner connected to a central remote controller? Consult the concerned people who control the air conditioner. ■ Does " " appear in the remote controller display? Consult the concerned people who control the air conditioner.
Remote controller timer operation cannot be set.	<ul style="list-style-type: none"> ■ Are timer settings invalid? If the timer can be set,  or  appears in the remote controller display.
"Please Wait" appears in the remote controller display.	<ul style="list-style-type: none"> ■ The initial settings are being performed. Wait approximately 3 minutes.
An error code appears in the remote controller display.	<ul style="list-style-type: none"> ■ The protection devices have operated to protect the air conditioner. ■ Do not attempt to repair this equipment by yourself. Turn off the power switch immediately and consult your dealer. Be sure to provide the dealer with the model name and information that appeared in the remote controller display.
Draining water or motor rotation sound is heard.	<ul style="list-style-type: none"> ■ When cooling operation stops, the drain pump operates and then stops. Wait approximately 3 minutes.

7. Troubleshooting

Having trouble?	Here is the solution. (Unit is operating normally.)												
Noise is louder than specifications.	<ul style="list-style-type: none"> ■ The indoor operation sound level is affected by the acoustics of the particular room as shown in the following table and will be higher than the noise specification, which was measured in an echo-free room. <table border="1" data-bbox="801 271 1473 450"> <thead> <tr> <th></th> <th>High sound-absorbing rooms</th> <th>Normal rooms</th> <th>Low sound-absorbing rooms</th> </tr> </thead> <tbody> <tr> <td>Location examples</td> <td>Broadcasting studio, music room, etc.</td> <td>Reception room, hotel lobby, etc.</td> <td>Office, hotel room</td> </tr> <tr> <td>Noise levels</td> <td>3 to 7 dB</td> <td>6 to 10 dB</td> <td>9 to 13 dB</td> </tr> </tbody> </table>		High sound-absorbing rooms	Normal rooms	Low sound-absorbing rooms	Location examples	Broadcasting studio, music room, etc.	Reception room, hotel lobby, etc.	Office, hotel room	Noise levels	3 to 7 dB	6 to 10 dB	9 to 13 dB
	High sound-absorbing rooms	Normal rooms	Low sound-absorbing rooms										
Location examples	Broadcasting studio, music room, etc.	Reception room, hotel lobby, etc.	Office, hotel room										
Noise levels	3 to 7 dB	6 to 10 dB	9 to 13 dB										
Nothing appears in the wireless remote controller display, the display is faint, or signals are not received by the indoor unit unless the remote controller is close.	<ul style="list-style-type: none"> ■ The batteries are low. Replace the batteries and press the Reset button. ■ If nothing appears even after the batteries are replaced, make sure that the batteries are installed in the correct directions (+, -). 												
After battery installation/replacement of remote controller, part of function cannot be used.	<ul style="list-style-type: none"> ■ Please check that the clock setting is completed. If clock setting is not done, please complete. 												
The operation lamp near the receiver for the wireless remote controller on the indoor unit is blinking.	<ul style="list-style-type: none"> ■ The self diagnosis function has operated to protect the air conditioner. ■ Do not attempt to repair this equipment by yourself. Turn off the power switch immediately and consult your dealer. Be sure to provide the dealer with the model name. 												
Warm air blows from the indoor unit intermittently when heating mode is off or during fan mode.	<ul style="list-style-type: none"> ■ When another indoor unit is operating in heating mode, the control valve opens and closes occasionally to maintain stability in the air conditioning system. This operation will stop after a while. * If this will cause an undesirable rise in the room temperature in small rooms, etc., stop the operation of the indoor unit temporarily. 												
The indoor unit which is not operating becomes warm and a sound, similar to water flowing, is heard from the unit.	<ul style="list-style-type: none"> ■ A small amount of refrigerant continues to flow into the indoor unit even though it is not operating. 												
An error code (1521, 1522, 1524, 5558) is displayed on the remote controller.	<ul style="list-style-type: none"> ■ Never repair it yourself. ■ Without turning off the breaker of the air conditioner, contact the store where you purchased the product and inform them of the product name and the content displayed on the remote controller. (If the display is 1521, 1524 or 5558*, the circulation operation will be performed. In this case, there is a risk of refrigerant leakage, so do not turn off the power breaker, ventilate the room, and return please contact.) * The circulation operation is performed when the EN 378-compliant setting is enabled and error code 5558 is displayed. 												

en

8. Specifications*

Range of application

The range of working temperatures for both the indoor and outdoor units of the series Y, R2, Multi-S is as below.

■ PCFY-MS-VKM Series

Model		MS40	MS63	MS100	MS125		
Power source (Voltage/Frequency)	<V/Hz>	~(1PHASE) 220-230-240/50, 220-230-240/60					
Capacity (Cooling/Heating) *1	<kW>	4.5/5.0	7.1/8.0	11.2/12.5	14.0/16.0		
Dimension (Height)	<mm>	230					
Dimension (Width)	<mm>	960	1280	1600			
Dimension (Depth)	<mm>	680					
Net weight	<kg>	25	32	37	39		
Fan Airflow rate (Low-Middle2-Middle1-High)	<m ³ /min>	10-11-12-13	14-15-16-18	21-24-26-28	21-24-27-31		
Noise level (Low-Middle2-Middle1-High)	<dB>	29-32-34-36	31-33-35-37	36-38-41-43	36-39-42-44		
Cooling capacity	sensible	Prated,c	<kW>	3.19	4.89	7.50	9.38
	latent	Prated,c	<kW>	1.31	2.21	3.70	4.62
Heating capacity		Prated,h	<kW>	5.00	8.00	12.50	16.00
Total electric power input		Pelec	<kW>	0.040	0.050	0.090	0.110
Sound power level (per speed setting, if applicable)		LWA	<dB>	50-53-54-57	53-55-56-58	57-59-61-63	59-61-63-65

(EU)2016/2281

Note

- * Operation temperature of indoor unit.
Cooling mode: 15 °CWB - 24 °CWB
Heating mode: 15 °CDB - 27 °CDB

- *1 Cooling/Heating capacity indicates the maximum value at operation under the following condition.
Cooling: Indoor 27 °C DB/19°C WB, Outdoor 35 °C DB
Heating: Indoor 20 °C DB, Outdoor 7 °C DB/6 °C WB

9. Maintenance

9.1. Guideline for preventive maintenance

The following maintenance intervals indicate the estimated intervals of parts replacement and repair to be required as a result of periodic inspections. They do not necessarily mean that replacement is required at the maintenance intervals.

The maintenance intervals do not indicate the warranty period.

Parts	Inspection interval	Maintenance interval*
Motor (Fan, drain pump)	1 year	20,000 hours
Bearing		15,000 hours
Electrical box		25,000 hours
Heat exchanger		5 years
Electronic expansion valve		20,000 hours
Sensor (Thermistor, refrigerant sensor, etc)		5 years
Drain pan		8 years

- The table above shows the main parts. Check the maintenance contract for details.
- This maintenance interval is an estimated period until the day when the maintenance should be conducted to use the product safely for a long time. Make use of the table above for maintenance planning (such as planning budget for maintenance inspection cost). Depending on the contents of the maintenance contract, the actual inspection and maintenance intervals may shorter than those in the table above.
- The maintenance and inspection items may differ depending on maintenance providers. Please check with your maintenance provider when concluding a maintenance contract.

* The following usage conditions are assumed.

- Normal use without frequent START/STOPS (The number of START/STOPS is assumed to be less than 6 times per hour in normal use)
- Operating hours are assumed to be 10 hours per day/2500 hours per year.

When the equipment is used under the following conditions, the maintenance interval may be shortened.

- When equipment is used in an environment where temperature and humidity are high or change dramatically
- When equipment is used in an environment where power supply fluctuations (the distortion of voltage, frequency, and waveform) are large (only within the allowable range)
- When equipment is used in an environment where the equipment may receive vibration or mechanical shock
- When equipment is used in an environment where dust, salt, toxic gases such as sulfur dioxide and hydrogen sulfide, and oil mist are present
- When equipment starts/stops frequently and operates for long periods (24-hour air-conditioning operation)

This product is designed and intended for use in the residential, commercial and light-industrial environment.

Authorised Representative in EU

Mitsubishi Electric Europe B.V.
Living Environment Systems Sales and Marketing Headquarter
2, Rue de l'Union, 92565 Rueil-Malmaison Cedex, France

Importer in European and surrounding region.

Mitsubishi Electric Europe B.V.
Capronilaan 34, 1119 NS, Schiphol Rijk, The Netherlands
https://emea.mitsubishielectric.com/en/about/local/locations/emea_europeandcis001/

French Branch
2, Rue de l'Union, 92565 Rueil-Malmaison Cedex, France
<https://fr.mitsubishielectric.com/fr/>



German Branch
Mitsubishi-Electric-Platz 1 40882 Ratingen North Rhine-Westphalia, Germany
<https://de.mitsubishielectric.com/de/>

Irish Branch
Plunkett House, Grange Castle Business Park, Nangor Road Dublin 22 Ireland
<https://ie.mitsubishielectric.com/en/>

Italian Branch
Via Energy Park 14, 20871 Vimercate (MB), Italy
<https://it.mitsubishielectric.com/it/>

Norwegian Branch
Gneisveien 2D, 1914 Ytre Enebakk, Norway
<https://no.mitsubishielectric.com/no/>

Polish Branch
Krakowska 48, PL-32-083 Balice, Poland
<https://pl.mitsubishielectric.com/pl/>

Portuguese Branch
Avda. do Forte 10, 2794-019 Carnaxide, Lisbon, Portugal
<https://pt.mitsubishielectric.com/pt/>

Scandinavian Branch
Hammarbacken 14, P.O. Box 750, SE-19127, Sollentuna, Sweden
<https://se.mitsubishielectric.com/sv/>

Spanish Branch
Av. de Castilla 2, Edificio Europa, planta primera, 28830, Pq. Empresarial San Fernando, Madrid, Spain
<https://es.mitsubishielectric.com/es/>

UK Branch
Travellers Lane, Hatfield, Hertfordshire, AL10 8XB, United Kingdom
<https://gb.mitsubishielectric.com/en/>

MITSUBISHI ELECTRIC TURKEY ELEKTRİK ÜRÜNLERİ A.Ş.
Şerifali Mahallesi Kale Sokak No: 41, 34775 Ümraniye, İstanbul, Türkiye
<https://tr.mitsubishielectric.com/tr/>

Please be sure to put the contact address/telephone number on
this manual before handing it to the customer.
Lütfen bu kılavuzu müşteriye teslim etmeden önce iletişim adresini/telefon
numarasını eklemeyi unutmayın.

MITSUBISHI ELECTRIC CORPORATION
HEAD OFFICE: TOKYO BUILDING, 2-7-3, MARUNOUCHI, CHIYODA-KU, TOKYO 100-8310, JAPAN