



ecodan

Cylinder unit

EHPT20X-MEHEW

INSTALLATION MANUAL

FOR INSTALLER

English

Contents

For safe and correct use, read this manual and the outdoor unit installation manual thoroughly before installing the cylinder unit. English is the original language. The other language versions are translations of the original.

- 1. Safety Notices..... 2
- 2. Introduction..... 3
- 3. Technical Information 4
- 4. Installation..... 9
 - 4.1 Location 9
 - 4.2 Water Quality and System Preparation..... 10
 - 4.3 Water Pipe Work..... 11
 - 4.4 Safety Device Discharge Arrangements (G3) 15
 - 4.5 Electrical Connection 16
- 5. System Set Up 18
 - 5.1 DIP Switch Functions 18
 - 5.2 Connecting inputs/outputs 19
 - 5.3 Wiring for 2-zone temperature control 22
 - 5.4 Indoor unit only operation (during installation work) 24
 - 5.5 Smart grid ready 24
 - 5.6 Forced cooling mode input (IN13)..... 24
 - 5.7 Using microSD memory card..... 25
- 6. Remote Controller 26
- 7. Commissioning..... 33
- 8. Service and Maintenance..... 34





<https://www12.mitsubishielectric.com/>

Should you need more information, please access above website to download detailed manuals, select your region, select model name, then choose your language.

Contents of website manual

- Energy monitor
- Component parts (detail)
- Water circuit diagram
- Room thermostat
- Filling the system
- Simple 2-zone system
- Independent electrical power source
- Smart grid ready
- Remote controller options
- Service menu (special setting)
- Supplementary information

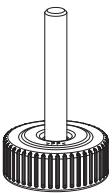
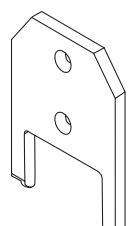
en

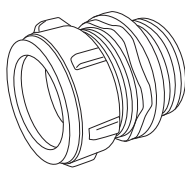
Accessories (Included)			
Adjustable feet	Immersion heater boss tool	Gasket	G1 Joint
 4	EHPT20X-MEHEW model only  1	 G3/4 G1 6 *1	E*PT series only (for return to heat pump connection (28mm) and flow from heat pump connection (28mm))  2

*1 Gasket for Heating Flow/Return (G1): 2pcs
 Gasket for G1 Joint (G1): 2pcs
 Gasket for DHW Inlet/Outlet (G3/4): 2pcs

Abbreviations and glossary

No.	Abbreviations/Word	Description
1	Weather compensation curve mode	Space heating/cooling incorporating outdoor ambient temperature compensation
2	Cylinder unit	Indoor unvented DHW tank and component plumbing parts
3	DHW mode	Domestic Hot Water heating mode for showers, sinks, etc
4	Flow temperature	Temperature at which water is delivered to the primary circuit
5	Freeze stat. function	Heating control routine to prevent water pipes freezing
6	FTC	Flow Temperature Controller, the circuit board in charge of controlling the system
7	Heating mode	Space heating through radiators or underfloor heating
8	Legionella	Bacteria potentially found in plumbing, showers and water tanks that may cause Legionnaires disease
9	LP mode	Legionella prevention mode – a function on systems with water tanks to prevent the growth of legionella bacteria
10	Packaged model	Plate heat exchanger (Refrigerant - Water) in the outdoor heat pump unit
11	PRV	Pressure Relief Valve
12	Return temperature	Temperature at which water is delivered from the primary circuit
13	Split model	Plate heat exchanger (Refrigerant - Water) in the indoor unit
14	TRV	Thermostatic Radiator Valve – a valve on the entrance or exit of the radiator panel to control the heat output
15	Cooling mode	Space cooling through fan-coils or underfloor cooling

1 Safety Notices

Please read the following safety precautions carefully.





⚠ WARNING:
Precautions that must be observed to prevent injuries or death.

⚠ CAUTION:
Precautions that must be observed to prevent damage to unit.

This installation manual along with the operation manual should be left with the product after installation for future reference. Mitsubishi Electric is not responsible for the failure of locally-supplied parts.

- Be sure to perform periodical maintenance.
- Be sure to follow your local regulations.
- Be sure to follow the instructions provided in this manual.

MEANINGS OF SYMBOLS DISPLAYED ON THE UNIT

	WARNING (Risk of fire)	This mark is for R32 refrigerant only. Refrigerant type is written on the nameplate of outdoor unit. In case that refrigerant type is R32, this unit uses a flammable refrigerant. If refrigerant leaks and comes in contact with fire or heating part, it will create harmful gas and there is risk of fire.
		Read the OPERATION MANUAL carefully before operation.
		Service personnel are required to carefully read the OPERATION MANUAL and INSTALLATION MANUAL before operation.
		Further information is available in the OPERATION MANUAL, INSTALLATION MANUAL, and the likes.

en

⚠ ⚠ WARNING

Mechanical

- The cylinder unit and outdoor unit must not be installed, disassembled, relocated, altered or repaired by the user. Ask an authorised installer or technician. If the unit is installed improperly or modified after installation, water leakage, electric shock or fire may result.
- The outdoor unit should be securely fixed to a hard level surface capable of bearing its weight.
- The cylinder unit should be positioned on a hard level surface capable of supporting its filled weight to prevent excessive sound or vibration.
- Do not position furniture or electrical appliances below or above the outdoor unit or cylinder unit.
- Safety relief valve connections must NOT be used for any other purpose.
- For UK model, NO valve should be fitted between the expansion valve and the storage cylinder.
- Only use accessories and replacement parts authorised by Mitsubishi Electric. Ask a qualified technician to fit the parts.

Electrical

- All electrical work should be performed by a qualified technician according to local regulations and the instructions given in this manual.
- The units must be powered by a dedicated power supply and the correct voltage and circuit breakers must be used.
- Wiring should be in accordance with national wiring regulations. Connections must be made securely and without tension on the terminals.
- Earth unit correctly.

General

- Keep children and pets away from both the cylinder unit and outdoor unit.
- Do not use the hot water produced by the heat pump directly for drinking or cooking. This could cause illness to the user.
- Do not stand on the units.
- Do not touch switches with wet hands.
- Annual maintenance checks on both the cylinder unit and the outdoor unit should be conducted by a qualified person.
- Do not place containers with liquids on top of the cylinder unit. If they leak or spill onto the cylinder unit, damage to the unit and/or fire could occur.
- Do not place any heavy items on top of the cylinder unit.
- When installing, relocating, or servicing the cylinder unit, use only the heat pump's specified refrigerant to charge the refrigerant lines. Do not mix it with any other refrigerant and do not allow air to remain in the lines. If air is mixed with the refrigerant, then it can be the cause of abnormal high pressure in the refrigerant line, and may result in an explosion and other hazards.
- The use of any refrigerant other than that specified for the system will cause mechanical failure or system malfunction or unit breakdown. In the worst case, this could lead to a serious impediment to securing product safety.
- In heating mode, to avoid the heat emitters being damaged by excessively hot water, set the target flow temperature to a minimum of 2°C below the maximum allowable temperature of all the heat emitters. For Zone 2, set the target flow temperature to a minimum of 5°C below the maximum allowable flow temperature of all the heat emitters.
- Do not install the unit where combustible gas may leak, be produced, flow, or accumulate. If combustible gas accumulates around the unit, fire or explosion may result.
- Do not use means to accelerate the defrosting process or to clean, other than those recommended by the manufacturer.
- The appliance shall be stored in a room without continuously operating ignition sources (for example: open flames, an operating gas appliance or an operating electric heater).
- Do not pierce or burn.
- Be aware that refrigerants may not contain an odour.
- Pipe-work shall be protected from physical damage.
- The installation of pipe-work shall be kept to a minimum.
- Compliance with national gas regulations shall be observed.
- Keep any required ventilation openings clear of obstruction.
- Do not use low temperature solder alloy in case of brazing the refrigerant pipes.
- Refrigerant leakage may cause suffocation. Provide ventilation in accordance with EN378-1.
- Be sure to wrap insulation around the piping. Direct contact with the bare piping may result in burns or frostbite.

1 Safety Notices

⚠ CAUTION

Use clean water that meets local quality standards on the primary circuit.

The outdoor unit should be installed in an area with sufficient airflow according to the diagrams in the outdoor unit installation manual.

The cylinder unit should be located inside to minimise heat loss.

Water pipe-runs on the primary circuit between outdoor and indoor unit should be kept to a minimum to reduce heat loss.

Ensure condensate from outdoor unit is piped away from the base to avoid puddles of water.

Remove as much air as possible from the primary and DHW circuits.

Never put batteries in your mouth for any reason to avoid accidental ingestion.

Battery ingestion may cause choking and/or poisoning.

Do not transport the cylinder unit with water inside the DHW tank. This could cause damage to the unit.

If power to the cylinder unit is to be turned off (or system switched off) for a long time, the water of DHW tank should be drained.

Do not drain the water in the primary circuit and do not turn off the power.

If unused for a long period, before operation is resumed, DHW tank should be properly sterilised or flushed through with potable water and complete a Legionella prevention cycle.

Preventative measures should be taken against water hammer, such as installing a Water Hammer Arrestor on the primary water circuit, as directed by the manufacturer.

Water draining from the tank is hot and it may cause burns.

As for the handling of refrigerant, refer to the outdoor unit installation manual.

en

2 Introduction

The purpose of this installation manual is to instruct competent persons how to safely and efficiently install and commission the cylinder unit system. The target readers of this manual are competent plumbers and/or refrigeration engineers who have attended and passed the requisite Mitsubishi Electric product training and have appropriate qualifications for installation of an unvented hot water cylinder unit specific to their country.

3 Technical Information

Product specification

Model name		EHPT20X-MEHEW		
Nominal domestic hot water volume		200 L		
Overall unit dimensions (Height × Width × Depth)		1600 × 595 × 680 mm		
Water volume of heating circuit in the unit *1		3.7 L		
Unvented expansion vessel (Primary heating)	Nominal volume	-		
	Charge pressure	-		
Safety device	Primary circuit	Control thermistor	80 °C	
		Pressure relief valve	0.3 MPa (3 bar)	
		Flow sensor	Min. flow 5.0 L/min (See table 4.3.1 about water flow rate range)	
	Booster heater	BH manual reset thermostat	-	
		BH thermal cut-out	-	
	DHW tank	Control thermistor	75 °C	
		IH manual reset thermostat	85 °C	
		Temperature/ Pressure relief valve	90°C /	
			0.7 MPa (7 bar)	
Connections	Water	Primary circuit	G1	
		DHW circuit	G3/4	
	Refrigerant (R32/ R410A)	Liquid	-	
		Gas	-	
Operating range	Heating	Room temperature	10 - 30 °C	
		Flow temperature *6, *7	20 - 75 °C	
	Cooling	Room temperature	-	
		Flow temperature	-	
	DHW		40 - 70 °C	
	Legionella prevention		60 - 70 °C	
Guaranteed operating range *2	Ambient		0 - 35 °C (≤ 80 %RH)	
	Outdoor temperature	Heating	See outdoor unit spec table.	
		Cooling	-	
Electrical data	Control board (Including 4 pumps)	Power supply (Phase, voltage, frequency)	~N, 230 V, 50 Hz	
		Input	0.30 kW	
		Current	1.95 A	
		Breaker	10 A	
	Booster heater	Power supply (Phase, voltage, frequency)	-	
		Capacity	-	
		Current	-	
		Breaker	-	
	Immersion heater *5	Power supply (Phase, voltage, frequency)	~N, 230 V, 50 Hz	
		Capacity	3 kW	
		Current	13 A	
		Breaker	16 A	
Sound power level (PWL)		40 dB (A)		

<Table 3.1>

*1 This value does not contain: the volume of sanitary circuit, primary DHW circuit (from 3-way valve to confluent point with heating circuit), piping to expansion vessel, and expansion vessel.

*2 The environment must be frost-free.

*3 See outdoor unit spec table (min, 10°C). Cooling mode is not available in low outdoor temperature.

If you use our system in cooling mode at the low ambient temperature (10°C or below), there are some risks of plate heat exchanger damages by frozen water.

*4 For the model without booster heater and immersion heater, the maximum allowable hot water temperature is "Maximum outlet water of outdoor unit -3°C".

For the maximum outlet water of outdoor unit, refer to outdoor unit Data Book.

*5 Do not fit immersion heaters without thermal cut-out. Use only Mitsubishi Electric service parts as a direct replacement.

*6 Maximum temperature of E****F model depending on the connected outdoor unit. PUZ: 70°C, Others: 60°C

*7 Maximum temperature of E****X model depending on the connected outdoor unit. WZ: 75°C, Others: 60°C

3 Technical Information

■ Technical Drawings <EHPT20X-MEHEW> (Packaged model system)

<Unit: mm>

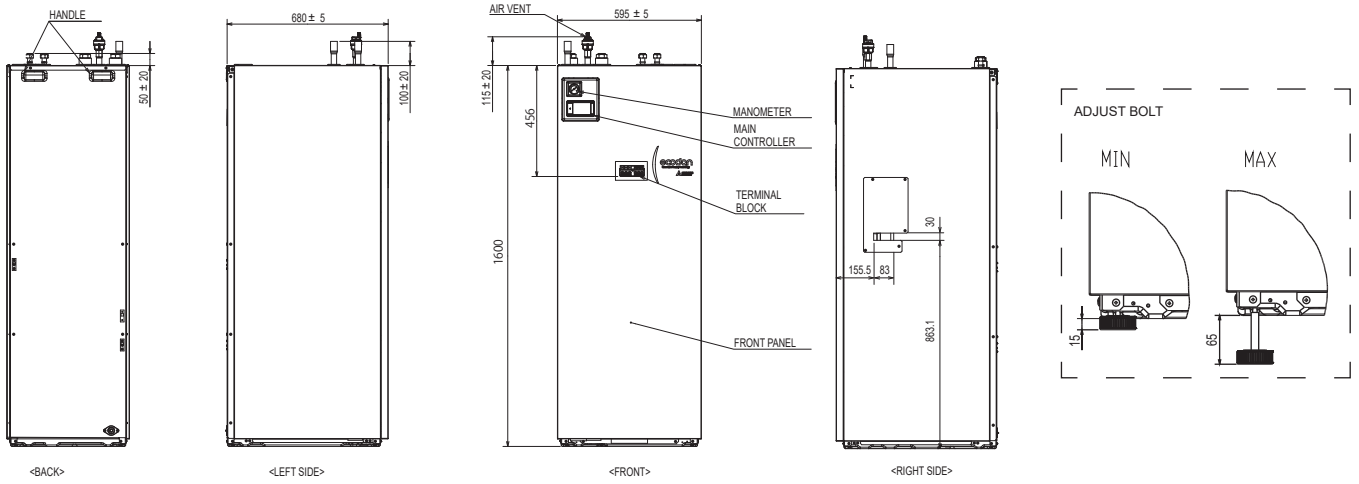
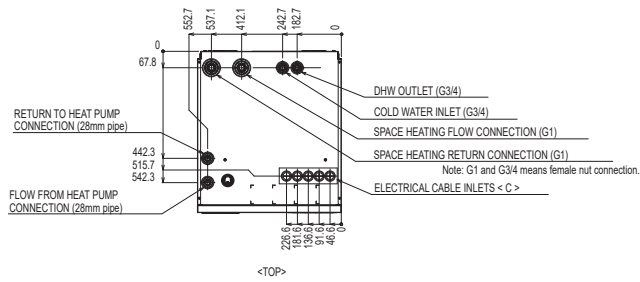

Pipe description	Connection size/type
Electrical cable inlets 	For inlets ①, ② and ③, run low-voltage wires including external input wires and thermistor wires. For inlets ④ and ⑤, run high-voltage wires including power cable, indoor-outdoor cable, and external output wires. Note: For a wireless receiver (option) cable and ecodan Wi-Fi interface (option) cable, use inlet ①.

<Table 3.2>

3 Technical Information

■ Component Parts

<EHPT20X-MEHEW> (Packaged model system)

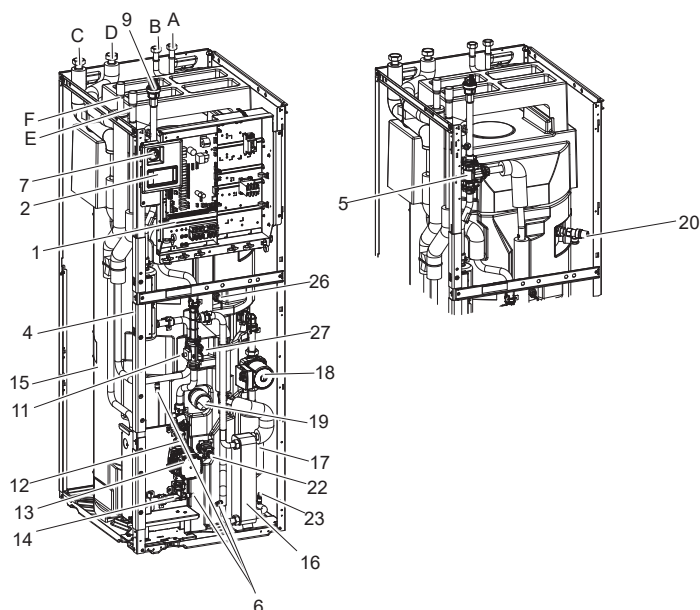

<Figure 3.1>

Note:

For installation of EHPT20X-MEHEW model, make sure to install a suitably sized primary-side expansion vessel. (See figure 3.2 for further guidance)

No.	Part name	No.	Part name	No.	Part name
A	DHW outlet pipe	14	Pump Elbow	35	Magnetic filter (Local supply) (Recommended)
B	Cold water inlet pipe	15	DHW tank	36	Strainer (Local supply)
C	Water pipe (Space heating/cooling return connection)	16	Plate heat exchanger (Water - Water)	37	Pressure relief valve (3 bar - In outdoor unit)
D	Water pipe (Space heating/cooling flow connection)	17	Scale trap	38	Inlet control group *2
E	Water pipe (Flow from heat pump connection)	18	Water circulation pump (Sanitary circuit)	39	Filling loop (Ball valves, check valves and flexible hose) *2
F	Water pipe (Return to heat pump connection)	19	Immersion heater *1	40	Sanitary expansion vessel *2
G	Refrigerant pipe (Gas)	20	Temperature and pressure relief valve *1	41	Air vent (Local supply)
H	Refrigerant pipe (Liquid)	21	Pressure relief valve (10 bar) (DHW Tank) (Local supply)	42	Pressure relief valve (5 bar) *6
1	Control and electrical box	22	Drain cock (DHW tank)	43	Water circulation pump 2 (Zone 1) (Local supply)
2	Main remote controller	23	Drain cock (Sanitary circuit)	44	Water circulation pump 3 (Zone 2) (Local supply)
3	Plate heat exchanger (Refrigerant - Water)	24	Thermistor (Flow water temp.) (THW1)	45	Mixing valve (Local supply)
4	Booster heater 1, 2	25	Thermistor (Return water temp.) (THW2)	46	Magnetic filter (Local supply) *5
5	3-way valve	26	Thermistor (DHW tank upper water temp.) (THW5A)	47	Mud trap (Local supply)
6	Drain cock (Primary circuit)	27	Thermistor (DHW tank lower water temp.) (THW5B)	48	Thermistor (Zone 1 flow water temp.) (THW6)
7	Manometer	28	Thermistor (Ref. liquid temp.) (TH2)	49	Thermistor (Zone 1 return water temp.) (THW7)
8	Pressure relief valve (3 bar) *3	29	Pressure sensor (Local supply)	50	Thermistor (Zone 2 flow water temp.) (THW8)
9	Automatic air vent	30	Drain pan *3	51	Thermistor (Zone 2 return water temp.) (THW9)
10	Expansion vessel (Primary circuit) (Local supply)	31	Outdoor unit	52	Header
11	Flow sensor	32	Drain pipe (Local supply)		
12	Magnetic filter	33	Back flow prevention device *4		
13	Water circulation pump 1 (Primary circuit)	34	Isolating valve (Local supply)		

<Table 3.3>

*1 Factory-fitted with UK model ONLY.

*2 Please refer to PAC-WK02UK-E Installation Manual for more information on accessories.

*3 EHPT20X-MEHEW NOT available.

*4 For UK, this is part of ICG.

*5 Factory-fitted with ERST17D-***BE ONLY.

*6 ONLY E***T***-M***E* model.

Model name	EHPT20X-MEHEW
Maximum supply pressure to the pressure reducing valve	16 bar
Operating pressure (Sanitary side)	3.5 bar
Expansion vessel charge setting pressure (Sanitary side)	3.5 bar
Expansion valve setting pressure (Sanitary side)	6.0 bar
Immersion heater specification (Sanitary side) *	3000 W, 230 V
DHW tank capacity	200 L
Mass of the unit when full	287 kg
Maximum primary working pressure	2.5 bar
Maximum sanitary-side working pressure	5.5 bar

<Table 3.4>

3 Technical Information

Water circuit diagram

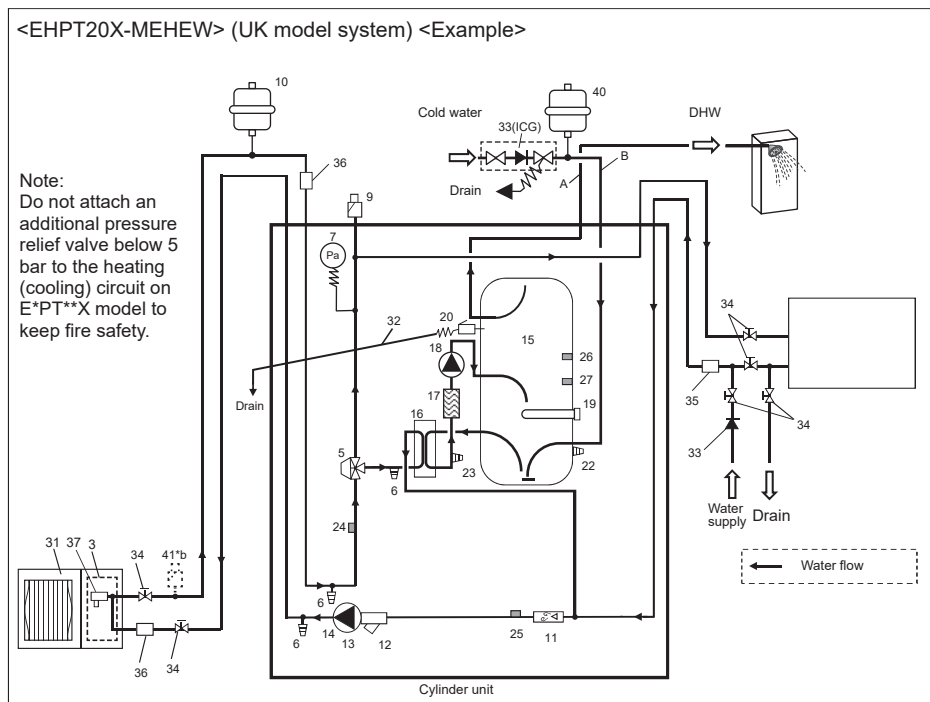

<Figure 3.2>

Go to the Mitsubishi Electric website to check the water circuit of other units and the component parts of each unit.

*a Refer to the following section "Local system".

*b If the outdoor unit is higher than the indoor unit, or if there is a location where air gets trapped in the upper part of the water pipe, consider adding this part.

Notes

- To enable draining of the cylinder unit, an isolating valve should be positioned on both the inlet and outlet pipework.
- Be sure to install a strainers on the inlet and outlet pipework (item 36) to the cylinder unit.
- Suitable drain pipework should be attached to the relief valves instructed to be connected to it in Figures 3.2 in accordance with your country's regulations.
- A backflow prevention device must be installed on the cold water supply pipework (IEC 61770)
- When using components made from different metals or connecting pipes made of different metals, insulate the joints to prevent any corrosive reaction taking place which may damage the pipework.
- Be sure to install a magnetic filter (item 35) on the space heating return to the cylinder unit.
- For UK model, be sure to appropriately install primary expansion vessel item 10 (Local supply).

Local system

1-zone temperature control

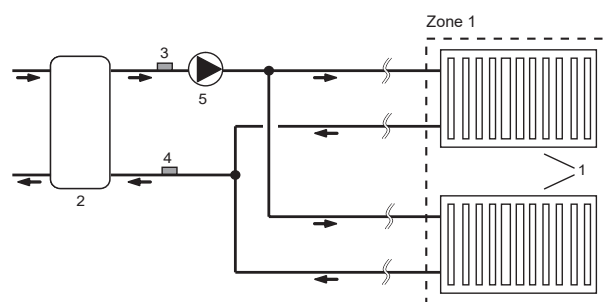
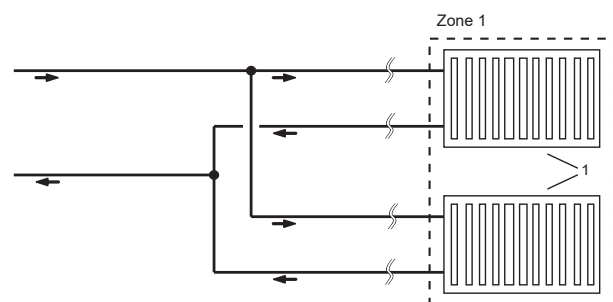

2-zone temperature control

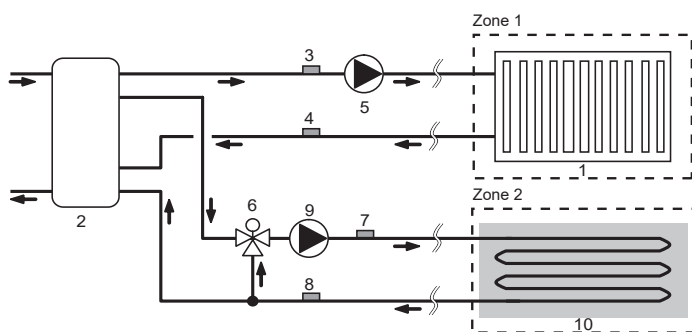

1-zone temperature control with boiler

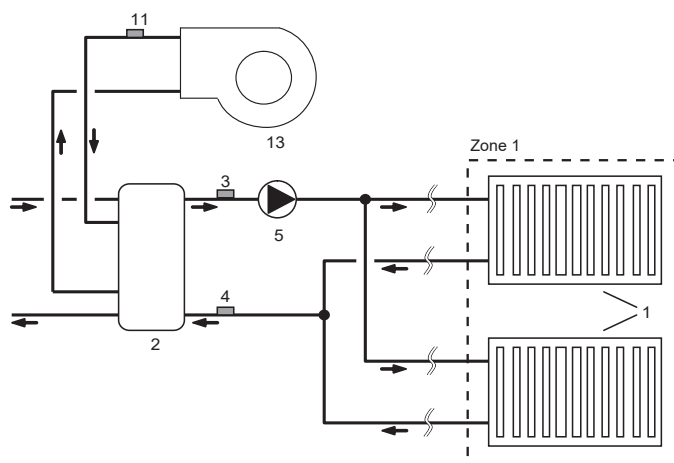

2-zone temperature control & Buffer tank control

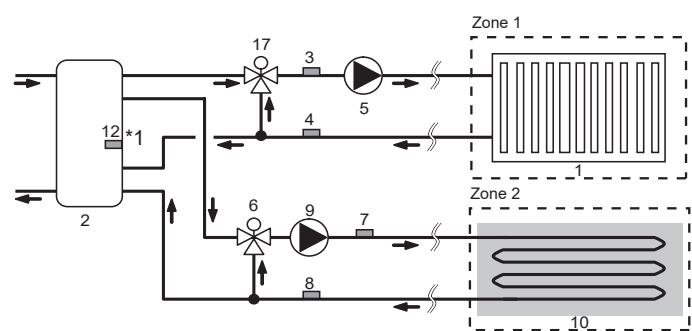

1-zone temperature control (2-zone valve ON/OFF control)

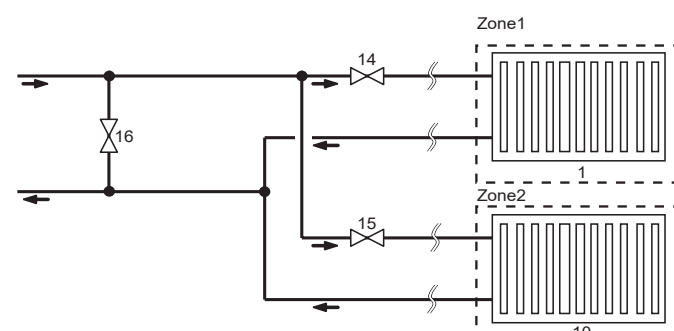

- 1. Zone 1 heat emitters (e.g. radiator, fan coil unit) (local supply)
- 2. Mixing tank (local supply)
- 3. Thermistor (Zone 1 flow water temp.) (THW6)
- 4. Thermistor (Zone 1 return water temp.) (THW7) } Optional part : PAC-TH011-E
- 5. Zone 1 water circulation pump (local supply)
- 6. Zone 2 motorized mixing valve (local supply)
- 7. Thermistor (Zone 2 flow water temp.) (THW8)
- 8. Thermistor (Zone 2 return water temp.) (THW9) } Optional part : PAC-TH011-E
- 9. Zone 2 water circulation pump (local supply)

- 10. Zone 2 heat emitters (e.g. underfloor heating) (local supply)
- 11. Thermistor (Boiler flow water temp.) (THWB1)
- 12. Thermistor (Mixing tank water temp.) (THW10) *1 } Optional part : PAC-TH012HT(L)-E
- 13. Boiler (local supply)
- 14. Zone 1 2-way valve (local supply)
- 15. Zone 2 2-way valve (local supply)
- 16. Bypass valve (local supply)
- 17. Zone 1 motorized mixing valve (local supply)

*1 ONLY buffer tank control (heating/cooling) applies to "Smart grid ready".

4 Installation

<Preparation before the installation and service>

- Prepare the proper tools.
- Prepare the proper protection.
- Allow parts to cool before attempting any maintenance.
- Provide adequate ventilation.
- After stopping the operation of the system, turn off the power-supply breaker and remove the power plug.
- Discharge the capacitor before commencing work involving the electric parts.

<Precautions during service>

- Do not perform work involving electric parts with wet hands.
- Do not pour water or liquid into the electric parts.
- Do not touch the refrigerant.
- Do not touch the hot or cold surfaces in the refrigerant cycle.
- When the repair or the inspection of the circuit needs to be carried out without turning off the power, exercise great caution NOT to touch any LIVE parts.

4.1 Location

■ Transportation and Handling

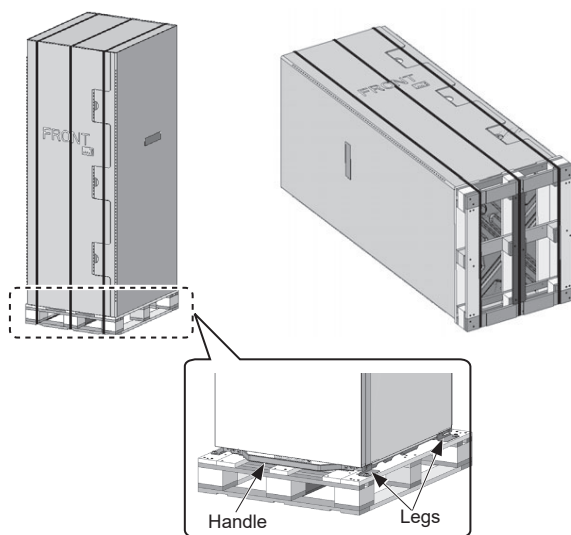

<Figure 4.1.1>

Cylinder unit is delivered on a wooden pallet base with cardboard protection.

Care should be taken when transporting the cylinder unit that the casing is not damaged by impact. Do not remove the protective packaging until cylinder unit has reached its final location. This will help protect the structure and control panel.

- The cylinder unit can be transported either vertically or horizontally. If transported horizontally, the panel marked 'Front' must be facing **UPWARDS** <Figure 4.1.1>.
- The cylinder unit should **ALWAYS** be moved by a minimum of 3 people.
- When carrying the cylinder unit, use the handles provided.
- Before using the handles, make sure they are securely attached.
- **Please wear protective equipment when you touch front handle.** It could cause injury if you do not wear the protective equipment.
- **Please remove front handle, fixing legs, wooden base and any other packaging once the unit is in installation location.**
- **Keep the handles for future transportation.**

■ Suitable Location

Before installation, the cylinder unit should be stored in a frost-free weather-proof location. Units must **NOT** be stacked.

- The cylinder unit should be installed indoors in a frost free weather proof location.
- Install the cylinder unit where it is not exposed to water/excessive moisture.
- The cylinder unit should be positioned on a level surface capable of supporting it's **FILLED** weight. (Adjustable feet (accessory parts) can be used to ensure unit is level.)
- When using the adjustable feet, ensure that the floor is strong enough.
- Care should be taken that minimum distances around and in front of the unit for service access are observed <Figure 4.1.2>.
- Secure the cylinder unit to prevent it being knocked over.
- Please be careful not to break the insulation attached to the unit.

■ Service access diagrams

Service access	
Parameter	Dimension (mm)
a	300*
b	150
c	10
(distance behind unit not visible in Figure 4.1.2)	
d	500

<Table 4.1.1>

Sufficient space **MUST** be left for the provision of discharge pipework as detailed in National and Local Building Regulations.

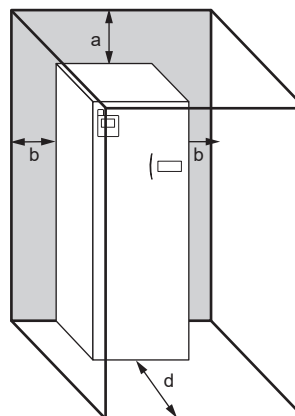

<Figure 4.1.2>

Service access

* An additional 300 mm of space (total 600 mm) is required, when installing the optional 2-zone kit (PAC-TZ02-E2) on top of the cylinder unit.

The cylinder unit must be located indoors and in a frost-free environment, for example in a utility room, to minimise heat loss from stored water.

■ Repositioning

If you need to move the cylinder unit to a new position, fully drain the cylinder unit before moving to avoid damage to the unit.

4 Installation

4.2 Water Quality and System Preparation

The water quality must comply with European Directive (EU) 2020/2184 standards, and/or local national standards.

For example, in France : Arrêté du 11 Janvier 2007 relative aux limites et références de qualité des eaux brutes et des eaux destinées à la consommation humaine

■ Water quality in primary circuit

- The water in primary circuit should observe local national standards :
For example, in Germany and Belgium : VDI2035 Sheet 1
- The water in primary circuit should be clean and with a pH value of pH6.5-10.0.

■ Water quality in sanitary circuit

- The sanitary water circuit should be clean and with a pH value of pH6.5-8.0
- The following are maximum values of water in sanitary circuit;
Calcium: 100 mg/L, Hardness: 250 mg/L (Ca Hardness)
14.0 °dH (German degree)
25 °f (French degree)
17.5 °E (English degree)
Chloride: 100 mg/L, Copper: 0.3 mg/L
- Other constituents of water in sanitary circuit should be compliant with European Directive (EU) 2020/2184 standards.
- In known hard water areas, to prevent/minimise scaling, it is beneficial to restrict the routine stored water temperature (DHW maximum temperature) to 55°C, and/or to add an appropriate water treatment (i.e: softener).

■ Anti-Freeze

Anti-freeze solutions should use propylene glycol with a toxicity rating of Class 1 as listed in Clinical Toxicology of Commercial Products, 5th Edition.

Notes:

- Ethylene glycol is toxic and should NOT be used in the primary water circuit in case of any cross-contamination of the potable circuit.
- For 2-zone valve ON/OFF control, propylene glycol should be used.

■ New Installation (primary water circuit)

- Before connecting outdoor unit, thoroughly cleanse pipework of building debris, solder, etc. using a suitable chemical cleansing agent.
- Flush the system to remove chemical cleanser.
- For all packaged model systems, add a combined inhibitor and anti-freeze solution to prevent damage to the pipework and system components.
- For split model systems, the responsible installer should decide if anti-freeze solution is necessary for each site's conditions. Corrosion inhibitor however should ALWAYS be used.

■ Existing Installation (primary water circuit)

- Before connecting outdoor unit, the existing heating circuit MUST be chemically cleansed to remove existing debris from the heating circuit.
- Flush the system to remove chemical cleanser.
- For all packaged model systems, and the split model or PUMY system without booster heater, add a combined inhibitor and anti-freeze solution to prevent damage to the pipework and system components.
- For split model systems, the responsible installer should decide if anti-freeze solution is necessary for each site's conditions. Corrosion inhibitor however should ALWAYS be used.

When using chemical cleansers and inhibitors, always follow manufacturer's instructions and ensure the product is appropriate for the materials used in the water circuit

■ Minimum amount of water required in the space heating/cooling circuit

Outdoor heat pump unit		Indoor unit containing water amount [L]	Additional required water amount [L]*1	
			Average / Warmer climate*2	Colder climate*2
Packaged model	PUZ-WZ50	5	2	24
	PUZ-WZ60		4	21
	PUZ-WZ80		6	29
Split model SUZ series	SUZ-SWM40VA	5	1	12
	SUZ-SWM60VA		2	21
	SUZ-SWM80VA		4	29
	SUZ-SWM30VA		5 *3	12 *3
	SUZ-SWM40VA2		5 *3	12 *3
	SUZ-SWM60VA2		9 *3	21 *3
	SUZ-SWM80VA(H)2		12 *3	29 *3
	SUZ-SWM100VA(H)		12 *3	38 *3
	SUZ-SHWM30VAH		9 *3	21 *3
	SUZ-SHWM40VAH		9 *3	21 *3
	SUZ-SHWM60VAH		12 *3	29 *3
Split model PUZ series	PUZ-S(H)WM60	5	4	21
	PUZ-S(H)WM80		6	29
	PUZ-S(H)WM100		9	38
	PUZ-S(H)WM120		12	47
	PUZ-S(H)WM140		15	55
Split model Multi series	PUMY-P112	5	22	75
	PUMY-P125		22	75
	PUMY-P140		22	75
	PXZ-4F75VG		6	27
	PXZ-5F85VG		6	29

<Table 4.2.1>

*1 Water amount: If there is a bypass circuit, above table means minimum water amount in case of bypass.

*2 Climate: Please refer to 2009/125/EC: Energy-related Products Directive and Regulation (EU) No 813/2013 to confirm your climate zone.

*3 SUZ series: Flow temperature MUST always be NO lower than 32 °C when outdoor temperature drops below -15 °C. Potential risks of plate HEX get frozen and damaged, and also outdoor HEX would be frosted due to insufficient defrosting.

Case 1. No division between primary and secondary circuit

- Please ensure the required water amount according to Table 4.2.1 by water pipe and radiator or underfloor heating.

Case 2. Separate primary and secondary circuit

- If the interlock operation of primary and secondary pump is not available, please ensure required additional water in only primary circuit according to Table 4.2.1.
- If the interlock operation of primary and secondary pump is available, please ensure total water amount of primary and secondary circuit according to Table 4.2.1.

In case of the shortage of required water amount, please install buffer tank.

4 Installation

4.3 Water Pipe Work

■ Hot Water Pipework

The cylinder unit is **UNVENTED**. When installing unvented hot water systems, building regulations part G3 (England and Wales), P3 (Scotland) and P5 (Northern Ireland) should be adhered to. If outside of the UK, please adhere to your own country's regulations for unvented hot water systems.

Connect the flow for the DHW to pipe A (Figure 3.1).

The function of the following safety components of the cylinder unit should be checked on installation for any abnormalities;

- Pressure relief valve (primary circuit and tank)
- Expansion vessel pre-charge (gas charge pressure)

The instruction on the following pages regarding safe discharge of hot water from safety devices should be followed carefully.

- The pipework will become very hot, so should be insulated to prevent burns.
- When connecting pipework, ensure that no foreign objects such as debris or the like enter the pipe.

■ Cold Water Pipework

Cold water to the suitable standard (see section 4.2) should be introduced to the system by connecting pipe B (Figure 3.1) using appropriate fittings.

■ Primary Pump Circulation

If there are thermostatic or motorized valves on the installation, at least one of the valves on each zone must remain open to enable routine water circulation. (preferably on the largest or furthest emitter).

■ Drain Pipework (ONLY ER series)

The drain should be set from the drain socket at left rear of the unit.

The drain pipe should be installed to drain condensed water during cooling mode. Close the drain socket hole when cooling operation is not used.

- To prevent dirty water from draining directly onto the floor next to cylinder unit, please connect appropriate discharge pipework from the cylinder drain pan.
- Securely install the drain pipe to prevent leakage from the connection.
- Securely insulate the drain pipe to prevent water dripping from the locally supplied drain pipe.
- Install the drain pipe at a down slope of 1/100 or more.
- Do not place the drain pipe in drain channel where sulphuric gas exists.
- After installation, check that the drain pipe drains water properly from the outlet of the pipe to suitable discharge location.
- The drain hose should be connected to the drainage hole that is in the room.

■ Negative pressure prevention

To prevent negative pressure effecting DHW tank, installer should install appropriate pipework or use appropriate devices.

■ Hydraulic filter work (ONLY E*PT series)

Install a hydraulic filter or strainer (local supply) at the water intake ("Pipe E" in Fig.3.1)

■ Pipework Connections

Connections to the cylinder unit should be made using the G-screw connection.

Note: Before brazing pipes in the field, protect pipes on the cylinder unit using wet towels, etc. as "heat shield".

■ Insulation of Pipework

- All exposed water pipework should be insulated to prevent unnecessary heat loss and condensation. To prevent condensate entering the cylinder unit, the pipework and connections at the top of the cylinder unit should be carefully insulated.
- Cold and hot water pipework should not be run close together where possible, to avoid unwanted heat transfer.
- Pipework between outdoor heat pump unit and cylinder unit should be insulated with suitable pipe insulation material with a thermal conductivity of ≤ 0.04 W/m.K.

<Installation>

1. The drain socket (inside diameter 26 mm) is left rear of the cylinder unit. (Figure 4.3.1)
2. Fix the drain pipe (VP-20) which fits the drain socket with the polyvinyl chloride type adhesive.
3. Set the drain pipework up to the outlet with the down grade of more than one hundredth.

Note: Securely support the locally supplied drain pipe to avoid the drain pipe falling from the drain socket.

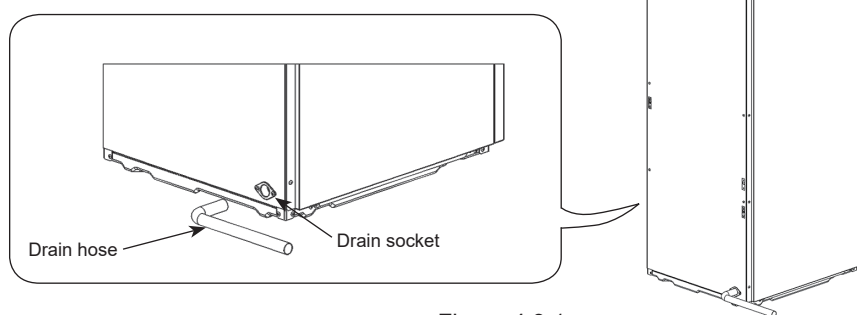

<Figure 4.3.1>

4 Installation

■ Sizing Expansion Vessels

Expansion vessel volume must fit the local system water volume.

To size an expansion vessel for the heating circuit, the following formula and graph can be used.

When the necessary expansion vessel volume exceeds the volume of a built-in expansion vessel, install an additional expansion vessel so that the sum of the volumes of the expansion vessels exceeds the necessary expansion vessel volume.

* For installation of an E**T***.*M*EE* model, it is essential to appropriately provide and install a suitable primary-side expansion vessel in the field as the model **DOES NOT** come fitted with a primary-side expansion vessel.

$$V = \frac{\varepsilon \times G}{1 - \frac{P_1 + 0.098}{P_2 + 0.098}}$$

Where;

V : Necessary expansion vessel volume [L]

ε : Water expansion coefficient

G : Total volume of water in the system [L]

P₁ : Expansion vessel setting pressure [MPa]

P₂ : Max. pressure during operation [MPa]

Graph to the right is for the following values

ε : at 70°C = 0.0229

P₁ : 0.1 MPa

P₂ : 0.3 MPa

*A 30% safety margin has been added.

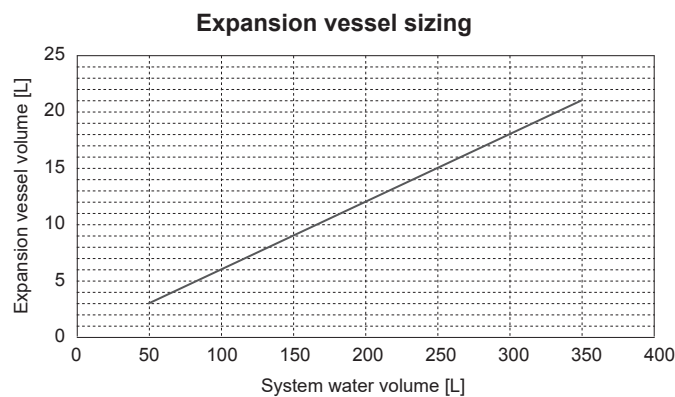

<Figure 4.3.2>

■ Filling the System (Primary Circuit)

1. Check and charge expansion vessel.
2. Check all connections including factory fitted ones are tight.
3. Insulate pipework between cylinder unit and outdoor unit.
4. Thoroughly clean and flush all debris from the system.
(see section 4.2 for instruction.)
5. Fill cylinder unit with potable water. Fill primary heating circuit with water and suitable anti-freeze and inhibitor as necessary. **Always use a filling loop with double check valve when filling the primary circuit to avoid back flow contamination of water supply.**
6. Check for leakages. If leakage is found, retighten the screws onto the connections.

- Anti-freeze should always be used for packaged model systems (see section 4.2 for instruction). It is the responsibility of the installer to decide if anti-freeze solution should be used in split model systems depending on each site's conditions. Corrosion inhibitor should be used in both split model and packaged model systems.

Figure 4.3.3 shows freezing temperature against anti-freeze concentration. This figure is an example for FERNOX ALPHI-11. For other anti-freeze, please refer to relevant manual.

- When connecting metal pipes of different materials insulate the joints to prevent a corrosive reaction taking place which will damage the pipework.

7. Pressurise system to 1 bar.
8. Release all trapped air using air vents during and following heating period.
9. Top up with water as necessary. (If pressure is below 1 bar)
10. After removing the air, automatic air vent **MUST** be closed.

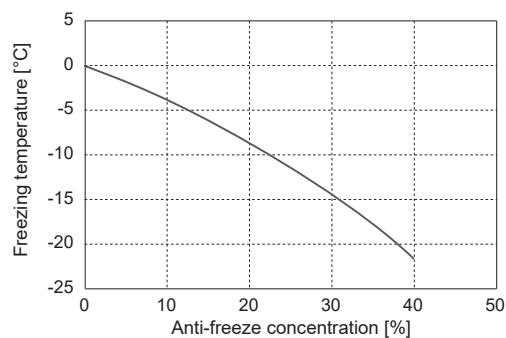

<Figure 4.3.3>

<Draining the cylinder unit>

CAUTION: DRAINED WATER MAY BE VERY HOT

1. Firstly to eliminate any air in heat pump unit pipe works, engage the DHW pump circulator for 1-2 mins and expel any trapped air via nearest hot water tap so as unit becomes fully primed/water charged.
2. Before attempting to drain the cylinder unit isolate from the electrical supply to prevent the immersion and booster heaters burning out.
3. Isolate cold water feed to DHW tank.
4. Open a hot water tap to allow draining without creating a vacuum.
5. Attach a hose to the DHW tank drain cocks (No. 22 and 23 on Figure 4.3.4). The hose should be able to withstand heat as the draining water could be very hot. The hose should drain to a place lower than the DHW tank bottom to encourage siphoning. Begin draining by opening drain cock.
6. When the DHW tank is drained close drain cock and hot tap.
7. For primary circuit, attach hose to water circuit drain cocks (No. 6 on Figure 3.1). The hose should be able to withstand heat as the draining water could be very hot. The hose should drain to a place lower than the drain cock to encourage siphoning.
8. Water remains in the strainer still after the cylinder unit was drained.
Drain the strainer by removing the strainer cover. (No. 12 on Figure 3.1)

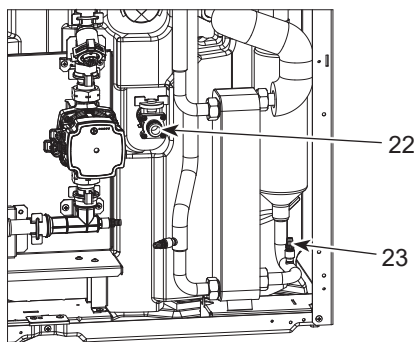

<Figure 4.3.4>

4 Installation

Water Circulation Pump Characteristics

1. Primary circuit

Pump speed can be selected by main remote controller setting (see Figure 4.3.5). Adjust the pump speed setting so that the flow rate in the primary circuit is appropriate for the outdoor unit installed (see Table 4.3.1). It may be necessary to add an additional pump to the system depending on the length and lift of the primary circuit.

For outdoor unit model not listed in Table 4.3.1, refer to the water flow rate range in the specification table of outdoor unit Data Book.

<Second pump >

If a second pump is required for the installation, please read the following carefully. If a second pump is used in the system, it can be positioned in 2 ways. The position of the pump influences which terminal of the FTC the signal cable should be wired to. If the additional pump(s) have current greater than 1A, please use appropriate relay. Pump signal cable can either be wired to TBO.1 1-2 or CNP1 but NOT both.

Option 1 (Space heating/cooling only)

If the second pump is being used for the heating circuit, only then the signal cable should be wired to TBO.1 terminals 3 and 4 (OUT2). In this position, the pump can be run at a different speed to the cylinder unit's in-built pump.

Option 2 (Primary circuit DHW and space heating/cooling)

If the second pump is being used in the primary circuit between the cylinder unit and the outdoor unit (Package system ONLY), then the signal cable should be wired to TBO.1 terminals 1 and 2 (OUT1). In this position, the pump speed **MUST** match the speed of the cylinder unit's in-built pump.

Note: Refer to 5.2 Connecting inputs/outputs.

2. Sanitary circuit

Default setting: Speed 2
DHW circulation pump **MUST** be set to speed 2.

Outdoor heat pump unit		Water flow rate range [L/min]	Recommended flow [L/min] *1
Packaged model	PUZ-WZ50	6.5 - 14.3	7.2
	PUZ-WZ60	6.5 - 17.2	9.0
	PUZ-WZ80	6.5 - 22.9	10.8
Split model SUZ series	SUZ-SWM30VA	6.5 - 11.4	7.2
	SUZ-SWM40VA2	6.5 - 11.4	7.2
	SUZ-SWM60VA2	7.2 - 17.2	10.8
	SUZ-SWM80VA(H)2	10.8 - 21.5	13.4
	SUZ-SWM100VA(H)	10.8 - 25.8 *3	16.1
	SUZ-SHWM30VAH	6.5 - 11.4	7.2
	SUZ-SHWM40VAH	6.5 - 17.2	7.2
Split model PUZ series	PUZ-S(H)WM60	7.2 - 22.9	10.8
	PUZ-S(H)WM80	7.2 - 22.9	14.3
	PUZ-S(H)WM100	7.2 - 28.7	17.9
	PUZ-S(H)WM120	9.0 - 34.4 *3	21.5 *2
	PUZ-S(H)WM140	9.0 - 34.4 *3	25.1 *2
Split model Multi series	PUMY-P112	17.9 - 35.8 *3	25.1 *2
	PUMY-P125	17.9 - 35.8 *3	28.7 *2
	PUMY-P140	17.9 - 35.8 *3	29.6 *2
	PXZ-4F75VG	11.5 - 21.7	13.4
	PXZ-5F85VG	11.5 - 24.6 *3	15.2

<Table 4.3.1>

Notes:

- If the primary water flow rate is less than the minimum flow rate setting of the flow sensor (default 5.0 L/min), the flow rate error will be activated.
- If the primary water flow rate exceeds 36.9 L/min (E**T20/30 series) or 25.8 L/min (E**T17 series), the flow speed will be greater than 2.0 m/s, which could erode the pipes.

*1 Flow rate recommended for installation

*2 With buffer tank

*3 If you want to secure the maximum flow rate, please install an additional pump.

Water circulation pump characteristics

E*PT20/30X series

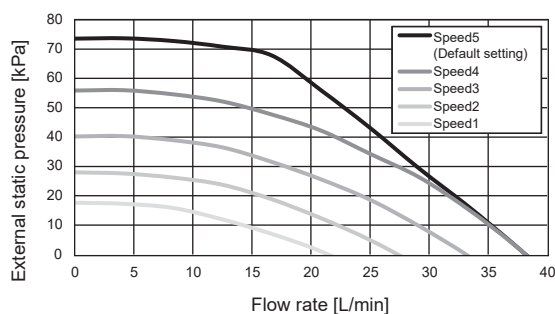

<Figure 4.3.5>

Note: For installation of E*PT series, set its pump speed with a pressure drop between the cylinder unit and the outdoor unit factored into the external static pressure.

4 Installation

■ Immersion heater

When an immersion heater is fitted, do NOT energise the heater until the DHW tank is full of water. Also do NOT energise any immersion heater if any sterilisation chemicals remain in the DHW tank as this will cause premature failure of the heater.

■ Safety Device Connections

The expansion relief valve on the secondary hot water side, and the temperature and pressure (T&P) relief valve (*A), both need appropriate discharge pipework. There must be no valve fitted between the expansion relief valve and the tank.

*A EHPT20X-MEHEW is equipped with factory-fitted T & P relief valve on the tank (2). Any other models are equipped with Pressure relief valve, fitted to the DHW pipework (3).

Note : 1. Do not secure the screws excessively when connecting the Discharge pipe, otherwise it may result in damage to the cylinder unit.

<For UK>

The right side panel has a plate (*B) so that connection can be made to the factory fitted temperature and pressure relief valve. If you wish to make the connection in a different position you will have to cut a hole in the side panel yourself. However it remains necessary that the drainage parameters outlined in the appropriate Building Regulations are complied with.

*B Unscrew the plate on the right-side panel, connect the Pressure relief valve to the discharge pipework, and refit the plate. Always replace the plate so that no gaps exist between the plate and side panel and the plate and drain pipe to avoid heat loss.

In accordance with Building Regulations a tundish must be fitted into the pipework within 500 mm of the safety device (also see Figure 4.4.1). Due to the distance between the two safety devices it may be necessary to fit each safety device with its own tundish before you run the pipework together to a safe discharge (see Figure 4.3.6).

Note : 2. Alternatively the discharges from the expansion relief valve and T&P relief valve may commonly discharge to a singular tundish, so long as this tundish is located within 500 mm of the T&P relief valve in UK. When connecting discharge pipes to the safety devices, beware not to strain the inlet connections.

Diagram part No.	Description	Connection size	Connection type
1	Expansion relief valve (part of inlet control group)	15 mm	Compression
2	T&P relief valve	15 mm /G 1/2	Compression/ Female
3	Pressure relief valve	G 1/2	Female

<Table 4.3.2>

Always refer to local regulations when installing discharge pipework. Install discharge pipework in a frost-free environment. It is necessary to provide appropriate drainage from the pressure relief valve situated on top of the cylinder unit to prevent damage to the unit and the surrounding area from any steam or hot water released. Relief valves MUST NOT be used for any other purpose.

For UK use WK02UK-E kit, for other countries please see below;

- Any discharge pipework should be capable of withstanding discharge of hot water. Discharge pipework should be installed in a continuously downward direction. Discharge pipework must be left open to the environment.

■ Piping diagram for 2-zone temperature control

Connect the pipe work and locally supplied parts according to the relevant circuit diagram shown in Section 3. Technical Information, of this manual. For more details on wiring, refer to "5.3 Wiring for 2-zone temperature control".

Note: Do not install the thermistors on the mixing tank. This could affect correct monitoring of flow and return temperatures through each zone. Install the Zone2 flow temp. thermistor (THW8) near the mixing valve.

<UK model> EHPT20X-MEHEW

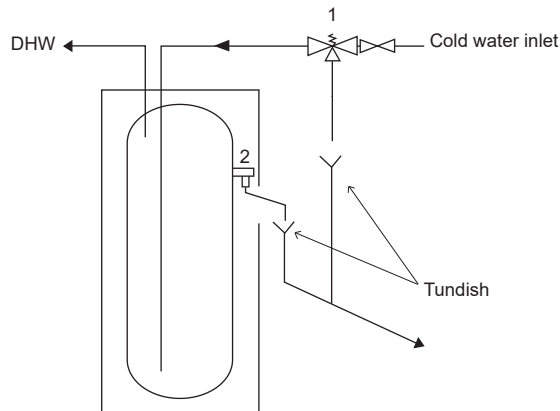

<Other models>

The expansion vessel on the sanitary water side shall be installed as necessary in accordance with your local regulations.

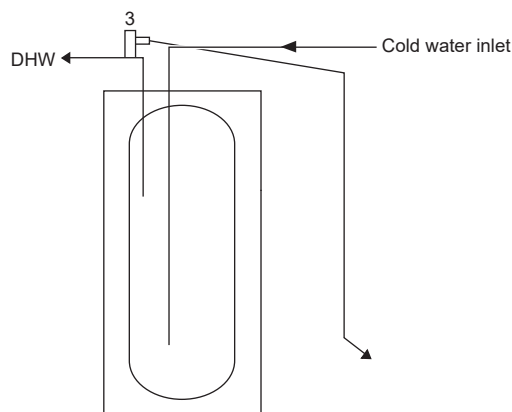

<Figure 4.3.6>

4 Installation

4.4 Safety Device Discharge Arrangements (G3)

The following instructions are a requirement of UK Building Regulations and must be adhered to. For other countries please refer to local legislation. If you are in any doubt please seek advice from local building planning office.

1. Position the inlet control group so that discharge from both safety valves can be joined together via a 15 mm end feed Tee.
2. Connect the tundish and route the discharge pipe as shown in Figure 4.4.1.
3. The tundish should be fitted vertically and as close to the safety device as possible and within 500 mm of the device.
4. The tundish should be visible to occupants and positioned away from electrical devices.
5. The discharge pipe (D2) from the tundish should terminate in a safe place where there is no risk to persons in the vicinity of the discharge, be of metal construction and:

A) Be at least one pipe size larger than the nominal outlet size of the safety device unless its total equivalent hydraulic resistance exceeds that of a straight pipe 9 m long i.e. discharge pipes between 9 m and 18 m equivalent resistance length should be at least two sizes larger than the nominal outlet size of the safety device, between 18 and 27 m at least 3 sizes larger, and so on. Bends must be taken into account in calculating the flow resistance. Refer to Figure 4.4.1, Table 4.4.1 and the worked example. An alternative approach for sizing discharge pipes would be to follow BS 6700: 1987 specification for design installation, testing and maintenance of services supplying water for domestic use within buildings and their cartilages.

B) Have a vertical section of pipe at least 300 mm long, below the tundish before any elbows or bends in the pipework.

C) Be installed with a continuous fall.

D) Have discharges visible at both the tundish and the final point of discharge but where this is not possible or is practically difficult there should be clear visibility at one or other of these locations. Examples of acceptable discharge arrangements are:

i. Ideally below a fixed grating and above the water seal in a trapped gully.

ii. Downward discharges at low level; i.e. up to 100 mm above external surfaces such as car parks, hard standings, grassed areas etc. are acceptable providing that where children may play or otherwise come into contact with discharges a wire cage or similar guard is positioned to prevent contact, whilst maintaining visibility.

iii. Discharges at high level; e.g. into a metal hopper and metal down pipe with the end of the discharge pipe clearly visible (tundish visible or not) or onto a roof capable of withstanding high temperature discharges of water and 3 m from any plastic guttering system that would collect such discharges (tundish visible).

iv. Where a single pipe serves a number of discharges, such as in blocks of flats, the number served should be limited to not more than 6 systems so that any installation discharging can be traced reasonably easily. The single common discharge pipe should be at least one pipe size larger than the largest individual discharge pipe (D2) to be connected. If unvented hot water storage systems are installed where discharges from safety devices may not be apparent i.e. in dwellings occupied by blind, infirm or disabled people, consideration should be given to the installation of an electronically operated device to warn when discharge takes place.

Note: The discharge will consist of scalding water and steam. Asphalt, roofing felt and nonmetallic rainwater goods may be damaged by such discharges.

Worked example: The example below is for a G½ temperature relief valve with a discharge pipe (D2) having 4 No. elbows and length of 7 m from the tundish to the point of discharge.

From Table 4.4.1: Maximum resistance allowed for a straight length of 22 mm copper discharge pipe (D2) from a G½ temperature relief valve is: 9.0 m subtract the resistance for 4 No. 22 mm elbows at 0.8 m each = 3.2 m. Therefore the maximum permitted length equates to: 5.8 m. 5.8 m is less than the actual length of 7 m, therefore calculate the next largest size. Maximum resistance allowed for a straight length of 28 mm pipe (D2) from a G½ temperature relief valve equates to: 18 m

Subtract the resistance for 4 No. 28 mm elbows at 1.0 m each = 4 m. Therefore the maximum permitted length equates to: 14 m. As the actual length is 7 m, a 28 mm (D2) copper pipe will be satisfactory.

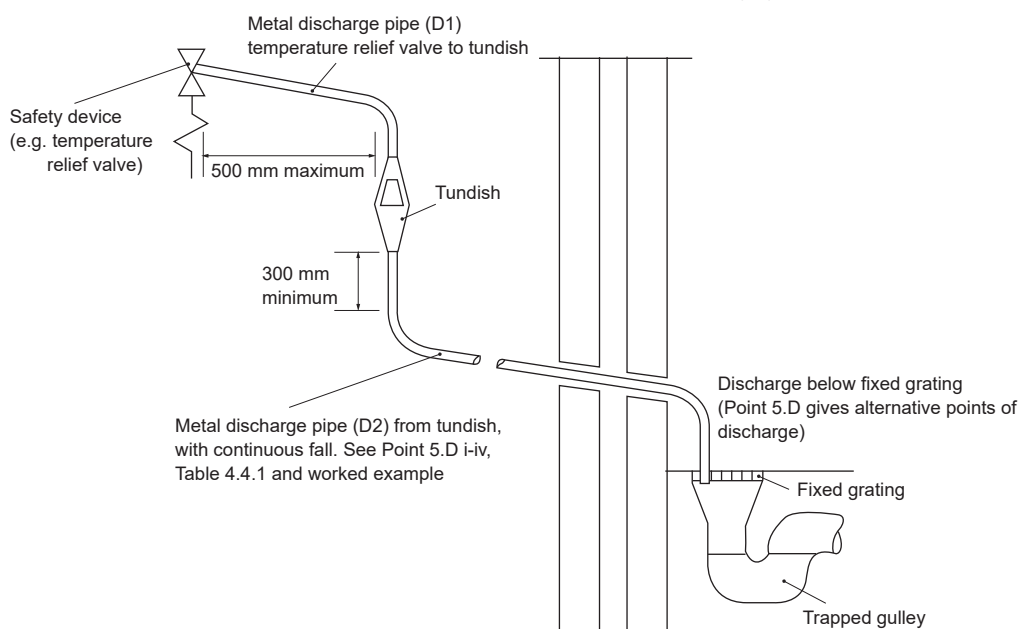

<Figure 4.4.1>

Valve outlet size	Minimum size of discharge pipe D1	Minimum size of discharge pipe D2 from tundish	Maximum resistance allowed, expressed as a length of straight pipe (no elbows or bends)	Resistance created by each elbow or bend
G 1/2	15 mm	22 mm	Up to 9 m	0.8 m
		28 mm	Up to 18 m	1.0 m
		35 mm	Up to 27 m	1.4 m
G 3/4	22 mm	28 mm	Up to 9 m	1.0 m
		35 mm	Up to 18 m	1.4 m
		42 mm	Up to 27 m	1.7 m
G1	28 mm	35 mm	Up to 9 m	1.4 m
		42 mm	Up to 18 m	1.7 m
		54 mm	Up to 27 m	2.3 m

<Table 4.4.1>

4 Installation

4.5 Electrical Connection

All electrical work should be carried out by a suitably qualified technician. Failure to comply with this could lead to electrocution, fire, and death. It will also invalidate product warranty. All wiring should be according to national wiring regulations.

Breaker abbreviation	Meaning
ECB1	Earth leakage circuit breaker for booster heater
ECB2	Earth leakage circuit breaker for immersion heater
TB1	Terminal block 1

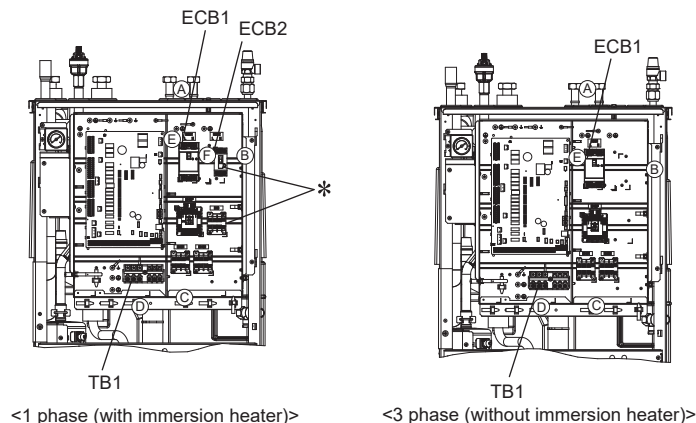

The cylinder unit can be powered in two ways.

1. Power cable is run from the outdoor unit to the cylinder unit.
2. Cylinder unit has independent power source.

Connections should be made to the terminals indicated in the figures to the left below depending on the phase.

Booster heater and immersion heater should be connected independently from one another to dedicated power supplies.

- Locally supplied wiring should be inserted through the inlets situated on the top of the cylinder unit. (Refer to Table 3.6.)
- Wiring should be fed down the right hand side of the control and electrical box and clamped in place using clips provided.
- The wires should be inserted individually through the cable inlets as below.
 - Outputs wire
 - Indoor-Outdoor wire
 - Power line (B.H.)/ Power line (I.H.) (Option)
 - Signal input wires
- Connect the outdoor unit – cylinder unit connecting cable to TB1.
- Connect the power cable for the booster heater to ECB1.
- If immersion heater is present, connect the power cable to ECB2.

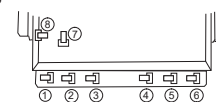

- Avoid contact between wiring and parts (*).
- Make sure that ECB1 and ECB2 are ON.
- On completion of wiring, ensure main remote controller cable is connected to the relay connector.

Cylinder unit powered via outdoor unit

(If you want to use independent source, go to the Mitsubishi Electric website.)

PXZ model is not available.

The model is cylinder unit powered by independent source ONLY.

<1 phase>

Affix label A that is included with the manuals near each wiring diagram for cylinder unit and outdoor units.

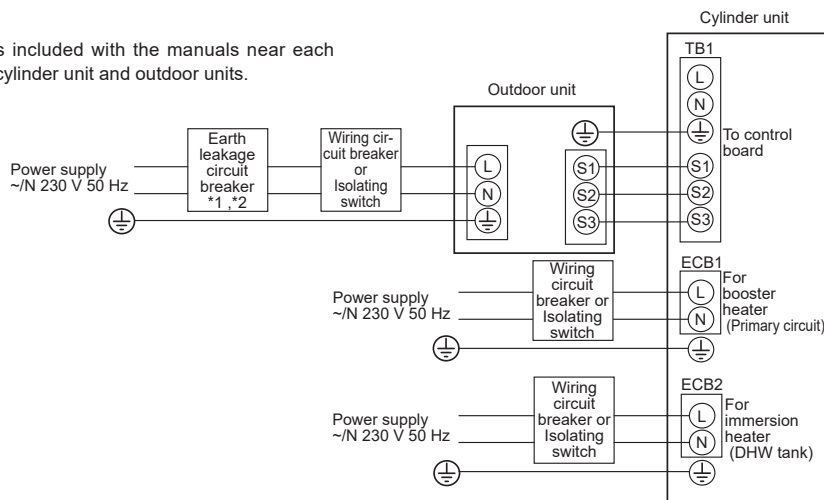

- *1. If the installed earth leakage circuit breaker does not have an over-current protection function, install a breaker with that function along the same power line.
- *2. A breaker with at least 3.0 mm contact separation in each pole shall be provided. Use earth leakage circuit breaker (NV). The breaker shall be provided to ensure disconnection of all active phase conductors of the supply.
- *3. Max. 45 m
If 2.5 mm² used, Max. 50 m
If 2.5 mm² used and S3 separated, Max. 80 m
- *4. The values given in the table below are not always measured against the ground value.

<Figure 4.5.1>
Electrical connections 1 phase

Description	Power supply	Capacity	Breaker	Wiring
Booster heater (Primary circuit)	~N 230 V 50 Hz	2 kW	16 A *2	2.5 mm ²
		6 kW	32 A *2	6.0 mm ²
Immersion heater (DHW tank)	~N 230 V 50 Hz	3 kW	16 A *2	2.5 mm ²

Wiring No. × size (mm ²)	Cylinder unit - Outdoor unit	*3	3 × 1.5 (polar)
	Cylinder unit - Outdoor unit earth	*3	1 × Min. 1.5
Circuit rating	Cylinder unit - Outdoor unit S1 - S2	*4	230 V AC
	Cylinder unit - Outdoor unit S2 - S3	*4	24 V DC

- Notes:
1. Wiring size must comply with the applicable local and national codes.
 2. Indoor unit/outdoor unit connecting cords shall not be lighter than polychloroprene sheathed flexible cord. (Design 60245 IEC 57)
Indoor unit power supply cords shall not be lighter than polychloroprene sheathed flexible cord. (Design 60227 IEC 53)
 3. Install an earth longer than other cables.
 4. Please keep enough output capacity of power supply for each heater. Insufficient power supply capacity might cause chattering.

4 Installation

<3 phase>

Affix label A that is included with the manuals near each wiring diagram for cylinder unit and outdoor units.

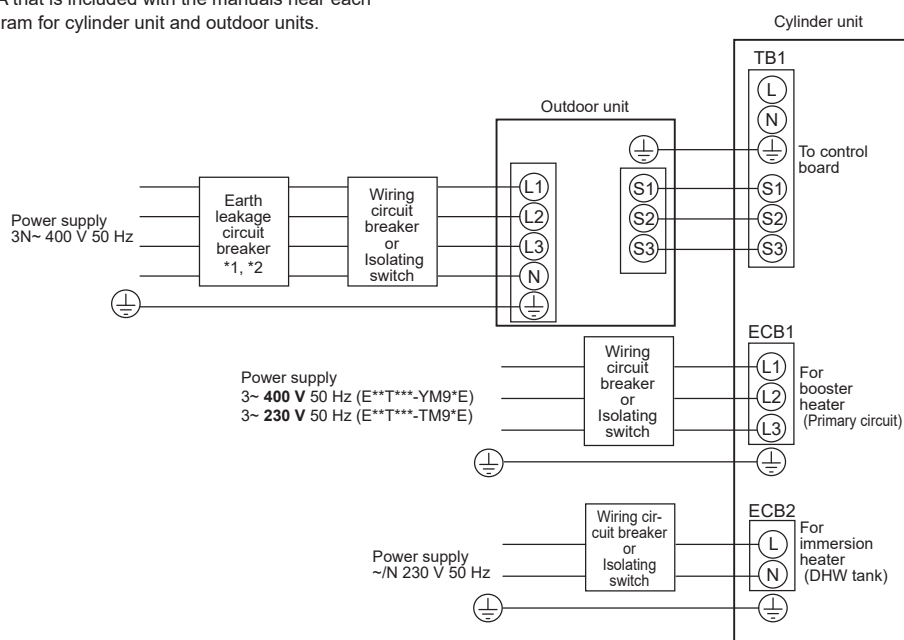

<Figure 4.5.2>
Electrical connections 3 phase

Description	Power supply	Capacity (Indoor unit Ref.)	Breaker	Wiring
Booster heater (Primary circuit)	3~ 400 V 50 Hz	9 kW	16 A *2	2.5 mm ²
	3~ 230 V 50 Hz	9 kW	32 A *2	6.0 mm ²
Immersion heater (DHW tank)	~N 230 V 50 Hz	3 kW	16 A *2	2.5 mm ²

Wiring No. × size (mm ²)	Cylinder unit - Outdoor unit	*3	3 × 1.5 (polar)
	Cylinder unit - Outdoor unit earth	*3	1 × Min. 1.5
Circuit rating	Cylinder unit - Outdoor unit S1 - S2	*4	230 V AC
	Cylinder unit - Outdoor unit S2 - S3	*4	24 V DC

- *1. If the installed earth leakage circuit breaker does not have an over-current protection function, install a breaker with that function along the same power line.
- *2. A breaker with at least 3.0 mm contact separation in each pole shall be provided. Use earth leakage circuit breaker (NV). The breaker shall be provided to ensure disconnection of all active phase conductors of the supply.
- *3. Max. 45 m
If 2.5 mm² used, Max. 50 m
If 2.5 mm² used and S3 separated, Max. 80 m
- *4. The values given in the table above are not always measured against the ground value.

- Notes:**
1. Wiring size must comply with the applicable local and national codes.
 2. Indoor unit/outdoor unit connecting cords shall not be lighter than polychloroprene sheathed flexible cord. (Design 60245 IEC 57)
Indoor unit power supply cords shall not be lighter than polychloroprene sheathed flexible cord. (Design 60227 IEC 53)
 3. Install an earth longer than other cables.
 4. Please keep enough output capacity of power supply for each heater. Insufficient power supply capacity might cause chattering.

5 System Set Up

5.1 DIP Switch Functions

The DIP switch number is printed on the circuit board next to the relevant switches. The word ON is printed on the circuit board and on the DIP switch block itself. To move the switch, you will need to use a pin or the corner of a thin metal ruler or similar.

DIP switch settings are listed below in Table 5.1.1.

Only an authorised installer can change DIP switch setting under one's own responsibility according to the installation condition.

Make sure to turn off both indoor unit and outdoor unit power supplies before changing the switch settings.

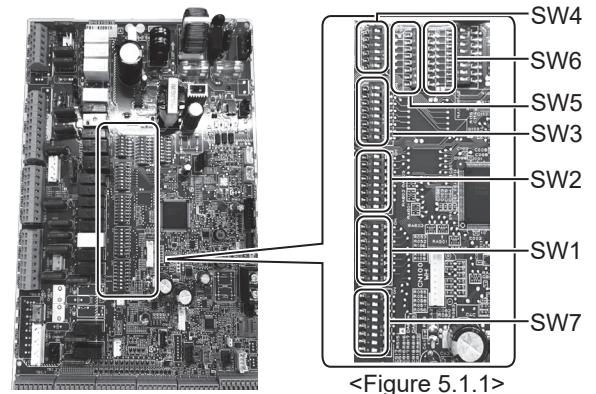

<Figure 5.1.1>

DIP switch	Function	OFF	ON	Default settings: Indoor unit model	
SW1	SW1-1 Boiler	WITHOUT Boiler	WITH Boiler	OFF	
	SW1-2 Heat pump maximum outlet water temperature	55°C	60°C	ON *1	
	SW1-3 DHW tank	WITHOUT DHW tank	WITH DHW tank	ON	
	SW1-4 Immersion heater	WITHOUT Immersion heater	WITH Immersion heater	OFF: Except EHPT20X-MEHEW ON : EHPT20X-MEHEW	
	SW1-5 Booster heater	WITHOUT Booster heater	WITH Booster heater	OFF: E**T***-M**E* ON : E**T***-M 2/6/9*E	
	SW1-6 Booster heater function	For heating only	For heating and DHW	OFF: E**T***-M**E* ON : E**T***-M 2/6/9*E	
	SW1-7 Outdoor unit type	Split type	Packaged type	OFF: E*ST***-M**E* ON : E*PT**X-*M**E*	
	SW1-8 Wireless remote controller	WITHOUT Wireless remote controller	WITH Wireless remote controller	OFF	
SW2	SW2-1 Room thermostat 1 input (IN1) logic change	Zone 1 operation stop at thermostat short	Zone 1 operation stop at thermostat open	OFF	
	SW2-2 Flow switch 1 input (IN2) logic change	Failure detection at short	Failure detection at open	OFF	
	SW2-3 Booster heater capacity restriction	Inactive	Active	OFF: Except E**T***-VM2*E ON : E**T***-VM2*E	
	SW2-4 Cooling mode function	Inactive	Active	OFF: EH*T***-M**E* ON : ER*T***-M**E	
	SW2-5 Automatic switch to backup heat source operation (When outdoor unit stops by error)	Inactive	Active *2	OFF	
	SW2-6 Mixing tank	WITHOUT Mixing tank	WITH Mixing tank	OFF: Except E*ST***-M*BE ON : E*ST***-M*BE	
	SW2-7 2-zone temperature control	Inactive	Active *3	OFF	
	SW2-8 Flow sensor	WITHOUT Flow sensor	WITH Flow sensor	ON	
SW3	SW3-1 Room thermostat 2 input (IN6) logic change	Zone 2 operation stop at thermostat short	Zone 2 operation stop at thermostat open	OFF	
	SW3-2 Flow switch 2 and 3 input logic change	Failure detection at short	Failure detection at open	OFF	
	SW3-3 3-way valve type	AC motor	Stepping motor	OFF: Except E**T17X/17D/20D-*M**E ON : E**T17X/17D/20D-*M**E	
	SW3-4 Electric energy meter	WITHOUT Electric energy meter	WITH Electric energy meter	OFF	
	SW3-5 Heating mode function *4	Inactive	Active	ON	
	SW3-6 2-zone valve ON/OFF control	Inactive	Active	OFF	
	SW3-7 Heat exchanger for DHW	Coil in tank	External plate HEX	ON	
	SW3-8 Heat meter	WITHOUT Heat meter	WITH Heat meter	OFF	
SW4	SW4-1	—	—	OFF	
	SW4-2	—	—	OFF	
	SW4-3	—	—	OFF	
	SW4-4 Indoor unit only operation (during installation work) *5	Inactive	Active	OFF	
	SW4-5 Emergency mode (Heater only operation)	Normal	Emergency mode (Heater only operation)	OFF *6	
	SW4-6 Emergency mode (Boiler operation)	Normal	Emergency mode (Boiler operation)	OFF *6	
SW5	SW5-1	—	—	OFF	
	SW5-2 Advanced auto adaptation	Inactive	Active	ON	
	SW5-3	Capacity code			
	SW5-4				
	SW5-5				
	SW5-6				
	SW5-7				
SW5-8	—	—	—	OFF	
SW6	SW6-1	—	—	OFF	
	SW6-2	—	—	OFF	
	SW6-3 Pressure sensor	Inactive	Active	OFF: Except E*ST**D/F-*M**E ON : E*ST**D/F-*M**E	
	SW6-4 Analog output signal (0-10 V)	Inactive	Active	OFF	
	SW6-5	—	—	OFF	
	SW6-6	—	—	OFF	
	SW6-7	—	—	OFF	
	SW6-8	—	—	OFF	

<Table 5.1.1>

5 System Set Up

DIP switch		Function	OFF	ON	Default settings: Indoor unit model
SW7	SW7-1	Mixing valve setting	Only Zone 2	Zone 1 and Zone 2	OFF
	SW7-2	Forced cooling mode input (IN13) logic change	Active at short	Active at open	OFF
	SW7-3	Cooling limit temp. input (IN15) logic change	Active at short	Active at open	OFF
	SW7-4	—	—	—	OFF
	SW7-5	—	—	—	OFF
	SW7-6	—	—	—	OFF
	SW7-7	—	—	—	OFF
	SW7-8	—	—	—	OFF

<Table 5.1.1>

- Notes:
- *1. When the cylinder unit is connected with a PUMY-P and PXZ outdoor unit of which maximum outlet water temperature is 55°C, DIP SW1-2 must be changed to OFF.
 - *2. External output (OUT11) will be available. For safety reasons, this function is not available for certain errors. (In that case, system operation must be stopped and only the water circulation pump keeps running.)
 - *3. Active only when SW3-6 is set to OFF.
 - *4. This switch functions only when the cylinder unit is connected with a PUHZ-FRP outdoor unit. When another type of outdoor unit is connected, the heating mode function is active regardless of the fact that this switch is ON or OFF.
 - *5. Space heating and DHW can be operated only in indoor unit, like an electric heater. (Refer to "5.4 Indoor unit only operation".)
 - *6. If emergency mode is no longer required, return the switch to OFF position.

5.2 Connecting inputs/outputs

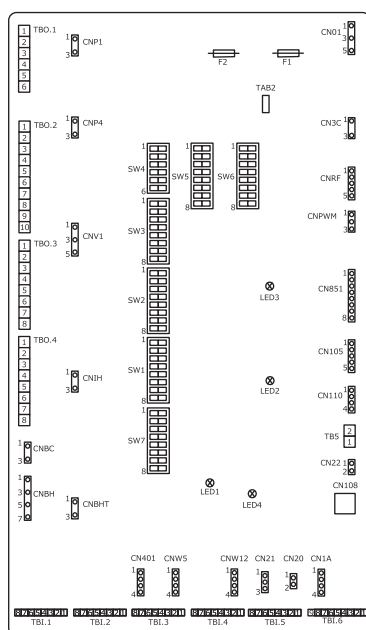

<Figure 5.2.1>

5 System Set Up

■ Outputs

Name	Terminal block	Connector	Item	OFF	ON	Signal/Max current	Max. total current
OUT1	TBO.1 1-2	CNP1	Water circulation pump 1 output (Space heating/cooling & DHW)	OFF	ON	230 V AC 1.0 A Max. (Inrush current 40 A Max.)	4.0 A (a)
OUT2	TBO.1 3-4	—	Water circulation pump 2 output (Space heating/cooling for Zone 1)	OFF	ON	230 V AC 1.0 A Max. (Inrush current 40 A Max.)	
OUT3	TBO.1 5-6	—	Water circulation pump 3 output (Space heating/cooling for Zone 2) *1 2-way valve 2b output *2	OFF	ON	230 V AC 1.0 A Max. (Inrush current 40 A Max.)	
OUT14	—	CNP4	Water circulation pump 4 output (DHW)	OFF	ON	230 V AC 1.0 A Max. (Inrush current 40 A Max.)	
OUT4	TBO.2 7-9	—	3-way valve SPST (2-way valve 1) output	Heating	DHW	230 V AC 0.1 A Max.	3.0 A (b)
	TBO.2 8-10	CNV1	3-way valve SPDT output				
	—	CN851	3-way valve output				
OUT5	TBO.2 1-2	—	Zone 2 mixing valve output *1	Stop	Close	230 V AC 0.1 A Max.	
	TBO.2 2-3	—		Open			
OUT6	—	CNBH 1-3	Booster heater 1 output	OFF	ON	230 V AC 0.5 A Max. (Relay)	
OUT7	—	CNBH 5-7	Booster heater 2 output	OFF	ON	230 V AC 0.5 A Max. (Relay)	
OUT8	TBO.4 7-8	—	Cooling signal output	OFF	ON	230 V AC 0.5 A Max.	
OUT9	TBO.4 5-6	CNIH	Immersion heater output	OFF	ON	230 V AC 0.5 A Max. (Relay)	
OUT10	TBO.3 1-2	—	Boiler output	OFF	ON	non-voltage contact ·220 - 240 V AC (30 V DC) ·0.5 A or less ·10 mA 5 V DC or more	—
OUT11	TBO.3 5-6	—	Error output	Normal	Error	230 V AC 0.5 A Max.	3.0 A (b)
OUT12	TBO.3 7-8	—	Defrost output	Normal	Defrost	230 V AC 0.5 A Max.	
OUT13	TBO.4 3-4	—	2-way valve 2a output *2	OFF	ON	230 V AC 0.1 A Max.	
OUT15	TBO.4 1-2	—	Comp ON signal	OFF	ON	230 V AC 0.5 A Max.	
OUT16	TBO.3 3-4	—	Heating/Cooling thermo ON signal	OFF	ON	non-voltage contact ·220 - 240 V AC (30 V DC) ·0.5 A or less ·10 mA 5 V DC or more	—
OUT18	TBO.2 4-5	—	Zone 1 mixing valve output *1	Stop	Close	230 V AC 0.1 A Max.	
	TBO.2 5-6	—			Open		
OUTA1	TBI.6 1-2	—	Analog output	0 - 10 V	0 - 10 V DC 5 mA max.	—	

Do not connect to the terminals that are indicated as “—” in the “Terminal block” field.

*1 For 2-zone temperature control.

*2 For 2-zone valve ON/OFF control.

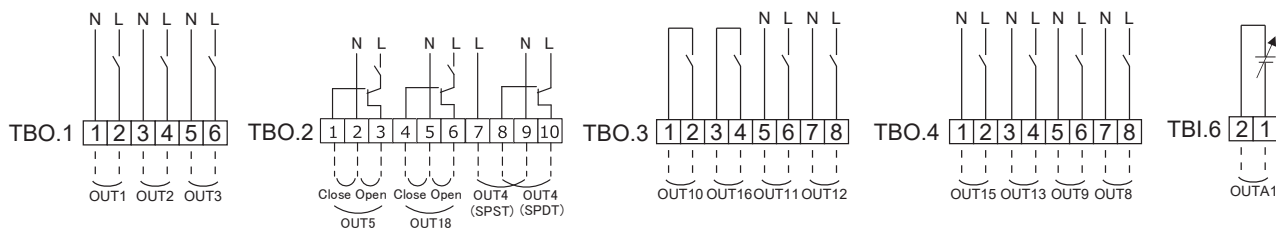

How to use TBO.1 to 4

Wiring specification and local supply parts

Item	Name	Model and specifications
External output function	Outputs wire	Use sheathed vinyl coated cord or cable. Max. 30 m Wire type: CV, CVS or equivalent Wire size: Stranded wire 0.25 mm ² to 1.5 mm ² Solid wire: ø0.57 mm to ø1.2 mm

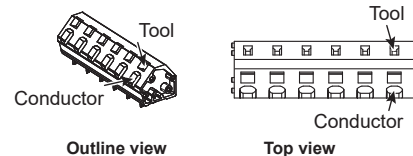

Connect them using either way as shown above.
<Figure 5.2.3>

- Notes:
1. When the cylinder unit is powered via outdoor unit, the maximum grand total current of (a)+(b) is 3.0 A.
 2. Do not connect multiple water circulation pumps directly to each output (OUT1, OUT2, and OUT3). In such a case, connect them via (a) relay(s).
 3. Do not connect water circulation pumps to both TBO.1 1-2 and CNP1 at the same time.
 4. Connect an appropriate surge absorber to OUT10 (TBO.3 1-2) depending on the load at site.
 5. Stranded wire should be processed with insulation-covered bar terminal (DIN46228-4 standard compatible type).
 6. Use the same thing as the signal input wire for OUTA1 wiring.

5 System Set Up

5.3 Wiring for 2-zone temperature control

Connect the pipe work and locally supplied parts according to the relevant circuit diagram shown in "Local system" in Section 3, of this manual.

<Mixing valve>

• Zone1

Connect the signal line to open Port A (hot water inlet port) to TBO. 2-6 (Open), the signal line to open Port B (cold water inlet port) to TBO. 2-4 (Close), and the neutral terminal wire to TBO. 2-5 (N).

Zone2

Connect the signal line to open Port A (hot water inlet port) to TBO. 2-3 (Open), the signal line to open Port B (cold water inlet port) to TBO. 2-1 (Close), and the neutral terminal wire to TBO. 2-2 (N).

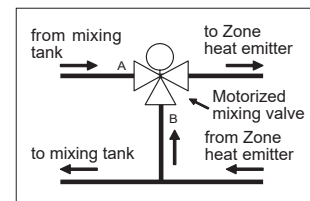
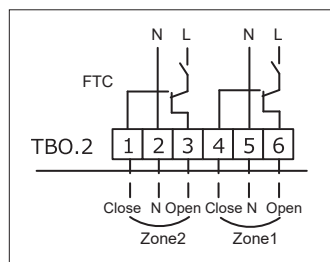

<Thermistor>

- Do not install the thermistors on the mixing tank.
- Install the thermistor (Zone 1 flow water temp.) (THW6) near the mixing valve.
- Install the thermistor (zone 2 flow water temp.) (THW8) near the mixing valve.
- The maximum length of the thermistor wiring is 30 m.
- The length of the optional thermistors are 5 m. If you need to splice and extend the wirings, following points must be carried out.
 - 1) Connect the wirings by soldering.
 - 2) Insulate each connecting point against dust and water.

DIP Switch settings of cylinder unit (hydrobox)

Setting the following DIP switches are necessary for 2-zone control.

DIP switch	Function	OFF	ON	Setting when using 2-zone kit
SW2-6	Mixing tank	WITHOUT Mixing tank	WITH Mixing tank	ON
SW2-7	2-zone temperature control	Inactive	Active *	ON
SW7-1	Mixing valve setting	Only Zone2	Zone1 and Zone2	OFF

* Active only when SW3-6 is set to OFF.

Specifications

Model name	PAC-TZ02-E2
Dimension	265 mm × 383 mm × 383 mm
Weight	17 kg
Power supply	230 V/single phase/50 Hz from cylinder unit (hydrobox)
Sound pressure level	28 dB(A)
Sound power level	40 dB(A)
Pump 2, 3	Max. 52 W/0.52 A
	Max. head 7.0 m ¹¹
Mixing valve	5 W
	Running time 90° 120s
Water flow rate range	Depend on outdoor unit

Note:

- Max. flow rate is 36.9 L/min. If the flow rate exceeds 36.9L/min, pipes would be eroded.
- The water flow rate between the cylinder unit (hydrobox) and the 2-zone kit must be greater than the total flow rate of Zone 1 and Zone 2.

Pump performance view

Display	Performance in % of MAX consumption
One green LED	0
Two green LED	0-25
Two green LED + one yellow LED	25-50
Two green LED + two yellow LED	50-75
Two green LED + three yellow LED	75-100

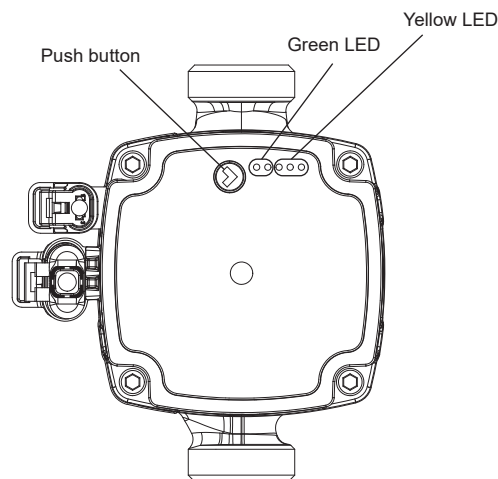

Pump key lock function

If you press the push button for more than 10 seconds, you can toggle between enabling/disabling the key lock function.

5 System Set Up

Pump setting selection

You can check the setting by pressing the push button.

If you press the button for 2 to 10 seconds, the user interface switches to "setting selection" if the user interface is unlocked.

You can change the settings as below table.

Mode	LED1 green	LED2 green	LED3 yellow	LED4 yellow	LED5 yellow
PP1	•		•		
PP2	•		•	•	
PP3	•		•	•	•
PP AA	•				
CP1		•	•		
CP2		•	•	•	
CP3		•	•	•	•
CP AA		•			
CC1			•		
CC2			•	•	
CC3			•	•	•

PP: Proportional Pressure

The head (pressure) is reduced at falling heat demand and increased at rising heat demand.

PP1: lowest proportional pressure curve

PP2: intermediate proportional pressure curve

PP3: highest proportional pressure curve

PP Auto Adapt: highest to lowest proportional pressure curve

The Auto Adapt function enables the circulator to adjust the pump performance automatically to the size of the system or the variations in load over time.

<Proportional Pressure>

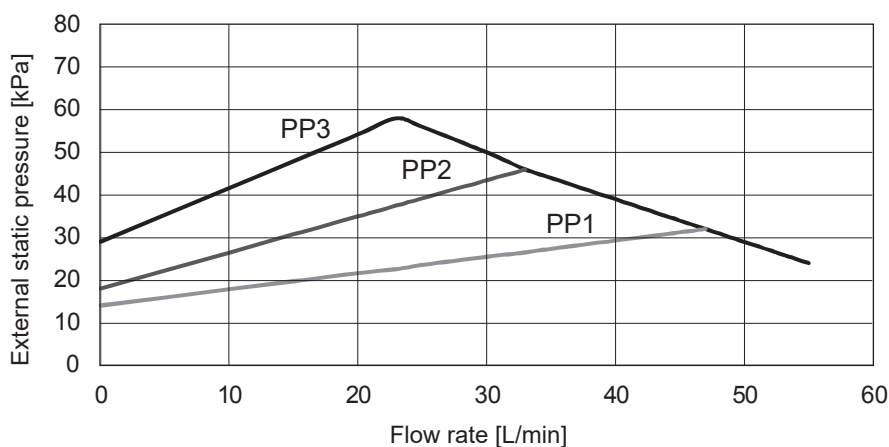

CP: Constant Pressure

The head (pressure) is kept constant, irrespective of the heat demand.

CP1: lowest constant pressure curve

CP2: intermediate constant pressure curve

CP3: highest constant pressure curve

CP Auto Adapt: highest to lowest constant pressure curve

The Auto Adapt function enables the circulator to adjust the pump performance automatically to the size of the system or the variations in load over time.

<Constant Pressure>

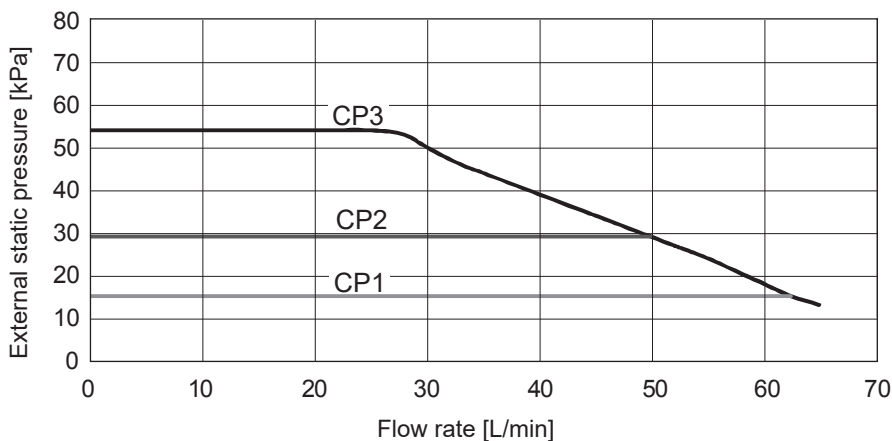

CC: Constant Curve

The circulator runs on a constant curve.

<Constant Curve>

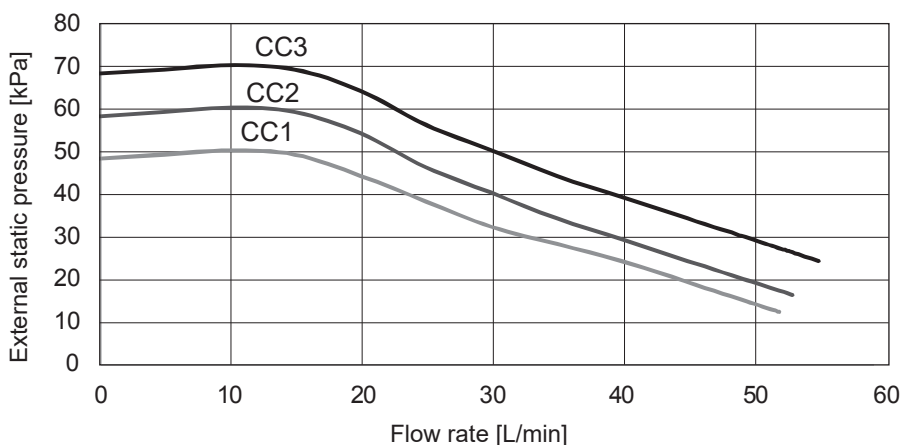

5 System Set Up

5.4 Indoor unit only operation (during installation work)

In the case when DHW or heating operation is required prior to connection of the outdoor unit; i.e. during installation work, an electric heater in indoor unit (*1) can be used.

*1 Model with electric heater only

1. To start operation

- Check if the indoor unit power supply is OFF, and turn DIP switch 4-4 and 4-5 ON.
- Turn ON the indoor unit power supply.

2. To end operation*2

- Turn OFF the indoor unit power supply.
- Turn DIP switch 4-4 and 4-5 OFF.

*2 When the indoor unit only operation is ended, ensure to check over the settings after outdoor unit is connected.

Note:

Prolonged running of this operation may affect the life of the electric heater.

5.5 Smart grid ready

In DHW, heating or cooling operation, the commands in the table below can be used.

IN11	IN12	Meaning
OFF (open)	OFF (open)	Normal operation
ON (short)	OFF (open)	Switch-on recommendation
OFF (open)	ON (short)	Switch-off command
ON (short)	ON (short)	Switch-on command

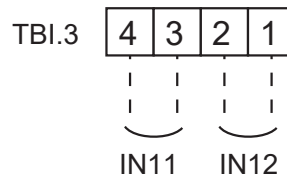

5.6 Forced cooling mode input (IN13) (only for ER series)

- When IN13 is active, the mode (heating/cooling) is fixed to cooling.
- SW7-2 changes the logic of IN13.

Name	Terminal block	DIP SW7-2	
		OFF	ON
IN13	TBI.4 3-4	Active at short (Default setting)	Active at open

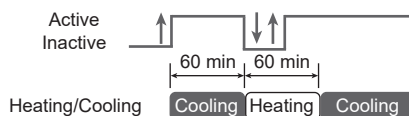

Notes:

Use non-voltage contact signals for the switch of IN13.

The mode (heating/cooling) does not switch under the condition such as

- within 60 minutes since the mode switched last time,
- during DHW mode or legionella prevention mode,
- during outdoor unit protection control,
- during emergency operation, floor dry up operation, or abnormality.

Check the mode with the main remote controller or the cooling signal output (OUT8 ON: cooling, OFF: heating).

5 System Set Up

5.7 Using microSD memory card

The cylinder unit is equipped with a microSD memory card interface in FTC.

Using a microSD memory card can simplify main remote controller settings and can store operating logs. *1

*1 To edit main remote controller settings or to check operating data, an Ecodan service tool (for use with PC) is required.

<Handling precautions>

- (1) Use a microSD memory card that complies with the SD standards. Check that the microSD memory card has a logo on it of those shown to the right.
- (2) SD memory cards to the SD standards include microSD and microSDHC memory cards. The capacities are available up to 32 GB.
- (3) Insert the microSD memory card into the FTC control board in the direction shown below.

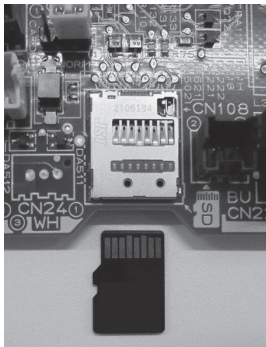

- (4) Before inserting or ejecting a microSD memory card, make sure to power off the system. If a microSD memory card is inserted or ejected with the system powered on, the stored data could be corrupted or the microSD memory card be damaged.

*A microSD memory card is live for a short duration after the system is powered off. Before insertion or ejection wait until the LED lamps on the FTC control board are all off.

- (5) The read and write operations have been verified using the following microSD memory cards, however, these operations are not always guaranteed as the specifications of these microSD memory cards could change.

Manufacturer	Model	Tested in
Vantastek	Vantastek 8GB microSDHC	Sep. 2022
Longsys	NC5MC2008G-52A39	Sep. 2022
Kingston	SDCS2/32GBSP	Sep. 2022

Before using a new microSD memory card (including the card that comes with the unit), always check that the microSD memory card can be safely read and written to by the FTC controller.

<How to check read and write operations>

- a) Check for correct wiring of power supply to the system. For more details, refer to section 4.5.
(Do not power on the system at this point.)
- b) Insert a microSD memory card.
- c) Power on the system.
- d) The LED4 lamp lights if the read and write operations are successfully completed. If the LED4 lamp continues blinking or does not light, the microSD memory card cannot be read or written to by the FTC controller.

- (6) Make sure to follow the instruction and the requirement of the microSD memory card's manufacturer.
- (7) Format the microSD memory card if determined unreadable in step (5). This could make it readable.
Download an SD card formatter from the following site.
SD Association homepage: <https://www.sdcard.org/home/>
- (8) FTC supports FAT12/FAT16/FAT32 file system but not NTFS/exFAT file system.
- (9) Mitsubishi Electric is not liable for any damages, in whole or in part, including failure of writing to a microSD memory card, and corruption and loss of the saved data, or the like. Back up saved data as necessary.
- (10) Do not touch any electronic parts on the FTC control board when inserting or ejecting a microSD memory card, or else the control board could fail.

Logos



Capacities

2 GB to 32 GB *2

SD speed classes

All

• The microSD logo is a trademark of SD-3C, LLC.

*2 A 2GB SD memory card stores up to 30 days of operation logs.

6 Remote Controller

1. Main remote controller

■ Main remote controller

To change the settings of your heating/cooling system, please use the main remote controller located on the wall or the front panel of the cylinder unit or hydrobox. The following is a guide to viewing the main settings. Should you require more information, please contact your installer or local Mitsubishi Electric dealer. Some functions are not available depending on the system configuration. These functions are grayed out or not shown.

Note: The terms displayed on the remote controller are enclosed in square brackets.

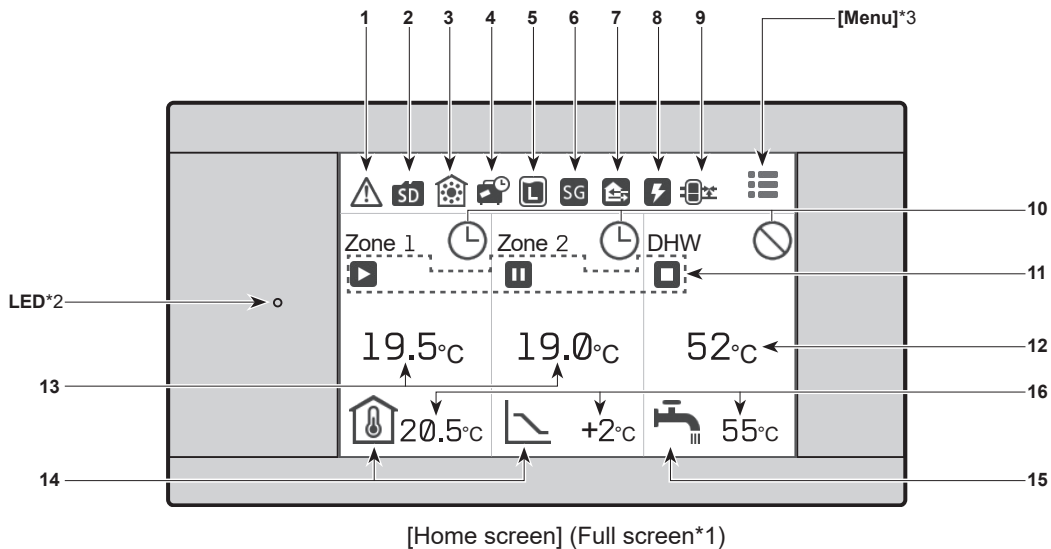

Home screen icons

No.	Icons	Description
1		Alert (for multiple outdoor units control) Touching the menu icon displays error codes.
	J1	Alert Error codes are displayed.
2		SD card is inserted. Normal operation
		SD card is inserted. Abnormal operation
3		Heating mode
		Cooling mode
4		Holiday schedule is activated.
5		Legionella prevention mode is running.
6		Smart grid ready is running.
7		Compressor is running.
		Compressor is running and defrosting.
		Compressor is running and in quiet mode. The sound level is shown at left side of the icon.
		Emergency heating
8		Electric heater is running.

No.	Icons	Description
9		Boiler is running.
		Buffer tank control is running.
10		Schedule
		Prohibited
		Cloud control
11		Operation
		Standby
		This unit is in standby whilst other indoor unit(s) is in operation by priority.
		Stop
12		Actual DHW tank temperature values
13		Actual room temperature values [-- °C] appears when the unit is not connected to the room RC (Remote Controller) and it is under control other than Auto Adaptation.

No.	Icons	Description
14		Weather compensation curve When the operation stops: Black During heating operation: Orange During cooling operation: Blue
		Auto Adaptation (Target room temperature) When the operation stops: Black During heating operation: Orange
		Flow temperature (Target flow temperature) When the operation stops: Black During heating operation: Orange During cooling operation: Blue
15		DHW icon is displayed when DHW is enabled. When the operation stops: Black During operation: Orange
		Target temperature values The settable temperature differs depending on the control logic.

- The screen will turn off when the main remote controller is not operated for a while. Touching any part of the screen turns it on again.
- From [Touch screen] in [Setting], the brightness can be adjusted.
- By selecting [Always on] for [Backlight time] from [Touch screen] in [Setting], the backlight stays lit for 30 seconds and after it dims down.

*1 From [Setting], the screen can be switched to the full screen or the base screen.
The base screen does not display the operation icons and the target temperature values.

*2 From [Display] in [Setting], the LED lamp can be turned on/off.

*3 Pressing and holding the menu icon for 3 seconds switches the lock menu to on/off.

Some functions cannot be edited when the lock menu is on.

(The icon changes to when the lock menu is on.)

*4 Auto Adaptation cannot be selected during the cooling mode.

6 Remote Controller

Quick start

When the main remote controller is switched on for the first time, the screen automatically goes to the [Language], [Date/Time], [System configuration], and quick start setting screen in order. On the quick start setting screen, the following items can be set.

Note:

[Electric booster heater use]

This setting restricts the booster heater capacity. It is NOT possible to change the setting after starting up.

If you do not have any special requirements (such as building regulations) in your country, skip this setting (select [Next]).

Quick start

- [Zone sensor selection]*1
- [Emitter selection]
- [Control logic]
- [Outdoor design temperature]
- [Zone sensor selection]*2
- [DHW]
- [Flow rate & pump speed]
- [Electric booster heater use]*3

*1 Selection of zone to assign each wireless remote controller

*2 Selection of room sensors for monitoring the room temperature

*3 It cannot be reset, so be careful when you set it.

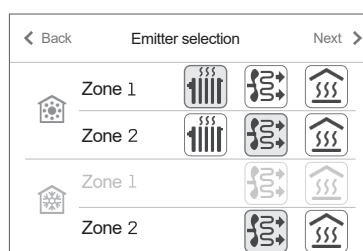
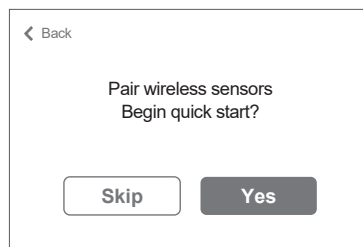

[Emitter selection]

Next setting

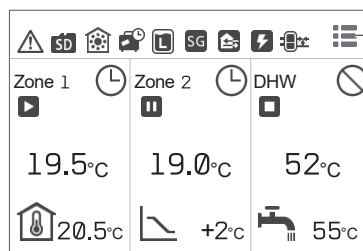

[Home screen]

Press and hold the icon for 3 seconds.

Lock

Lock menu

Pressing and holding the menu icon for 3 seconds switches the lock menu to on.

(The icon changes to when the lock menu is on.)

Some functions cannot be edited in this state.

Note: You need a password to edit [Service] even when the lock menu is off.

Refer to the main controller menu tree for details of the items which cannot be edited when the lock menu is on.

<Main Controller Menu Tree>

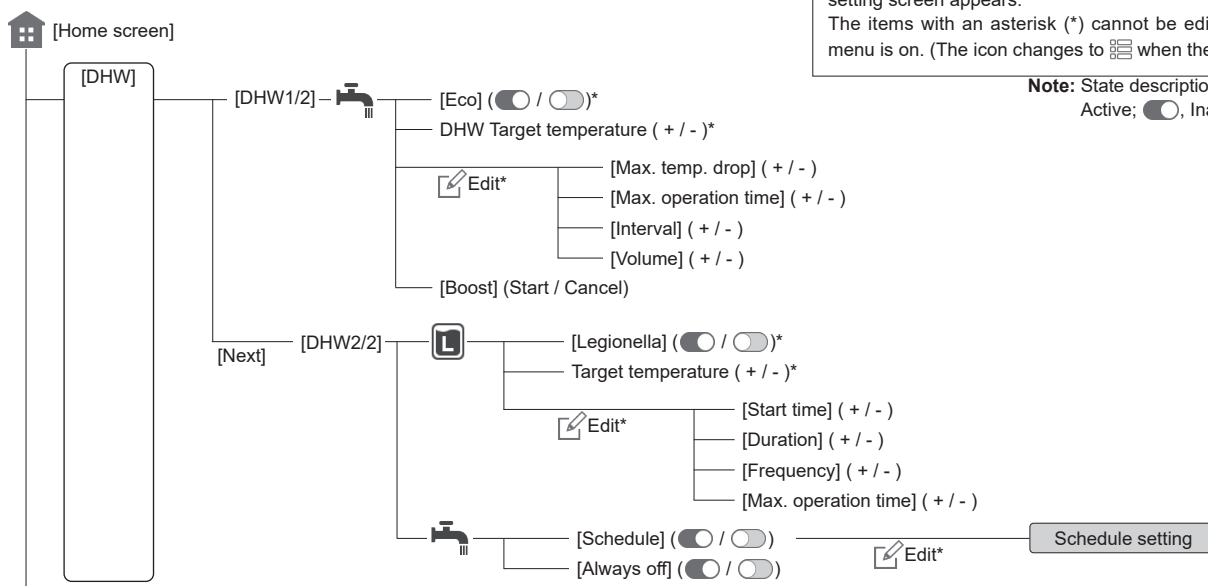

When the system is started up for the first time, the quick start setting screen appears. The items with an asterisk (*) cannot be edited when the lock menu is on. (The icon changes to when the lock menu is on.)

Note: State description indicated by toggle
Active: , Inactive:

6 Remote Controller

<Main Controller Menu Tree>

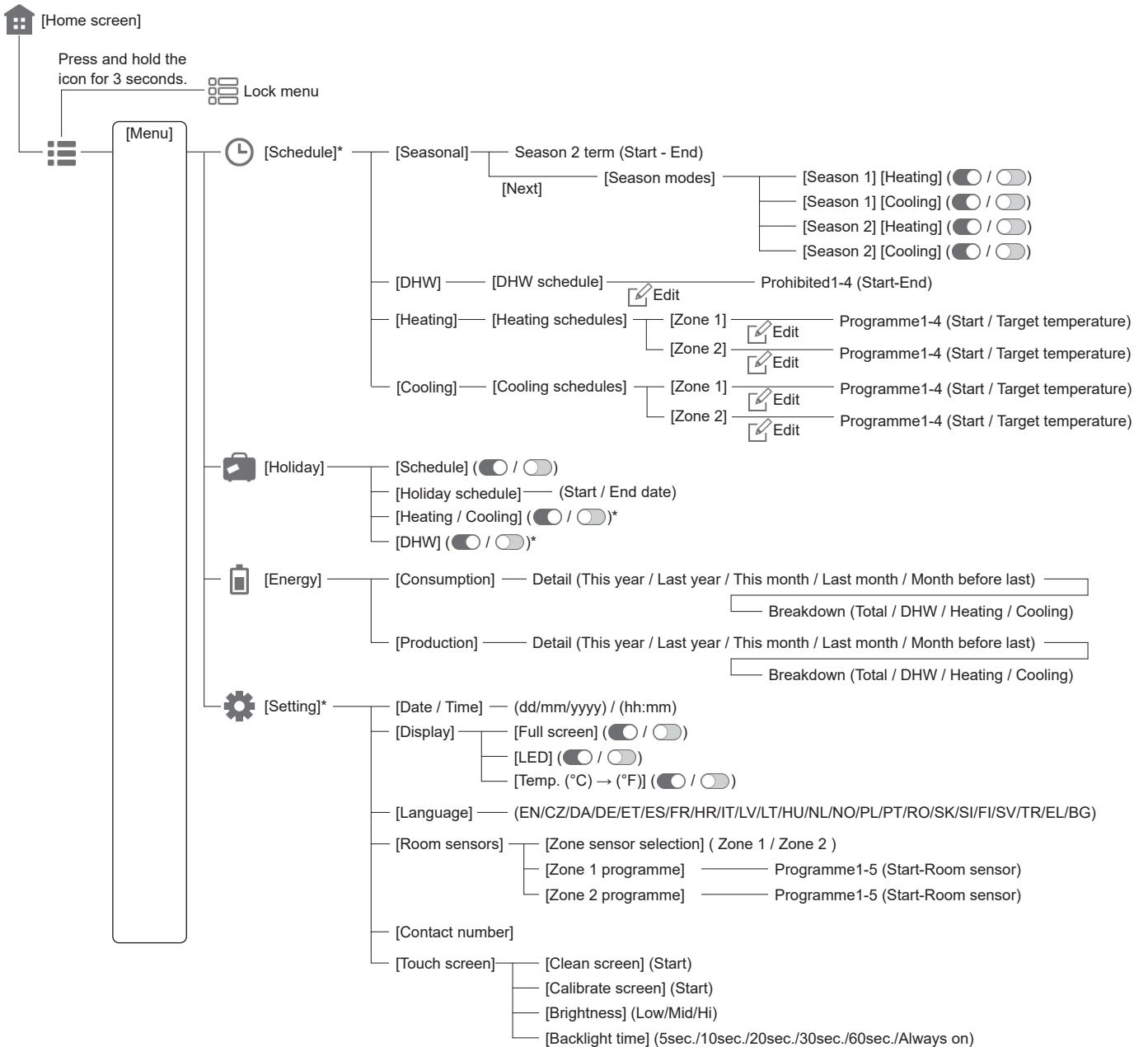
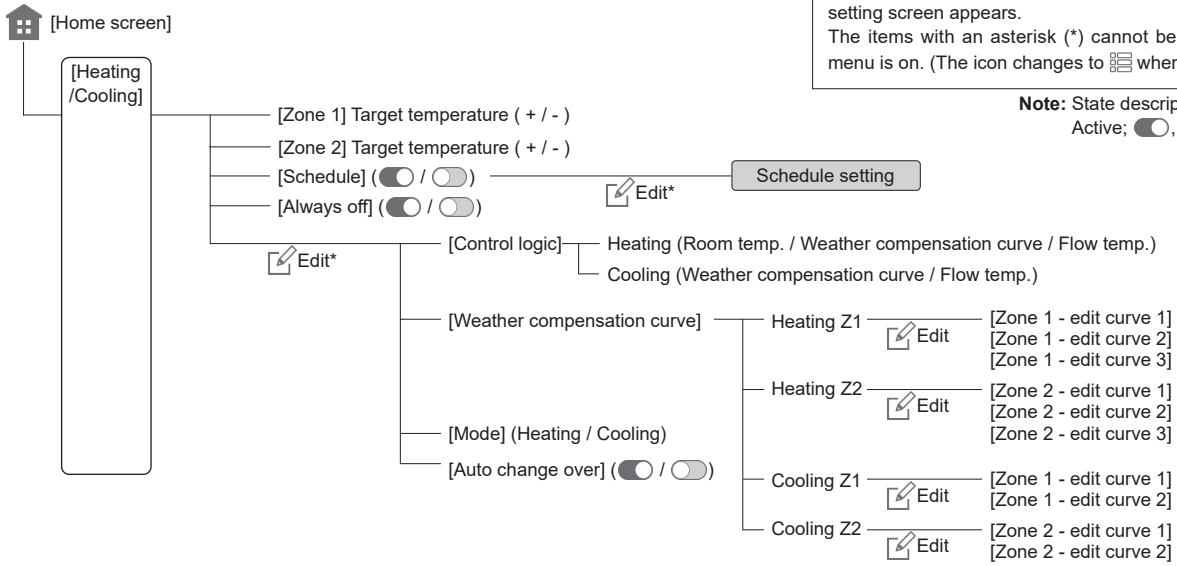

6 Remote Controller

Continued from the previous page.

<Main Controller Menu Tree>

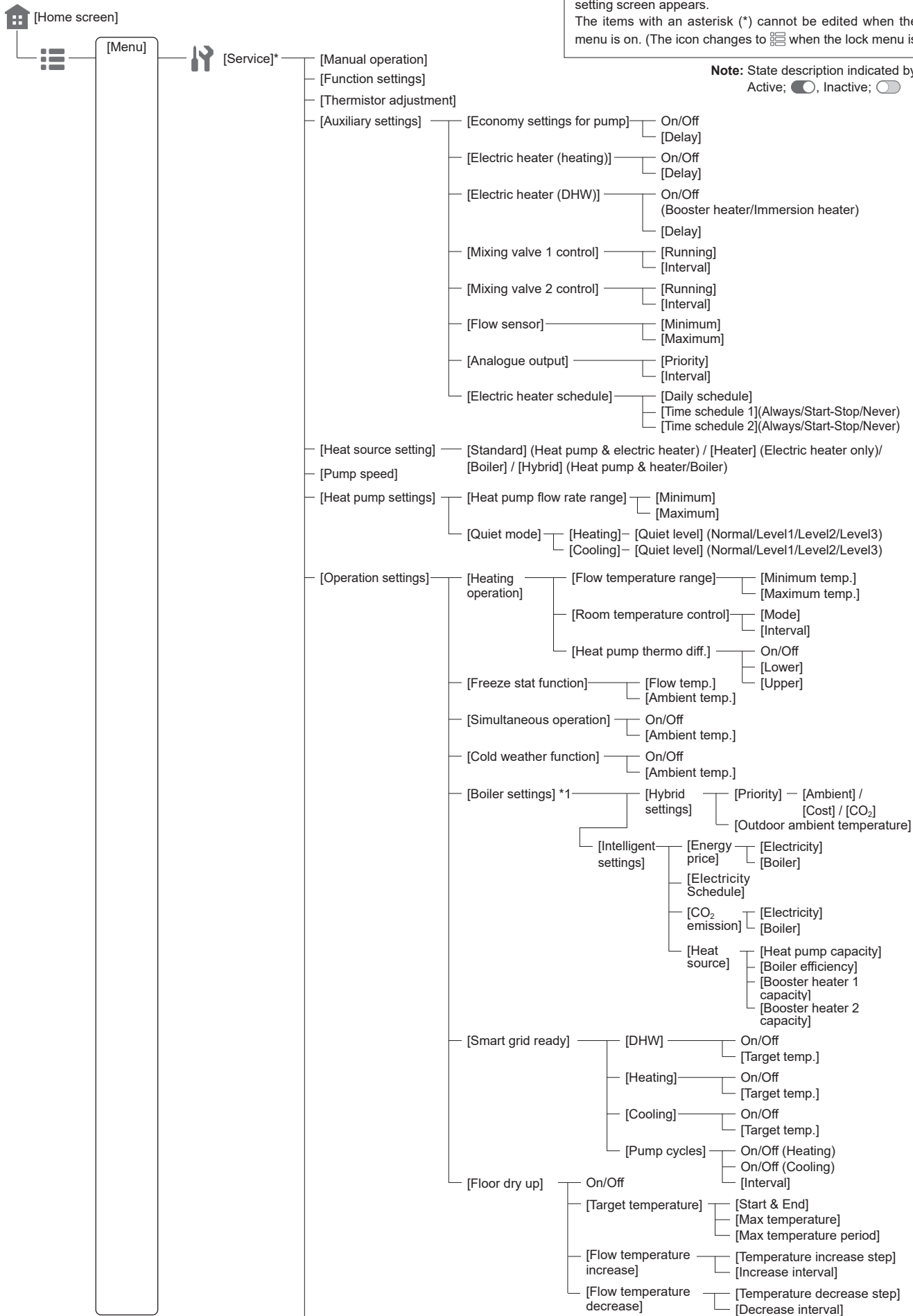

When the system is started up for the first time, the quick start setting screen appears.
The items with an asterisk (*) cannot be edited when the lock menu is on. (The icon changes to when the lock menu is on.)

Note: State description indicated by toggle
Active: , Inactive:

<Continued to next page.>

*1 For more details, refer to the installation manual of PAC-TH012HT(L)-E.

6 Remote Controller

Continued from the previous page.

<Main Controller Menu Tree>

When the system is started up for the first time, the quick start setting screen appears. The items with an asterisk (*) cannot be edited when the lock menu is on. (The icon changes to when the lock menu is on.)

• Note:
State description indicated by toggle
Active; , Inactive;

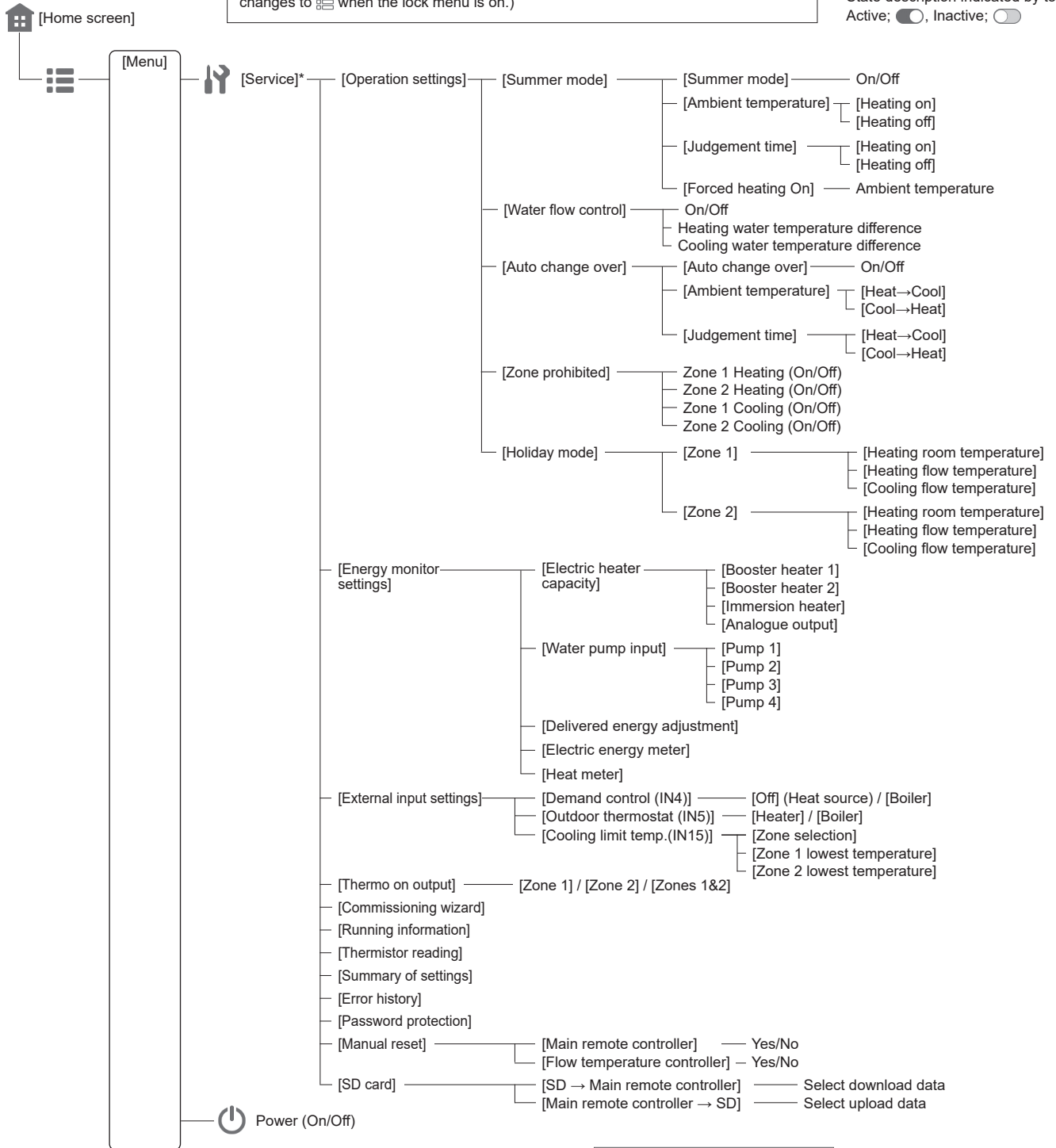

DHW (Domestic Hot Water) / Legionella Prevention

The DHW and legionella prevention menus control the operation of DHW tank heat ups.

DHW mode settings

- [DHW]: The Eco mode can be activated/deactivated by the toggle. The target temperature can be adjusted by +/-.
- From the edit icon , [Max. temp. drop], [Max. operation time], [Interval], and [Volume] can be set.

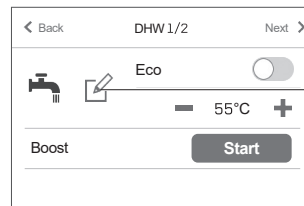

[DHW]

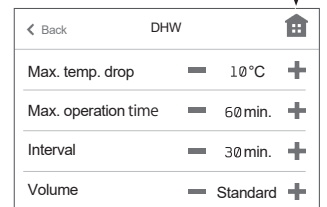

[DHW]

6 Remote Controller

Menu subtitle	Function	Range	Unit	Default value
DHW target temp.	Desired temperature of stored hot water	40 - 70*1	°C	50
[Max. temp. drop]	Difference in temperature between the DHW maximum temperature and the temperature at which DHW mode restarts	5 - 40*2	°C	10
[Max. operation time]	Maximum time allowed for stored water heating DHW mode	30 - 120	min.	60
[Interval]	The time period after DHW mode when space heating has priority over DHW mode temporarily preventing further stored water heating (Only when DHW max. operation time has passed.)	30 - 120	min.	30

*1 The maximum temperature differs depending on the connected outdoor unit. (60°C/65°C/70°C)

*2 When the DHW maximum temperature is set over 55°C, the temperature at which DHW mode restarts must be less than 50°C to protect the device.

[Eco]

DHW mode can run in either normal or Eco mode. Normal mode will heat the water in the DHW tank fast using the full power of the heat pump. Eco mode takes a little longer to heat the water in the DHW tank, but the energy used is reduced. This is because heat pump operation is restricted using signals from the FTC based on measured DHW tank temperature.

Note: The actual energy saved in Eco mode will vary according to outdoor ambient temperature.

[Volume]

Select the amount of DHW tank. If you need much hot water, select [Large].

Return to the DHW/legionella prevention menu.

Legionella prevention mode settings (LP mode)

- [Legionella]: It can be activated/deactivated by the toggle.
The target temperature can be changed by +/-.
From the edit icon , [Start time], [Duration], [Frequency], and [Max. operation time] can be set.
- [Schedule]: It can be activated/deactivated by the toggle.
- [Always off]: It can be activated/deactivated by the toggle.

During LP mode, the temperature of the stored water is increased above 60°C to inhibit legionella bacteria growth. It is strongly recommended that this is done at regular intervals. Please check local regulations for the recommended frequency of heat ups.

Note 1: When failures occur on the hydrobox, the LP mode may not function normally.

Note 2: Even when DHW operation is prohibited, LP mode will operate.

Please note that LP mode uses the assistance of electric heaters to supplement the energy input of the heat pump. Heating water for long periods of time is not efficient and will increase running costs. The installer should give careful consideration to the necessity of legionella prevention treatment whilst not wasting energy by heating the stored water for excessive time periods. The end user should understand the importance of this feature.
ALWAYS COMPLY WITH LOCAL AND NATIONAL GUIDANCE FOR YOUR COUNTRY REGARDING LEGIONELLA PREVENTION.

Menu subtitle	Function	Range	Unit	Default value
Hot water temp.	Desired temperature of stored hot water	60 - 70	°C	65
[Start time]	Time when LP mode will begin	0:00 - 23:00	-	03:00
[Duration]	The time period after LP mode desired water temperature has been reached	1 - 120	min.	30
[Frequency]	Time between LP mode DHW tank heat up	1 - 30	day	15
[Max. operation time]	Maximum time allowed for LP mode DHW tank heat	1 - 5	h	3

[Setting]

From the menu icon , access [Setting].

The following items can be edited in [Setting].

- [Date / time]
- [Display] (From [Setting], the screen can be switched to the full screen or the base screen.)
- [Language]
- [Room sensors]
- [Contact number]
- [Touch screen] ([Calibrate screen]*1, [Clean screen]*2, [Brightness], and [Backlight time])

Follow the procedure described in General Operation for the set up operation.

*1 Touching the 9 dots displayed on the screen starts calibration.

To properly calibrate the touch panel, use a pointy but not sharp object to touch the dots.

Note: A sharp object may damage or scratch the touch screen.

*2 You can wipe the screen while touch operations are invalid for 30 seconds.

Wipe with a soft dry cloth, a cloth soaked in water with mild detergent, or a cloth dampened with ethanol.

Do not use acidic, alkaline, or organic solvents.

[Room sensors]

For [Room sensors], it is important to choose the correct room sensor depending on the heating and cooling mode the system will operate in.

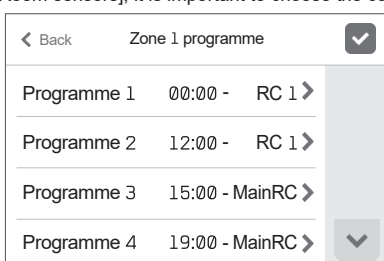

[Zone 1 programme]

6 Remote Controller

Menu subtitle	Description																	
[Zone sensor selection]	When 2-zone temperature control is active and wireless remote controllers are available, select [Zone sensor selection] in [Room sensors] from [Setting], and then select zone No. (Zone 1/Zone 2) to assign each remote controller.																	
[Zone 1 programme] [Zone 2 programme]	<p>From [Zone 1 programme] or [Zone 2 programme], select a wireless remote controller to be used for monitoring the room temperature from Zone 1 and Zone 2 separately.</p> <table border="1"> <thead> <tr> <th rowspan="2">Control option *</th> <th colspan="2">Corresponding initial settings room sensor</th> </tr> <tr> <th>[Zone 1]</th> <th>[Zone 2]</th> </tr> </thead> <tbody> <tr> <td>A Zone 1 ; Auto Adaptation (Target room temperature) Zone 2 ; Weather compensation curve or flow temperature control</td> <td>RC 1~8 (Wireless remote controller)</td> <td>*1</td> </tr> <tr> <td>B Zone 1 ; Auto Adaptation (Target room temperature) Zone 2 ; Weather compensation curve or flow temperature control</td> <td>TH1 (Room temperature thermistor (option))</td> <td>*1</td> </tr> <tr> <td>C Zone 1 ; Auto Adaptation (Target room temperature) Zone 2 ; Weather compensation curve or flow temperature control</td> <td>[MainRC] (Main remote controller)</td> <td>*1</td> </tr> <tr> <td>D Zone 1 ; Weather compensation curve or flow temperature control Zone 2 ; Weather compensation curve or flow temperature control</td> <td>*1</td> <td>*1</td> </tr> </tbody> </table> <p style="text-align: right;">* Refer to the website manual for details.</p> <p>*1. Not specified (if a locally-supplied room thermostat is used) RC 1-8 (if a wireless remote controller is used as a room thermostat) The wireless remote controller to be used can be changed up to 4 times within 24 hours according to the set time schedule. (Programme 1-5)</p>	Control option *	Corresponding initial settings room sensor		[Zone 1]	[Zone 2]	A Zone 1 ; Auto Adaptation (Target room temperature) Zone 2 ; Weather compensation curve or flow temperature control	RC 1~8 (Wireless remote controller)	*1	B Zone 1 ; Auto Adaptation (Target room temperature) Zone 2 ; Weather compensation curve or flow temperature control	TH1 (Room temperature thermistor (option))	*1	C Zone 1 ; Auto Adaptation (Target room temperature) Zone 2 ; Weather compensation curve or flow temperature control	[MainRC] (Main remote controller)	*1	D Zone 1 ; Weather compensation curve or flow temperature control Zone 2 ; Weather compensation curve or flow temperature control	*1	*1
Control option *	Corresponding initial settings room sensor																	
	[Zone 1]	[Zone 2]																
A Zone 1 ; Auto Adaptation (Target room temperature) Zone 2 ; Weather compensation curve or flow temperature control	RC 1~8 (Wireless remote controller)	*1																
B Zone 1 ; Auto Adaptation (Target room temperature) Zone 2 ; Weather compensation curve or flow temperature control	TH1 (Room temperature thermistor (option))	*1																
C Zone 1 ; Auto Adaptation (Target room temperature) Zone 2 ; Weather compensation curve or flow temperature control	[MainRC] (Main remote controller)	*1																
D Zone 1 ; Weather compensation curve or flow temperature control Zone 2 ; Weather compensation curve or flow temperature control	*1	*1																

[Service]

The service menu provides functions to be used by installer or service engineer. It is NOT intended for the home owner to alter settings within this menu. It is for this reason password protection is required to prevent unauthorised access to the service settings.

The factory default password is "0000".

Follow the procedure described in [Password protection] for the set up operation.

Many functions can not be set whilst the indoor unit is running. The installer should turn off the unit before trying to set these functions. If the installer attempts to change the settings whilst the unit is running, the main remote controller will display a reminder message prompting the installer to stop operation before continuing. By selecting "Yes", the unit will cease operation.

[Manual operation]

During the filling of the system, the primary circuit circulation pump, 3-way valve and mixing valve can be manually overridden using manual operation mode.

When manual operation is selected, a small timer icon appears in the screen. When selected, this function will only remain in manual operation for a maximum of 2 hours. This is to prevent accidental permanent override of the FTC.

Manual operation and heat source setting can not be selected if the system is running. A screen will be displayed asking the installer to stop the system before these modes can be activated.
The system automatically stops 2 hours after last operation.

[Floor dry up function]

The floor dry up function automatically changes the target hot water temperature in stages to gradually dry concrete when this particular type of underfloor heating system is installed.

Upon completion of the operation, the system stops all the operations except the Freeze stat. operation.

For floor dry up function, the target flow temperature of Zone 1 is the same as that of Zone 2.

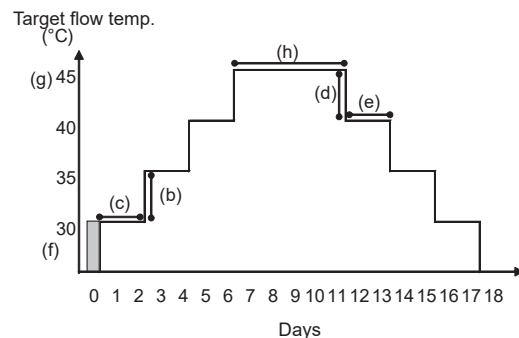

- This function is not available when a PUAZ-FRP outdoor unit is connected.
- Disconnect wiring to external inputs of room thermostat, demand control, and outdoor thermostat, or the target flow temperature may not be maintained.

6 Remote Controller

Functions	Symbol	Description	Option/Range	Unit	Default
[Floor dry up function]	a	Set the function to on and power on the system using the main remote controller, and the dry up heating operation will start.	on/off	—	off
[Flow temperature increase]	b	It sets the increase step of the target flow temperature.	+1 to +30	°C	+5
	c	It sets the period for which the same target flow temperature is maintained.	1 to 7	day	2
[Flow temperature decrease]	d	It sets the decrease step of the target flow temperature.	-1 to -30	°C	-5
	e	It sets the period for which the same target flow temperature is maintained.	1 to 7	day	2
[Target temperature]	f	It sets the target flow temperature at the start and the finish of the operation.	20 to 60*	°C	30
	g	It sets the maximum target flow temperature.	20 to 60*	°C	45
	h	It sets the period for which the maximum target flow temperature is maintained.	1 to 20	day	5

* The maximum temperature differs depending on the connected outdoor unit.

[Password protection]

Password protection is recommended to prevent unauthorised access to the service menu by untrained persons.

[Password reset]

If you forget the password you entered, or have to service a unit somebody else installed, you can reset and change the password.

1. From [Service] in [Menu], access the [Password protection] screen.
2. Press and hold the title section for 3 seconds to access the [Password reset] screen.
3. Enter a new password.
4. Touching [Back] or the confirm icon saves the password.

[Manual reset]

Should you wish to restore the factory settings at any time, you should use the manual reset function. Please note this will reset ALL functions to the factory default settings.

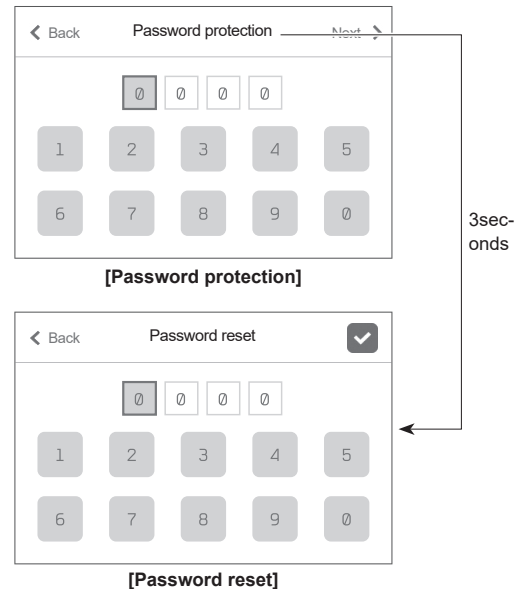

7 Commissioning

■ Pre-commissioning exercises- potable/DHW circuit (ONLY cylinder unit or DHW system)

Initial fill procedure:

Ensure all pipe joints and fittings are tight and secure.

Open the most distant DHW tap/outlet.

Slowly/gradually open the main water supply to begin filling unit and DHW pipework.

Allow most distant tap to run free and release/purge residual air from installation.

Close tap/outlet to retain fully charged system.

Note: When an immersion heater is fitted, do NOT energise the heater until the DHW tank is full of water. Also do NOT energise any immersion heater if any sterilisation chemicals remain in the DHW tank as this will cause premature failure of the heater.

Initial flush procedure:

Energise system to heat-up indoor unit contents to a temperature of approx. 30 - 40°C.

Flush/drain the water contents to remove any residue/impurities resulting from the installation works. Use the cylinder unit drain cock to safely discharge the warmed water to drain via a suitable hose.

On completion, close drain cock, re-fill system and resume system commissioning.

8 Service and Maintenance

The indoor unit must be serviced once a year by a qualified individual. Service and maintenance of the outdoor unit should only be done by a Mitsubishi Electric trained technician with relevant qualifications and experience. Any electrical work should be done by a personnel with the appropriate electrical qualifications. Any maintenance or 'DIY' fixes done by a non-accredited person could invalidate the Warranty and/or result in damage to the hydrobox/cylinder unit and injury to the person.

■ Error Codes

Code	Error	Action
L3	Circulation water temperature overheat protection	Flow rate may be reduced. Check for; <ul style="list-style-type: none"> • Water leakage • Magnetic filter / Strainer blockage • Water circulation pump function (Error code may display during filling of primary circuit, complete filling and reset error code.)
L4	DHW tank water temperature overheat protection	Check the immersion heater and it's contactor.
L5	Indoor unit temperature thermistor (THW1, THW2, THW5A, THW5B, THW6, THW7, THW8, THW9) failure	Check resistance across the thermistor.
L6	Circulation water freeze protection	See Action for L3.
L8	Heating operation error	Check and re-attach any thermistors that may have become dislodged.
L9	Low primary circuit flow rate detected by flow sensor or flow switch (flow switches 1, 2, 3)	See Action for L3. If the flow sensor or flow switch itself does not work, replace it. Caution: The pump valves may be hot, please take care.
LA	Pressure sensor failure	Check pressure sensor cable for damage or loose connections.
LB	High pressure protection	<ul style="list-style-type: none"> • Flow rate of the heating circuit may be reduced. Check water circuit. • Plate heat exchanger may be clogged. Check the plate heat exchanger. • Outdoor unit failure. Check refrigerant volume, valve, LEV coil and pipe crushing of outdoor unit.
LC	Boiler circulation water temperature overheat protection	Check if the setting temperature of the Boiler for heating exceeds the restriction. (See the manual of the thermistors "PAC-TH012HT(L)-E")
		Flow rate of the heating circuit from the boiler may be reduced. Check for <ul style="list-style-type: none"> • Water leakage • Magnetic filter / Strainer blockage • Water circulation pump function.
LD	Thermistor (Boiler flow water temp.) (THWB1) failure	Check resistance across the thermistor.
LE	Boiler operation error	See Action for L8. Check the status of the boiler.
LF	Flow sensor failure	Check flow sensor cable for damage or loose connections.
LH	Boiler circulation water freeze protection	Flow rate of the heating circuit from the boiler may be reduced. Check for <ul style="list-style-type: none"> • Water leakage • Magnetic filter / Strainer blockage • Water circulation pump function.
LJ	DHW operation error (type of external plate HEX)	<ul style="list-style-type: none"> • Check for disconnection of the thermistor (DHW tank lower water temp.) (THW5B). • Flow rate may be reduced. Check for water circulation pump function. (primary / sanitary)
LL	Setting errors of DIP switches on FTC control board	For boiler operation, check that DIP SW1-1 is set to ON (With Boiler) and DIP SW2-6 is set to ON (With Mixing Tank). For 2-zone temperature control, check DIP SW2-7 is set to ON (2-zone) and DIP SW2-6 is set to ON (With Mixing Tank).
LP	Out of water flow rate range for outdoor heat pump unit	Check the installation the water flow rate range (Table 4.3.1). Check remote controller settings ([Service] → [Heat pump settings] → [Heat pump flow rate range]) See Action for L3.
P1	Thermistor (Room temp.) (TH1) failure	Check resistance across the thermistor.
P2	Thermistor (Ref. liquid temp.) (TH2) failure	Check resistance across the thermistor.
P6	Anti-freeze protection of plate heat exchanger	See Action for L3. Check for correct amount of refrigerant.
J0	Communication failure between FTC and wireless receiver	Check connection cable for damage or loose connections.
J1 - J8	Communication failure between wireless receiver and wireless remote controller	Check wireless remote controller's battery is not flat. Check the pairing between wireless receiver to wireless remote controller. Test the wireless communication. (See the manual of wireless system)
E0 - E5	Communication failure between main remote controller and FTC	Check connection cable for damage or loose connections.
E6 - EF	Communication failure between FTC and outdoor unit	Check that the outdoor unit has not been turned off. Check connection cable for damage or loose connections. Refer to outdoor unit service manual.
E9	Outdoor unit receives no signal from indoor unit.	Check both units are switched on. Check connection cable for damage or loose connections. Refer to outdoor unit service manual.
EE	Combination error between FTC and outdoor unit	Check combination of FTC and outdoor unit.
U*, F*	Outdoor unit failure	Refer to outdoor unit service manual.
A*	M-NET communication error	Refer to outdoor unit service manual.

Note: To cancel error codes, please switch system off (Touch [Reset] on main remote controller).

en

8 Service and Maintenance

■ Annual Maintenance (cylinder unit and hydrobox)

It is essential that the indoor unit is serviced at least once a year by a qualified individual. Any required parts should be purchased from Mitsubishi Electric. NEVER bypass safety devices or operate the unit without them being fully operational. For more details, refer to service handbook.

Notes

- Within the first couple of months of installation, remove and clean the indoor unit's strainer plus any additional filter items that are fitted external to the indoor unit. This is especially important when installing on an old/existing pipe work system.
- The pressure relief valve and T&P valve should be checked annually by turning the knob manually so that the medium is discharged, thus cleaning the seal seat.

In addition to annual servicing it is necessary to replace or inspect some parts after a certain period of system operation. Please see tables below for detailed instructions. Replacement and inspection of parts should always be done by a competent person with relevant training and qualifications.

Parts which require regular replacement

Parts	Replace every	Possible failures
Pressure relief valve (PRV) Manometer Inlet control group (ICG)*1 Mud trap*2	6 years	Water leakage

*1 OPTIONAL PARTS for UK

*2 Cylinder unit: ERST17D-*M*BE

Parts which require regular inspection

Parts	Check every	Possible failures
Pressure relief valve (3bar) Temperature and pressure relief valve	1 year (turning the knob manually)	It could seize and risk burst of expansion vessel
Immersion heater*3	2 years	Earth leakage causing circuit breaker to activate (Heater is always OFF)
Water circulation pump (Primary circuit)	20,000 hrs (3 years)	Water circulation pump failure
Magnetic filter	3 years	Flow rate decrease due to clogging
Mud trap*4	1 year	Flow rate decrease due to clogging

*3 Cylinder unit: EHPT20X-MEHEW and OPTIONAL PART

*4 Cylinder unit: ERST17D-*M*BE

Parts which must NOT be re-used when servicing

- * O-ring
- * Gasket

Note:

- Always replace the gasket for pump with a new one at each regular maintenance (every 20,000 hours of use or every 3 years).

<Draining particles from the magnetic filter>

Note: DRAINED WATER MAY BE VERY HOT

1. Turn OFF the unit via the user interface.
2. Turn OFF the circuit breaker.
3. Check if body of the magnet filter is still fitted tight (a).
4. Close the isolating valves.
5. Put a suitable bottle below the magnetic filter.
6. Remove fastener and open the cap of the filter (b).
7. Collect the water and particles in the bottle.
8. Wash the inside mesh and magnet and remove particles from them.
9. Put the inside mesh and magnet back into the filter.
10. Fit the cap with fastener.
11. Open the isolating valves.
12. Check the pressure of the water circuit.

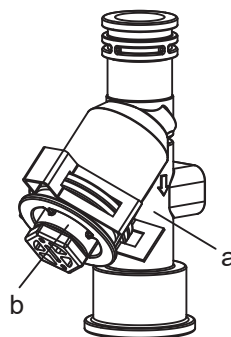

a. body
b. cap

<Draining particles from the magnetic filter (ONLY Cylinder unit: ERST17D-*M*BE)>

Note: DRAINED WATER MAY BE VERY HOT

1. Turn OFF the unit via the user interface.
2. Turn OFF the circuit breaker.
3. Check if body of the magnet filter is still screwed tight (a).
4. Close the isolating valves.
5. Hold the motor of mixing valve and pull hard to remove it from the valve.
6. Put a suitable bottle below the magnetic filter.
7. Open the cap of the filter with 2 spanners (b).
8. Collect the water and particles in the bottle.
9. Wash the inside mesh and magnet and remove particles from them.
10. Put the inside mesh and magnet back into the filter.
11. Screw the cap with 2 spanners.
12. Reattach the motor on the mixing valve.
13. Open the isolating valves.
14. Check the pressure of the water circuit.

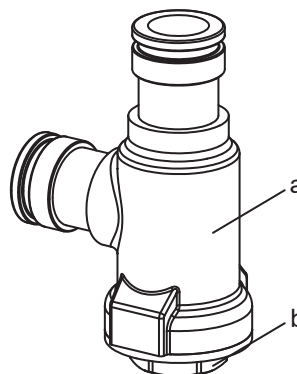

a. body
b. cap

8 Service and Maintenance

<Draining dirt from the mud trap (ONLY Cylinder unit: ERST17D-*M*BE)>

Note: DRAINED WATER MAY BE VERY HOT

1. Turn OFF the unit via the user interface.
2. Turn OFF the circuit breaker.
3. Check if upper and lower parts of the mud trap are still screwed tight (a, c).
4. Take off the magnetic sleeve (b).
5. Unscrew the drain cap (e).
6. Connect a drain hose to the bottom of the mud trap so that the water and dirt can be collected in a suitable bottle.
7. Open the drain valve for a couple of seconds (d).
8. After dirt drained, close the drain valve.
9. Screw the drain cap back on.
10. Reattach the magnetic sleeve.
11. Check the pressure of the water circuit.

Notes:

- When checking the mud trap for tightness, hold it firmly, so as NOT to apply stress to the water piping.
- To prevent dirt from remaining in the mud trap, take off the magnetic sleeve.
- Always first unscrew the drain cap, and connect a drain hose to the bottom of the water filter, then open the drain valve.

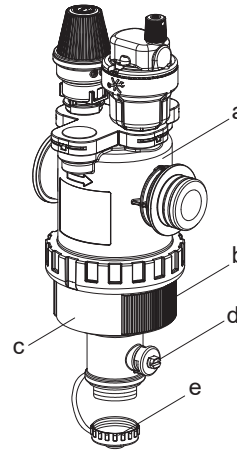

- a upper part
- b magnetic sleeve
- c lower part
- d drain valve
- e drain cap

8 Service and Maintenance

Engineers Forms

Should settings be changed from default, please enter and record new setting in 'Commissioning/Field settings record sheet' below. This will ease resetting in the future should the system use change or the circuit board need to be replaced.

Commissioning/Field settings record sheet

Main remote controller screen			Parameters	Default setting	Field setting	Notes	
DHW	DHW *4	Eco	On/Off *5	Off			
		Boost	On/Off	—			
		DHW max. temp.	40°C to 55/60/65/70°C *6	50°C			
		Max. temp. drop	5°C to 40°C	10°C			
		Max. operation time	30 to 120 min.	60 min.			
		Interval	30 to 120 min.	30 min.			
		Volume	Large / Standard	Standard *7			
		Schedule	On/Off	Off			
		Always off	On/Off	Off			
		Legionella prevention *4	Legionella	On/Off	On		
		Hot water temp.	60°C to 70°C *6	65°C			
		Start time	00:00 to 23:00	03:00			
		Duration	1 to 120 min.	30 min.			
		Frequency	1 to 30 days	15 days			
		Max. operation time	1 to 5 h	3 h			
	Heating / Cooling *3	Heating / Cooling	Zone 1 heating room temp.	10°C to 30°C	20°C		
			Zone 2 heating room temp. *1	10°C to 30°C	20°C		
			Zone 1 heating flow temp.	20°C to 60/70/75°C	45°C		
			Zone 2 heating flow temp. *2	20°C to 60/70/75°C	35°C		
Zone 1 cooling flow temp. *3			5°C to 25°C	15°C			
Zone 2 cooling flow temp. *3			5°C to 25°C	20°C			
Zone 1 heating weather compensation curve			-9°C to +9°C	0°C			
Zone 2 heating weather compensation curve *2			-9°C to +9°C	0°C			
Zone 1 cooling weather compensation curve			-9°C to +9°C	0°C			
Zone 2 cooling weather compensation curve *2			-9°C to +9°C	0°C			
Schedule			On/Off	Off			
Always off			On/Off	Off			
Heating / Cooling			Heating / Cooling	Heating			
Zone 1 control logic			Heating room temp./ Heating flow temp./ Heating weather compensation curve / Cooling flow temp./ Cooling weather compensation curve	Heating weather compensation curve			
Zone 2 control logic *2		Heating room temp./ Heating flow temp./ Heating weather compensation curve / Cooling flow temp./ Cooling weather compensation curve	Heating weather compensation curve				
Auto change over		On/Off	Off				
Weather compensation curve (Heating)		Hi flow temp. set point	Zone 1 outdoor ambient temp.	-30°C to +33°C *8	-15°C		
			Zone 1 flow temp.	20°C to 60/70/75°C	50°C		
			Zone 2 outdoor ambient temp. *2	-30°C to +33°C *8	-15°C		
			Zone 2 flow temp. *2	20°C to 60/70/75°C	40°C		
		Lo flow temp. set point	Zone 1 outdoor ambient temp.	-28°C to +35°C *9	20°C		
			Zone 1 flow temp.	20°C to 60/70/75°C	25°C		
			Zone 2 outdoor ambient temp. *2	-28°C to +35°C *9	20°C		
			Zone 2 flow temp. *2	20°C to 60/70/75°C	25°C		
		Adjust	Zone 1 outdoor ambient temp.	-29°C to +34°C *10	—		
			Zone 1 flow temp.	20°C to 60/70/75°C	—		
			Zone 2 outdoor ambient temp. *2	-29°C to +34°C *10	—		
			Zone 2 flow temp. *2	20°C to 60/70/75°C	—		
Weather compensation curve (Cooling)		Hi flow temp. set point	Zone 1 outdoor ambient temp.	10°C to 46°C	35°C		
			Zone 1 flow temp.	5°C to 25°C	15°C		
	Zone 2 outdoor ambient temp. *2		10°C to 46°C	35°C			
	Zone 2 flow temp. *2		5°C to 25°C	20°C			
	Lo flow temp. set point	Zone 1 outdoor ambient temp.	10°C to 46°C	25°C			
		Zone 1 flow temp.	5°C to 25°C	25°C			
		Zone 2 outdoor ambient temp. *2	10°C to 46°C	25°C			
		Zone 2 flow temp. *2	5°C to 25°C	25°C			
Menu	Energy	Energy monitor	Consumed electrical energy/Delivered energy	—			
		Holiday	Schedule	On/Off/Set time	—		
	Setting	Language	DHW *4	On/Off	Off		
			Heating / Cooling *3	On/Off	On		
		Room sensors	Language	EN/CZ/DA/DE/ET/ES/FR/HR/IT/LV/LT/HU/NL/NO/PL/PT/RO/SK/SI/FI/SV/TR/EL/BG	EN		
			Zone sensor selection *2	Zone 1/Zone 2	Zone 1		
		Display	Zone 1 programme	TH1/Main RC/Room RC1-8/"Time/Zone"	TH1		
			Zone 2 programme *2	TH1/Main RC/Room RC1-8/"Time/Zone"	TH1		
		Touch screen	Temp. (°C) → (°F)	On/Off	Off		
			Clean screen	On/Off	Off		
Calibrate screen	On/Off		Off				
Brightness	Low / Mid / Hi		Mid				
Backlight time	5sec./10sec./20sec./30sec./60sec./Always on	30sec.					

Continued to next page.

8 Service and Maintenance

■ Engineers Forms

Commissioning/Field settings record sheet

Main remote controller screen			Parameters	Default setting	Field setting	Notes			
Menu	Service	Thermistor adjustment	THW1	-10°C to +10°C	0°C				
			THW2	-10°C to +10°C	0°C				
			THW5B	-10°C to +10°C	0°C				
			THW6	-10°C to +10°C	0°C				
			THW7	-10°C to +10°C	0°C				
			THW8	-10°C to +10°C	0°C				
			THW9	-10°C to +10°C	0°C				
			THW10	-10°C to +10°C	0°C				
			THWB1	-10°C to +10°C	0°C				
			Auxiliary settings	Economy settings for pump.	On/Off *11	On			
		Delay (3 to 60 min.)			10 min.				
		Electric heater (heating)		Space heating: On (used)/Off (not used)	On				
				Electric heater delay timer (5 to 180 min.)	30 min.				
		Electric heater (DHW) *4		Booster heater	DHW: On (used)/Off (not used)	On			
				Immersion heater	DHW: On (used)/Off (not used)	On			
				Electric heater delay timer (15 to 30 min.)	15 min.				
		Mixing valve 1 control		Running (10 to 240 sec.)	120 sec.				
				Interval (1 to 30 min.)	2 min.				
		Mixing valve 2 control		Running (10 to 240 sec.)	120 sec.				
				Interval (1 to 30 min.)	2 min.				
		Flow sensor *12		Minimum (0 to 100 L/min)	5 L/min				
				Maximum (0 to 100 L/min)	100 L/min				
		Analogue output		Interval (1 to 30 min.)	5 min.				
				Priority (Normal / High)	Normal				
		Electric heater schedule *19	Daily schedule (Schedule 1/Schedule 2)	Schedule 1					
			Time schedule 1 (Always/Start-Stop/Never)	Always					
			Time schedule 2 (Always/Start-Stop/Never)	Always					
		Pump speed	DHW	Pump speed (1 to 5)	5				
			Heating / Cooling	Pump speed (1 to 5)	5				
		Heat source setting		Standard / Heater / Boiler / Hybrid *13	Standard				
		Heat pump settings	Heat pump flow rate range	Minimum (0 to 100 L/min)	5 L/min				
				Maximum (0 to 100 L/min)	100 L/min				
			Quiet mode	Heating	Day (Mon to Sun)	—			
					Time	0:00 to 23:45			
				Cooling	Quiet level (Normal/ Level1/ Level2/ Level3)	Normal			
					Day (Mon to Sun)	—			
				Time	0:00 to 23:45				
				Quiet level (Normal/ Level1/ Level2/ Level3)	Normal				
			Operation settings	Heating operation	Flow temperature range *14	Minimum temp. (20 to 45°C)	30°C		
						Maximum temp. (35 to 60/70/75°C)	50°C		
		Room temperature control *14			Mode (Auto/Quick/Normal/Slow)	Auto			
					Interval (10 to 60 min.)*15	10 min.			
		Heat pump thermo diff.			On/Off *11	On			
				Lower (-9 to -1°C)	-5°C				
				Upper (+3 to +5°C)	5°C				
		Freeze stat function *16		Ambient temp. (3 to 20°C) / **	5°C				
		Simultaneous operation (DHW/ Heating)		On/Off *11	Off				
				Ambient temp. (-30 to +10°C) *8	-15°C				
		Cold weather function		On/Off *11	Off				
				Ambient temp. (-30 to -10°C) *8	-15°C				
		Boiler settings		Hybrid settings	Outdoor ambient temp. (-30 to +10°C) *8	-15°C			
					Priority mode (Ambient/Cost/CO ₂) *17	Ambient			
					Outdoor ambient temp. rise (+1 to +5°C)	+3°C			
			Intelligent settings	Energy price *18	Electricity (0.001 to 999 */kWh)	0.5 */kWh			
					Boiler (0.001 to 999 */kWh)	0.5 */kWh			
				CO ₂ emission	Electricity (0.001 to 999 kg -CO ₂ /kWh)	0.5 kg -CO ₂ /kWh			
					Boiler (0.001 to 999 kg -CO ₂ /kWh)	0.5 kg -CO ₂ /kWh			
				Heat source	Heat pump capacity (1 to 40 kW)	11.2 kW			
					Boiler efficiency (25 to 150%)	80%			
			Booster heater 1 capacity (0 to 30 kW)	2 kW					
			Booster heater 2 capacity (0 to 30 kW)	4 kW					

en

Continued to next page.

■ Engineers Forms

Commissioning/Field settings record sheet (continued from the previous page)

Main remote controller screen				Parameters		Default setting	Field setting	Notes
Menu	Service	Operation settings						
en			Smart grid ready	DHW	On/Off		Off	
					Target temp. (+1 to +30°C) / -- (Non active)		--	
				Heating	On/Off		Off	
					Target temp.	Switch-on recommendation (20 to 60/70/75°C)	50°C	
						Switch-on command (20 to 60/70/75°C)	55°C	
				Cooling	On/Off		Off	
					Target temp.	Switch-on recommendation (5 to 25°C)	15°C	
						Switch-on command (5 to 25°C)	10°C	
				Pump cycles	Heating (On/Off)		On	
					Cooling (On/Off)		On	
					Interval (10 to 120 min.)		10 min.	
				Floor dry up	On/Off *11		Off	
			Target temperature		Start & End (20 to 60/70/75°C)	30°C		
					Max temperature (20 to 60/70/75°C)	45°C		
					Max temperature period (1 to 20 days)	5 days		
			Flow temperature increase		Temperature increase step (+1 to +30°C)	+5°C		
					Increase interval (1 to 7 days)	2 days		
			Flow temperature decrease		Temperature decrease step (-1 to -30°C)	-5°C		
					Decrease interval (1 to 7 days)	2 days		
			Summer mode		On/Off		Off	
					Ambient temperature	Heating on (4 to 19°C)	10°C	
						Heating off (5 to 20°C)	15°C	
					Judgement time	Heating on (1 to 48 h)	6 h	
				Heating off (1 to 48 h)		6 h		
			Forced heating On (-30 to 10°C)	5°C				
			Auto change over	On/Off		Off		
				Ambient temperature	Heat→Cool (10 to 40°C)	28°C		
					Cool→Heat (5 to 20°C)	15°C		
				Judgement time	Heat→Cool (1 to 48 h)	6 h		
			Cool→Heat (1 to 48 h)		6 h			
			Water flow control	On/Off		Off		
				Water temperature difference *20	Heating (+3 to +20°C)	+5°C		
					Cooling (+3 to +10°C)	+5°C		
			Holiday mode	Zone 1 heating room temp.	10°C to 30°C	15°C		
				Zone 2 heating room temp. *1	10°C to 30°C	15°C		
				Zone 1 heating flow temp.	20°C to 60/70/75°C	35°C		
				Zone 2 heating flow temp. *2	20°C to 60/70/75°C	25°C		
				Zone 1 cooling flow temp. *3	5°C to 25°C	25°C		
				Zone 2 cooling flow temp. *3	5°C to 25°C	25°C		
				Zone prohibited				
			Heating (Zone 1)	Permitted/Prohibited	Permitted			
			Heating (Zone 2)	Permitted/Prohibited	Permitted			
Cooling (Zone 1)	Permitted/Prohibited	Permitted						
Cooling (Zone 2)	Permitted/Prohibited	Permitted						

Continued to next page.

8 Service and Maintenance

■ Engineers Forms

Commissioning/Field settings record sheet (continued from the previous page)

Main remote controller screen				Parameters	Default setting	Field setting	Notes
Menu	Service	Energy monitor settings	Electric heater capacity	Booster heater 1	0 to 30 kW	2 kW	
				Booster heater 2	0 to 30 kW	4 kW	
				Immersion heater	0 to 30 kW	0 kW	
				Analogue output	0 to 30 kW	0 kW	
			Delivered energy adjustment	-50 to +50%	0%		
			Water pump input	Pump 1	0 to 200 W or *** (factory fitted pump)	***	
				Pump 2	0 to 200 W	0 W	
				Pump 3	0 to 200 W	0 W	
				Pump 4 *7	0 to 200 W	72 W	
			Electric energy meter	0.1/1/10/100/1000 pulse/kWh	1000 pulse/kWh		
		Heat meter	0.1/1/10/100/1000 pulse/kWh	1000 pulse/kWh			
		External input settings	Demand control (IN4)	Heat source OFF/Boiler operation	Boiler operation		
			Outdoor thermostat (IN5)	Heater operation/Boiler operation	Boiler operation		
			Cooling limit temp. (IN15)	Zone selection	Zone 1/Zone 2/Zone 1&2	Zone 1	
				Zone 1 lowest temperature	5°C to 25°C	18°C	
				Zone 2 lowest temperature	5°C to 25°C	18°C	
			Thermo on output	Zone 1/Zone 2/Zone 1&2	Zone 1&2		

*1 The settings related to Zone 2 can be switched only when 2-zone temperature control or 2-zone valve ON/OFF control is active.

*2 The settings related to Zone 2 can be switched only when 2-zone temperature control is enabled (when DIP SW 2-6 and SW 2-7 are ON).

3 Cooling mode settings are available for ERS model only.

*4 Only available if DHW tank is present in system.

*5 When the indoor unit is connected with a PUMY-P outdoor unit, the mode is fixed to "Off".

*6 For the model without both booster and immersion heater, it may not reach the set temperature depending on the outside ambient temperature.

*7 This setting is valid for only cylinder units.

*8 The lower limit is -15°C depending on the connected outdoor unit.

*9 The lower limit is -13°C depending on the connected outdoor unit.

*10 The lower limit is -14°C depending on the connected outdoor unit.

*11 On: the function is active; Off: the function is inactive.

*12 Do not change the setting since it is set according to the specification of flow sensor attached to the indoor unit.

*13 When DIP SW1-1 is set to OFF "WITHOUT Boiler" or SW2-6 is set to OFF "WITHOUT Mixing tank", neither Boiler nor Hybrid can be selected.

*14 Valid only when operating in Heating room temperature.

*15 When DIP SW5-2 is set to OFF, the function is active.

*16 If asterisk (***) is chosen freeze stat function is deactivated. (i.e. primary water freeze risk)

*17 When the indoor unit is connected with a PUMY-P and PXZ outdoor unit, the mode is fixed to "Ambient".

*18 *** of **/kWh represents currency unit (e.g. €, £, or the like)

*19 Valid only during heating mode

*20 To enable this function in the outdoor unit of PUZ-S(H)WM, switch the [Mode 7] in [Function settings] to "2".

([Menu] → [Service] → [Function settings], [Ref. add: 0], [Unit: 1] → [Mode 7], 1-High temperature control (default) / 2-Water temperature difference control)

en

EU DECLARATION OF CONFORMITY
EU-KONFORMITÄTSEKHLÄRUNG
DECLARATION DE CONFORMITÉ UE
EU-CONFORMITEITSEVERKLARING
DECLARACIÓN DE CONFORMIDAD UE
DICHIARAZIONE DI CONFORMITÀ UE
ΔΗΛΩΣΗ ΣΥΜΜΟΡΦΩΣΗΣ ΕΕ
DECLARAÇÃO DE CONFORMIDADE UE

EU-OVERENSSTEMMELSESEKHLÆRING
EG-DEKLARATION OM ÖVERENSSTÄMMELSE
ЕС ДЕКЛАРАЦИЯ ЗА СЪОТВЕТСТВИЕ
DEKLARACJA ZGODNOŚCI UE
EU-ERKLÆRING OM SAMSVAR
EU-VAATIMUSTENMUKAISUUSVAKUUTUS
EU PROHLÁŠENÍ O SHODĚ
EU VYHLÁŠENIE O ZHODE

EU MEGFELELŐSÉGI NYILATKOZAT
IZJAVA EU O SKLADNOSTI
DECLARAȚIE DE CONFORMITATE UE
EL-I VASTAVUSDEKLARATSIOON
ES ATBILSTĪBAS DEKLARĀCIJA
ES ATITIKTIES DEKLARACIJA
EU IZJAVA O SUKLADNOSTI
EU IZJAVA O USAGLAŠENOSTI

NETTLEHILL ROAD, HOUSTOUN INDUSTRIAL ESTATE, LIVINGSTON, EH54 5EQ, SCOTLAND, UNITED KINGDOM

hereby declares under its sole responsibility that the air conditioner(s) and heat pump(s) for use in residential, commercial, and light-industrial environments described below:
erklärt hiermit auf seine alleinige Verantwortung, dass die Klimaanlage(n) und Wärmepumpe(n) für das häusliche, kommerzielle und leichtindustrielle Umfeld wie unten beschrieben:
déclare par la présente et sous sa propre responsabilité que le(s) climatiseur(s) et la/les pompe(s) à chaleur destinés à un usage dans des environnements résidentiels, commerciaux et d'industrie légère décrits ci-dessous :
verklaart hierbij onder eigen verantwoordelijkheid dat de voor huishoudelijke, handels- en lichtindustriële omgevingen bestemde airconditioner(s) en warmtepomp(en) zoals onderstaand beschreven:
por la presente declara, bajo su exclusiva responsabilidad, que el(los) acondicionador(es) de aire y la(s) bomba(s) de calor previsto(s) para su uso en entornos residenciales, comerciales y de industria ligera que se describen a continuación:
conferma con la presente, sotto la sua esclusiva responsabilità, che i condizionatori d'aria e le pompe di calore destinati all'utilizzo in ambienti residenziali, commerciali e semi-industriali e descritti di seguito:
με το παρόν δηλώνει με αποκλειστική ευθύνη ότι το ή τα κλιματιστικά και η ή οι αντλίες θερμότητας για χρήση σε οικιακά, εμπορικά και ελαφρά βιομηχανικά περιβάλλοντα που περιγράφονται παρακάτω:
declara pela presente, e sob sua exclusiva responsabilidade, que o(s) aparelho(s) de ar condicionado e a(s) bomba(s) de calor destinados a utilização em ambientes residenciais, comerciais e de indústria ligeira descritos em seguida:
erklærer hermed under eneansvar, at det/de herunder beskrevne airconditionanlæg og varmepumpe(r) til brug i beboelses- og erhvervs miljøer samt i miljøer med let industri:
intyggar härmed att luftkonditioneringarna och värmepumparna som beskrivs nedan för användning i bostäder, kommersiella miljöer och lätta industriella miljöer:
декларира с настоящата на своя собствена отговорност, че климатикът(те) и термомоптата(ите), посочени по-долу и предназначени за употреба в жилищни, търговски и лекопромишлени среди:
niniejszym oświadczam na swoją wyłączną odpowiedzialność, że klimatyzatory i pompy ciepła do zastosowań w środowisku mieszkalnym, handlowym i lekko uprzemysłowionym opisane poniżej:
erklærer et fullstendig ansvar for undernevnte klimaanlegg og varmepumper ved bruk i boliger, samt kommersielle og lettindustrielle miljøer:
vakuuttaa täten yksinomaaisella vastuullaan, että jäljempänä kuvattut asuinrakennuksiin, pienteeollisuuskäyttöön ja kaupalliseen käyttöön tarkoitettut ilmastointilaitteet ja lämpöpumput:
tímto na vlastní odpovědnost prohlašuje, že níže popsané klimatizační jednotky a tepelná čerpadla pro použití v obytných prostředích, komerčních prostředích a prostředích lehkého průmyslu:
týmto na svoju výlučnú zodpovednosť vyhlasuje, že nasledovné klimatizačné jednotky a tepelné čerpadlá určené na používanie v obytných a obchodných priestoroch a v prostredí ľahkého priemyslu:
alulírott kizárólagos felelősségére nyilatkozik, hogy az alábbi lakossági, kereskedelmi és kisipari környezetben való használatra szánt klímaberendezés(ek) és hőszivattyú(k):
na lastno odgovornost izjavlja, da so spodaj opisane klimatske naprave in toplotne črpalke, namenjene za uporabo v stanovanjskih, poslovnih in lahkoindustrijskih okoljih:
declara prin prezenta, pe proprie răspundere, faptul că aparatele de climatizare și pompele de căldură descrise mai jos și destinate utilizării în medii rezidențiale, comerciale și din industria ușoară:
kinnitab oma ainuvastutuse, et alpool toodud elu-, äri- ja kergtööstuskeskkondades kasutamiseks mõeldud kliimaseadmed ja soojuspumbad:
ar šo, vienpersoniski uzņemoties atbildību, paziņo, ka tālāk aprakstītais(-tīte) gaisa kondicionētājs(-i) un siltumsūkņis(-i) ir paredzēti lietošanai dzīvojamajās, komercdarbības un vieglās rūpniecības telpās, kas aprakstītas tālāk:
šiuo vien tik savo atsakomybe pareiškia, kad toliau apibūdintas (-i) oro kondicionierius (-iai) ir šilumos siurblys (-iai), skirtas (-i) naudoti toliau apibūdintose gyvenamosiose, komercinėse ir lengvosios pramonės aplinkose:
ovime izjavljuje pod isključivom odgovornošću da je/su klimatizacijski uređaj(i) i toplinska dizalica(e) opisan(i) u nastavku namijenjen(i) za upotrebu u stambenim i poslovnim okruženjima te okruženjima lake industrije:
ovim izjavljuje na svoju isključivu odgovornost da su klima-uređaji i toplotne pumpe za upotrebu u stambenim, komercijalnim okruženjima i okruženjima lake industrije opisani u nastavku:

NETTLEHILL ROAD, HOUSTOUN INDUSTRIAL ESTATE, LIVINGSTON, EH54 5EQ, SCOTLAND, UNITED KINGDOM

is/are in conformity with provisions of the following Union harmonisation legislation.
die Bestimmungen der folgenden Harmonisierungsrechtsvorschriften der Union erfüllt/erfüllen.
est/son conforme(s) aux dispositions de la législation d'harmonisation de l'Union suivante.
voldoet/voldoen aan bepalingen van de volgende harmonisatiewetgeving van de Unie.
cumple(n) con las disposiciones de la siguiente legislación de armonización de la Unión.
sono in conformità con le disposizioni della seguente normativa dell'Unione sull'armonizzazione.
συμμορφώνονται με τις διατάξεις της ακόλουθης νομοθεσίας εναρμόνισης της Ένωσης.
está/estão em conformidade com as disposições da seguinte legislação de harmonização da União.
er i overensstemmelse med bestemmelse i følgende harmoniserede EU-lovgivning.
uppfyller villkoren i följande harmoniserade föreskrifter inom unionen.
e/са в съответствие с разпоредбите на следното законодателство на Съюза за хармонизация.

sa zgodne z przepisami następującego unijnego prawodawstwa harmonizacyjnego.
er i samsvar med forskriftene til følgende EU-lovgivning om harmonisering.
ovat seuraavan unionin yhdenmukaistamislainsäädännön säännösten mukaisia.
jsou v souladu s ustanoveními následujících harmonizačních právních předpisů Unie.
splňajú ustanovenia nasledujúcich harmonizovaných noriem EÚ.
megfelel(nek) az Unió alábbi harmonizációs jogszabályi előírásainak.
v skladu z določbami naslednje usklajevalne zakonodaje Unije.
sunt în conformitate cu dispozițiile următoare legislației de armonizare a Uniunii.
vastavad järgmist Euroopa Liidu ühtlustatud õigusaktide sätetele.
atbilst šādiem ES harmonizētajiem tiesību aktu noteikumiem.
taip pat atitinka kitų toliau išvardytų suderintųjų Sąjungos direktyvų nuostatas.
sukladan(i) odredbama sljedećeg zakonodavstva Unije za sukladnost.
u skladu sa odredbama sledećeg uskladjivanja zakonodavstva Unije.

2014/35/EU: Low Voltage
2006/42/EC: Machinery
2014/30/EU: Electromagnetic Compatibility
2009/125/EC: Energy-related Products Directive and Regulation (EU) No 813/2013
2011/65/EU, (EU) 2015/863 and (EU) 2017/2102: RoHS Directive

UK DECLARATION OF CONFORMITY

mitsubishi electric air conditioning systems europe ltd.
NETTLEHILL ROAD, HOUSTOUN INDUSTRIAL ESTATE, LIVINGSTON, EH54 5EQ, SCOTLAND, UNITED KINGDOM

hereby declares under its sole responsibility that the air conditioner(s) and heat pump(s) for use in residential, commercial, and light-industrial environments described below:

mitsubishi electric, ehpt20x-meheW

is/are in conformity with provisions of the following UK legislation

The Electrical Equipment (Safety) Regulations 2016
The Supply of Machinery (Safety) Regulations 2008
The Electromagnetic Compatibility Regulations 2016
The Restriction of the Use of Certain Hazardous Substances in Electrical and Electronic Equipment Regulations 2012
The Ecodesign for Energy-Related Products Regulations 2010

Issued:
UNITED KINGDOM

30 April 2023

Kengo TAKAHASHI
Manager, Quality Assurance Department

The copyright of the fonts displayed on the main remote controller screen belongs to Morisawa Inc..

This product is designed and intended for use in the residential, commercial and light-industrial environment.

Importer:

Mitsubishi Electric Europe B.V.
Capronilaan 34, 1119 NS, Schiphol Rijk, The Netherlands

French Branch
2, Rue De L'Union, 92565 RUEIL MAISON Cedex



German Branch
Mitsubishi-Electric-Platz 1 40882 Ratingen North Rhine-Westphalia Germany

Belgian Branch
8210 Loppem, Autobaan 2, Belgium

Irish Branch
Westgate Business Park, Ballymount Road, Upper Ballymount, Dublin 24, Ireland

Italian Branch
Via Energy Park, 14 20871 Vimercate (MB), Italy

Norwegian Branch
Gneisveien 2D, 1914 Ytre Enebakk, Norway

Portuguese Branch
Avda. do Forte 10, 2794-019 Carnaxide, Lisbon, Portugal

Spanish Branch
Av. Castilla, 2 Parque Empresarial San Fernando - Ed. Europa, 28830 San Fernando de Henares (Madrid), Spain

Scandinavian Branch
Hammarbacken 14, P.O. Box 750, SE-19127, Sollentuna, Sweden

UK Branch
Travellers Lane, Hatfield, Hertfordshire, AL10 8XB, United Kingdom

Polish Branch
Krakowska 50, PL-32-083 Balice, Poland

ООО «Мицубиси Электрик (РУС)»
115114, Российская Федерация, г. Москва, ул. Летниковская, д. 2, стр. 1, 5 этаж

Please be sure to put the contact address/telephone number on this manual before handing it to the customer.

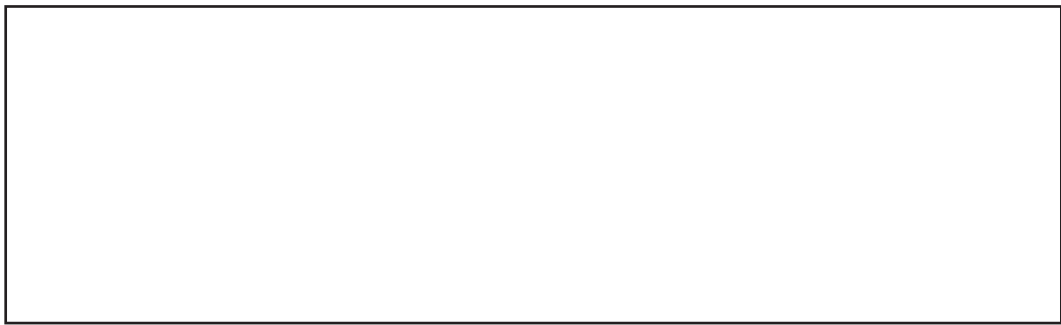

mitsubishi electric corporation

HEAD OFFICE: TOKYO BUILDING, 2-7-3, MARUNOUCHI, CHIYODA-KU, TOKYO 100-8310, JAPAN