

AIR CONDITIONING SYSTEMS

CITY MULTI



DATA BOOK

MODEL

PFFY-P-VEM-E

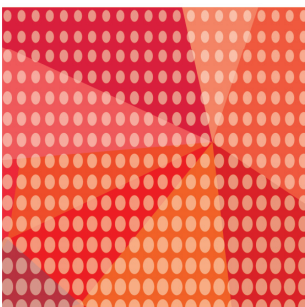

PFFY-P-VEM-E

1. SPECIFICATIONS	2
2. EXTERNAL DIMENSIONS	4
3. CENTER OF GRAVITY	10
4. ELECTRICAL WIRING DIAGRAMS	11
5. SOUND LEVELS	12
5-1. Sound levels	12
5-2. NC curves	12
6. TEMPERATURE/AIRFLOW DISTRIBUTIONS	13
6-1. Temperature distributions	13
6-2. Airflow distributions	14
7. ELECTRICAL CHARACTERISTICS	15
8. OPTIONAL PARTS	16
8-1. Optional parts line up for the Indoor unit	16
8-2. Back decoration panel	16

1. SPECIFICATIONS

Floor standing (Exposed type)

PFFY-P-VEM-E

Model		PFFY-P20VEM-E	PFFY-P25VEM-E	PFFY-P32VEM-E	PFFY-P40VEM-E
Power source		1-phase 220-230-240 V 50/60 Hz	1-phase 220-230-240 V 50/60 Hz	1-phase 220-230-240 V 50/60 Hz	1-phase 220-230-240 V 50/60 Hz
Cooling capacity (Nominal)	*1 kW	2.2	2.8	3.6	4.5
	*1 BTU/h	7,500	9,600	12,300	15,400
	Power input kW	0.021	0.026	0.031	0.037
	Current input A	0.26-0.25-0.24	0.31-0.30-0.29	0.37-0.35-0.34	0.39-0.38-0.36
Heating capacity (Nominal)	*2 kW	2.5	3.2	4.0	5.0
	*2 BTU/h	8,500	10,900	13,600	17,100
	Power input kW	0.021	0.026	0.031	0.037
	Current input A	0.26-0.25-0.24	0.31-0.30-0.29	0.37-0.35-0.34	0.39-0.38-0.36
External finish		Galvanized steel plate, MUNSSELL (1.0Y 9.2/0.2)/ABS, MUNSSELL (5.32GY 8.75/0.37)	Galvanized steel plate, MUNSSELL (1.0Y 9.2/0.2)/ABS, MUNSSELL (5.32GY 8.75/0.37)	Galvanized steel plate, MUNSSELL (1.0Y 9.2/0.2)/ABS, MUNSSELL (5.32GY 8.75/0.37)	Galvanized steel plate, MUNSSELL (1.0Y 9.2/0.2)/ABS, MUNSSELL (5.32GY 8.75/0.37)
External dimension H x W x D		*3 mm	669 (726) x 1,142 x 217	669 (726) x 1,142 x 217	669 (726) x 1,142 x 217
		*3 in.	26-3/8 (28-5/8) x 45 x 8-9/16	26-3/8 (28-5/8) x 45 x 8-9/16	26-3/8 (28-5/8) x 45 x 8-9/16
Net weight		kg (lbs)	29.5 (67)	29.5 (67)	30 (67)
Heat exchanger		Cross fin (Aluminum fin and copper tube)	Cross fin (Aluminum fin and copper tube)	Cross fin (Aluminum fin and copper tube)	Cross fin (Aluminum fin and copper tube)
FAN	Type x Quantity		Sirocco fan x 2	Sirocco fan x 2	Sirocco fan x 2
	External static press.	Pa	0	0	0
		mmH ₂ O	0.0	0.0	0.0
	Motor Type		DC motor	DC motor	DC motor
	Motor output kW		0.096	0.096	0.096
	Driving mechanism		Direct-driven by motor	Direct-driven by motor	Direct-driven by motor
	Air flow rate		(Low-Mid-High)	(Low-Mid-High)	(Low-Mid-High)
m ³ /min			5.0 - 6.0 - 7.0	5.5 - 6.5 - 8.0	5.5 - 7.0 - 8.5
L/s			83 - 100 - 117	92 - 108 - 133	92 - 117 - 142
		cfm	177 - 212 - 247	194 - 230 - 282	194 - 247 - 300
Sound pressure level (measured in anechoic room)		(Low-Mid-High)	(Low-Mid-High)	(Low-Mid-High)	
		dB <A>	23.0-27.0-31.0	25.0-29.0-34.0	25.0-31.0-36.0
Insulation material		Polystyrene foam, Polyethylene foam, Urethane foam	Polystyrene foam, Polyethylene foam, Urethane foam	Polystyrene foam, Polyethylene foam, Urethane foam	Polystyrene foam, Polyethylene foam, Urethane foam
Air filter		PP honeycomb fabric.	PP honeycomb fabric.	PP honeycomb fabric.	PP honeycomb fabric.
Protection device		Fuse	Fuse	Fuse	Fuse
Refrigerant control device		LEV	LEV	LEV	LEV
Connectable outdoor unit		R410A CITY MULTI	R410A CITY MULTI	R410A CITY MULTI	R410A CITY MULTI
Refrigerant piping diameter	Liquid (R410A)	mm (in.)	6.35 (1/4)Braze	6.35 (1/4)Braze	6.35 (1/4)Braze
	Gas (R410A)	mm (in.)	12.7 (1/2)Braze	12.7 (1/2)Braze	12.7 (1/2)Braze
Field drain pipe size		mm (in.)	O.D.32 (1-1/4)	O.D.32 (1-1/4)	O.D.32 (1-1/4)
Drawing	External		KB94C45F, KB94C45G	KB94C45F, KB94C45G	KB94C45F, KB94C45G
	Wiring		KB94C4K2	KB94C4K2	KB94C4K2
	Refrigerant cycle		-	-	-
Standard attachment	Document		Installation Manual, Instruction Book	Installation Manual, Instruction Book	Installation Manual, Instruction Book
	Accessory		Washer, Drain hose, Tie band, Leg, Leg cover, M4 screw, M5 screw	Washer, Drain hose, Tie band, Leg, Leg cover, M4 screw, M5 screw	Washer, Drain hose, Tie band, Leg, Leg cover, M4 screw, M5 screw
Optional parts		Back decoration panel	PAC-BP32VEM-E	PAC-BP32VEM-E	PAC-BP50VEM-E
Remarks		* Details on foundation work, duct work, insulation work, electrical wiring, power source switch, and other items shall be referred to the Installation Manual. * Due to continuing improvement, above specifications may be subject to change without notice.			

Notes:	1.Nominal cooling conditions Indoor: 27°C.D.B./19°C.W.B. (81°F.D.B./66°F.W.B.), Outdoor: 35°C.D.B. (95°F.D.B.) Pipe length: 7.5 m (24-9/16 ft.), Level difference: 0 m (0 ft.)	Unit converter BTU/h =kW x 3.412 cfm =m ³ /min x 35.31 lbs =kg/0.4536
	2.Nominal heating conditions Indoor: 20°C.D.B. (68°F.D.B.), Outdoor: 7°C.D.B./6°C.W.B. (45°F.D.B./43°F.W.B.) Pipe length: 7.5 m (24-9/16 ft.), Level difference: 0 m (0 ft.)	
	3.The values in () show the height of unit with leg.	
	*Above specification data is subject to rounding variation.	

1. SPECIFICATIONS

Floor standing (Exposed type)

PFFY-P-VEM-E

Model		PFFY-P50VEM-E		PFFY-P63VEM-E		
Power source		1-phase 220-230-240 V 50/60 Hz		1-phase 220-230-240 V 50/60 Hz		
Cooling capacity (Nominal)	*1 kW	5.6		7.1		
	*1 BTU/h	19,100		24,200		
	Power input	0.054		0.061		
	Current input	0.58-0.56-0.55		0.52-0.50-0.48		
Heating capacity (Nominal)	*2 kW	6.3		8.0		
	*2 BTU/h	21,500		27,300		
	Power input	0.054		0.061		
	Current input	0.58-0.56-0.55		0.52-0.50-0.48		
External finish		Galvanized steel plate, MUNSSELL (1.0Y 9.2/0.2)/ABS, MUNSSELL (5.32GY 8.75/0.37)		Galvanized steel plate, MUNSSELL (1.0Y 9.2/0.2)/ABS, MUNSSELL (5.32GY 8.75/0.37)		
External dimension H x W x D		*3 mm	669 (726) x 1,342 x 217		669 (726) x 1,542 x 217	
		*3 in.	26-3/8 (28-5/8) x 52-7/8 x 8-9/16		26-3/8 (28-5/8) x 60-3/4 x 8-9/16	
Net weight		kg (lbs)	35 (78)		39.5 (89)	
Heat exchanger		Cross fin (Aluminum fin and copper tube)		Cross fin (Aluminum fin and copper tube)		
FAN	Type x Quantity		Sirocco fan x 3		Sirocco fan x 4	
	External static press.	Pa	0		0	
		mmH ₂ O	0.0		0.0	
	Motor Type		DC motor		DC motor	
	Motor output		0.096		0.096	
	Driving mechanism		Direct-driven by motor		Direct-driven by motor	
	Air flow rate		(Low-Mid-High)		(Low-Mid-High)	
			m ³ /min	10.0 - 11.5 - 13.5		12.0 - 14.0 - 16.5
L/s			167 - 192 - 225		200 - 233 - 275	
		cfm	353 - 406 - 477		424 - 494 - 583	
Sound pressure level (measured in anechoic room)		(Low-Mid-High)		(Low-Mid-High)		
		dB <A>	34.0-37.0-41.0		32.0-36.0-40.0	
Insulation material		Polystyrene foam, Polyethylene foam, Urethane foam		Polystyrene foam, Polyethylene foam, Urethane foam		
Air filter		PP honeycomb fabric.		PP honeycomb fabric.		
Protection device		Fuse		Fuse		
Refrigerant control device		LEV		LEV		
Connectable outdoor unit		R410A CITY MULTI		R410A CITY MULTI		
Refrigerant piping diameter	Liquid (R410A)	mm (in.)	6.35 (1/4)Braze		9.52 (3/8)Braze	
	Gas (R410A)	mm (in.)	12.7 (1/2)Braze		15.88 (5/8)Braze	
Field drain pipe size		mm (in.)	O.D.32 (1-1/4)		O.D.32 (1-1/4)	
Drawing	External		KB94C45F, KB94C45G		KB94C45F, KB94C45G	
	Wiring		KB94C4K2		KB94C4K2	
	Refrigerant cycle		-		-	
Standard attachment	Document		Installation Manual, Instruction Book		Installation Manual, Instruction Book	
	Accessory		Washer, Drain hose, Tie band, Leg, Leg cover, M4 screw, M5 screw		Washer, Drain hose, Tie band, Leg, Leg cover, M4 screw, M5 screw	
Optional parts	Back decoration panel		PAC-BP50VEM-E		PAC-BP63VEM-E	
Remarks		* Details on foundation work, duct work, insulation work, electrical wiring, power source switch, and other items shall be referred to the Installation Manual. * Due to continuing improvement, above specifications may be subject to change without notice.				

Notes:

- Nominal cooling conditions
Indoor: 27°C D.B./19°C W.B. (81°F D.B./66°F W.B.), Outdoor: 35°C D.B. (95°F D.B.)
Pipe length: 7.5 m (24-9/16 ft.), Level difference: 0 m (0 ft.)
- Nominal heating conditions
Indoor: 20°C D.B. (68°F D.B.), Outdoor: 7°C D.B./6°C W.B. (45°F D.B./43°F W.B.)
Pipe length: 7.5 m (24-9/16 ft.), Level difference: 0 m (0 ft.)
- The values in () show the height of unit with leg.

Unit converter	
BTU/h	=kW x 3,412
cfm	=m ³ /min x 35.31
lbs	=kg/0.4536
*Above specification data is subject to rounding variation.	

PFFY-P20, 25, 32, 40, 50, 63VEM-E - wall mounting

Unit: mm

- Note 1. Use an M10 screw for the wall and floor mounting bolt (field supply).
 2. This drawing is for PFFY-P63VEM-E model, which have 4 fans.
 PFFY-P40-50VEM-E models have 3 fans.
 PFFY-P20-25-32VEM-E models have 2 fans.

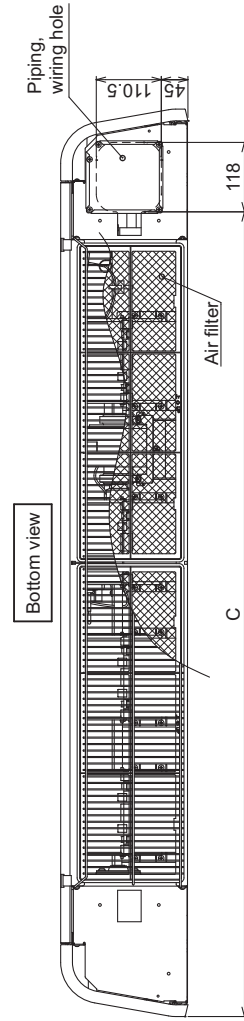
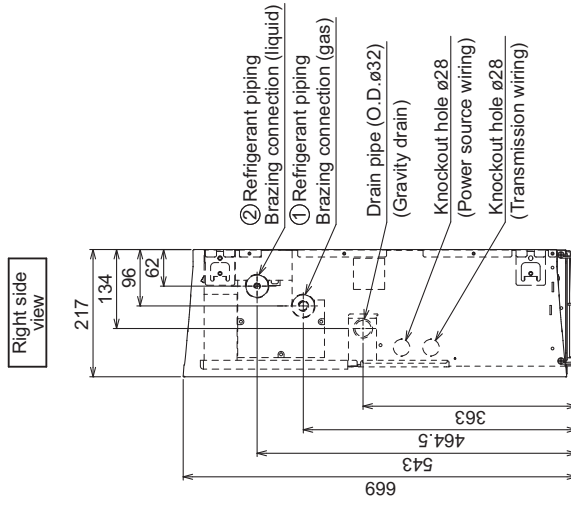
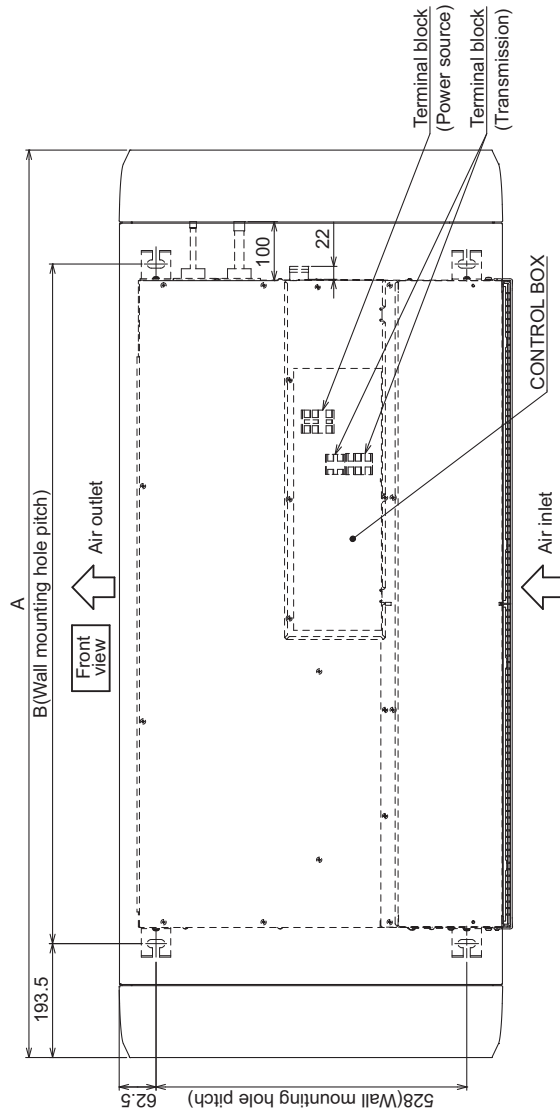
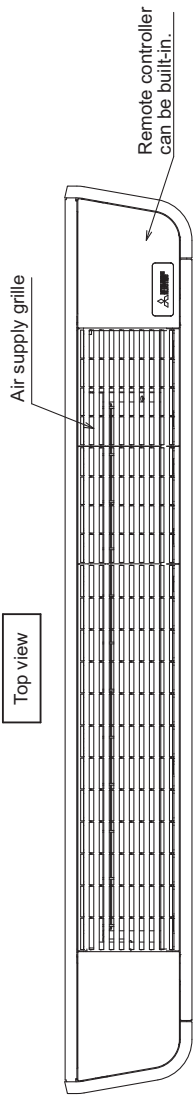

Model	A	B	C	① Gas pipe	② Liquid pipe
PFFY-P20-25-32VEM-E	1142	755	967.5	ø12.7	ø6.35
PFFY-P40-50VEM-E	1342	955	1167.5	ø15.88	ø9.52
PFFY-P63VEM-E	1542	1155	1367.5	ø15.88	ø9.52

PFFY-P20, 25, 32, 40, 50, 63VEM-E - wall mounting

Unit: mm

[Maintenance access space]
Secure enough access space to allow for the maintenance, inspection,
and replacement of the motor, fan, heat exchanger, drain pan and control box.

Note 3. When the unit is installed on the wall,
vibrations may be transmitted to the wall.
Take measures against vibrations as needed at the site.

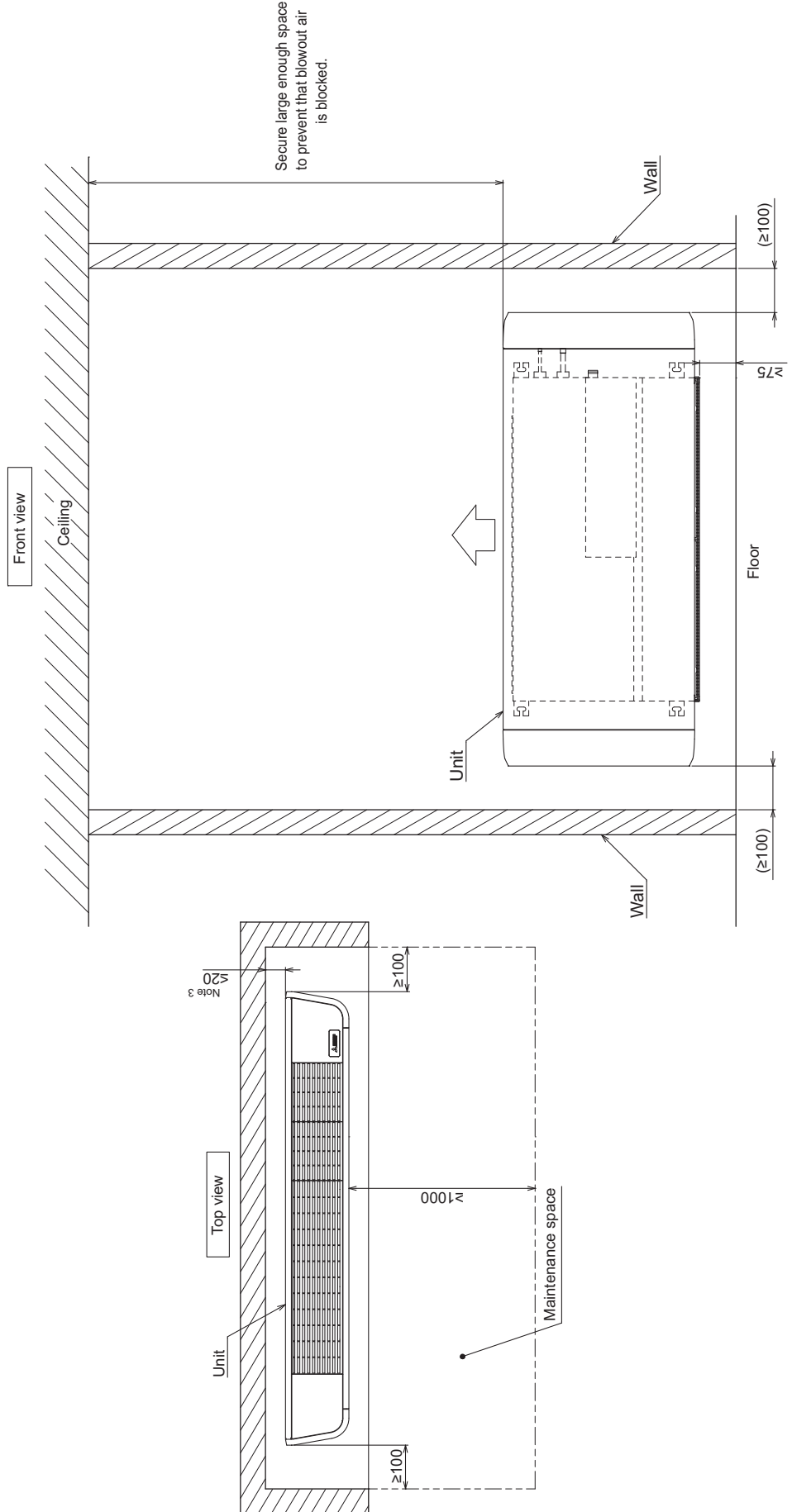

PFFY-P20, 25, 32, 40, 50, 63VEM-E - floor mounting

Unit: mm

- Note 1. Use an M10 screw for the wall and floor mounting bolt (field supply).
 2. This drawing is for PFFY-P63VEM-E model, which have 4 fans.
 PFFY-P40-50VEM-E models have 3 fans.
 PFFY-P20-25-32VEM-E models have 2 fans.

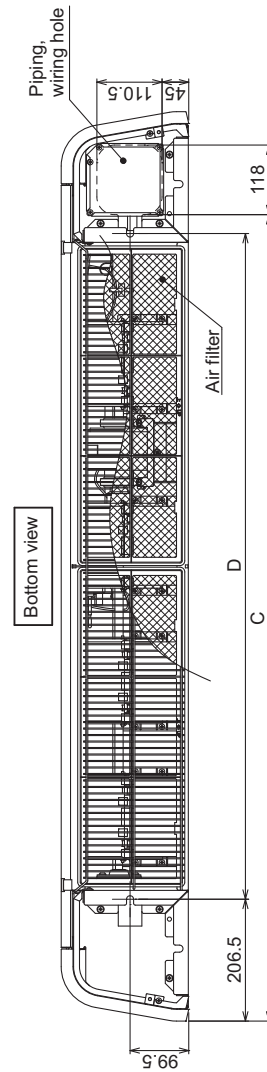
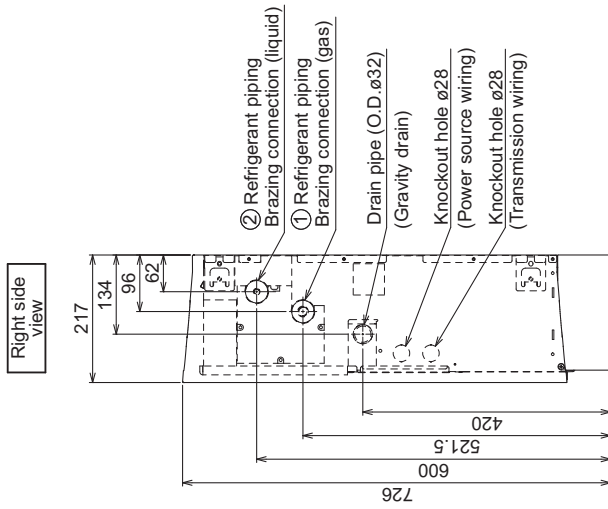
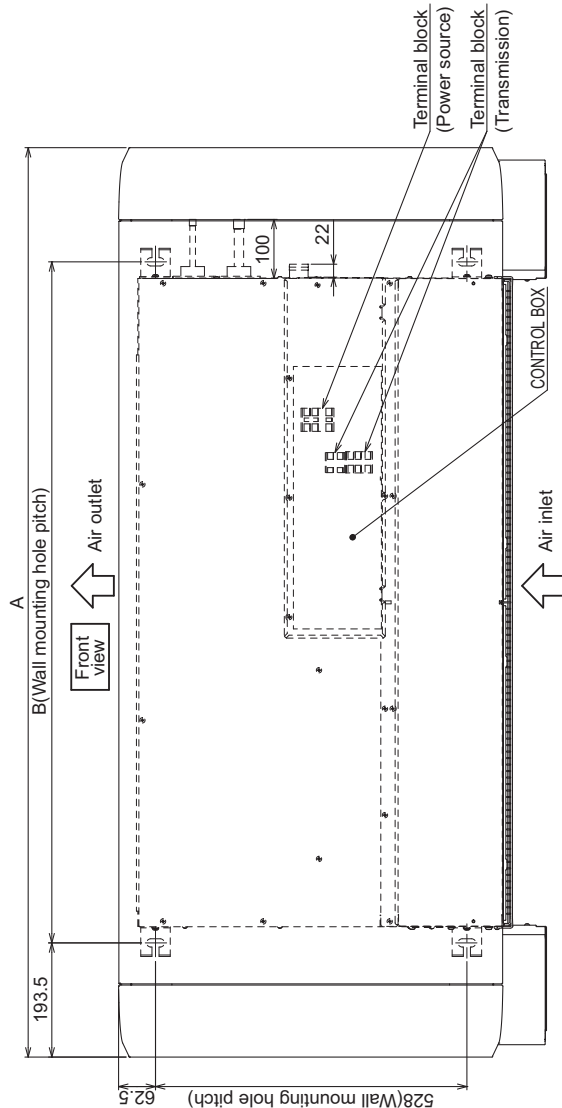
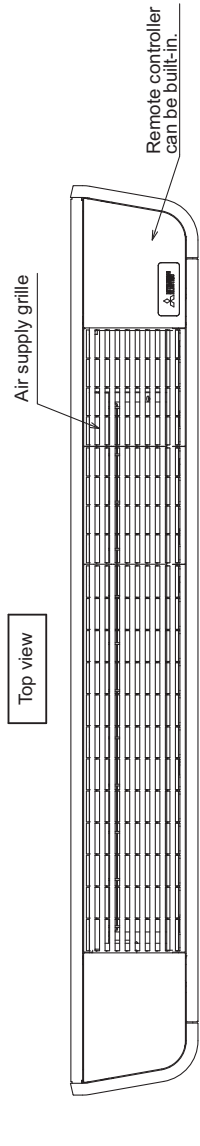

Model	A	B	C	D	① Gas pipe	② Liquid pipe
PFFY-P20-25-32VEM-E	1142	755	967.5	729		
PFFY-P40-50VEM-E	1342	955	1167.5	929	ø12.7	ø6.35
PFFY-P63VEM-E	1542	1155	1367.5	1129	ø15.88	ø9.52

PFFY-P20, 25, 32, 40, 50, 63VEM-E - floor mounting

Unit: mm

Note 3. When the unit is installed on the wall, vibrations may be transmitted to the wall. Take measures against vibrations as needed at the site.

[Maintenance access space]
Secure enough access space to allow for the maintenance, inspection, and replacement of the motor, fan, heat exchanger, drain pan and control box.

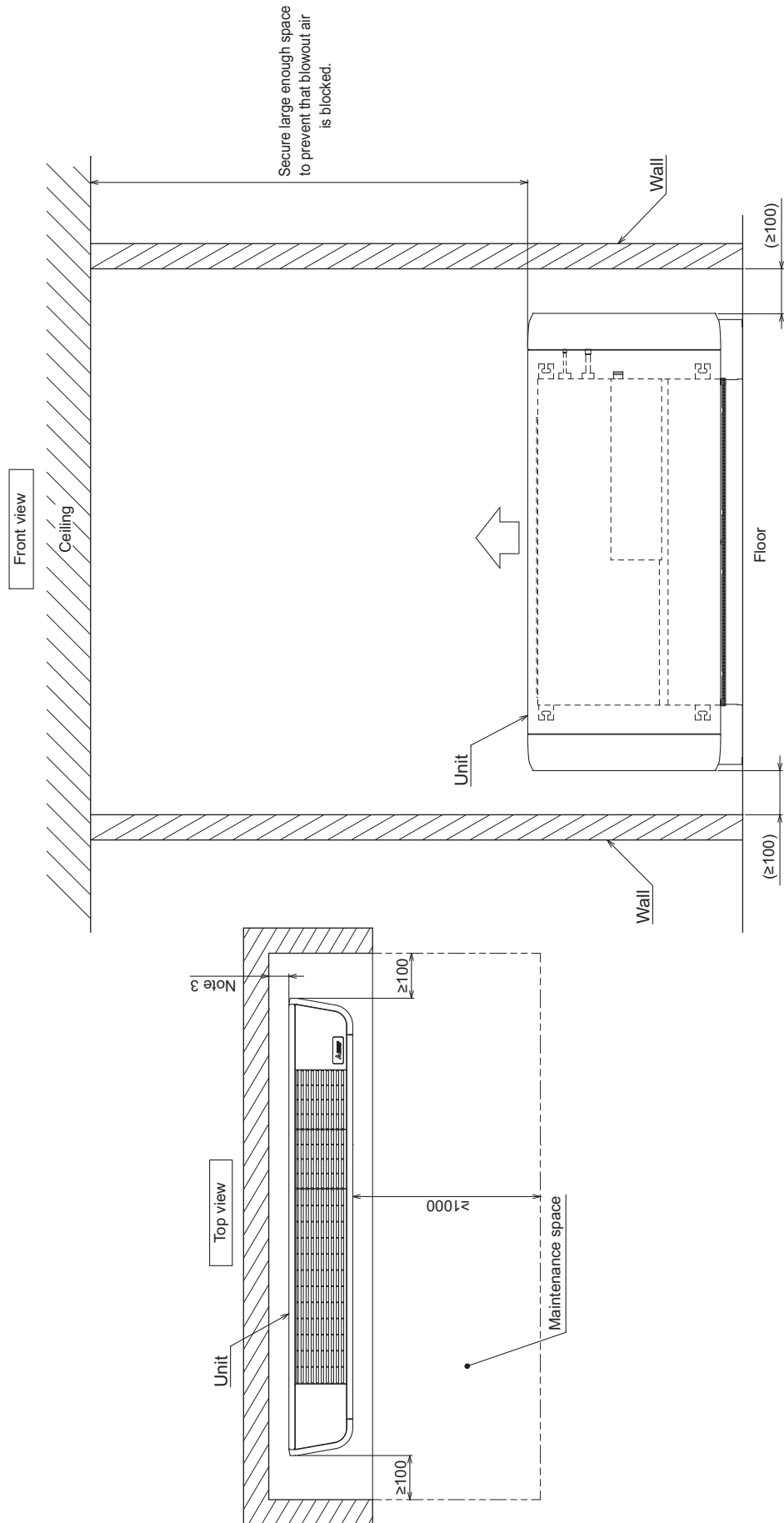

PFFY-P20, 25, 32, 40, 50, 63VEM-E - back panel installation - floor mounting

Unit: mm

- Note 1. Use an M10 screw for the wall and floor mounting bolt (field supply).
 2. This drawing is for PFFY-P63VEM-E model, which have 4 fans.
 PFFY-P40-50VEM-E models have 3 fans.
 PFFY-P20-25-32VEM-E models have 2 fans.

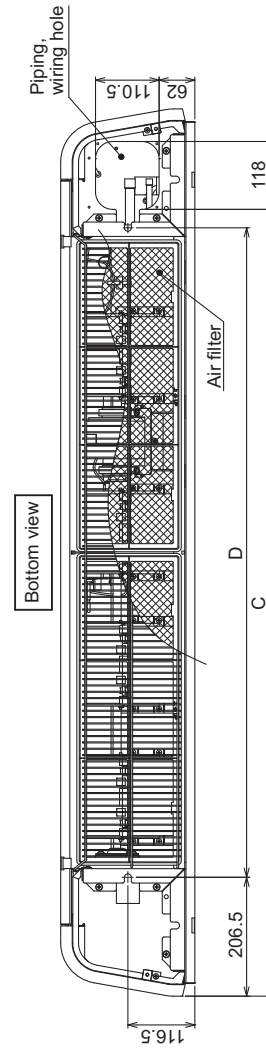
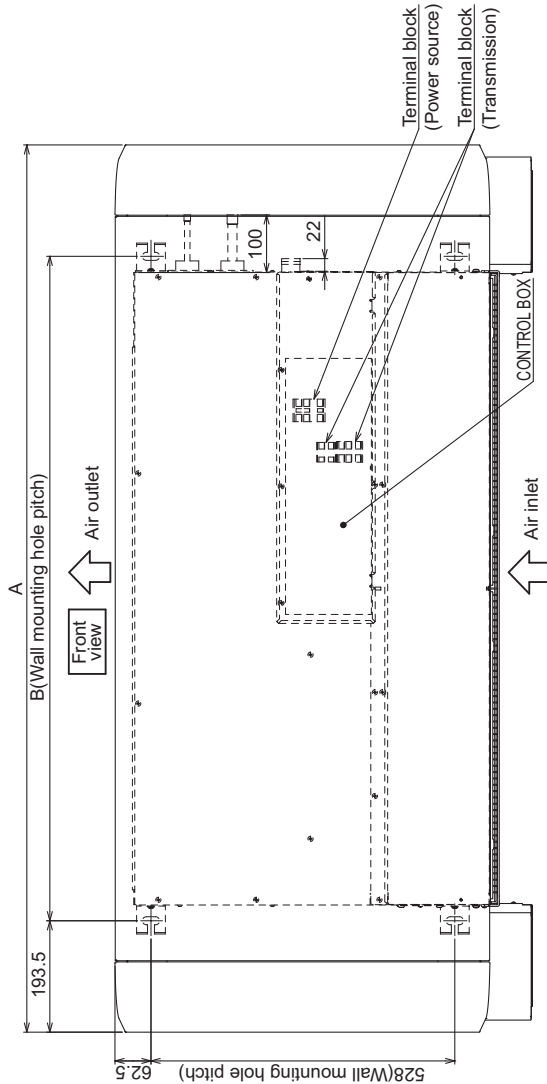
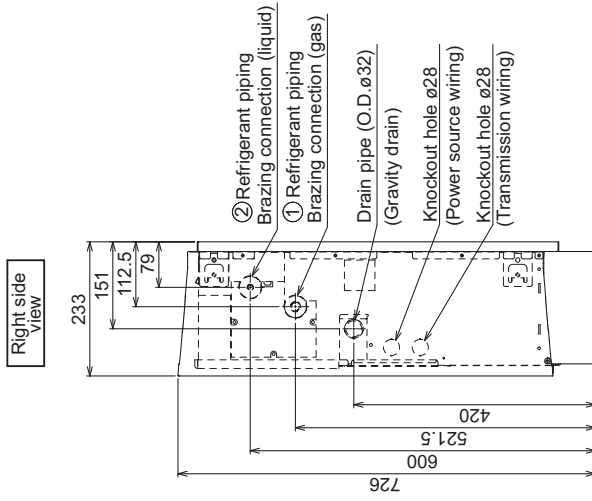
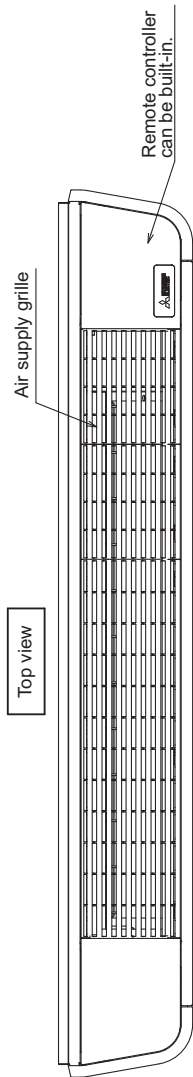

Model	A	B	C	D	① Gas pipe	② Liquid pipe
PFFY-P20-25-32VEM-E	1142	755	967.5	729	ø12.7	ø6.35
PFFY-P40-50VEM-E	1342	955	1167.5	929	ø15.88	ø9.52
PFFY-P63VEM-E	1542	1155	1367.5	1129	ø15.88	ø9.52

PFFY-P20, 25, 32, 40, 50, 63VEM-E - back panel installation - floor mounting

Unit: mm

- [Maintenance access space]
Secure enough access space to allow for the maintenance, inspection, and replacement of the motor, fan, heat exchanger, drain pan and control box.
- Note 3. Install the back panel before floor mounting.
4. The back panel can not be removed once it is floor mounting.
5. When the unit is installed on the wall, vibrations may be transmitted to the wall. Take measures against vibrations as needed at the site.

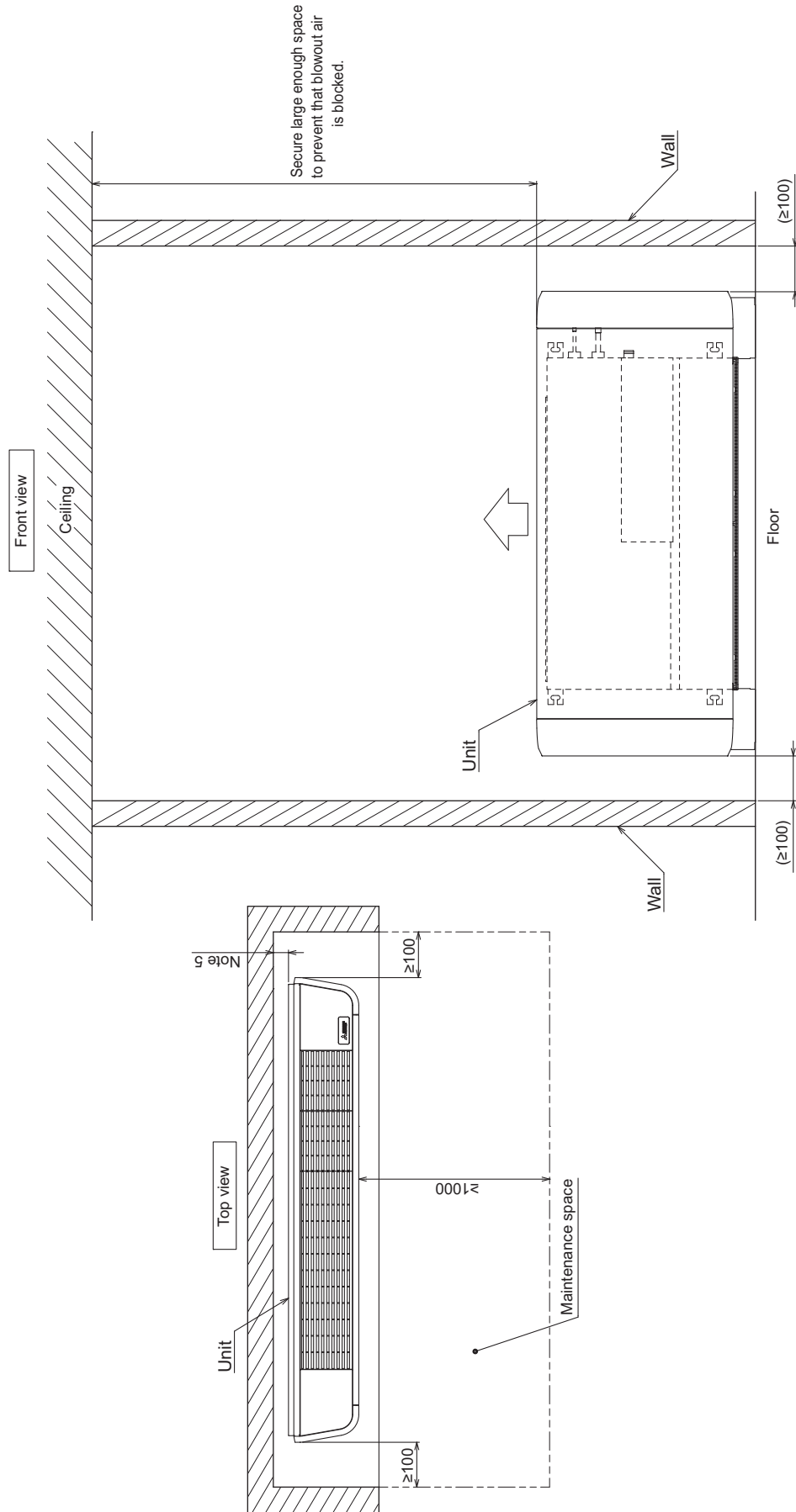

PFFY-P20, 25, 32, 40, 50, 63VEM-E

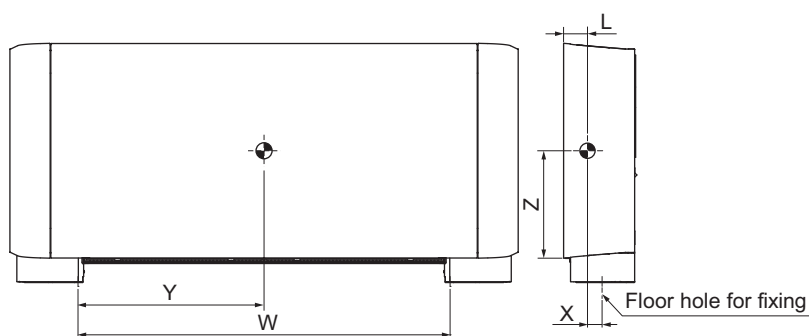

(mm) [in]

Model name	W	L	X	Y	Z
PFFY-P20VEM-E	730 [28-3/4]	76 [3]	40 [1-5/8]	365 [14-3/8]	320 [12-5/8]
PFFY-P25VEM-E	730 [28-3/4]	76 [3]	40 [1-5/8]	365 [14-3/8]	320 [12-5/8]
PFFY-P32VEM-E	730 [28-3/4]	76 [3]	40 [1-5/8]	365 [14-3/8]	320 [12-5/8]
PFFY-P40VEM-E	930 [36-5/8]	76 [3]	40 [1-5/8]	475 [18-3/4]	330 [13]
PFFY-P50VEM-E	930 [36-5/8]	76 [3]	40 [1-5/8]	475 [18-3/4]	330 [13]
PFFY-P63VEM-E	1130 [44-1/2]	76 [3]	40 [1-5/8]	595 [23-7/16]	340 [13-7/16]

PFFY-P20, 25, 32, 40, 50, 63VEM-E

SYMBOL	NAME
ACL	AC reactor (Power factor improvement)
MF	Fan Motor
LEV	Electrical linear expansion valve
TB2	Power source terminal block
TB5	Transmission terminal block
TH21	Thermistor (inlet air temp. detection)
TH22	Thermistor (piping temp.detection/liquid)
TH23	Thermistor (piping temp.detection/gas)
I.B.	Indoor controller board
SA	Arrester
F1	Fuse AC250V 6.3A
ZNR001	Varistor
ZNR002	Varistor
CN22	Connector (Optional Thermistor)
CN32	Connector (Remote switch)
CN41	Connector (HA terminal-A)
CN51	Connector (Centrally control)
CN52	Connector (Remote indication)
CN90	Connector (Wireless)
CN105	Connector (IT terminal)
SW1	Switch (for mode selection)
SW2	Switch (for capacity code)
SW3	Switch (for mode selection)
SW4	Switch (for model selection)
SW11	Switch (1s digit address set)
SW12	Switch (10s digit address set)
SW14	Switch (BRANCH No.)
SW21	Switch (for mode selection)
SW22	Switch (Wireless pair No.)
SWE	Connector (emergency operation)
LED1	LED (Power supply)
LED2	LED (Remote controller supply)

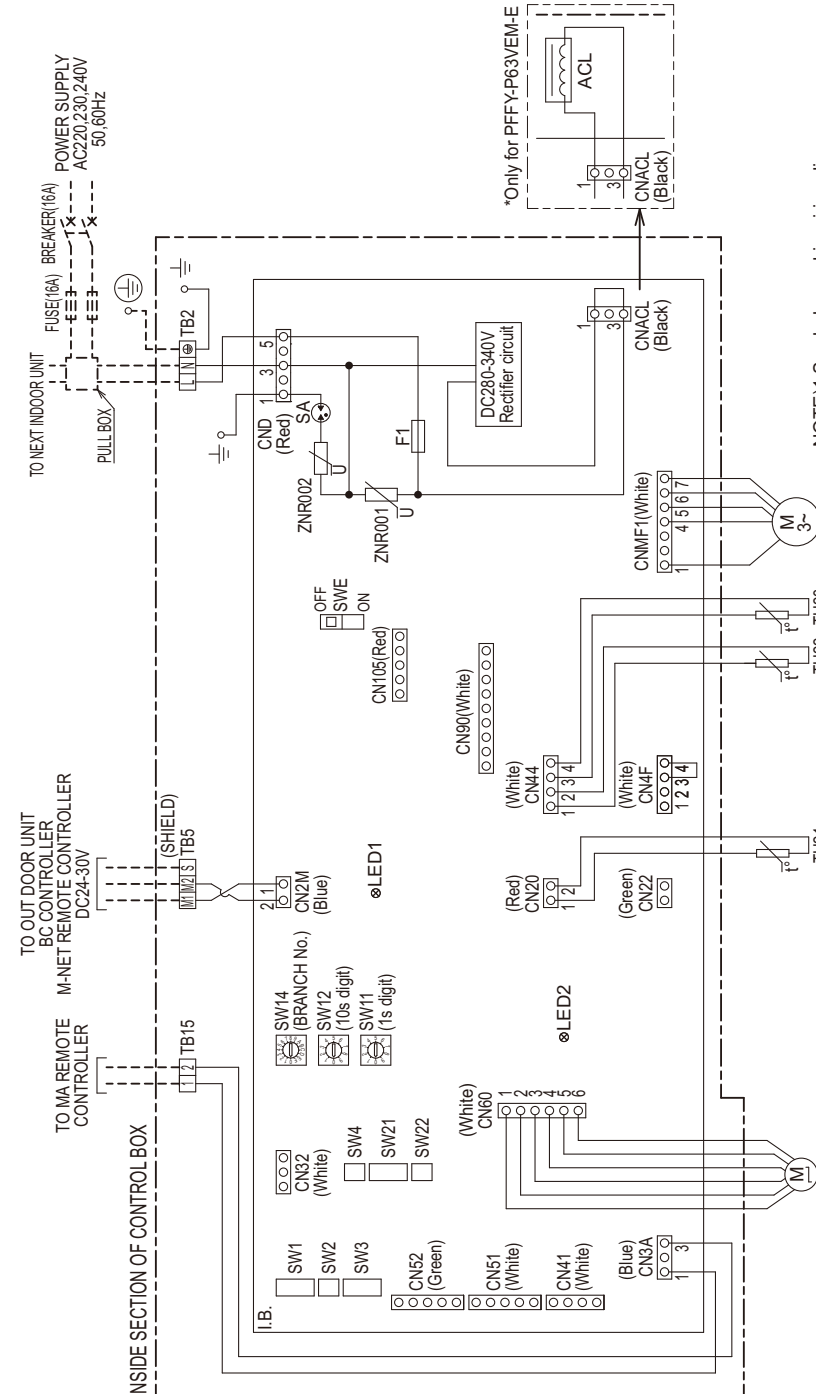

NOTE) 1. Symbols used in wiring diagram are

- ○ ○ ○ : Connector, □ : Terminal,
 - (Heavy dotted line) : Field wiring,
 - (Thin dotted line) : Optional parts.
2. Have all electric work done by a licensed electrician according to the local regulations.
 3. Earth leakage circuit breaker should be set up on the wiring of the power supply.

MODEL	SW1	SW2	SW3	SW4	SW21	SW22	SWE
PFFY-P20VEM-E	ON 1 2 3 4 5 6 7 8 9 10	ON 1 2 3 4 5 6	ON 1 2 3 4 5 6 7 8 9 10	ON 1 2 3 4 5 6	ON 1 2 3 4 5 6 7 8	ON 1 2 3 4	ON OFF
PFFY-P25VEM-E	ON 1 2 3 4 5 6 7 8 9 10	ON 1 2 3 4 5 6	ON 1 2 3 4 5 6 7 8 9 10	ON 1 2 3 4 5 6	ON 1 2 3 4 5 6 7 8	ON OFF	ON OFF
PFFY-P32VEM-E	ON 1 2 3 4 5 6 7 8 9 10	ON 1 2 3 4 5 6	ON 1 2 3 4 5 6 7 8 9 10	ON 1 2 3 4 5 6	ON 1 2 3 4 5 6 7 8	ON OFF	ON OFF
PFFY-P40VEM-E	ON 1 2 3 4 5 6 7 8 9 10	ON 1 2 3 4 5 6	ON 1 2 3 4 5 6 7 8 9 10	ON 1 2 3 4 5 6	ON 1 2 3 4 5 6 7 8	ON OFF	ON OFF
PFFY-P50VEM-E	ON 1 2 3 4 5 6 7 8 9 10	ON 1 2 3 4 5 6	ON 1 2 3 4 5 6 7 8 9 10	ON 1 2 3 4 5 6	ON 1 2 3 4 5 6 7 8	ON OFF	ON OFF
PFFY-P63VEM-E	ON 1 2 3 4 5 6 7 8 9 10	ON 1 2 3 4 5 6	ON 1 2 3 4 5 6 7 8 9 10	ON 1 2 3 4 5 6	ON 1 2 3 4 5 6 7 8	ON OFF	ON OFF

5-1. Sound levels

PFFY-P-VEM-E

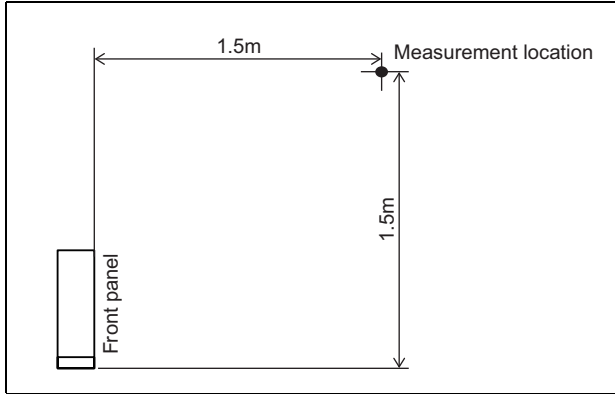

* Measured in anechoic room

Sound level at anechoic room: Low-Mid-High

	Sound level dB (A)
PFFY-P20VEM-E	23.0-27.0-31.0
PFFY-P25VEM-E	25.0-29.0-34.0
PFFY-P32VEM-E	25.0-31.0-36.0
PFFY-P40VEM-E	29.0-33.0-36.0
PFFY-P50VEM-E	34.0-37.0-41.0
PFFY-P63VEM-E	32.0-36.0-40.0

5-2. NC curves

PFFY-P20VEM-E

External Static Pressure: 0Pa [0.00in.WG]

Power Source: 220-240V

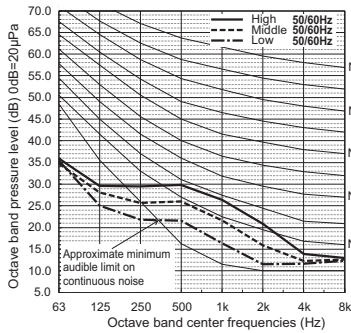

PFFY-P25VEM-E

External Static Pressure: 0Pa [0.00in.WG]

Power Source: 220-240V

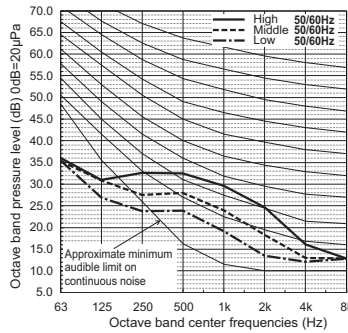

PFFY-P32VEM-E

External Static Pressure: 0Pa [0.00in.WG]

Power Source: 220-240V

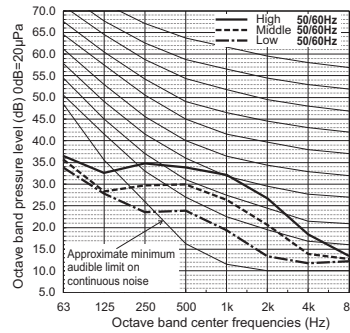

PFFY-P40VEM-E

External Static Pressure: 0Pa [0.00in.WG]

Power Source: 220-240V

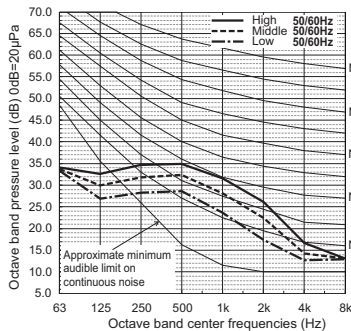

PFFY-P50VEM-E

External Static Pressure: 0Pa [0.00in.WG]

Power Source: 220-240V

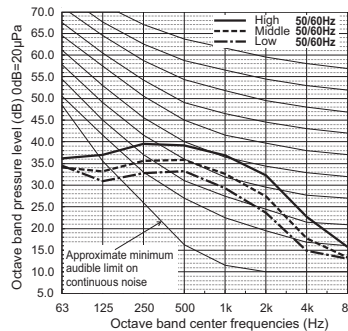

PFFY-P63VEM-E

External Static Pressure: 0Pa [0.00in.WG]

Power Source: 220-240V

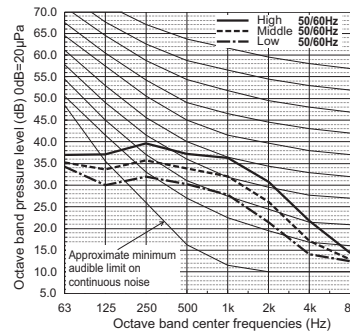

6-1. Temperature distributions

PFFY-P20-63VEM-E

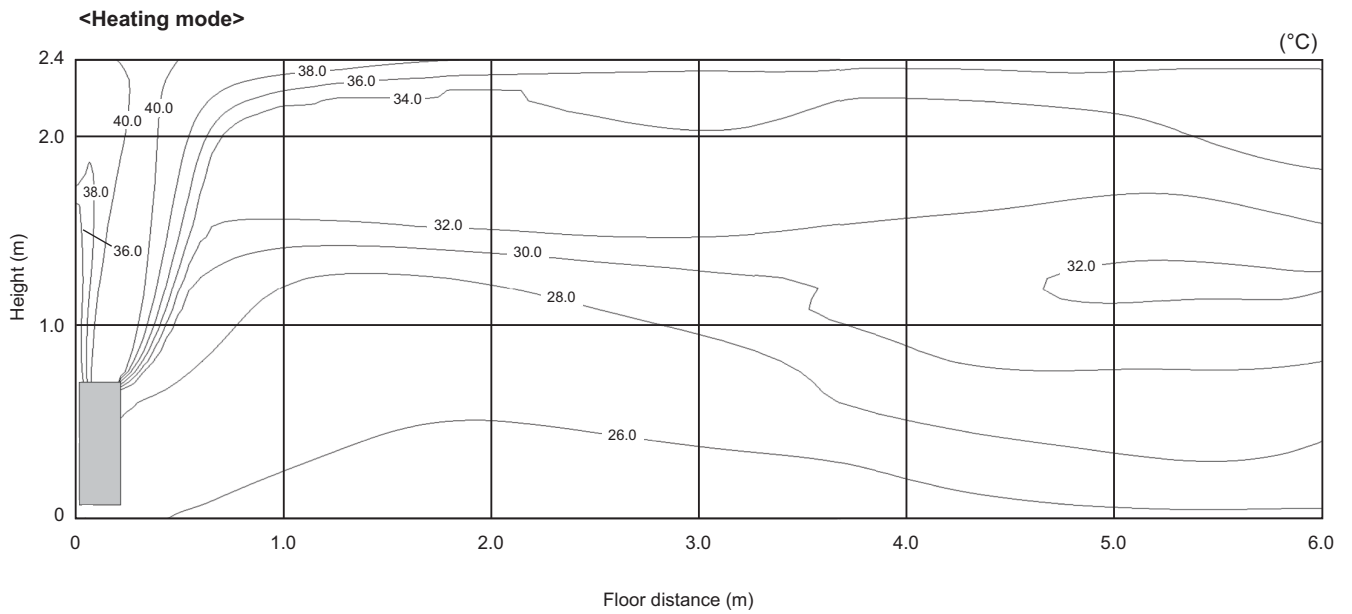
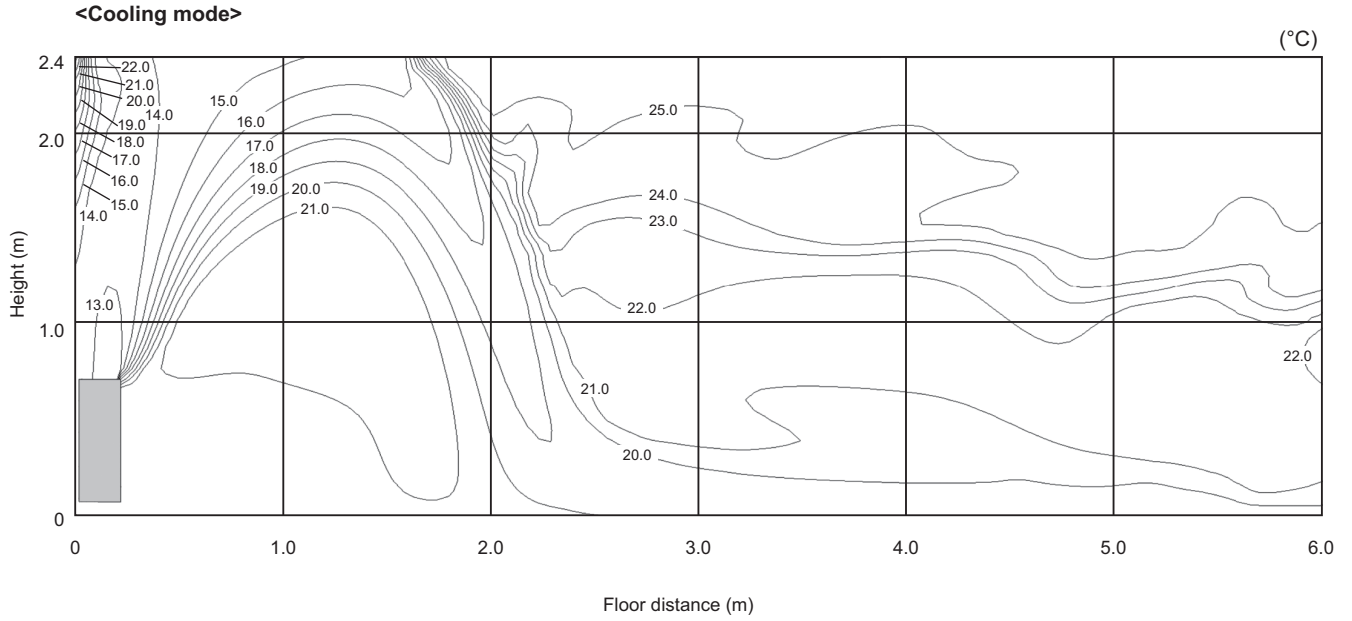

Note : These figures show typical temperature distributions in the conditions above. In the actual installation, the actual temperature distribution may differ from these figures under the influence of air temperature conditions, ceiling height, cooling/heating load, obstacles, etc.

6-2. Airflow distributions

PFFY-P20-63VEM-E

<Cooling mode>

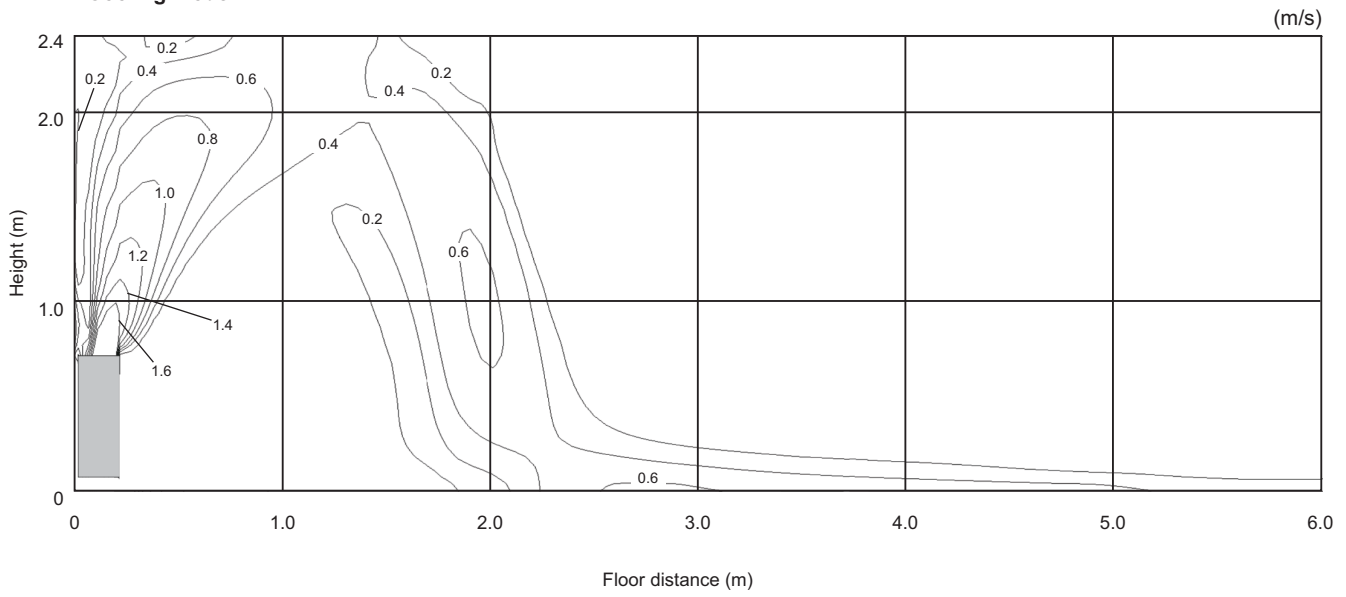

<Heating mode>

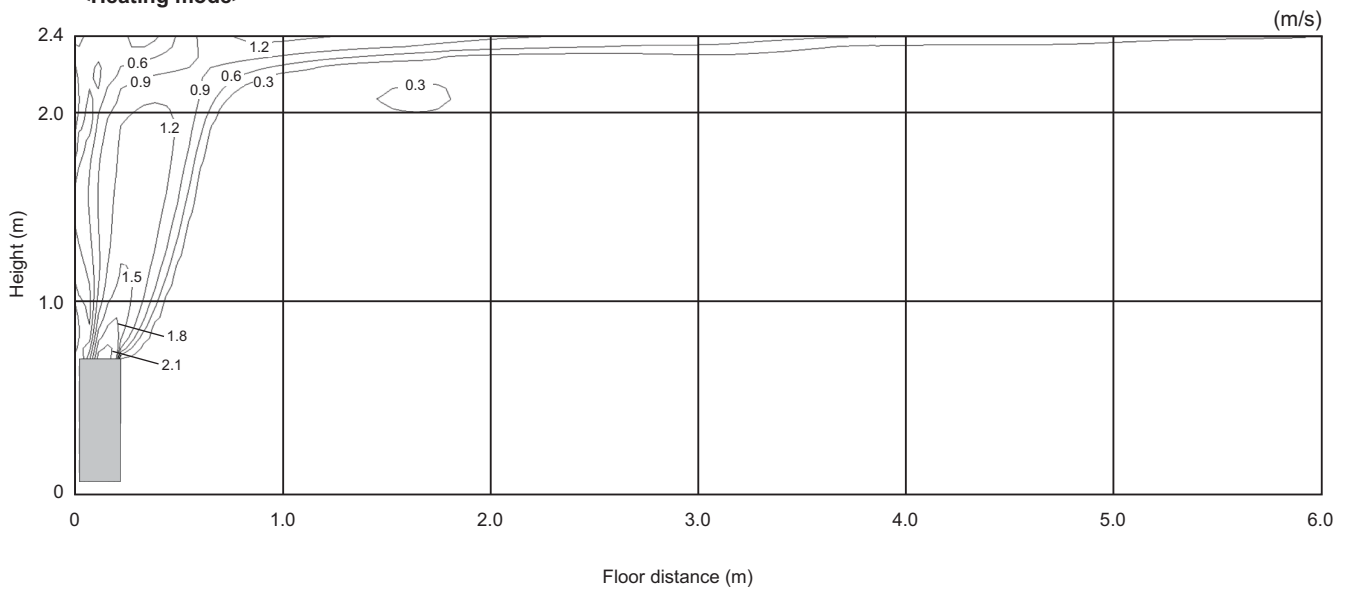

Note : These figures show typical airflow distributions in the conditions above. In the actual installation, the actual airflow distribution may differ from these figures under the influence of air temperature conditions, ceiling height, cooling/heating load, obstacles, etc.

PFFY-P-VEM-E

7. ELECTRICAL CHARACTERISTICS

Floor standing (Exposed type)

Symbols: MCA (Max.Circuit Amps =1.25xFLA), FLA (Full Load Amps)
IFM (Indoor Fan Motor), Output (Fan motor rated output)

Model	Power supply			IFM	
	Volts/Hz	Range +-10%	MCA (A)	Output (kW)	FLA (A)
PFFY-P20VEM-E	220-240V/50Hz 220-240V/60Hz	Max.: 264V Min.: 198V	0.42	0.096	0.33
PFFY-P25VEM-E			0.49	0.096	0.39
PFFY-P32VEM-E			0.55	0.096	0.44
PFFY-P40VEM-E			0.65	0.096	0.52
PFFY-P50VEM-E			0.85	0.096	0.68
PFFY-P63VEM-E			0.82	0.096	0.65

PFFY-P-VEM-E

8-1. Optional parts line up for the Indoor unit

Back decoration panel

PFFY-P20, 25, 32VEM-E
 PFFY-P40, 50VEM-E
 PFFY-P63VEM-E

PAC-BP32VEM-E
 PAC-BP50VEM-E
 PAC-BP63VEM-E

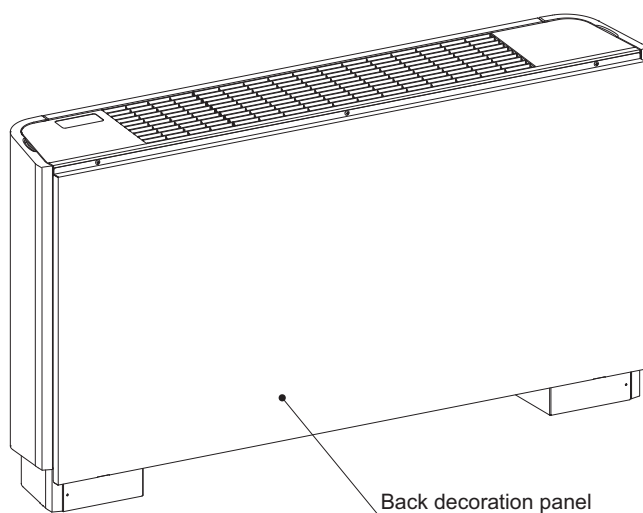

8-2. Back decoration panel

Item	Shape	Quantity	Model name
Back decoration panel		a × b	-
		1098 × 641	1
		1298 × 641	1
		1498 × 641	1
Attachment		2	PAC-BP32•50•63VEM-E
Screw (4x10)		5	PAC-BP32•50•63VEM-E
Installation manual		1	-

Detailed installation information should be referred to its Installation Manual.

⚠ Warning

- Do not use refrigerant other than the type indicated in the manuals provided with the unit and on the nameplate.
 - Doing so may cause the unit or pipes to burst, or result in explosion or fire during use, repair, or at the time of disposal of the unit.
 - It may also be in violation of applicable laws.
 - MITSUBISHI ELECTRIC CORPORATION cannot be held responsible for malfunctions or accidents resulting from the use of the wrong type of refrigerant.
- Our air conditioning equipment and heat pumps contain a fluorinated greenhouse gas, R410A.

mitsubishi **ELECTRIC CORPORATION**

www.MitsubishiElectric.com