



## General dimensions

|       |   |    |
|-------|---|----|
| 6.1   | Dimensions .....                          | 74 |
| 6.1.1 | RAS-(2-3)HVRC3.....                       | 74 |
| 6.1.2 | RAS-(4-6)H(V)(R/N)(C/P)2E.....            | 75 |
| 6.2   | Installation space .....                  | 76 |
| 6.2.1 | Basic sizes .....                         | 76 |
| 6.2.2 | RAS-(2-3)HVRC3.....                       | 77 |
| 6.2.3 | RAS-(4-6)H(V)(R/N)(C/P)2E.....            | 79 |
| 6.2.4 | In the case of stacked installation ..... | 82 |

## 6.1 Dimensions

### 6.1.1 RAS-(2-3)HVRC3

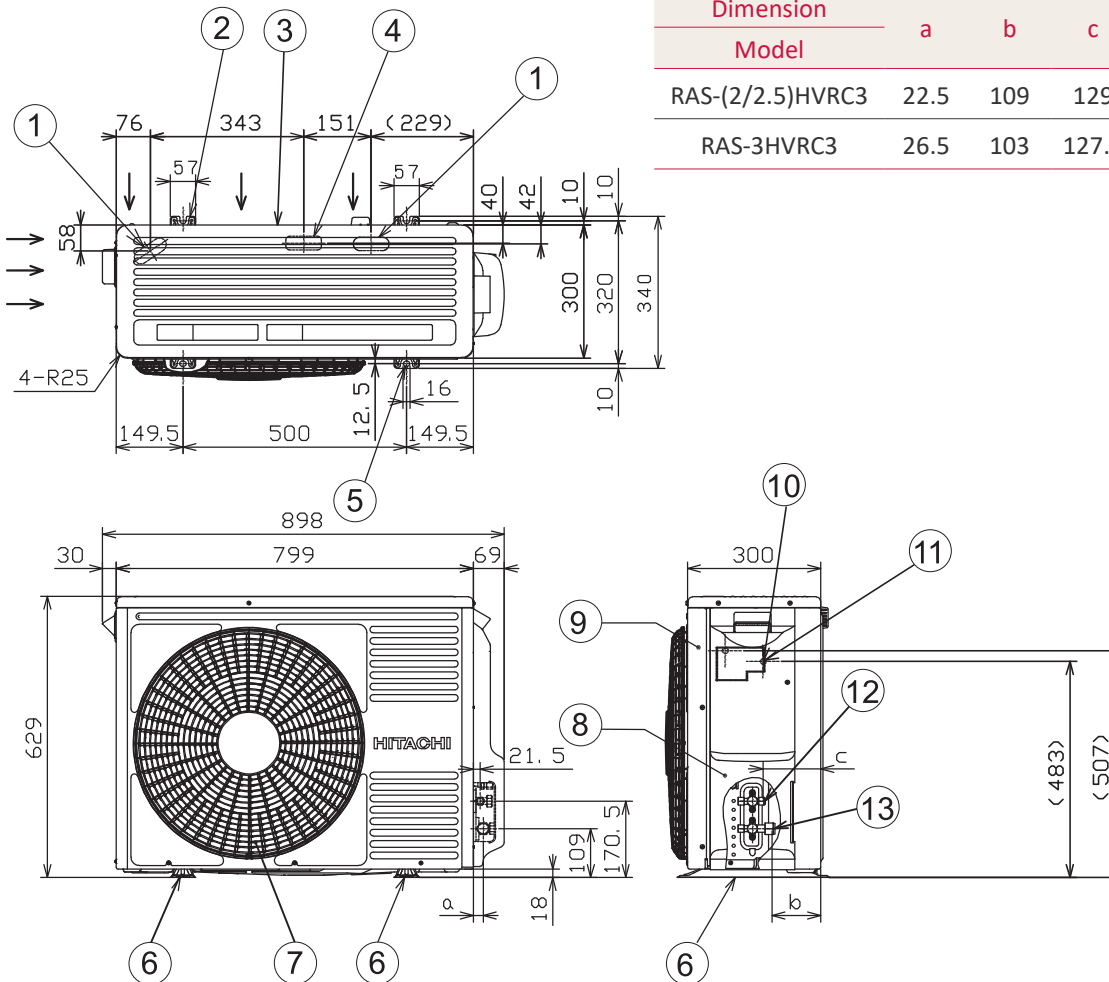

Units in mm.

1. Punched drain hole: 30x80 long hole
2. Attachment hole for M10 anchor bolt: 2-U cut hole
3. Air suction inlet
4. Punched drain hole: For drain pipe
5. Attachment hole for M10 anchor bolt: 2-Long hole
6. Foot part
7. Air discharge outlet
8. Pipe cover
9. Service cover
10. Terminal board for power supply and transmission  
Terminal screw of power supply wire (M5)  
Terminal screw of transmission wire (M4)
11. Terminal screw of earth wire (M5)
12. Connection of refrigerant liquid pipe: with flare nut for  $\varnothing e$  copper pipe
13. Connection of refrigerant gas pipe: With flare nut for  $\varnothing d$  copper pipe

## 6.1.2 RAS-(4-6)H(V)(R/N)(C/P)2E

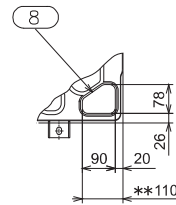
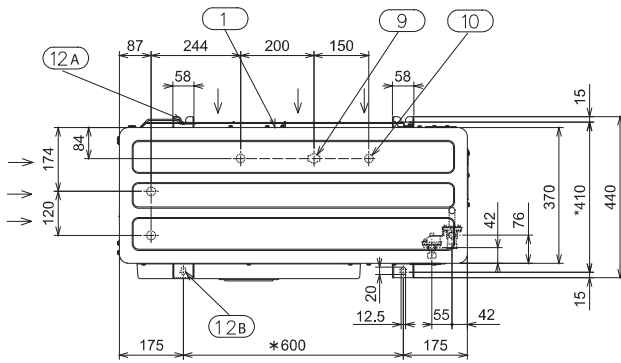

Viewed from A

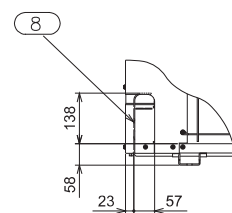
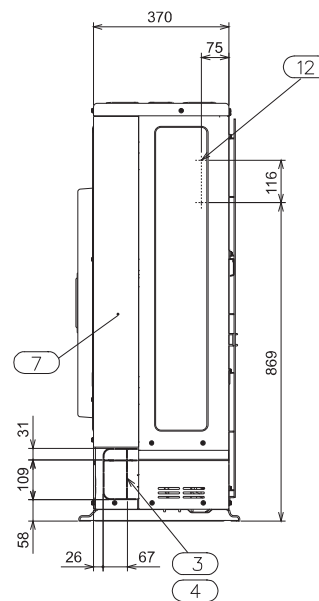
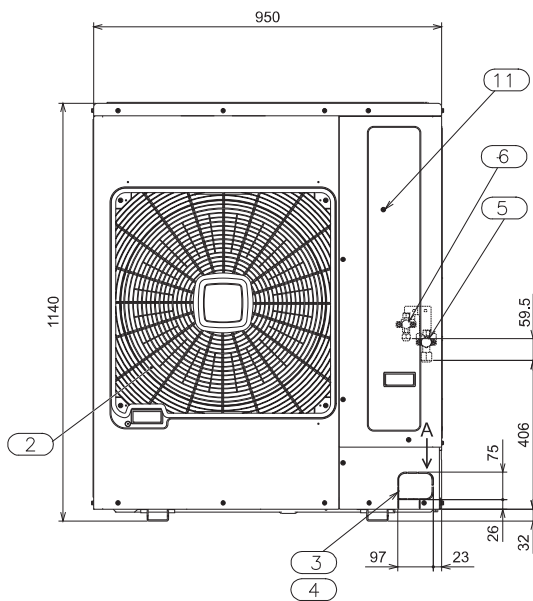

Units in mm.

1. Air inlet
2. Air outlet
3. Holes for power supply wiring
4. Holes for control line wiring
5. Gas piping connection
6. Liquid piping connection
7. Service panel
8. Refrigerant piping hole
9. Drain hole
10. Drain hole
11. Earth terminal wiring: (M5)
12. Holes for fixing machine to wall: A: 2-U cut holes / B: 2 - holes

## 6.2 Installation space

### 6.2.1 Basic sizes

#### ◆ RAS-(2-3)HVRC3

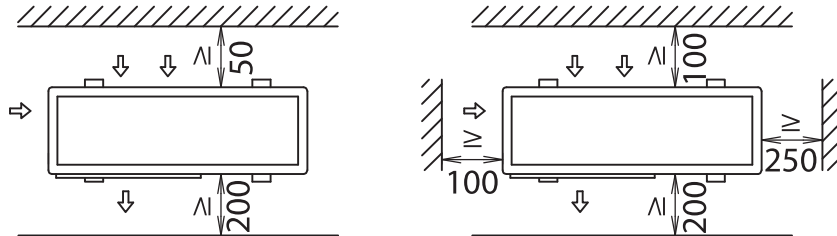

Units in mm.

#### ◆ RAS-(4-6)H(V)(R/N)(C/P)2E

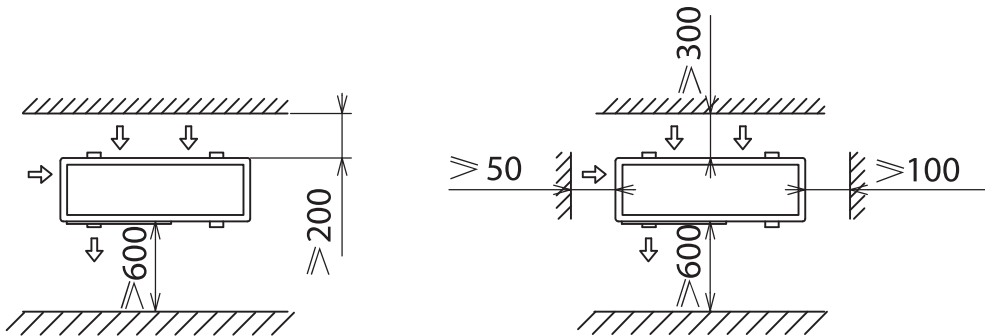

Units in mm.

#### **i** NOTE

Please refer to the Service Manual for specific information.

## 6.2.2 RAS-(2-3)HVRC3

(Unit: mm)

### a) In case the front side and either of the sides are open (single unit)

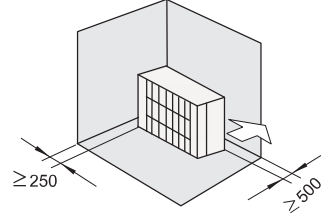
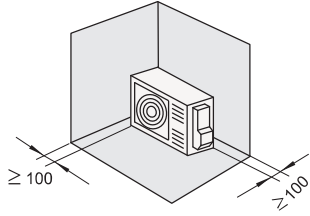

### b) In case that a surrounding wall exists (single unit)

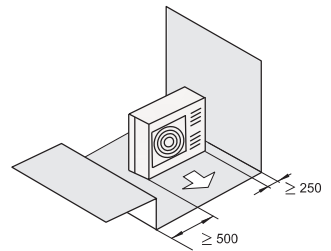
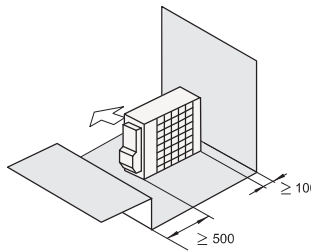
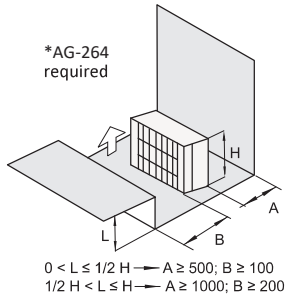
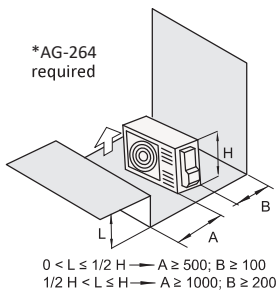

### c) In case that upper side obstacles exist (single unit)

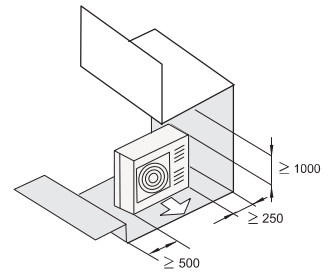
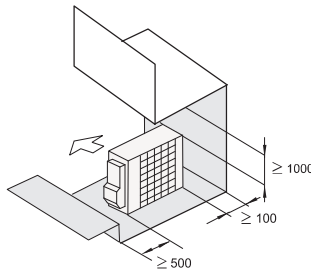
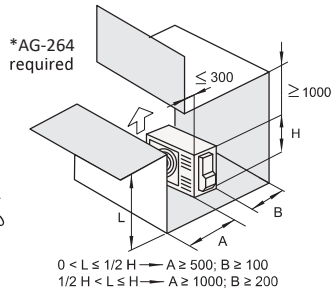
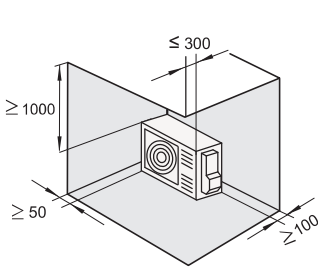

### d) In case that upper side obstacles exist (serial units)

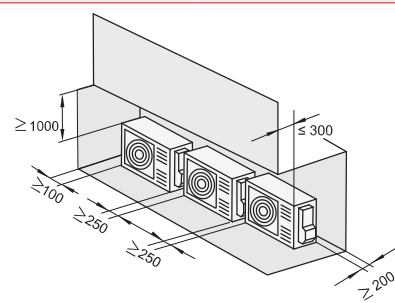
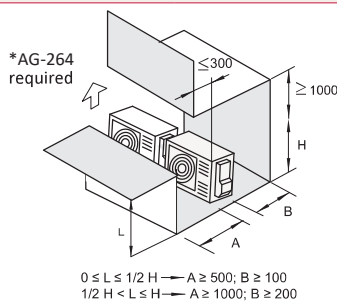

### e) In case the front side and either of the sides are open (serial units)

### f) In case that the surrounding walls exist (serial units)

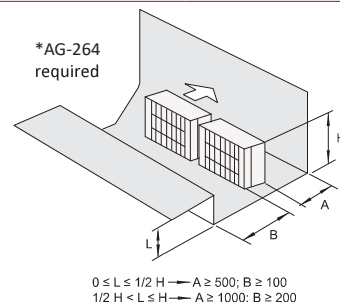
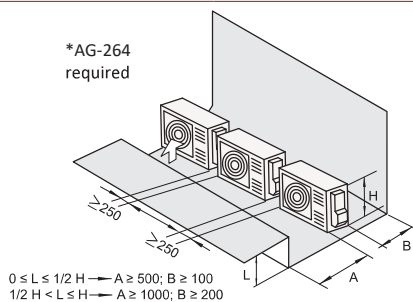

## g) Horizontal (multiple units)

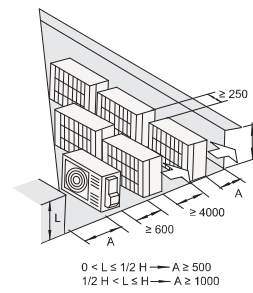
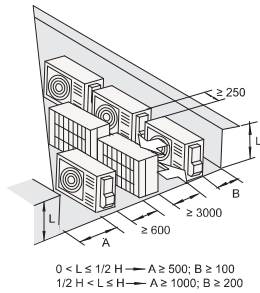

## h) Vertical (multiple units)

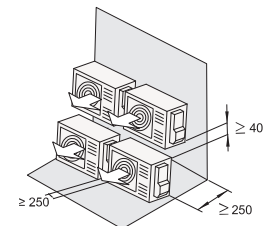
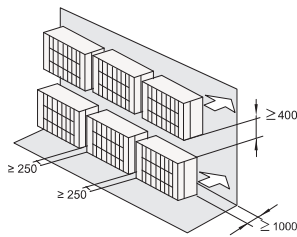

Do not stack more than two units in height. - Close gap (\*) to avoid recirculating discharge air flow.

When  $L > H$  use a base for outdoor unit to make  $L \leq H$ . Close the base not to allow the outlet air bypassed.

### ◆ Location and strong wind considerations

Follow the instructions to install on the rooftop or a location without surrounding buildings, where strong wind is expected against the product.

Choose a location where the outlet or inlet side of the product will not be exposed to strong wind.

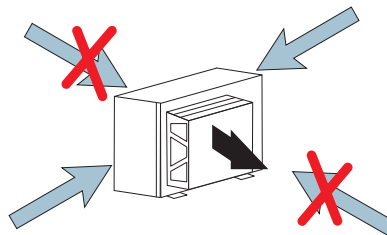

Strong direct winds may cause lack of air flow and negatively impact the operation of the unit. Excessive strong wind against the outdoor unit's air outlet side can lead to reverse rotation, potentially damaging the fan and motor. In that case, the wind guard (sold separately as accessory) must be installed.

### **i** NOTE

- When the wind guard is installed must be set DSW2 pin 3 = ON.
- For ambient temperature  $\leq 10$  °C, it is recommended to set the wind guard if cooling operation is to be used.

## 6.2.3 RAS-(4-6)H(V)(R/N)(C/P)2E

(Unit: mm)

### Blocked in Inlet Side

#### Upper Side Open

##### Single Installation

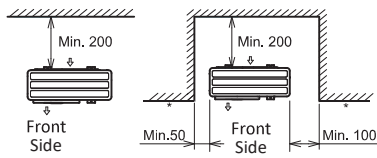

##### Multiple Installation (Two units or more)

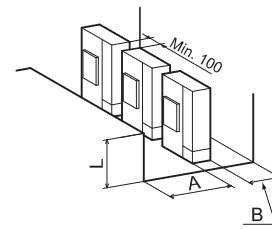
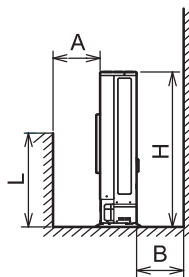
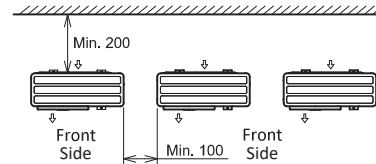

#### Upper Side Blocked

##### Single Installation

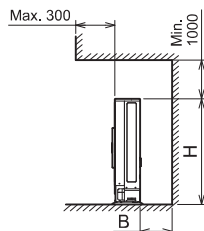

##### Multiple Installation (Two units or more)

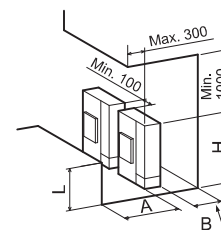
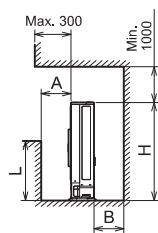
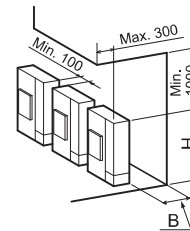

## Outlet Side Blocked

### Upper Side Open

Single Installation

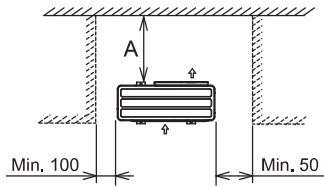

Multiple Installation (Two units or more)

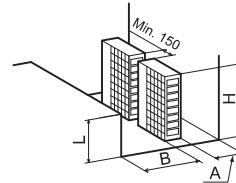
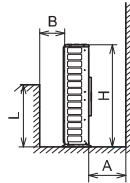
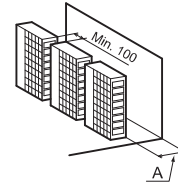

## Right and Left Blocked

### Upper Side Open

Single Installation

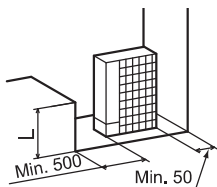

### Upper Side Blocked

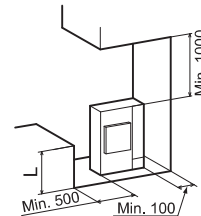
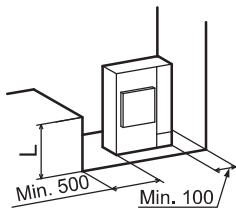
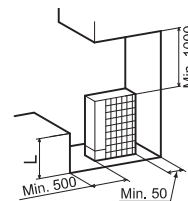

## Multi-Row and Multiple Installations

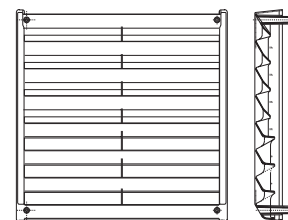
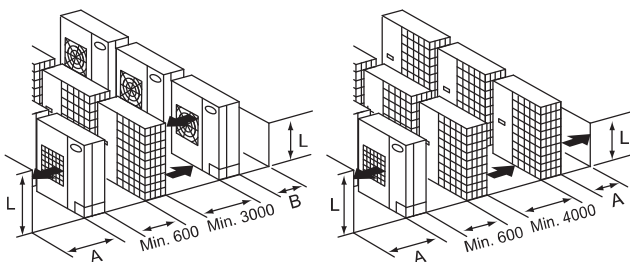

Mount the airflow guide and provide sufficient space on both right and left sides.

When using airflow guide (AG-335A, optional), check that the discharged air is not short-circuited to the air inlet side.

**A**

**B**

$0 < L \leq 1/2H$     $1/2H < L \leq H$     $0 < L \leq 1/2H$     $1/2H < L \leq H$

Min. 600   Min. 1400   Min. 300   Min. 350

When  $L > H$  use a base for outdoor unit to make  $L \leq H$ . Close the base not to allow the outlet air bypassed.



## ◆ Location and strong wind considerations

Follow the instructions to install on the rooftop or a location without surrounding buildings, where strong wind is expected against the product.

Choose a location where the outlet or inlet side of the product will not be exposed to strong wind.

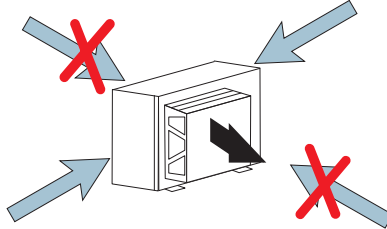

Strong direct winds may cause lack of air flow and negatively impact the operation of the unit. Excessive strong wind against the outdoor unit's air outlet side can lead to reverse rotation, potentially damaging the fan and motor. In that case, the wind guard (sold separately as accessory) must be installed.

## 6.2.4 In the case of stacked installation

Please stack up to two levels

Block part A to prevent the blown air from bypassing. Install so that the drain water from the upper unit does not come into contact with the lower unit.

### ◆ RAS-(2-3)HVRC3

#### Stack in one column

Blocked in Inlet Side

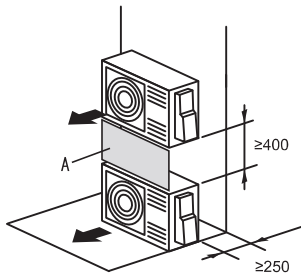

Outlet Side Blocked

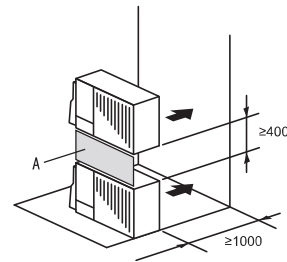

Air flow guide must be installed

#### Stacks in two or more column

Blocked in Inlet Side

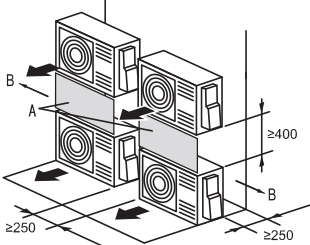

Install up to 2 columns (2 units horizontally) and leave both sides open (part B)

Outlet Side Blocked

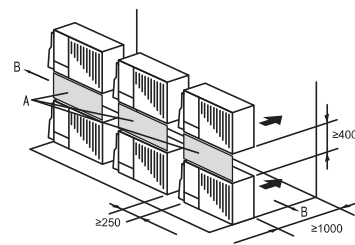

Air flow guide must be installed and leave both sides open (part B)

## ◆ RAS-(4-6)H(V)(R/N)(C/P)2E

### Stack in one column

Blocked in Inlet Side

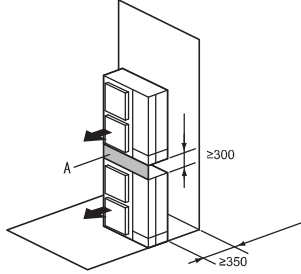

Outlet Side Blocked

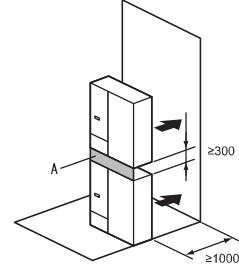

Air flow guide must be installed

### Stacks in two or more column

Blocked in Inlet Side

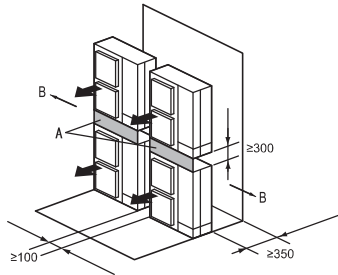

Install up to 2 columns (2 units horizontally) and leave both sides open (part B)

Outlet Side Blocked

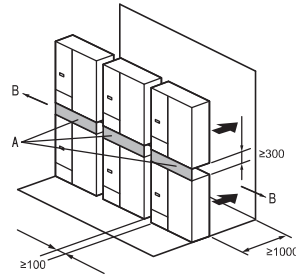

Air flow guide must be installed and leave both sides open (part B)