

HOT WATER HEAT PUMP

**2018**  
**R744**

# Service Handbook



Model

**QAHV-N560YA-HPB**

**2nd edition**

# Safety Precautions

- Thoroughly read the following safety precautions prior to use.
- Observe these precautions carefully to ensure safety.

 <b>WARNING</b>	Indicates a risk of death or serious injury
 <b>CAUTION</b>	Indicates a risk of injury or structural damage
 <b>IMPORTANT</b>	Indicates a risk of damage to the unit or other components in the system

**All electric work must be performed by personnel certified by Mitsubishi Electric.**

## General

### **WARNING**

**Do not use refrigerant other than the type indicated in the manuals provided with the unit and on the nameplate.**

- Doing so may cause the unit or pipes to burst, or result in explosion or fire during use, during repair, or at the time of disposal of the unit.
- It may also be in violation of applicable laws.
- MITSUBISHI ELECTRIC CORPORATION cannot be held responsible for malfunctions or accidents resulting from the use of the wrong type of refrigerant.

**Do not install the unit in a place where large amounts of oil, steam, organic solvents, or corrosive gases, such as sulfuric gas, are present or where acidic/alkaline solutions or sprays containing sulfur are used frequently.**

These substances can compromise the performance of the unit or cause certain components of the unit to corrode, which can result in refrigerant leakage, water leakage, injury, electric shock, malfunctions, smoke, or fire.

**Do not try to defeat the safety features of the unit or make unauthorized setting changes.**

Forcing the unit to operate the unit by defeating the safety features of the devices such as the pressure switch or the temperature switch, making unauthorized changes to the switch settings, or using accessories other than the ones recommended by Mitsubishi Electric may result in smoke, fire, or explosion.

To reduce the risk of fire or explosion, do not use volatile or flammable substances as a heat carrier.

To reduce the risk of burns or electric shock, do not touch exposed pipes and wires.

To reduce the risk of shorting, current leakage, electric shock, malfunctions, smoke, or fire, do not splash water on electric parts.

To reduce the risk of electric shock, malfunctions, smoke or fire, do not operate the switches/buttons or touch other electrical parts with wet hands.

To reduce the risk of electric shock and injury from the fan or other rotating parts, stop the operation and turn off the main power before cleaning, maintaining, or inspecting the unit.

To reduce the risk of burns or frost bites, do not touch the refrigerant pipes or refrigerant circuit components with bare hands during and immediately after operation.

Before cleaning the unit, switch off the power. (Unplug the unit, if it is plugged in.)

To reduce the risk of injury, keep children away while installing, inspecting, or repairing the unit.

Children should be supervised to ensure that they do not play with the appliance.

This appliance is not intended for use by persons (including children) with reduced physical, sensory or mental capabilities, or lack of experience and knowledge, unless they have been given supervision or instruction concerning use of the appliance by a person responsible for their safety.

**Keep the space well ventilated. Refrigerant can displace air and cause oxygen starvation.**

If leaked refrigerant comes in contact with a heat source, toxic gas may be generated.

**Always replace a fuse with one with the correct current rating.**

The use of improperly rated fuses or a substitution of fuses with steel or copper wire may result in fire or explosion.

**If any abnormality (e.g., burning smell) is noticed, stop the operation, turn off the power switch, and consult your dealer.**

Continuing the operation may result in electric shock, malfunctions, or fire.

**Properly install all required covers and panels on the terminal box and control box to keep moisture and dust out.**

Dust accumulation and water may result in electric shock, smoke, or fire.

**Consult an authorized agency for the proper disposal of the unit**

Refrigerant oil and refrigerant that may be left in the unit pose a risk of fire, explosion, or environmental pollution.

### **CAUTION**

To reduce the risk of fire or explosion, do not place flammable materials or use flammable sprays around the unit.

Do not operate the unit without panels and safety guards properly installed.

To reduce the risk of injury, do not sit, stand, or place objects on the unit.
<b>Do not connect the makeup water pipe directly to the potable water pipe. Use a cistern tank between them.</b>
Connecting these pipes directly may cause the water in the unit to migrate into the potable water and cause health problems.
To reduce the risk of adverse effects on plants and animals, do not place them where they are directly exposed to discharge air from the unit.
<b>Do not install the unit on or over things that are vulnerable to water damage.</b>
Condensation may drip from the unit.
The model of heat pump unit described in this manual is not intended for use to preserve food, animals, plants, precision instruments, or art work.
To reduce the risk of injury, do not touch the heat exchanger fins or sharp edges of components with bare hands.
<b>Do not place a container filled with water on the unit.</b>
If water spills on the unit, it may result in shorting, current leakage, electric shock, malfunction, smoke, or fire.
<b>Always wear protective gears when touching electrical components on the unit.</b>
Several minutes after the power is switched off, residual voltage may still cause electric shock.
To reduce the risk of injury, do not insert fingers or foreign objects into air inlet/outlet grills.
To reduce the risk of injury, wear protective gear when working on the unit.
<b>Do not release refrigerant into the atmosphere. Collect and reuse the refrigerant, or have it properly disposed of by an authorized agency.</b>
Refrigerant poses environmental hazards if released into the air.

<b>To prevent environmental pollution, dispose of brine in the unit and cleaning solutions according to the local regulations.</b>
It is punishable by law not to dispose of them according to the applicable laws.
<b>The water heated by the heat pump is not suitable for use as drinking water or for cooking.</b>
It may cause health problems or degrade food.
<b>In areas where temperature drops to freezing during the periods of non-use, blow the water out of the pipes or fill the pipes with anti-freeze solution.</b>
Not doing so may cause the water to freeze, resulting in burst pipes and damage to the unit or the furnishings.
In areas where temperature drops to freezing, use an anti-freeze circuit and leave the main power turned on to prevent the water in the water circuit from freezing and damaging the unit or causing water leakage and resultant damage to the furnishings.
<b>Use clean tap water.</b>
The use of acidic or alkaline water or water high in chlorine may corrode the unit or the pipes, causing water leakage and resultant damage to the furnishings.
<b>In areas where temperature can drop low enough to cause the water in the pipes to freeze, operate the unit often enough to prevent the water from freezing.</b>
Frozen water in the water circuit may cause the water to freeze, resulting in burst pipes and damage to the unit or the furnishings.
<b>Periodically inspect and clean the water circuit.</b>
Dirty water circuit may compromise the unit's performance or corrodes the unit or cause water leakage and resultant damage to the furnishings.

## Transportation

### WARNING

<b>Lift the unit by placing the slings at designated locations. Support the outdoor unit securely at four points to keep it from slipping and sliding.</b>
If the unit is not properly supported, it may fall and cause personal injury.

### CAUTION

To reduce the risk of injury, do not carry the product by the PP bands that are used on some packages.
--

To reduce the risk of injury, products weighing 20 kg or more should be carried by two or more people.
--

## Installation

### WARNING

<b>Do not install the unit where there is a risk of leaking flammable gas.</b>
If flammable gas accumulates around the unit, it may ignite and cause a fire or explosion.

<b>Properly dispose of the packing materials.</b>
Plastic bags pose suffocation hazard to children.

**The unit should be installed only by personnel certified by Mitsubishi Electric according to the instructions detailed in the Installation/Operation Manual.**

Improper installation may result in refrigerant leakage, water leakage, injury, electric shock, or fire.

**Periodically check the installation base for damage.**

If the unit is left on a damaged base, it may fall and cause injury.

**Remove packing materials from the unit before operating the unit. Note that some accessories may be taped to the unit. Properly install all accessories that are required.**

Failing to remove the packing materials or failing to install required accessories may result in refrigerant leakage, oxygen starvation, smoke, or fire.

Consult your dealer and take appropriate measures to safeguard against refrigerant leakage and resultant oxygen starvation. An installation of a refrigerant gas detector is recommended.

 **CAUTION**

**Do not install the unit on or over things that are vulnerable to water damage.**

When the indoor humidity exceeds 80% or if the drain water outlet becomes clogged, condensation may drip from the indoor unit onto the ceiling or floor.

Any additional parts must be installed by qualified personnel. Only use the parts specified by Mitsubishi Electric.

Take appropriate safety measures against wind gusts and earthquakes to prevent the unit from toppling over and causing injury.

**Be sure to install the unit horizontally, using a level.**

If the unit is installed at an angle, it may fall and cause injury or cause water leakage.

The unit should be installed on a surface that is strong enough to support its weight.

**As an anti-freeze, use ethylene glycol or propylene glycol diluted to the specified concentration.**

The use of other types of anti-freeze solution may cause corrosion and resultant water leakage. The use of flammable anti-freeze may cause fire or explosion.

**All drainage work should be performed by the dealer or qualified personnel according to the instructions detailed in the Installation Manual.**

Improper drainage work may cause rain water or drain water to enter the buildings and damage the furnishings.

## Pipe installation

 **WARNING**

To prevent explosion, do not heat the unit with refrigerant gas in the refrigerant circuit.

**Check for refrigerant leakage at the completion of installation.**

If leaked refrigerant comes in contact with a heat source, toxic gas may be generated.

 **CAUTION**

**Check that no substance other than the specified refrigerant (R744) is present in the refrigerant circuit.**

Infiltration of other substances may cause the pressure to rise abnormally high and cause the pipes to explode.

To keep the ceiling and floor from getting wet due to condensation, properly insulate the pipes.

**Piping work should be performed by the dealer or qualified personnel according to the instructions detailed in the Installation Manual.**

Improper piping work may cause water leakage and damage the furnishings.

## Electrical wiring

To reduce the risk of wire breakage, overheating, smoke, and fire, keep undue force from being applied to the wires.

**Properly secure the cables in place and provide adequate slack in the cables so as not to stress the terminals.**

Improperly connected cables may break, overheat, and cause smoke or fire.

To reduce the risk of injury or electric shock, switch off the main power before performing electrical work.

**All electric work must be performed by a qualified electrician according to the local regulations, standards, and the instructions detailed in the Installation Manual.**

Capacity shortage to the power supply circuit or improper installation may result in malfunction, electric shock, smoke, or fire.

To reduce the risk of electric shock, smoke, or fire, install an inverter circuit breaker on the power supply to each unit.

**Use properly rated breakers and fuses (inverter breaker, Local Switch <Switch + Type-B fuse>, or no-fuse breaker).**

The use of improperly rated breakers may result in malfunctions or fire.



To reduce the risk of current leakage, overheating, smoke, or fire, use properly rated cables with adequate current carrying capacity.

**Keep the unsheathed part of cables inside the terminal block.**

If unsheathed part of the cables come in contact with each other, electric shock, smoke, or fire may result.

 **CAUTION**

To reduce the risk of current leakage, wire breakage, smoke, or fire, keep the wiring out of contact with the refrigerant pipes and other parts, especially sharp edges.

**Proper grounding must be provided by a licensed electrician. Do not connect the grounding wire to a gas pipe, water pipe, lightning rod, or telephone wire.**

Improper grounding may result in electric shock, smoke, fire, or malfunction due to electrical noise interference.

To reduce the risk of electric shock, shorting, or malfunctions, keep wire pieces and sheath shavings out of the terminal block.

## Transportation and repairs

 **WARNING**

**The unit should be moved, disassembled, or repaired only by qualified personnel. Do not alter or modify the unit.**

Improper repair or unauthorized modifications may result in refrigerant leakage, water leakage, injury, electric shock, or fire.

**After disassembling the unit or making repairs, replace all components as they were.**

Failing to replace all components may result in injury, electric shock, or fire.

If the supply cord is damaged, it must be replaced by the manufacturer, its service agent or similarly qualified persons in order to avoid a hazard.

 **CAUTION**

To reduce the risk of shorting, electric shock, fire, or malfunction, do not touch the circuit board with tools or with your hands, and do not allow dust to accumulate on the circuit board.

## IMPORTANT

To avoid damage to the unit, use appropriate tools to install, inspect, or repair the unit.

To reduce the risk of malfunction, turn on the power at least 12 hours before starting operation, and leave the power turned on throughout the operating season.

**Recover all refrigerant from the unit.**

It is punishable by law to release refrigerant into the atmosphere.

**Do not unnecessarily change the switch settings or touch other parts in the refrigerant circuit.**

Doing so may change the operation mode or damage the unit.

To reduce the risk of malfunctions, use the unit within its operating range.

**Do not switch on or off the main power in a cycle of shorter than 10 minutes.**

Short-cycling the compressor may damage the compressor.

To maintain optimum performance and reduce the risk of malfunction, keep the air pathway clear.

**To ensure proper operation of the unit, periodically check for proper concentration of anti-freeze.**

Inadequate concentration of anti-freeze may compromise the performance of the unit or cause the unit to abnormally stop.

**Take appropriate measures against electrical noise interference when installing the air conditioners in hospitals or facilities with radio communication capabilities.**

Inverter, high-frequency medical, or wireless communication equipment as well as power generators may cause the air conditioning system to malfunction. Air conditioning system may also adversely affect the operation of these types of equipment by creating electrical noise.

**Check the water system, using a relevant manual as a reference.**

Using the system that does not meet the standards (including water quality and water flow rate) may cause the water pipes to corrode.

To reduce the risk of power capacity shortage, always use a dedicated power supply circuit.

This appliance is intended to be used by expert or trained users in shops, in light industry and on farms, or for commercial use by lay persons.

# CONTENTS

---

## I Read Before Servicing

[1] Read Before Servicing .....	3
[2] Necessary Tools and Materials .....	4
[3] Brazing .....	5
[4] Procedure .....	6
[5] CO2 refrigerant manifold structure .....	11
[6] Characteristics of the Conventional and the New Refrigerants .....	12
[7] Notes on Refrigerating Machine Oil .....	13

## II Restrictions

[1] System Configuration .....	17
[2] Types and Maximum allowable Length of Cables .....	18
[3] Main Power Supply Wiring and Switch Capacity .....	19
[4] Sample Installation .....	23
[5] Switch Types and the Factory Settings .....	24
[6] Configuring the Settings .....	25
[7] Water Pipe Installation .....	33
[8] Using the Unit in Sub-freezing or Snowy Conditions .....	37
[9] Secondary side control system .....	38

## III Unit Components

[1] Unit Components and Refrigerant Circuit .....	47
[2] Control Box of the Unit .....	50
[3] Unit Circuit Board .....	52

## IV Remote Controller

[1] Using the Remote Controller .....	59
---------------------------------------	----

## V Electrical Wiring Diagram

[1] Electrical Wiring Diagram .....	73
-------------------------------------	----

## VI Refrigerant Circuit

[1] Refrigerant Circuit Diagram .....	79
[2] Principal Parts and Functions .....	80

## VII Control

[1] Functions and Factory Settings of the Dip switches .....	85
[2] Operating characteristics and Control Capabilities .....	105

## VIII Test Run Mode

[1] Items to be checked before a Test Run .....	115
[2] Operating the Unit .....	117
[3] Refrigerant .....	118
[4] Standard operating characteristics (Reference data) .....	118

## IX Troubleshooting

[1] Maintenance items .....	121
[2] Troubleshooting .....	126
[3] Troubleshooting Principal Parts .....	136
[4] Refrigerant Leak .....	152
[5] Parts Replacement Procedures .....	153
[6] Removing scale from the gas cooler .....	159

## X Attachments

[1] R744 refrigerant saturation temperature table .....	167
---	-----

# CONTENTS

---

---

## I Read Before Servicing

[1] Read Before Servicing .....	3
[2] Necessary Tools and Materials.....	4
[3] Brazing.....	5
[4] Procedure .....	6
[5] CO2 refrigerant manifold structure.....	11
[6] Characteristics of the Conventional and the New Refrigerants .....	12
[7] Notes on Refrigerating Machine Oil.....	13



## **[1] Read Before Servicing**

---

**1. Check the type of refrigerant used in the system to be serviced.**

**Refrigerant Type**

Hot water Heat pump QAHV-N560YA-HPB:R744

**2. Check the symptoms exhibited by the unit to be serviced.**

Refer to this service handbook for symptoms relating to the refrigerant cycle.

**3. Thoroughly read the safety precautions at the beginning of this manual.**

**4. Preparing necessary tools: Prepare a set of tools to be used exclusively with each type of refrigerant.**

Refer to "Necessary Tools and Materials" for information on the use of tools.(page 4)

**5. If there is a leak of gaseous refrigerant and the remaining refrigerant is exposed to an open flame, a poisonous gas may form. Keep workplace well ventilated.**



**CAUTION**

- Install new pipes immediately after removing old ones to keep moisture out of the refrigerant circuit.
- The use of refrigerant that contains chloride, such as R22, will cause the refrigerating machine oil to deteriorate.

---

## [2] Necessary Tools and Materials

---

Prepare the following tools and materials necessary for servicing the unit.

### Replacement procedures for refrigerant circuit components

Preparation

#### 1. Tools required

##### (1) Special tools for use with CO<sub>2</sub> refrigerant

- 1) Manifold: Withstand pressure of 21 MPa (Maximum unit pressure: 14 MPa)
- 2) Refrigerant charging hose (Withstand pressure: maximum unit pressure of 14 MPa); Unit connection: Swagelok (7/16-20UNF)
- 3) Pipe cutter: One capable of thick-wall pipe
- 4) CO<sub>2</sub> refrigerant (Two 7 Kg cylinders)
- 5) Mouthpiece for CO<sub>2</sub> refrigerant

##### (2) Other tools

- 1) Welder (Welder nozzle #250 or greater)
- 2) Packless valve: for checking the degree of vacuum
- 3) VaVacuum pump (with a check valve or an adapter) cuuming hose (for R404A/R407C); Unit connection: Swagelok (7/16-20UNF)
- 4) Vacuum pump (with a check valve or an adapter)
- 5) Nitrogen (pressure reductin valve): for gas leak check, for non-oxidizing welding → Pressure reduction valve that can be adjusted to the pressure of 8.5 MPa
- 6) Scale: for controlling refrigerant charge
- 7) General tools for replacing parts (screwdriver, etc.)
- 8) Gas leak test liquid (foam test)

#### 2. Replacement workflow

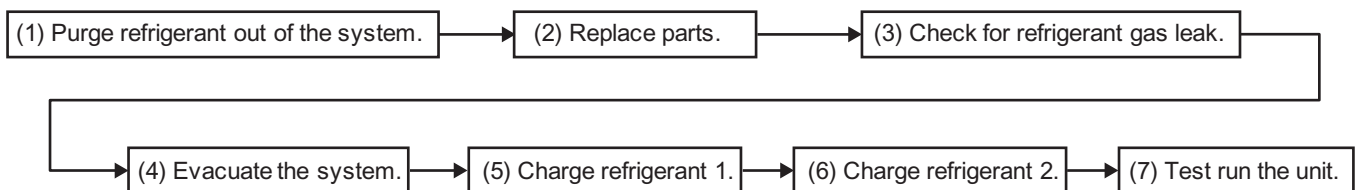



### [3] Brazing

No changes have been made in the brazing procedures. Perform brazing with special care to keep foreign objects (such as oxide scale, water, and dust) out of the refrigerant system.

Example: Inside the brazed connection

Use of oxidized solder for brazing

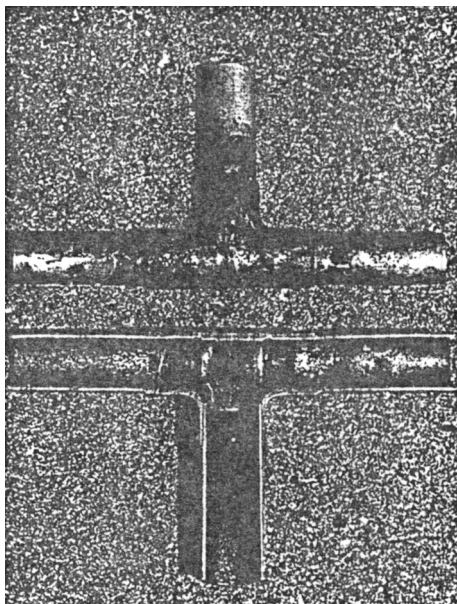

Use of non-oxidized solder for brazing

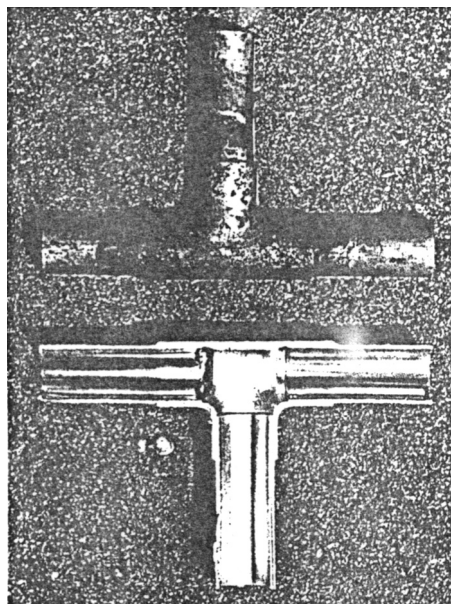

#### 1. Items to be strictly observed

- Do not conduct refrigerant piping work outdoors if raining.
- Use non-oxidized solder.
- Use a brazing material (BCuP-3) that requires no flux when brazing between copper pipes or between a copper pipe and copper coupling.
- If installed refrigerant pipes are not immediately connected to the equipment, then braze and seal both ends.

#### 2. Reasons

- The new refrigerating machine oil is 10 times as hygroscopic as the conventional oil and is more likely to cause unit failure if water infiltrates into the system.
- Flux generally contains chloride. Residual flux in the refrigerant circuit will cause sludge to form.

#### 3. Notes

Do not use commercially available antioxidants because they may cause the pipes to corrode or refrigerating machine oil to deteriorate.

**[4] Procedure**

**(1) Refrigerant purging**

No.	Procedure	Cautionary notes
1	Make sure the high- and low-pressure service valves are closed all the way.	If the valves are open, there is a risk of refrigerant gushing out when the sealing caps are removed.
2	Remove the sealing caps from the high- and low-pressure service joints.	Use caution because a small amount of refrigerant may gush out.
3	Slowly open the high- and low-pressure service valves. Open the valves to the point where water drips form on the pipes (without freezing).	Be sure to open the valves slowly. Opening the valves too quickly may cause dry ice to form at the release port, which may trap the refrigerant in the unit or cause a large amount of refrigerant oil to come out. If no refrigerant oil is coming out, heating the release port can reduce the CO <sub>2</sub> release time. Make sure the released CO <sub>2</sub> will not accumulate around the work area and cause oxygen starvation.

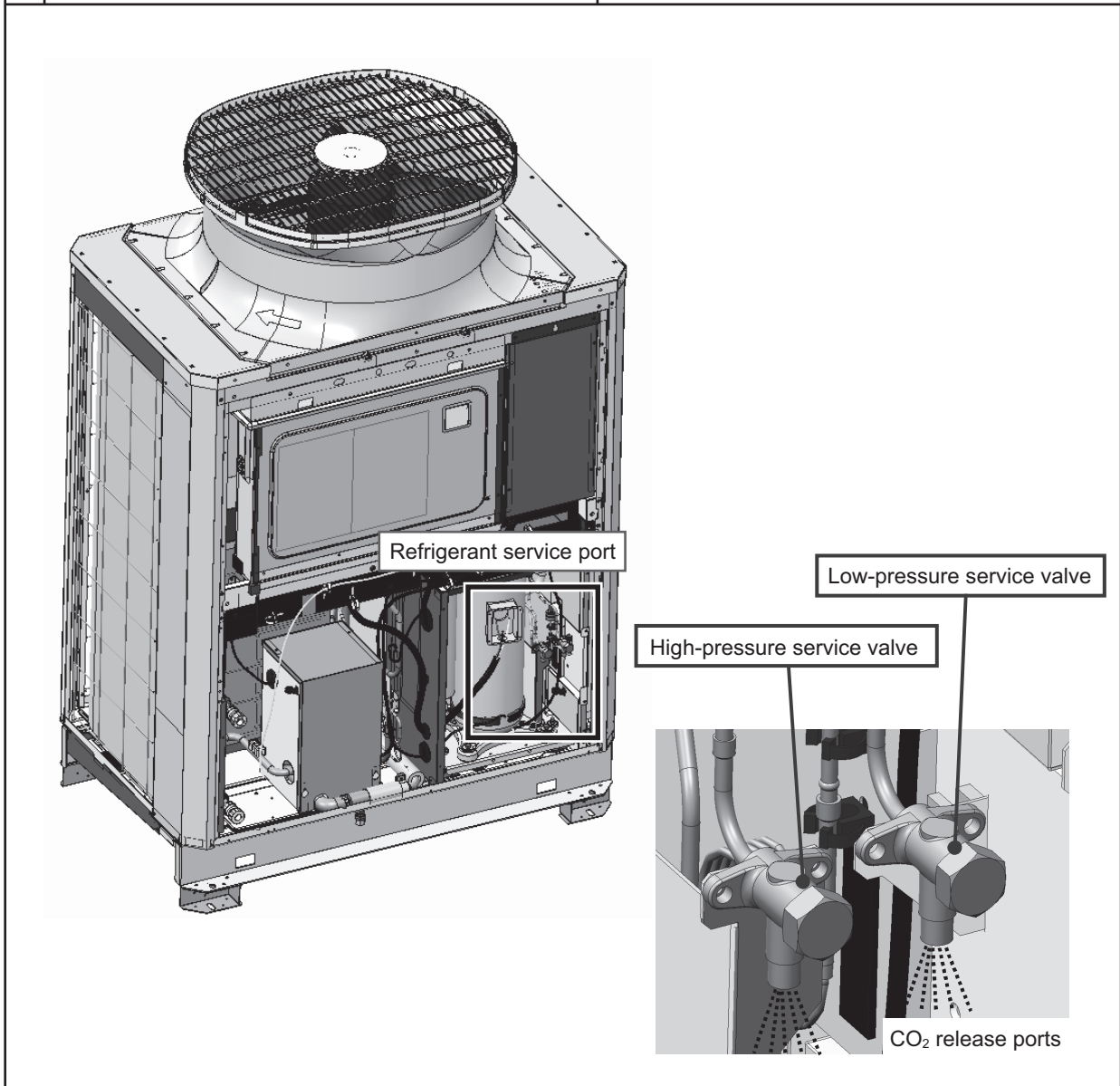

**(2) Parts replacement**

No.	Procedure	Cautionary notes
1	Using a pipe cutter, cut a slit in the pipe on the side of the unit where parts are replaced to ensure an absence of pressure in the pipe.	Residual pressure in the pipe can pose safety hazards.
2	Connect a nitrogen cylinder to purge the refrigerant circuit at a pressure of 0.05 MPa.	Be sure to thoroughly purge the refrigerant circuit to keep oxidized scale from forming.
3	Replace the parts by heating the welded areas.	Be careful that the heat from welding can expand the residual CO <sub>2</sub> inside the pipe and cause it to gush out.

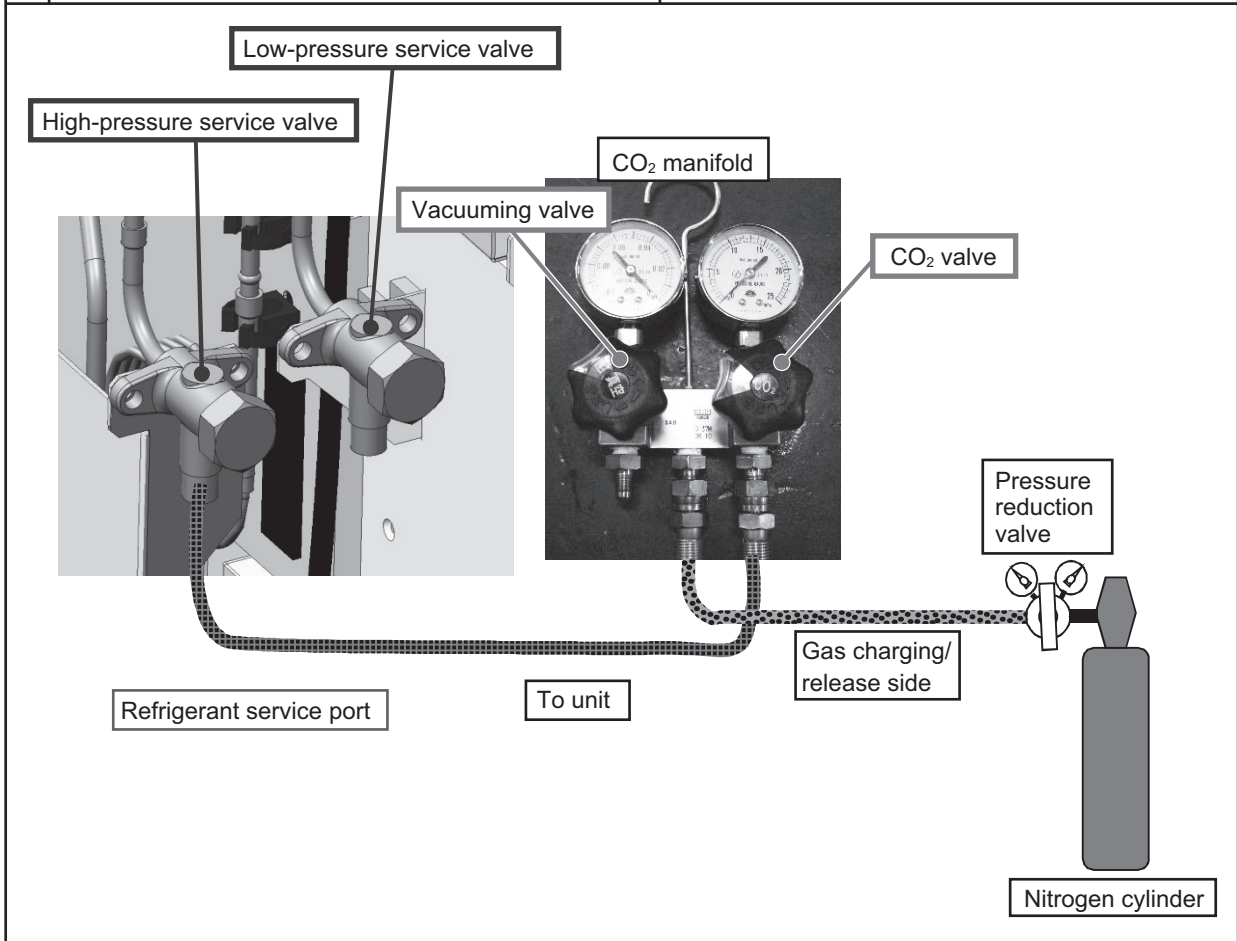

**(3) Gas leak test**

No.	Procedure	Cautionary notes
1	Connect the manifold to the high-pressure service valve. Fully close the low-pressure service valve.	CO <sub>2</sub> manifold has a structure different than that of HFC manifold. Refer to the "[5] CO <sub>2</sub> refrigerant manifold structure" in the Attachment.
2	Connect a pressure reduction valve to the nitrogen cylinder, and then connect the cylinder to the gas charging/release hose that connects to the manifold.	—
3	Charge the unit with nitrogen, adjusting the pressure with the reduction valve to 8.5 MPa. Once the charging pressure reaches 8.5MPa, shut off the nitrogen cylinder valve.	Use caution because the charging pressure is high. Charge nitrogen from the high-pressure side.
4	Test the brazed areas for gas leak, using foaming solution.	Make sure there is no leak.
5	When the leak test is done, slowly open the low-pressure service valve to release the nitrogen.	Be careful that nitrogen may suddenly gush out. Purge the nitrogen only from the low-pressure side or from both the low- and high-pressure sides simultaneously, but not only from the high-pressure side.

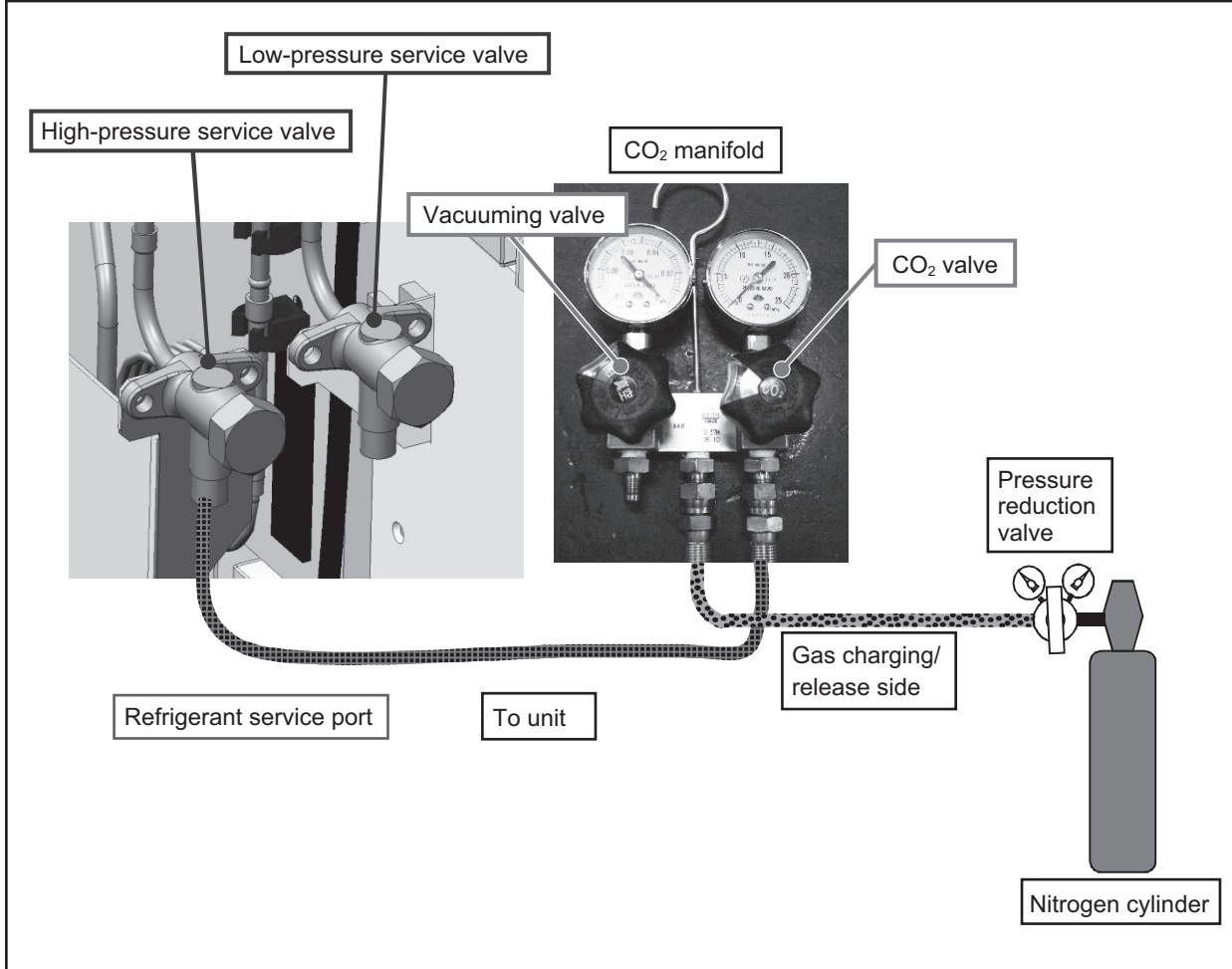

**(4) Vacuuming the refrigerant circuit**

No.	Procedure	Cautionary notes
1	Fully close the low-pressure service valve on the unit.	–
2	Connect the CO <sub>2</sub> cylinder to the gas charging/release hose that connects to the manifold.	This is done to evacuate the hose between the unit and the CO <sub>2</sub> cylinder.
3	Connect a packless valve to the vacuum port on the manifold via a hose, and connect a vacuum pump to the packless valve (see the figure below).	Packless valve is necessary for checking the degree of vacuum inside the unit. Ordinary hose can be connected to this valve.
4	Make sure the high-pressure service valve, the CO <sub>2</sub> valve on the manifold, and the packless valve are OPEN.	–
5	Make sure the vacuum valve on the manifold, the low-pressure service valve, and CO <sub>2</sub> cylinder valve are securely CLOSED.	Because residual refrigerant may be present in dry ice condition, perform vacuuming three times as shown below.
6	Operate the vacuum pump, and slowly open the vacuum valve on the manifold to start vacuuming. The target degree of vacuum is 266 Pa or below.	Vacuum for 30 minutes. →Leave the refrigerant circuit open to air for 5 minutes. →Vacuum for 30 minutes. →Leave the refrigerant circuit open to air for 5 minutes. →Vacuum for 60 minutes. →Check the degree of vacuum five minutes later. →Proceed to the next step if the degree of vacuum is satisfactory.

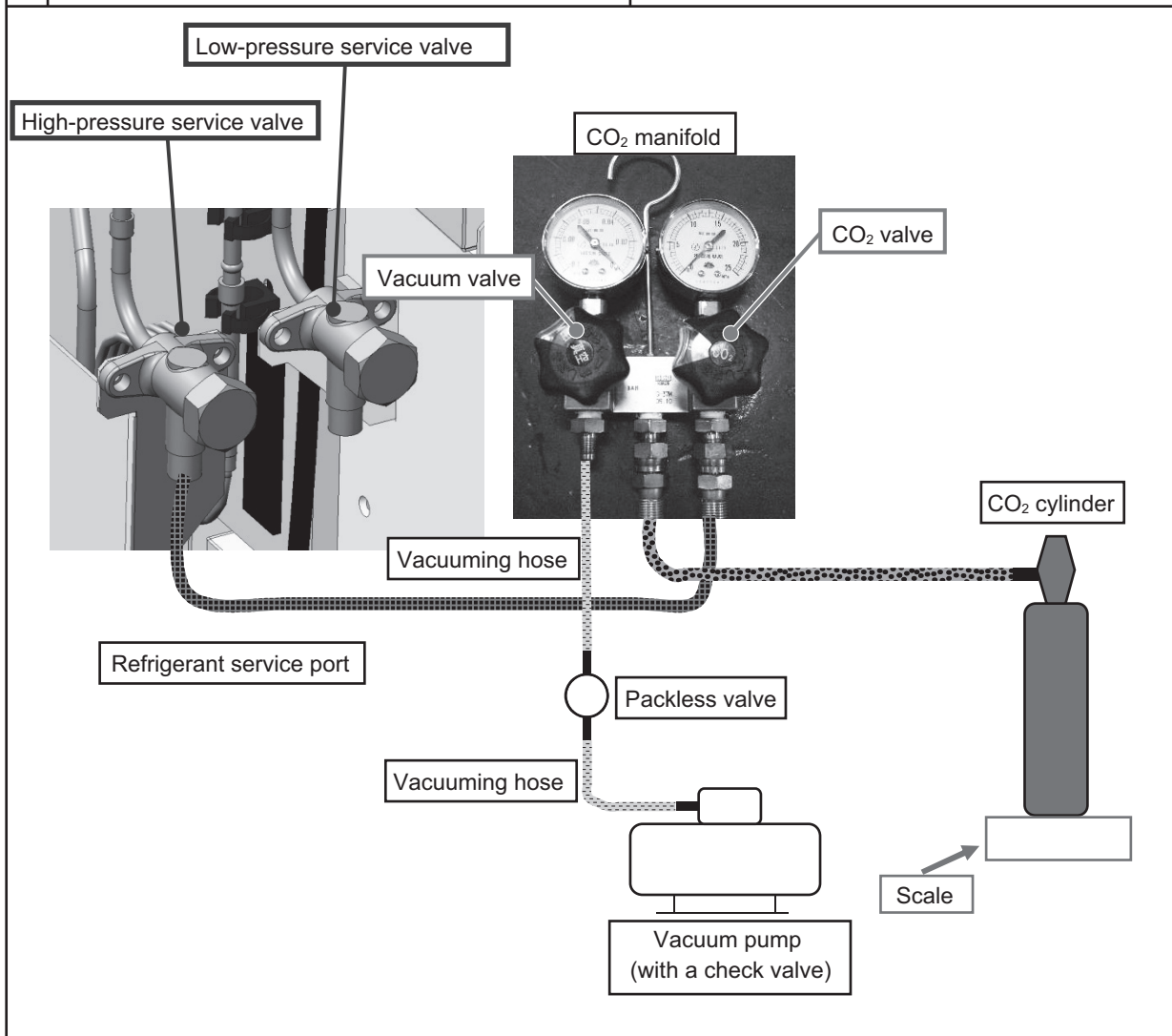

**(5) Refrigerant charging 1: Charging the unit with refrigerant while the unit is stopped**

No.	Procedure	Cautionary notes
1	First, check the degree of vacuum. When the vacuum completion time is reached, close the packless valve.	If measurement of vacuum degree with a vacuum gauge is possible, make sure the gauge reading is 266 Pa or below.
2	Make sure the vacuum is properly held (the vacuum gauge on the manifold does not rise).	-
3	Securely close the vacuum valve on the manifold.	Failing to close the valve will cause refrigerant to flow into the vacuumed circuit in the later step of refrigerant charging, which will pose serious safety hazards and will damage the vacuum gauge.
4	Place the CO <sub>2</sub> cylinder on a scale to allow for the measurement of the weight of the cylinder.	-
5	Securely close the high-pressure service valve on the unit, open the valve on the CO <sub>2</sub> cylinder, and fill the section of the hose between the unit and the CO <sub>2</sub> cylinder with CO <sub>2</sub> .	Check the refrigerant charge at this point.
6	Open the high-pressure service valve on the unit, and charge the unit with the specified amount of CO <sub>2</sub> .	Charge CO <sub>2</sub> from the high-pressure side.
7	When the amount of CO <sub>2</sub> charge reaches the specified amount (6.5kg), stop the charge by closing the high-pressure service valve on the unit.	-

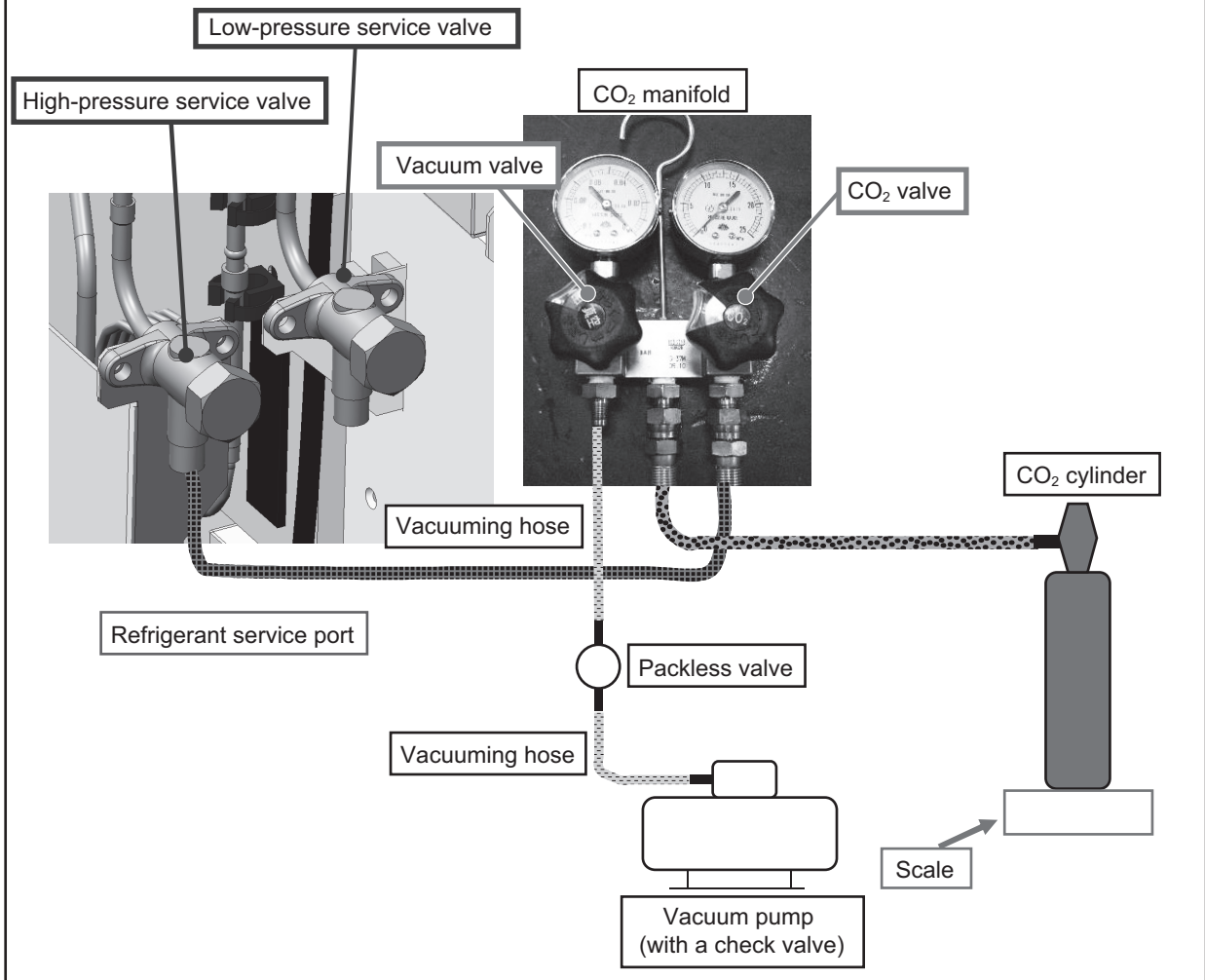



**[5] CO<sub>2</sub> refrigerant manifold structure**

**1. Structural comparison between CO<sub>2</sub> manifold and HFC/HCFC manifold**

**(1) CO<sub>2</sub> manifold**

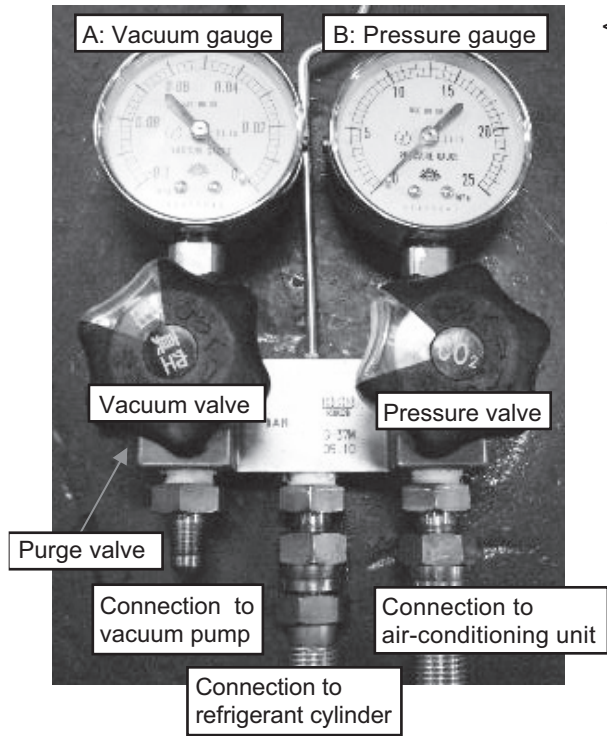

<Circuit structure>

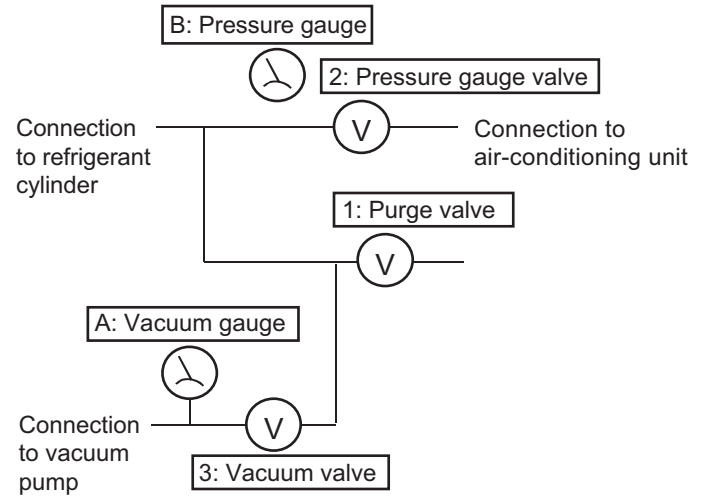

**(2) H(C)FC manifold**

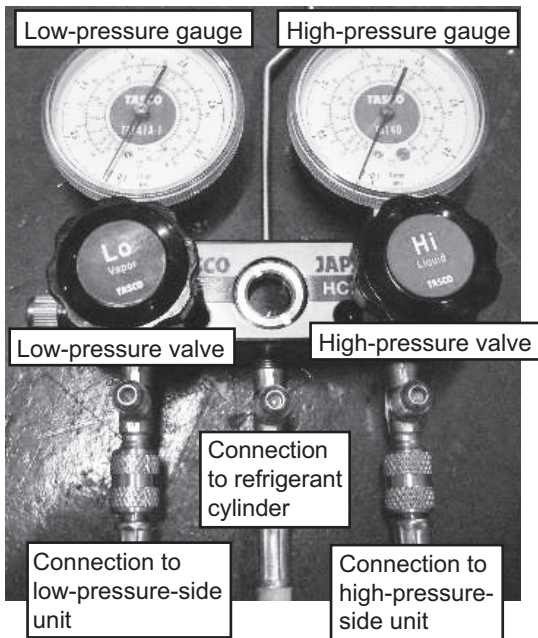

<Circuit structure>

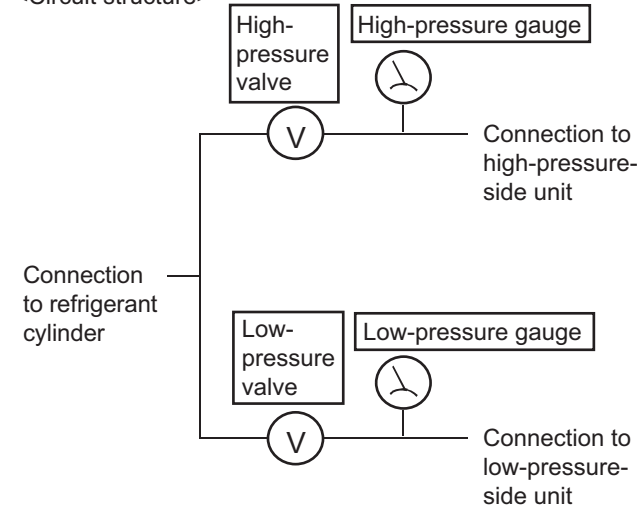

**2. Differences of CO<sub>2</sub> manifold from the HFC/HCFC manifold**

- 1) CO<sub>2</sub> manifold only has one connection to the unit.
- 2) CO<sub>2</sub> manifold has a designated vacuum circuit that ordinary manifolds do not have.
- 3) Pressure gauge on the CO<sub>2</sub> manifold is only open to the refrigerant cylinder when valve is closed. (H(C)FC manifold is also open to the unit connection circuit when valve is closed.)



## [6] Characteristics of the Conventional and the New Refrigerants

### 1. Chemical property

As with R22, the new refrigerant (R744) is low in toxicity and chemically stable nonflammable refrigerant. However, because the specific gravity of vapor refrigerant is greater than that of air, leaked refrigerant in a closed room will accumulate at the bottom of the room and may cause hypoxia.

If exposed to an open flame, refrigerant will generate poisonous gases. Do not perform installation or service work in a confined area.

	R744 (CO <sub>2</sub> )	HFC type		HCFC type
		R410A	R407C	R22
		R32/R125	R32/R125/R134a	R22
Composition (wt%)	(100)	(50/50)	(23/25/52)	(100)
Type of Refrigerant	Single Refrigerant	Pseudo-azeotropic Refrigerant	Non-azeotropic Refrigerant	Single Refrigerant
Chloride	Not included	Not included	Not included	Included
Safety Class	A1	A1/A1	A1/A1	A1
Molecular Weight	44.0	72.6	86.2	86.5
Boiling Point (°C/°F)	-78.4/-109.1	-51.4/-60.5	-43.6/-46.4	-40.8/-41.4
Steam Pressure (25°C,MPa/77°F,psi) (gauge)	6.30/914	1.557/226	0.9177/133	0.94/136
Saturated Steam Density (25°C,kg/m <sup>3</sup> /77°F,psi)	242	64.0	42.5	44.4
Flammability	Nonflammable	Nonflammable	Nonflammable	Nonflammable
<b>Ozone Depletion Coefficient (ODP)<sup>*1</sup></b>	<b>0</b>	<b>0</b>	<b>0</b>	<b>0.055</b>
Global Warming Coefficient (GWP) <sup>*2</sup>	1	2090	1774	1810
Refrigerant Charging Method	Refrigerant charging in the liquid state	Refrigerant charging in the liquid state	Refrigerant charging in the liquid state	Refrigerant charging in the gaseous state
Replenishment of Refrigerant after a Refrigerant Leak	Available	Available	Available	Available

\*1 When CFC11 is used as a reference

\*2 When CO<sub>2</sub> is used as a reference

### 2. Pressure characteristics

The pressure in the system using R744 is 7 to 14 times as great as that in the system using R22.

Temperature (°C/°F)	Saturation Pressure (gauge)			
	R744	R410A	R407C	R22
	MPa/psi	MPa/psi	MPa/psi	MPa/psi
-20/-4	1.87/271	0.30/44	0.18/26	0.14/20
0/32	3.39/492	0.70/102	0.47/68	0.40/58
20/68	5.63/817	1.34/194	0.94/136	0.81/117
40/104	-	2.31/335	1.44/209	1.44/209
60/140	-	3.73/541	2.43/354	2.33/338
65/149	-	4.17/605	2.74/399	2.60/377

## [7] Notes on Refrigerating Machine Oil

### 1. Refrigerating machine oil in the HFC refrigerant system

R744 refrigerants use a refrigerating machine oil different from that used in the R22 or HFC system.

Refrigerant	Refrigerating machine oil
R744	PAG (Polyalkylene glycol)
R22	Mineral oil
R407C	Ester oil
R410A	Ester oil

### 2. Effects of contaminants\*1

Refrigerating machine oil used in the R744 system must be handled with special care to keep contaminants out. The table below shows the effect of contaminants in the refrigerating machine oil on the refrigeration cycle.

### 3. The effects of contaminants in the refrigerating machine oil on the refrigeration cycle.

Cause		Symptoms	Effects on the refrigerant cycle
Water infiltration		Frozen expansion valve and capillary tubes	Clogged expansion valve and capillary tubes Poor cooling performance Compressor overheat Motor insulation failure Burnt motor Coppering of the orbiting scroll Lock Burn-in on the orbiting scroll
		Hydrolysis	
Air infiltration		Oxidization	
Infiltration of contaminants	Dust, dirt	Adhesion to expansion valve and capillary tubes	Clogged expansion valve, capillary tubes, and drier Poor cooling performance Compressor overheat
		Infiltration of contaminants into the compressor	Burn-in on the orbiting scroll
	Mineral oil etc.	Sludge formation and adhesion	Clogged expansion valve and capillary tubes Poor cooling performance Compressor overheat
Oil degradation		Burn-in on the orbiting scroll	

\*1. Contaminants is defined as moisture, air, processing oil, dust/dirt, wrong types of refrigerant, and refrigerating machine oil.



---

## II Restrictions

[1] System Configuration.....	17
[2] Types and Maximum allowable Length of Cables .....	18
[3] Main Power Supply Wiring and Switch Capacity .....	19
[4] Sample Installation.....	23
[5] Switch Types and the Factory Settings.....	24
[6] Configuring the Settings.....	25
[7] Water Pipe Installation .....	33
[8] Using the Unit in Sub-freezing or Snowy Conditions .....	37
[9] Secondary side control system .....	38



## [1] System Configuration

### Schematic Diagrams of Individual and Multiple Systems

#### (1) Individual system

\* Each unit is operated individually by connecting a dry contact switch/relay to each unit.

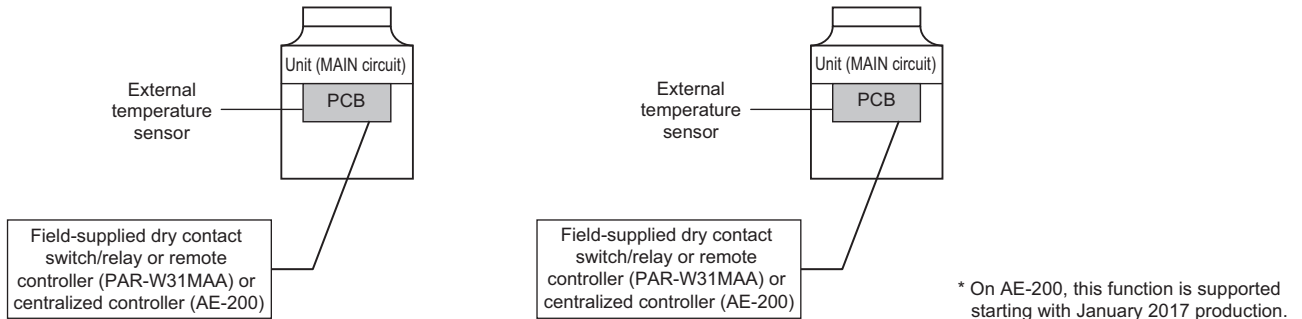

Refer to the sections “[5] Switch Types and the Factory Settings” (page 24) and “(3) System configuration procedures: Individual system” (page 27) for further details.

#### (2) Multiple system (2-16 units)

\* A group of unit that consists of one main unit and up to 15 sub units is operated collectively by connecting an external water temperature sensor and a dry contact switch/relay to the main unit.

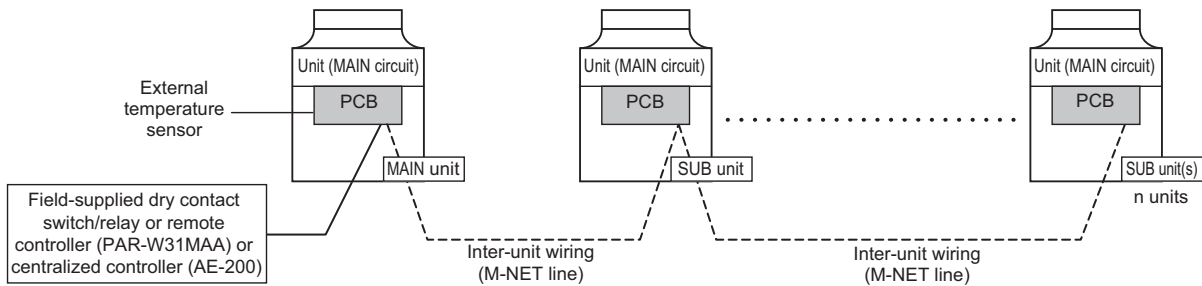

Refer to the sections “[5] Switch Types and the Factory Settings” (page 24) and “(4) System configuration procedures : Multiple system” (page 29) for further details.

## [2] Types and Maximum allowable Length of Cables

### Wiring work

#### (1) Notes

- 1) Have all electrical work performed by an authorized electrician according to the local regulations and instructions in this manual.
- 2) Install external transmission cables at least 5cm [1-31/32"] away from the power supply cable to avoid noise interference. (Do not put the control cable and power supply cable in the same conduit tube.)
- 3) Provide grounding for the outdoor unit as required.
- 4) Run the cable from the electric box of the outdoor unit in such way that the box is accessible for servicing.
- 5) Do not connect power supply wiring to the terminal block for transmission line. Doing so will damage the electronic components on the terminal block.
- 6) Use 2-core shielded cables as transmission cables.

Use a separate 2-core control cable for each refrigerant system. Do not use a single multiple-core cable to connect units that belong to different refrigerant systems. The use of a multiple-core cable may result in signal transmission errors and malfunctions.

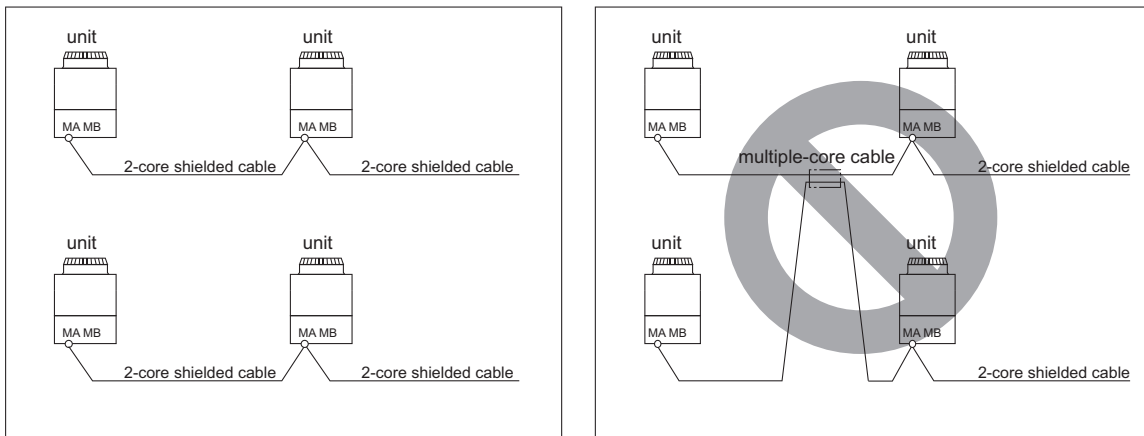

TB3: Terminal block for transmission line

#### (2) Control wiring

Different types of control wiring are used for different systems.

##### Types and maximum allowable length of cables

Control lines are categorized into 2 types: transmission line and remote controller line.

Use the appropriate type of cables and observe the maximum allowable length specified for a given system. If a given system has a long transmission line or if a noise source is located near the unit, place the unit away from the noise source to reduce noise interference.



### [3] Main Power Supply Wiring and Switch Capacity

#### Schematic Drawing of Wiring (Example)

- Ⓐ: Switch (with current breaking capability)
- Ⓑ: Current leakage breaker
- Ⓒ: Outdoor unit

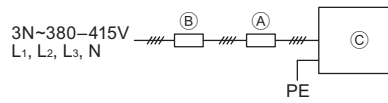

#### Main power supply wire size, switch capacities, and system impedance

Model	Minimum wire thickness (mm <sup>2</sup> )			Current leakage breaker	Local switch (A)		No-fuse breaker (A)	Max. Permissible System Impedance
	Main cable	Branch	Ground		Capacity	Fuse		
QAHV-N560YA-HPB	10	-	10	63 A 100 mA 0.1 sec. or less	63	63	63	0.21 Ω

1. Use a dedicated power supply for each unit. Ensure that each unit is wired individually.
2. When installing wiring, consider ambient conditions (e.g., temperature, sunlight, rain).
3. The wire size is the minimum value for metal conduit wiring. If voltage drop is a problem, use a wire that is one size thicker.  
Make sure the power-supply voltage does not drop more than 10%.
4. Specific wiring requirements should adhere to the wiring regulations of the region.
5. Power supply cords of appliances for outdoor use shall not be lighter than polychloroprene sheathed flexible cord (design 60245 IEC57).
6. A switch with at least 3 mm contact separation in each pole shall be provided by the Air Conditioner installer.
7. Do not install a phase advancing capacitor on the motor. Doing so may damage the capacitor and result in fire.

#### ⚠ Warning:

- Be sure to use specified wires and ensure no external force is imparted to terminal connections. Loose connections may cause overheating and fire.
- Be sure to use the appropriate type of overcurrent protection switch. Note that overcurrent may include direct current.

#### ⚠ Caution:

- Some installation sites may require an installation of an earth leakage breaker for the inverter. If no earth leakage breaker is installed, there is a danger of electric shock.
- Only use properly rated breakers and fuses. Using a fuse or wire of the wrong capacity may cause malfunction or fire.

#### Note:

- This device is intended for the connection to a power supply system with a maximum permissible system impedance shown in the above table at the interface point (power service box) of the user's supply.
- Ensure that this device is connected only to a power supply system that fulfills the requirements above. If necessary, consult the public power supply company for the system impedance at the interface point.
- This equipment complies with IEC 61000-3-12 provided that the short-circuit power  $S_{SC}$  is greater than or equal to  $S_{SC} (*2)$  at the interface point between the user's supply and the public system. It is the responsibility of the installer or user of the equipment to ensure, in consultation with the distribution network operator if necessary, that the equipment is connected only to a supply with a short-circuit power  $S_{SC}$  greater than or equal to  $S_{SC} (*2)$ .

$S_{SC} (*2)$

$S_{SC}$ (MVA)
2.62 Ω

### Control cable specifications

Remote controller cable	Size	0.3 - 1.25 mm <sup>2</sup> (Max. 200 m total)*2
	Recommended cable types	CVV
M-NET cable between units	Size	Min. 1.25 mm <sup>2</sup> (Max. 120 m total)
	*1 Recommended cable types	Shielded cable CVVS, CPEVS or MVVS
External input wire size		Min. 0.3 mm <sup>2</sup>
External output wire size		1.25 mm <sup>2</sup>

\*1 Use a CVVS or CPEVS cable (Max. total length of 200 m) if there is a source of electrical interference near by (e.g., factory) or the total length of control wiring exceeds 120 m.

\*2 When the wiring length exceeds 10 m, use wire of 1.25 mm<sup>2</sup>.

### <1> Schematic Diagram of a Unit and Terminal Block Arrangement

To remove the front panel of the control box, unscrew the four screws and pull the panel forward and then down.

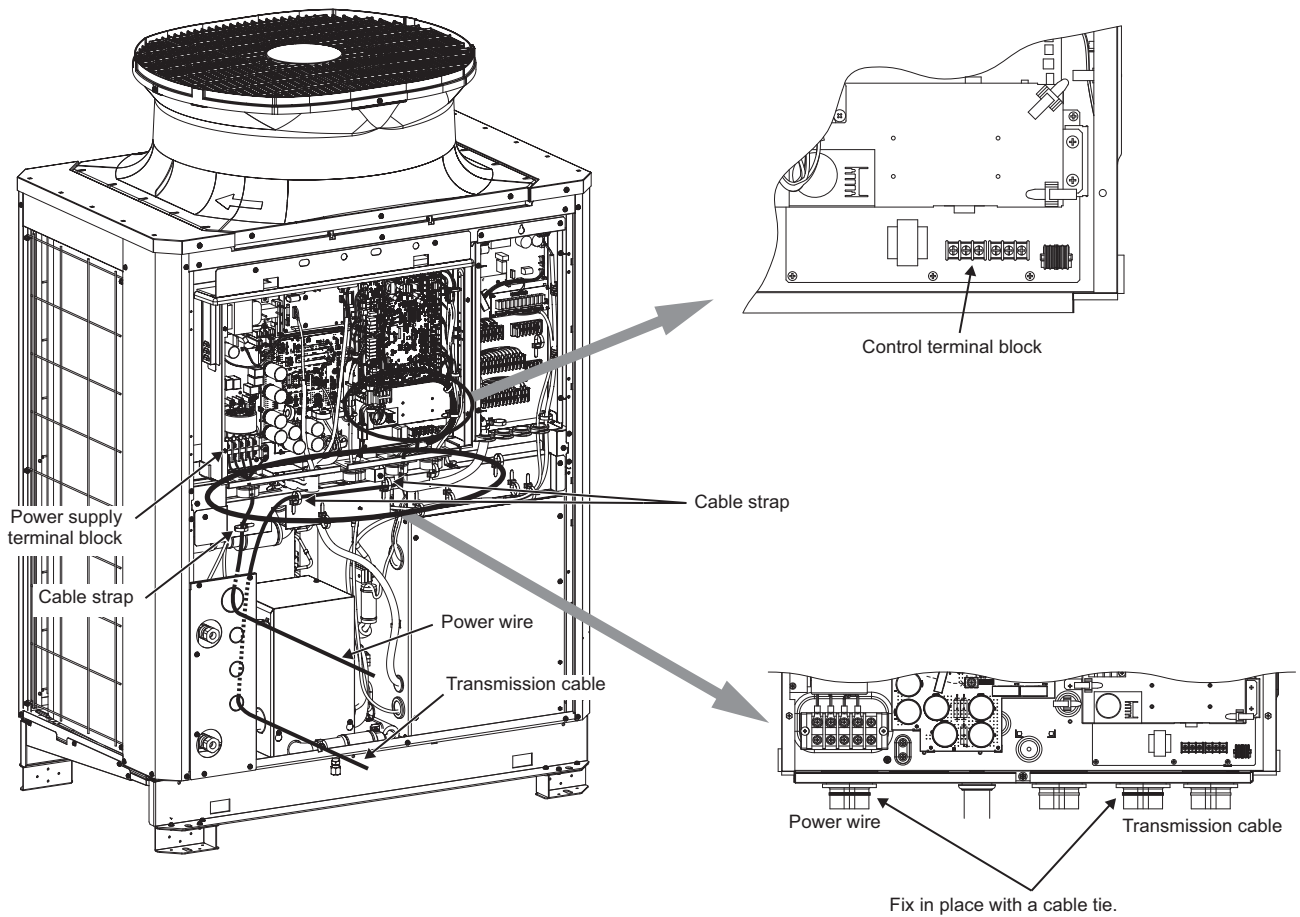

**Important:** Power supply cables larger than 25 mm<sup>2</sup> in diameter are not connectable to the power supply terminal block (TB2). Use a pull box to connect them.

### <2> Installing the conduit tube

- Punch out the knockout hole for wire routing at the bottom of the front panel with a hammer.
- When putting wires through knockout holes without protecting them with a conduit tube, deburr the holes and protect the wires with protective tape.
- If damage from animals is a concern, use a conduit tube to narrow the opening.

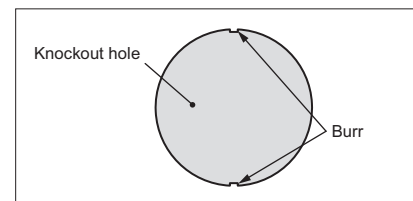

Note:

- Make sure the cables are not coming out of the rubber bushing cut.

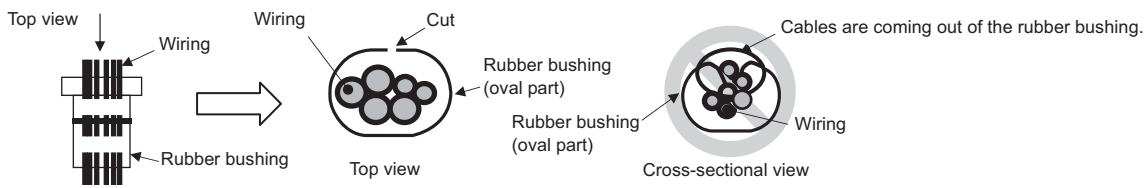

- When threading the wiring through the rubber bushing, make sure the rubber bushing will not come off the sheet metal on the control box guard.



- When tying the supplied tie band around the rubber bushing, make sure to leave no gap between the ends.

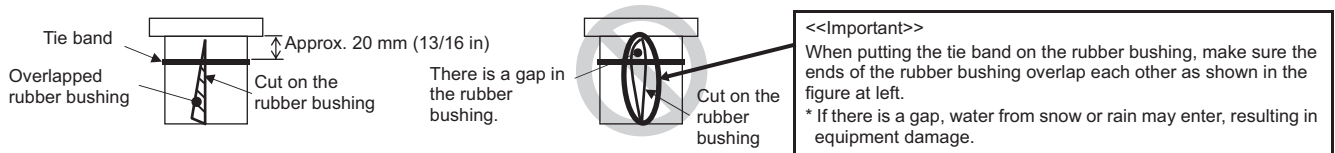

A power wire exceeding the specified power wire thickness cannot be connected to the power terminal block (TB2). Use a separate pull box.

To ensure that the transmission cable is not affected by electrical noise from the power cable, route the power cable away from the transmission cable (distance of at least 50 mm (2 in)).

### <3> Wiring for Configuring Secondary Side Control System

To configure a secondary side control system, you need to connect the wiring of the following three devices from the secondary side water circuit to the primary side unit.

- ① Flow sensor
- ② Secondary side thermistor
- ③ Pump + flow rate adjustment device (three-way valve, two-way valve, or inverter)

#### Wiring of secondary side circuit

Perform the installation work of steps (1) to (4) below.

(1) Open the panel.

Use a screwdriver to remove the service panel, terminal block box cover, and control box cover (only for system using flow rate adjustment valve (two-way valve or three-way valve)).

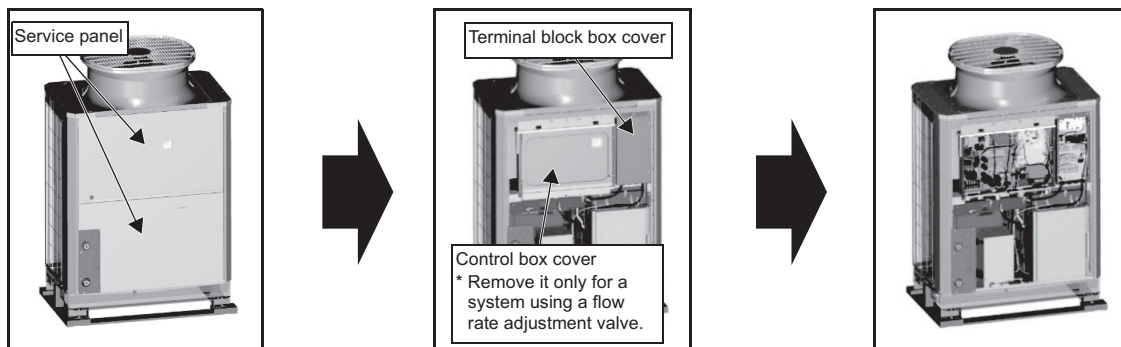

(2) Thread the wiring through into the unit

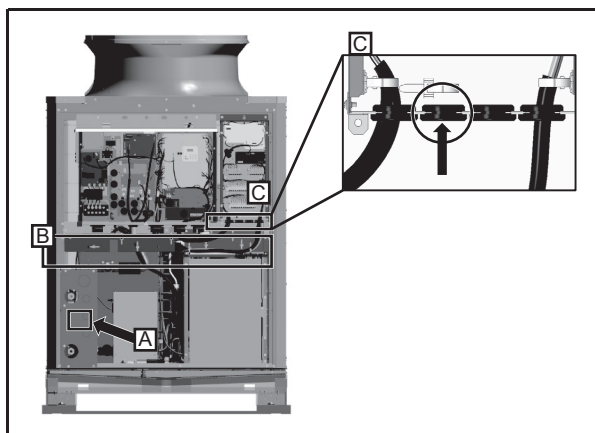

- ① Thread the flow sensor wiring through A in the figure.
- ② Hold the wiring with the cable strap inside the unit indicated as B in the figure to keep it out of contact with the pipes and other components.
- ③ Thread the wiring through the rubber bush indicated as C in the figure (second one from the left).

\* For details on the opening procedure of A and the wiring of B, refer to pages 20 and 21.

(3) Wiring connections

① Connect the flow sensor and flow rate adjustment device

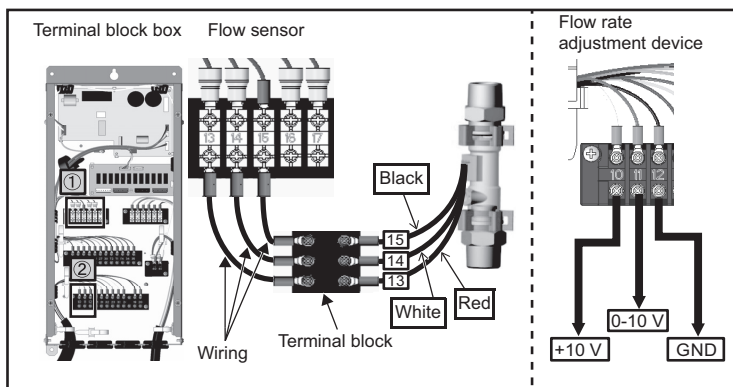

Connect the flow sensor wiring to the terminal block inside the BOX. The numbers on the wirings correspond to the numbers on the terminal block.

Connect each wiring to the correct terminal. When done, hold the excess wiring with the supplied cable tie (long). Also, hold the wirings in place with a cable tie (long) where indicated as B in the figure to keep them out of contact with the pipes and other components.

\* The 10-V power supply to be connected to No. 10 on the terminal block is not supplied.

Furthermore, make sure that the output of the 10-V power supply is within 10 V ±0.5 V.

\* For details on the wiring procedure of the separately sold thermistor, refer to the separately sold kit Q-1SCK.

\* For a system that outputs the pump on/off signal from the unit (system that uses a flow rate adjustment valve), connect the wires to 1-3 of CN512.

(4) Close the panel.

Using a screwdriver, re-place the SERVICE PANEL and the CONTROL BOX (SUB) cover.

**[4] Sample Installation**

**(1) Individual system**

\* Each unit is operated individually by connecting a dry contact switch/relay to each unit.

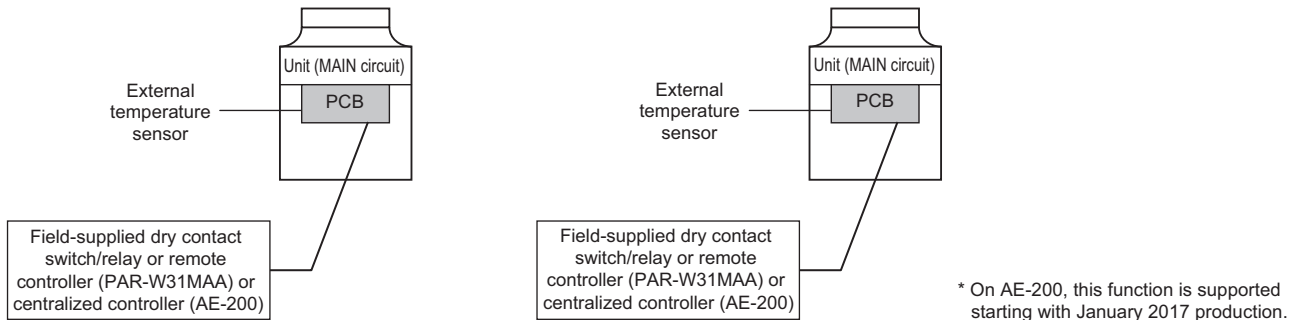

Refer to the sections “[5] Switch Types and the Factory Settings” (page 24) and “(3) System configuration procedures: Individual system” (page 27) for further details.

**(2) Multiple system (2-16 units)**

\* A group of unit that consists of one main unit and up to 15 sub units is operated collectively by connecting an external water temperature sensor and a dry contact switch/relay to the main unit.

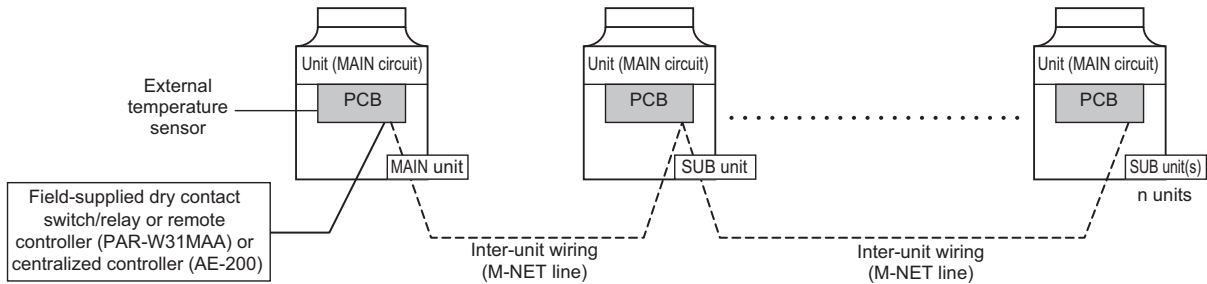

Refer to the sections “[5] Switch Types and the Factory Settings” (page 24) and “(4) System configuration procedures : Multiple system” (page 29) for further details.

## [5] Switch Types and the Factory Settings

### (1) Switch names and functions

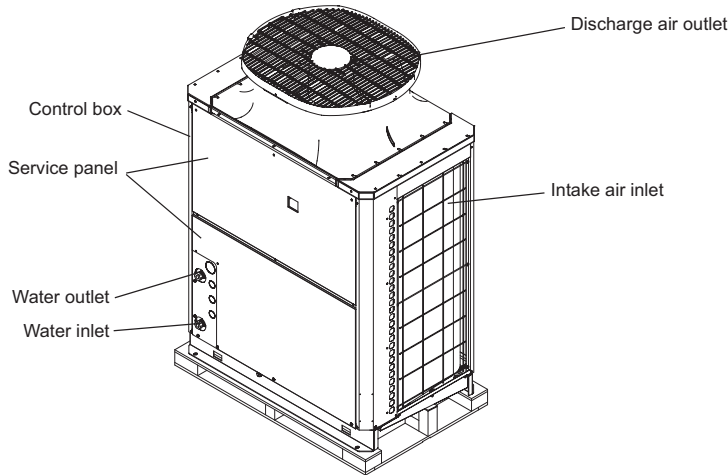

There are four main ways to set the settings as follows:

- ① Dip switches (SW1 - SW3)
- ② Dip switches used in combination with the push switches
- ③ Rotary switches
- ④ Slide switches

See below for how these switches are used to set certain items.

### Different types of switches on the PCB

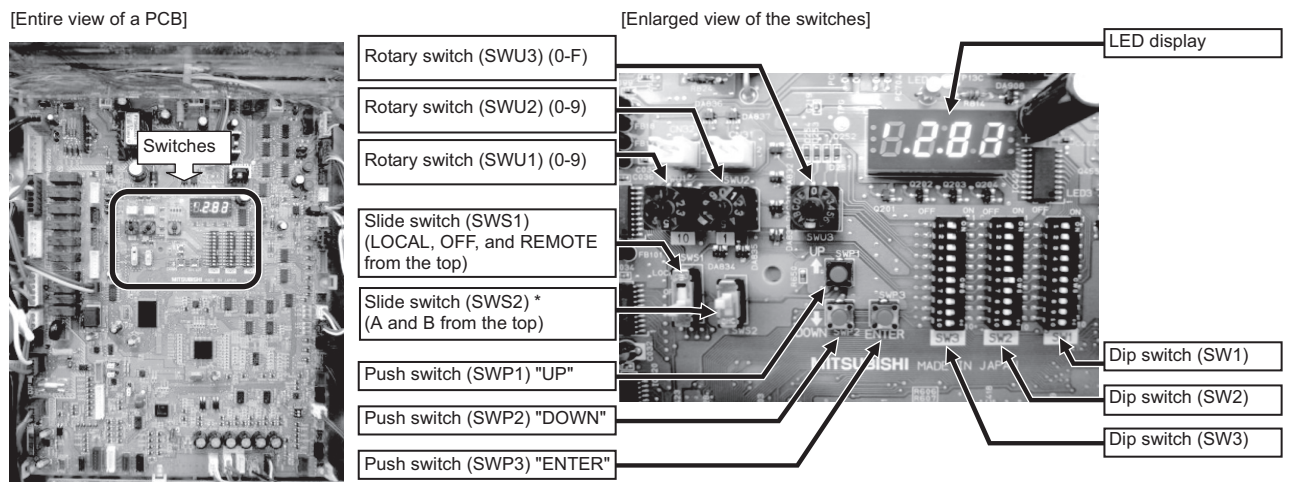

Set the slide switch SWS2 on the board inside the control box to the **lower side** during the trial run.

By default, it is set to the upper side for forced stop of the pump and compressor to prevent the pump being damaged by the anti-freezing process in no water passing status or valve closed status before the test run.

Upper side: A (under preparation)  
 Lower side: B (auto)  
 Always set to the lower side.

\* **Setting to the upper side forcefully stops the pump and compressor thus the unit does not operate.**

\* **When SWS2 is set to the upper side, the display shows "P.OFF" and the setting cannot be made. When "P.OFF" appears, set SWS2 to the lower side.**

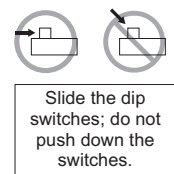

**[6] Configuring the Settings**

The settings must be set only by a qualified personnel.

**Making the settings**

Use the LED display and the three push switches (SWP1 (↑), SWP2 (↓), and SWP3 (Enter)) to change the current settings on the circuit board and to monitor various monitored values.

**(1) Setting procedures**

Take the following steps to set the push switches SWP1 through SWP3. These switches must be set after the dip switches SW2 and SW3 have been set.

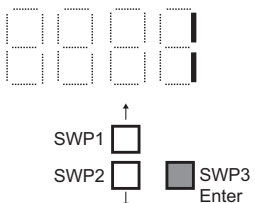
①  Normally an item code appears on the display. (The figure at left shows the case where item code 1 is displayed.) Press SWP3 (Enter) to advance the item code.

↓

Press SWP3 (Enter) until the item code appears that corresponds to the item to change or monitor its value.

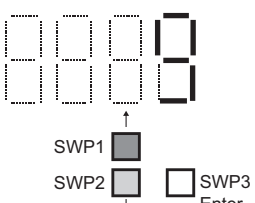
②  The left figure shows a display example (Code 9 Outlet hot water temperature setting).

↓

Press either SWP1 (↑) or SWP2 (↓) to display the value that corresponds to the selected item.

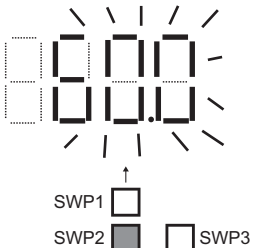
③  The current setting value will blink.

↓

The left figure shows that the current setting value is "60.0." To decrease this value to 58.0, for example, press SWP2 (↓). Press SWP1 (↑) to increase the value.

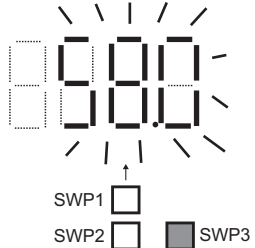
④  **<To change the settings>**

When the desired value is displayed (58.0 in the example at left), press SWP3 (Enter).

↓

The displayed value will stop blinking and stay lit. A lit LED indicates that the new setting has been saved.

\*Pressing SWP1 (↑) or SWP2 (↓) will change the blinking setting value, but the change will not be saved until SWP3 (Enter) is pressed. If SWP3 is not pressed within one minute, the change will not be saved and the display will return to the item code display mode. Press and hold SWP1 (↑) or SWP2 (↓) for one second or longer to fast forward through the numbers.

**<To view the monitored data>**

Press SWP3 (Enter) while the LED display is blinking (see step 3 above) to stop the blinking.

\*The values of the items that can only be monitored will not change when SWP1 (↑) or SWP2 (↓) is pressed.

The display will stop blinking and stay lit after a minute, and the display will automatically return to the item code display regardless of the type of values displayed.

To change the values of other items, repeat the steps from step 2 above.



**(2) Table of settings items**

Set the dip switches SW2 and SW3 as shown in the table below to set the value for the items in the "Setting item" column.

	Dip switch settings	Setting item	Item code	Unit	Lower limit	Upper limit	Initial value	Setting value	
Basic settings	SW2-10: OFF SW3-5, 6, 7: OFF SW3-8, 9, 10: ON	Unit address	105	-	1	8	2		
		Number of connected GS to M-NET	106	-	0	16	1		
		AE-200 connection (0: Not connected, 2: Connected)	107	-	0	2	0		
		Function 1 (Sub sensor: 2, Main sensor: 1, Sub unit: 0)	110	-	0	2	0		
		M-NET address of main sensor of own tank	111	-	1	50	1		
		Address of sensor connection unit	112	-	1	51	51		
		Secondary control availability (0: Not available 1: Available)	121	-	0	1	0		
Basic settings	SW2-10: OFF SW3-5-8, 10: OFF SW3-9: ON	Model display	0	-	-	-	-		
		Current time	1	Hour and minutes	0:00	23:59	-		
		Current inlet water temperature (display function only)	c01	°C	-	-	-		
		Current outlet water temperature (display function only)	c02	°C	-	-	-		
		Outdoor temperature (display function only)	c03	°C	-	-	-		
		Storage tank water temperature (display function only)	c04	°C	-	-	-		
		Demand control - maximum capacity setting	2	%	0	100	100		
		Demand control - start time	3	Hour and minutes	0:00	23:59	13:00		
		Demand control - end time	4	Hour and minutes	0:00	23:59	16:00		
		Outlet hot water temperature (boiling temperature)	9	°C	40	Secondary control disabled: 90.0 Secondary control enabled: 80.0	65		
		High- and low-pressure display interval P	1051	Seconds	0	100	3		
		Low noise operation - maximum capacity	1054	%	0	100	70		
		Low noise operation - start time	1058	Hour and minutes	0:00	23:59	0:00		
		Low noise operation - end time	1059	Hour and minutes	0:00	23:59	0:00		
	Basic settings	SW2-10: OFF SW3-5-7, 9, 10: OFF SW3-8: ON	Thermo-ON prohibition time Sjs1	1025	Seconds	0	480	60	
			Sensor method setting (0: Local control, 1: Three-sensor, 2: Six-sensor)	1214	-	0	2	0	
			Mode 1 Thermo-ON thermistor selection	1500	-	1	Six-sensor system: 6 Other system: 3	3	
			Mode 1 Thermo-OFF thermistor selection	1501	-	1	Six-sensor system: 6 Other system: 3	3	
			Mode 2 Thermo-ON thermistor selection	1502	-	1	Six-sensor system: 6 Other system: 3	1	
			Mode 2 Thermo-OFF thermistor selection	1503	-	1	Six-sensor system: 6 Other system: 3	2	
			Mode 3 Thermo-ON thermistor selection	1504	-	1	Six-sensor system: 6 Other system: 3	1	
			Mode 3 Thermo-OFF thermistor selection	1505	-	1	Six-sensor system: 6 Other system: 3	3	
			Number of water control modes	1507	-	1	3	1	
Mode 1 Thermo differential value			1508	-	0	30	10		
Mode 2 Thermo differential value	1509	-	0	30	10				
Mode 3 Thermo differential value	1510	-	0	30	10				
Anti-freezing setting (0: Outdoor, 1: Indoor)	1514	-	0	1	0				

**(3) System configuration procedures: Individual system**

**1. Set the dip switches on the MAIN circuit board.**

Set the dip switches (labeled A in the figure at right) that correspond to the local system.

Refer to “Factory Switch Settings (Dip switch settings table)” (page 85) for further details.

- When AE200 is connected, set the dip switch 2-9 to ON.

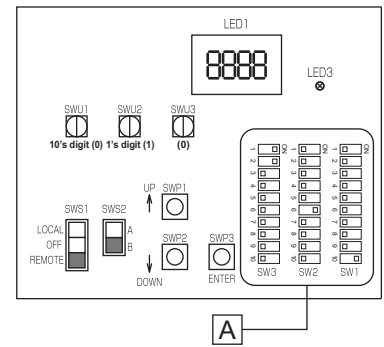

**2. Switch on the power to the unit.**

Check for loose or incorrect wiring, and then switch on the power to the unit.

When the power is switched on, the following codes will appear on the LED:

- [EEEE] will appear on LED1 in the circuit board (labeled A in the figure at right).
- [--ng] is displayed before the water flow rate adjustment operation is performed. Cancel the [--ng] display by using one of the following methods.
  - Press SWP3.
  - Press SWP1 or SWP2.

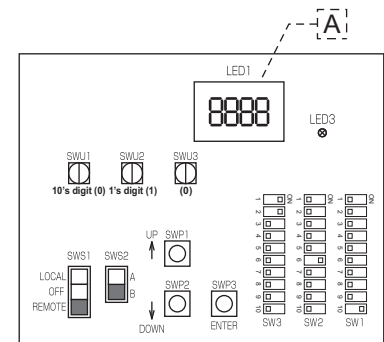

**3. Set the preset values with the switches on the circuit board.**

- (1) Set the dip switches SW2 and SW3 by following the procedure in page 101. (Set the dip switches 3-8, 3-9, and 3-10 to ON.)
  - \* [EEEE] will disappear, and an item code ([101]) will appear on LED1 (labeled B in the figure at right).
- (2) Use SWP3 to toggle through the item codes and select an item code to change its current value. (The item codes will appear in the following order: [101]→[104]→[105]→[106]→ [107]....
- (3) Use SWP1 to increase the value and SWP2 to decrease the value.
- (4) Press SWP3 to save the changed value.
- (5) Set the dip switches 3-8, 3-9, and 3-10 to OFF.
- (6) When connecting AE-200, perform the procedures described in 4 on page 31.

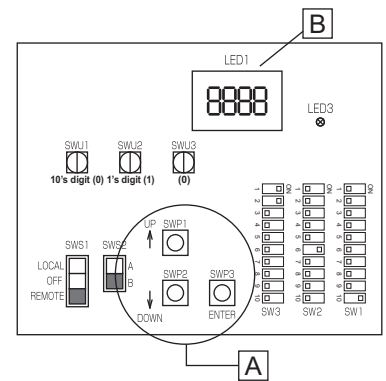

Following the steps above, set the value for the following items as necessary.

- [101] Not used
- [104] Not used
- [105] Function setting\* (When AE-200 is not connected to QAHV, the values set by rotary switches SWU1 and SWU2 are set as the preset values. When AE-200 is connected to QAHV, set the preset values referring to the notes below.)
- [106] Total number of units in the system (Initial value: 1) (Leave it as it is.)
- [107] "2" when connected to AE-200 (Initial value: 0)
- [108] Not used
- [109] Not used
- [110] Function setting ("1" when connected to AE-200) (Initial value: 0)
- [111] M-NET address of main sensor of own tank (Initial value: 1)
- [112 to 120] Not used
- [121] Secondary side control is enabled when "1" is set. (Initial value: 0)

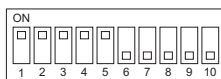

The figure at left shows that the switches 1 through 5 are set to ON and 6 through 10 are set to OFF.

\* When connecting AE-200 and remote controller (PAR-W31MAA) simultaneously, make the settings above, and then turn off the power, turn it back on, and set "1" for item code [105]. After these settings, perform the procedures described in (5) on page 32.

\* Set SWS1 to OFF from the remote controller or with the local switch. Settings cannot be changed unless the ON/OFF switch is set to OFF.

**(4) System configuration procedures : Multiple system**

- 1. Set the dip switches and rotary switches.**  
(Switches on the main unit\* AND on all sub units)

**System configuration diagram**

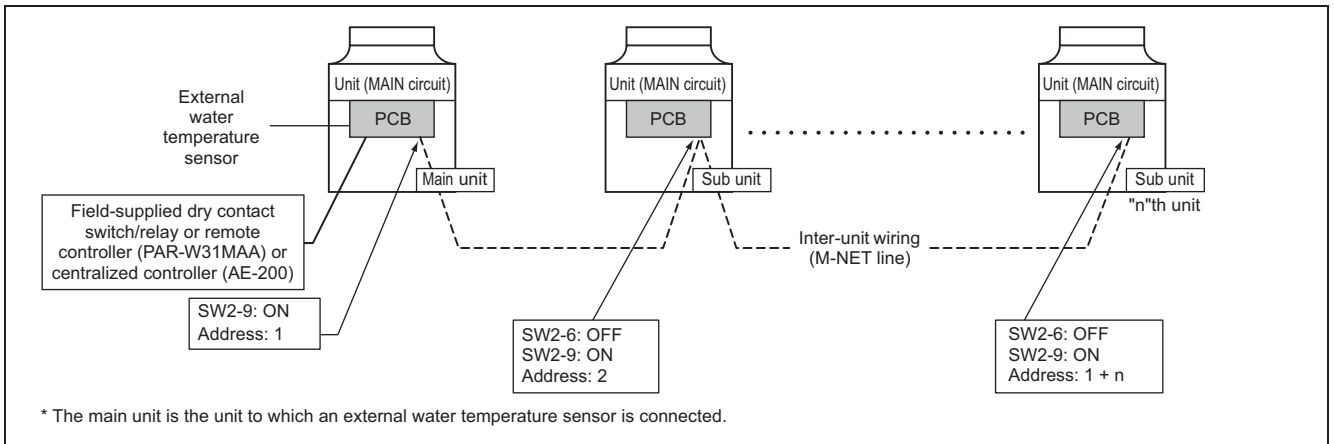

**Setting the switches on the main unit**

Set the dip switch SW2-9 to ON. (multiple unit control) (labeled A in the figure at right)

Refer to "Factory Switch Settings (Dip switch settings table)" (page 85) for further details.

Make sure the address of the main unit is set to "1" (labeled B in the figure at right).

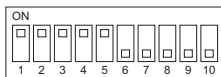
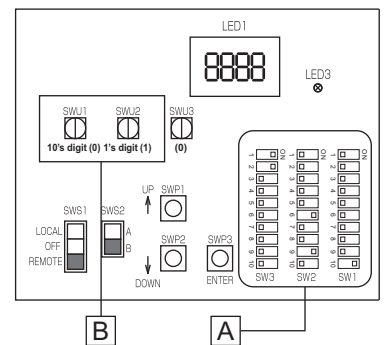

The figure at left shows that the switches 1 through 5 are set to ON and 6 through 10 are set to OFF.

**Setting the switches on all sub units**

- (1) Set the dip switch SW2-9 to ON. (multiple unit control) (labeled A in the figure at right)
- (2) Set the addresses with the rotary switches. (labeled B in the figure at right). Set the 10's digit with SWU1, and set the 1's digit with SWU2. Assign sequential addresses on all sub units starting with 2.
- (3) Set the dip switch SW2-6 to OFF. (power supply to communication circuit)

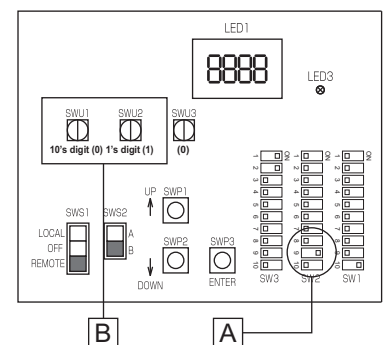

### 2. Switch on the power to the unit.

Check for loose or incorrect wiring, and then switch on the power to all units.

When the power is switched on, the following codes will appear on the LED:

- [EEEE] will appear on LED1 in the circuit board.

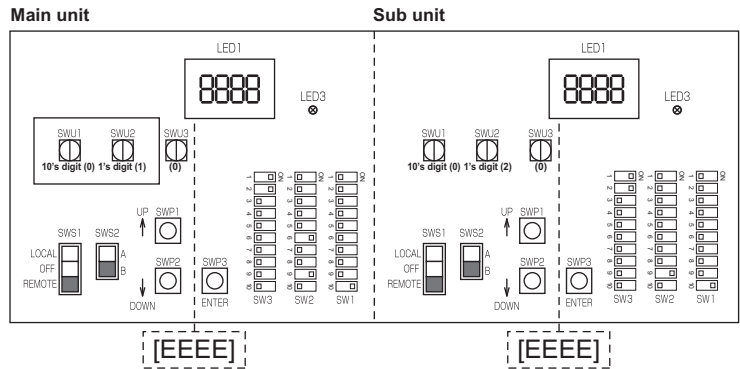

### 3. Set the preset values with the switches on the circuit board.

- (1) Set the dip switches SW2 and SW3 by following the procedure in page 101. (Set the dip switches 3-8, 3-9, and 3-10 to ON.)
- (2) Press either one of the push switches SWP1, 2, or 3 (labeled A in the figure at right) on the circuit board.
  - \* [EEEE] will disappear, and an item code ([101]) will appear on LED1 (labeled B in the figure at right).
- (3) Use SWP3 to toggle through the item codes, and select an item code to change its current value. (The item codes will appear in the following order: [101] → [104] → [105] → [106] → [107]....)
- (4) Use SWP1 to increase the value and SWP2 to decrease the value.
- (5) Press SWP3 to save the changed value.
- (6) Set the dip switches 3-8, 3-9, and 3-10, to OFF.

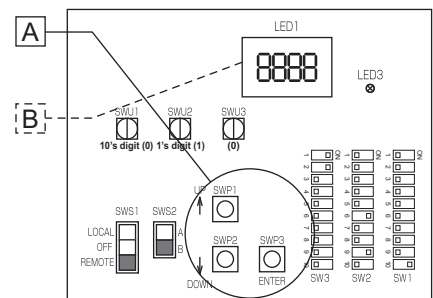

Following the steps above, set the value for the following items with the switches on the circuit as necessary. Item [106] must be set when multiple units are connected to a system.

- [101] Not used
- [104] Not used
- [105] Function setting (When AE-200 is not connected to QAHV, the values set by rotary switches SWU1 and SWU2 are set as the preset values. When AE-200 is connected to QAHV, set the preset values referring to the notes on page 31.)
- [106] Total number of units in the system (Initial value: 1)
- [107] "2" when connected to AE-200 (Initial value: 0)
- [108] Not used
- [109] Not used
- [110] Function setting (Initial value: 0)
- [111] M-NET address of main sensor of own tank (Initial value: 1)
- [112] Address of sensor connection unit
- [113 to 120] Not used
- [121] Secondary side control is enabled when "1" is set. (Initial value: 0)

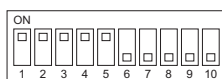

The figure at left shows that the switches 1 through 5 are set to ON and 6 through 10 are set to OFF.

\*For details of the settings, see page 97.

#### 4. Perform an initial setup on the unit

- (1) Set the sub unit rotary switch SWU3 on the unit (labeled A in the figure at right) to "F."  
 [EEEE] will appear in LED1 (labeled B in the figure at right). \*1
- (2) Press and hold the sub unit push switch (SWP3) (labeled C in the figure at right) for one second or longer.
  - While the system is starting up [9999] will appear on LED1 (labeled B in the figure at right).
- (3) Set the main unit rotary switch SWU3 on the unit (labeled A in the figure at right) to "F."  
 [EEEE] will appear in LED1 (labeled B in the figure at right). \*1
- (4) Press and hold the main unit push switch (SWP3) (labeled C in the figure at right) for one second or longer.
  - While the system is starting up [9999] will appear on LED1 (labeled B in the figure at right).
- (5) When start-up is complete, a control property [0001] will appear.
  - Then, five seconds later, [FFFF] will appear. \*2
- (6) Set the rotary switch SWU3 (labeled A in the figure at right) back to "0."  
 The start-up process is complete, and the settings for such items as clock, peak-demand control, schedule, and thermistor settings can now be made.

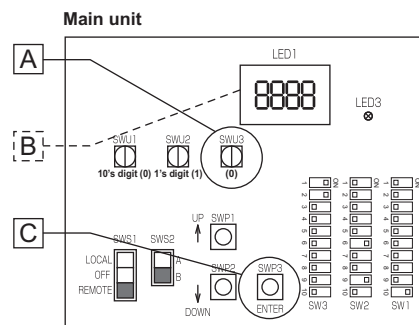

- \*1 If the start-up process has already been completed, [FFFF] (instead of [EEEE]) will appear when the rotary switch SWU3 is set to "F."
- \*2 [--ng] is displayed before the water flow rate adjustment operation is performed.  
 Refer to "2. Switch on the power to the unit." on page 27 for how to cancel [--ng].

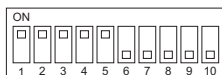

The figure at left shows that the switches 1 through 5 are set to ON and 6 through 10 are set to OFF.

\* When connecting AE-200 and remote controller (PAR-W31MAA) simultaneously, make the settings above, and then turn off the power, turn it back on, and set "1" for item code [105] for the unit to which a remote controller is connected. After these settings, perform the procedures described in (5) on page 32.

#### Slide switch (SWS1) settings

##### Individual system

SWS1 Setting	Unit Operation
LOCAL	Follows the input signal of the MAIN circuit
OFF	Ignores the signal input
REMOTE	Follows the input signal fed through a dry contact interface

Multiple system (SWS1 in the SUB circuit on both the main and sub units will be ineffective.)

SWS1 Setting		Unit Operation	
Main unit MAIN circuit	Sub unit MAIN circuit	Main unit	Sub unit
LOCAL	LOCAL	Follows the input signal of the Main unit	Follows the input signal of the Sub unit
	OFF		Ignores the signal input
	REMOTE		Follows the input signal of the Sub unit
OFF	LOCAL	Ignores the signal input	Ignores the signal input
	OFF		
	REMOTE		
REMOTE	LOCAL	Follows the input signal fed through a dry contact interface	Follows the input signal of the Main unit
	OFF		Ignores the signal input
	REMOTE		Follows the input signal of the Main unit

### **(5) Re-initializing the system**

When the settings for the items below have been changed, the system will require re-initialization.

- Dip switch SW2-9 (multiple unit control)
- External signal input setting: Item codes [105], [106], [107], [110], [111], [112], [121], and [1214]
- Rotary switches (SWU1 and SWU2) (unit address)

Take the following steps to re-initialize the system:

(1) Set the rotary switch SWU3 to "F."

[FFFF] will appear in the LED1.

(2) Press and hold the push switch SWP3 for one second or longer.

- While the system is starting up [9999] will appear on LED1.
- When start-up is complete, a control property [0001] will appear.
- Then, five seconds later, [FFFF] will appear.\*

\* If [EEEE] appears, perform the procedures in (2) again.

[-ng] is displayed before the water flow rate adjustment operation is performed.

(3) Set the rotary switch SWU3 back to "0."

### **(6) Resetting the system**

Take the following steps to reset the system. An error can also be reset by taking the steps below.

When an error on the MAIN unit is reset, all sub units will stop.

(1) Set the rotary switch SWU3 to "F."

[FFFF] will appear in the LED1.

(2) Press and hold the push switch SWP3 for one second or longer.

- While the system is starting up [9999] will appear on LED1.
- When start-up is complete, a control property [0001] will appear.
- Then, five seconds later, [FFFF] will appear.

(3) Set the rotary switch SWU3 back to "0."

## [7] Water Pipe Installation

### 1. Schematic Piping Diagram and Piping System Components

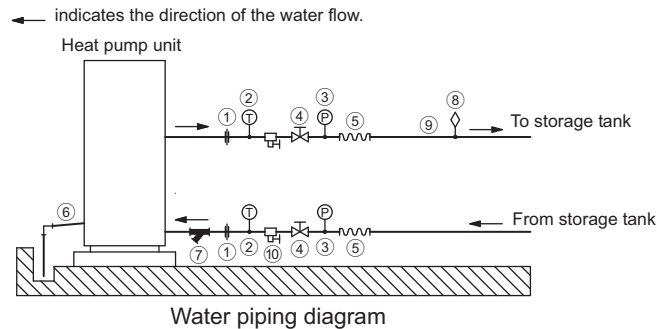

① Union joints/flange joints	Required to allow for a replacement of equipment.
② Thermometer	Required to check the performance and monitor the operation of the units.
③ Water pressure gauge	Recommended for checking the operation status.
④ Valve	Required to allow for a replacement or cleaning of the flow adjuster.
⑤ Flexible joint	Recommended to prevent the noise and vibration from the pump from being transmitted.
⑥ Drain pipe	Install the drain pipe with a downward inclination of between 1/100 and 1/200. To prevent drain water from freezing in winter, install the drain pipe as steep an angle as practically possible and minimize the straight line. For cold climate installation, take an appropriate measure (e.g., drain heater) to prevent the drain water from freezing.
⑦ Strainer	Install a strainer near the unit to keep foreign materials from entering the water-side head exchanger (supplied).
⑧ Air vent valve	Install air venting valves to the places where air can accumulate. Automatic air vent valves are effective.
⑨ Water pipe	Use pipes that allow for easy air purging, and provide adequate insulation.
⑩ Drain valve	Install drain valves so that water can be drained for servicing.

#### \* Installing a freezing prevention heater

- ① In cold areas (where the outside temperature drops below freezing), provide a freezing prevention heater at all local pipes to prevent spontaneous freezing.
- ② After the heater is installed, check outside temperature +25°C is ensured at the inlet/outlet pipe joint section (at outside temperature -25°C, joint section 0°C or higher).
- ③ Depending on the local piping material, prevent overheating by selecting a self temperature adjustment type heater or other method.

#### Heater installation example

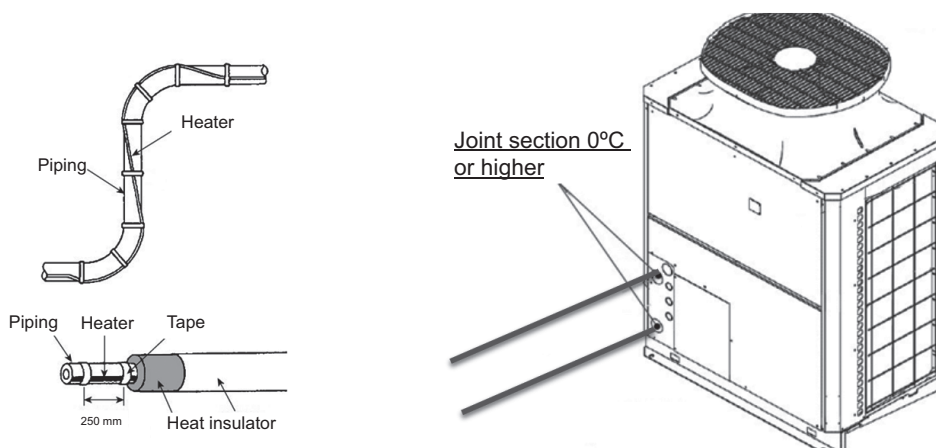



\* 3-way valve installation

Please connect 3-way valve on the lower part of the storage tank except when the unit is in operation. Anti-freezing operation will keep the water in the tank circulated and water storage tanks can become thermally stratified.

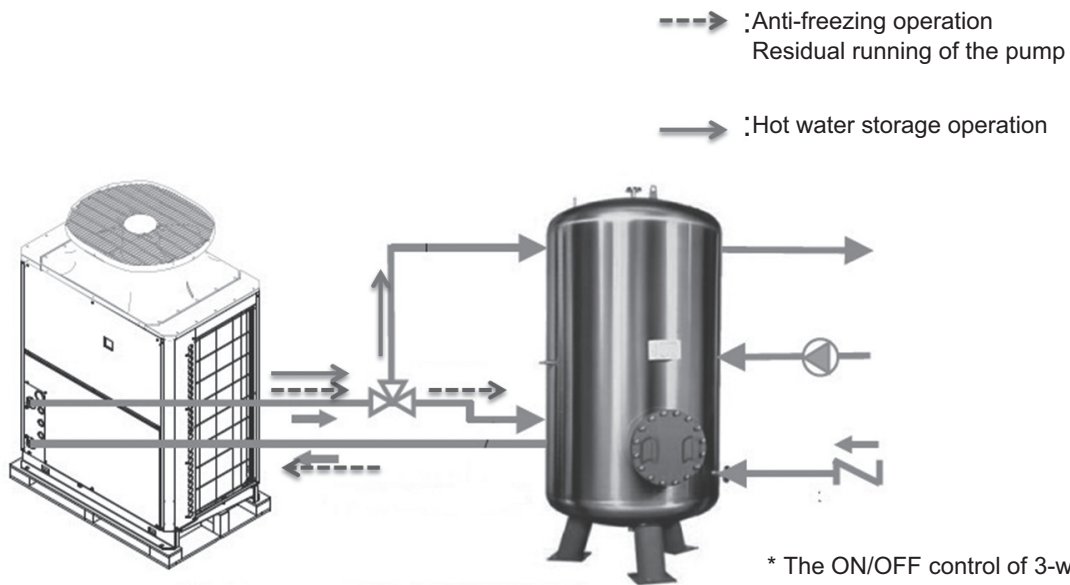

\* The ON/OFF control of 3-way valve depends on the output type "(r) EXTERNAL DEVICE" on page 75.

**2. Notes on pipe corrosion**

**Water treatment and water quality control**

Poor-quality circulating water can cause the water-side heat exchanger to scale up or corrode, reducing heat-exchange performance. Properly control the quality of the circulating water.

- Removing foreign objects and impurities in the pipes  
During installation, keep foreign objects, such as welding and sealant fragments and rust, out of the pipes.

• Water Quality Control

(1) Poor-quality water can corrode or scale up the heat exchanger. Regular water treatment is recommended.

Water circulation systems using open heat storage tanks are particularly prone to corrosion.

When using an open heat storage tank, install a water-to-water heat exchanger, and use a closed-loop circuit on the air-conditioner side. If a water supply tank is installed, keep contact with air to a minimum, and keep the level of dissolved oxygen in the water no higher than 1 mg/ℓ.

**(2) Water quality standard**

Items		Higher mid-range temperature water system Water Temp. > 60°C	Make-up water criteria (with secondary side control enabled) Water Temp. > 60°C	Tendency	
		Recirculating water	Recirculating water	Corrosive	Scale-forming
Standard items	pH (25°C)	6.5 ~ 8.0	6.5 ~ 8.0	○	○
	Electric conductivity (mS/m) (25°C)	30 or less	30 or less	○	○
	(μs/cm) (25°C)	[300 or less]	[300 or less]		
	Chloride ion (mg Cl <sup>-</sup> /ℓ)	30 or less	30 or less	○	
	Sulfate ion (mg SO <sub>4</sub> <sup>2-</sup> /ℓ)	30 or less	30 or less	○	
	Acid consumption (pH4.8) (mg CaCO <sub>3</sub> /ℓ)	50 or less	50 or less		○
	Calcium hardness (mg CaCO <sub>3</sub> /ℓ)	6.5 ≤ pH ≤ 7.5 : 90 or less 7.5 ≤ pH ≤ 8.0 : 50 or less	250 or less		○
Ionic silica (mg SiO <sub>2</sub> /ℓ)	30 or less	30 or less		○	
Reference items	Iron (mg Fe/ℓ)	0.3 or less	0.3 or less	○	○
	Copper (mg Cu/ℓ)	0.1 or less	0.1 or less	○	
	Sulfide ion (mg S <sup>2-</sup> /ℓ)	Not to be detected	Not to be detected	○	
	Ammonium ion (mg NH <sub>4</sub> <sup>+</sup> /ℓ)	0.1 or less	0.1 or less	○	
	Residual chlorine (mg Cl/ℓ)	0.1 or less	0.1 or less	○	
	Free carbon dioxide (mg CO <sub>2</sub> /ℓ)	10.0 or less	10.0 or less	○	

Reference: Guideline of Water Quality for Refrigeration and Air Conditioning Equipment. (JRA GL02E-1994)

(3) Please consult with a water quality control specialist about water quality control methods and water quality calculations before using anti-corrosive solutions for water quality management.

(4) When replacing an air conditioner (including when only the heat exchanger is replaced), first analyze the water quality and check for possible corrosion.

Corrosion can occur in water systems in which there has been no signs of corrosion. If the water quality level has dropped, adjust the water quality before replacing the unit.

**(5) Suspended solids in the water**

Sand, pebbles, suspended solids, and corrosion products in water can damage the heating surface of the heat exchanger and cause corrosion. Install a good quality strainer (60 mesh or better) at the inlet of the unit to filter out suspended solids.

**(6) Connecting pipes made from different materials**

If different types of metals are placed in direct contact with each other, the contact surface will corrode.

Install an insulating material between pipes that are made of different materials to keep them out of direct contact with each other.

### 3. Water pipe hole size and location

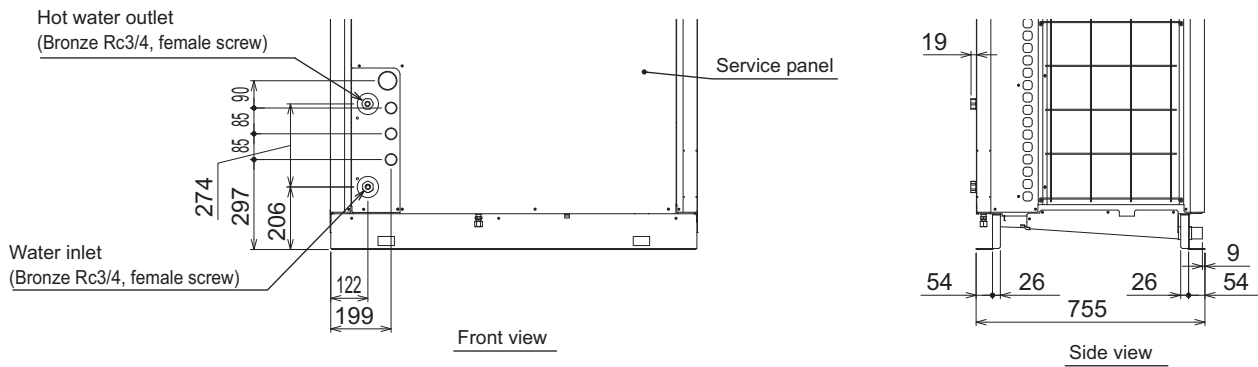

### 4. Pipe gradient and air venting valve (Outlet hot water pipe)

During the hot water storage operation, the air dissolved in the water is discharged in the form of bubbling from the outlet hot water pipe to quickly raise low-temperature water to the required temperature. When the air accumulates in the pipe, the resistance of the water circuit will increase and the flow rate will extremely decrease. Because of this, an installation of automatic air venting valves is required when there is a pipe that slopes down in the outlet hot water pipe.

Install the pipe with an upward gradient of 1/200 or more toward the air vent to prevent air accumulation in the pipe. Also, install air venting valves to the places where air can accumulate. The installation example is shown below.

Note:

- If the crosscut pipe is located lower than the hot water outlet of the heat pump unit, raise the pipe near the unit and install an automatic air venting valve.

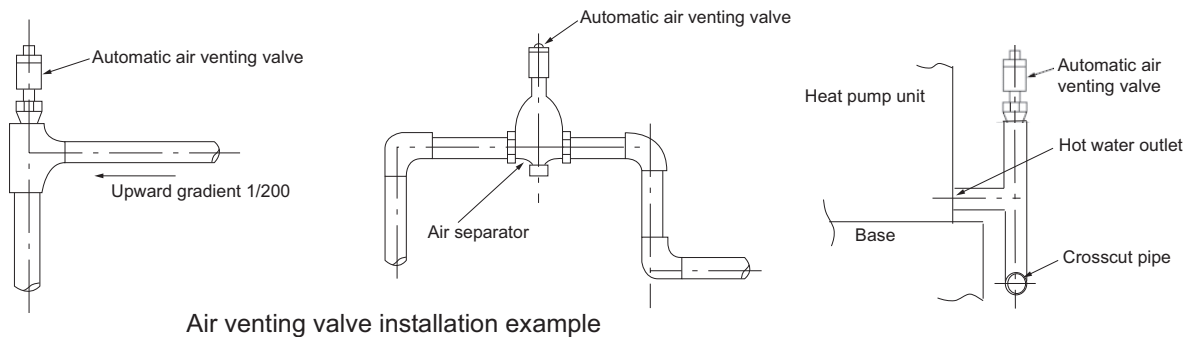

Air venting valve installation example

### 5. Outlet check valve (When installing multiple units)

When connecting multiple units with pipes in parallel, install a check valve at the outlet pipe of each unit. If a check valve is not installed, a circuit in which warm water flows back will be created in some units during the defrost cycle or abnormal stop, and other units will come to an abnormal stop due to sudden change of the inlet water temperature.

## [8] Using the Unit in Sub-freezing or Snowy Conditions

In areas where temperature drops to freezing during the periods of non-use, blow the water out of the pipes or fill the pipes with anti-freeze solution.

Not doing so may cause the water to freeze, resulting in burst pipes and damage to the unit or the furnishings.

In areas where temperature can drop low enough to cause the water in the pipes to freeze, operate the unit often enough to prevent the water from freezing.

Frozen water in the water circuit may cause the water to freeze, resulting in burst pipes and damage to the unit or the furnishings.

In areas where temperature drops to freezing, use an anti-freeze circuit and leave the main power turned on to prevent the water in the water circuit from freezing and damaging the unit or causing water leakage and resultant damage to the furnishings.

- Remove the snow off the unit before switching on the ON/OFF switch.
- In areas where the outside air drops below freezing, leave the main switch turned on even when the unit will not be operated for four days or longer. Leave the switch on the water circulation pump turned on if the pump is connected to a separate circuit.
- If the unit is left turned off for a while (e.g., overnight) when the outside temperature drops below freezing, the water in the water circuit will freeze and damage the pipes and the heat exchanger.
- The recommended electric circuit has an anti-freeze circuit. For this circuit to function, the main power must be turned on.
- If the water circulation pump is connected differently from the recommended way, make sure the circuit has some type of anti-freeze function\*.  
(\* A function that automatically operates the water circulation pump to prevent the water in the circuit from freezing when the water temperature drops.)

In cold areas (where the lowest outside temperature drops below freezing), if power is not supplied while the unit is stopped during winter, make sure to completely drain water from the piping. Failure to do so may cause the residual water to freeze, resulting in damage to the heat exchanger.

Before using the unit, perform a test run such as water fill test or air bleeding test again.

### Drainage method

#### Procedure

1. Disconnect the outlet pipe.
2. Disconnect the inlet pipe.
3. Open the drain trap at the T-shaped part.
4. Completely remove water by blowing compressed air or nitrogen (cylinder) of 0.5 to 0.6 MPa into the outlet pipe.

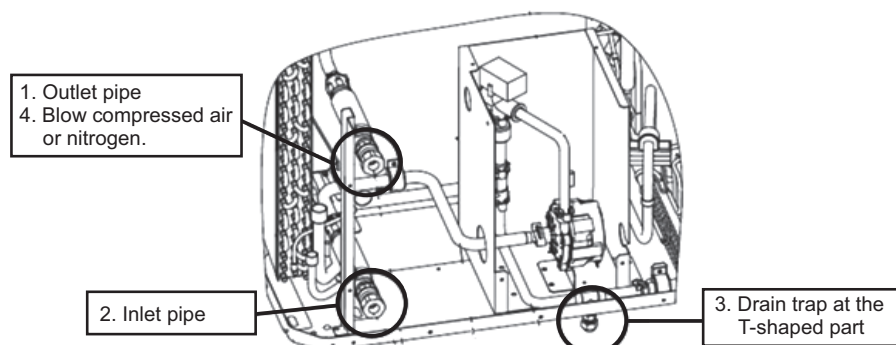

**[9] Secondary side control system**

When employing an indirect heat exchanger system using a separately sold Q-1SCK, be careful with regard to the following points.

Install the Q-1SCK (flow sensor and temperature sensor) in the secondary side circuit as shown below to perform control.

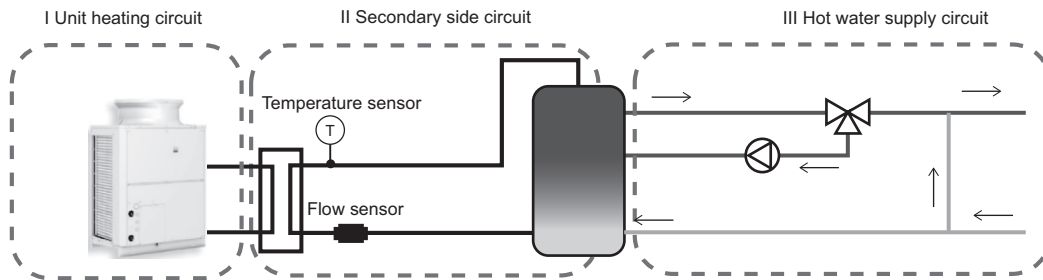

**(1) Notes on configuring and selecting components**

- ① Points to note for secondary side water piping
  - I Details on components in the unit heating circuit
    - \* For details, refer to page 33.
  - II Details on components in heat exchanger heating circuit

Schematic Piping Diagram and Piping System Components for secondary circuit

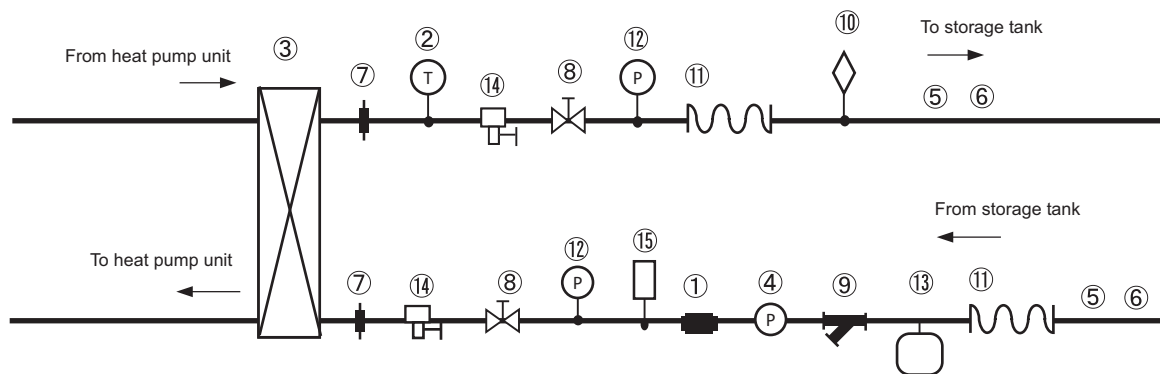

No.	Component	Application	Remarks and notes on selecting and installing components
①	Flow sensor (Optional parts)	Measures and controls the secondary side flow rate.	Be sure to install this component between the downstream of the flow rate adjustment device and the heat exchanger.
②	Temperature sensor (Optional parts)	Measures and controls the secondary side outlet hot water temperature.	Install this component at the outlet of the heat exchanger.
③	Plate heat exchanger	Exchanges heat between hot water output from the unit and water input from the tank.	Select a heat exchanger that is appropriate for the capacity.
④	Pump + Flow rate adjustment device	Outputs hot water from the secondary side and adjusts the flow rate.	Select a pump and flow rate adjustment device that are suitable for the system. Install them at the lower outlet of the tank.
⑤	Water piping	Water flow channel	Be sure to perform insulation work. Select pipes that allow for easy air bleeding.
⑥	Anti-freeze heater	Prevents pipe damage due to freezing of the water circuit.	This component needs to be installed in a location where an ambient temperature may fall to 0°C or less.
⑦	Union joint	Improves the workability of replacing equipment.	Install these components in the two places of the chilled water passage section and the high temperature water passage section to enable replacement.

No.	Component	Application	Remarks and notes on selecting and installing components
⑧	Valve	Improves the workability of cleaning the heat exchanger and replacing parts.	Install these components in the two places of the chilled water passage section and the high temperature water passage section to enable replacement.
⑨	Strainer	Prevents foreign materials from entering into the heat exchanger.	Install a strainer with 60 mesh or better near the heat exchanger.
⑩	Air vent valve	Bleeds air from the pipe.	Install air vents in places where there is a risk of air accumulating.
⑪	Flexible joint	Prevents the propagation of vibration.	These components need to be installed in consideration of the pipe load as pipes are easily damaged by bending.
⑫	Water pressure gauge	Used to check the operation status.	Attach this component to each piping section to check the water pressure.
⑬	Expansion tank	Absorbs excessive water pressure due to expansion caused by a rise in temperature.	Select an expansion tank that is suitable for the system.
⑭	Drain valve	Improves workability of replacing equipment.	Install these components in the two places of the chilled water passage section and the high temperature water passage section to enable replacement.
⑮	Safety valve	Prevents rupturing of the water circuit.	Be sure to provide an escape pipe to prevent discharged water from spraying on passersby.

② Selection criteria for heat exchanger

Step 1 Determination of prerequisites for selection

I Heat exchanger capacity 40000 W

II Estimation of outlet hot water and inlet water temperatures

As a guide, select a heat exchanger of which the temperature difference between the high temperature section and the low temperature section will be 5°C or below.

II-1 Outlet hot water temperature (when secondary side outlet hot water temperature is set to 65°C (setting at the time of shipment))

- Secondary side circuit outlet hot water temperature: 65°C
- Unit outlet hot water temperature: 70°C

II-2 Inlet water temperature

- Secondary side inlet water temperature: 10°C
- Unit inlet water temperature: 15°C

III Used flow rate

$$(40000 \text{ W}) / ((70 - 15)^\circ\text{C} / 4200 \text{ J/kg}\cdot\text{K}) \times 60 \text{ s} = 10.4 \text{ kg/min} \approx 10.4 \text{ l/min}$$

Step 2 Determination of model

Notes on selection

- Select a heat exchanger that allows water to pass through both of the flow channels.
- Select a heat exchanger so that the pressure applied to the heat exchanger in the on-site system will not exceed the maximum operating pressure of the heat exchanger.
- Select a heat exchanger that allows flowing at a flow rate of maximum 30 l/min.
- Select a heat exchanger with a capacity of at least 40000 W.
- Ensure that the shearing stress at the flow rate to be used will be 16 Pa or more. (Refer to step 4.)

\* To increase the shearing stress:

- When the area per plate is equal, select a vertically long heat exchanger.
- Select a heat exchanger of which NTU is high (although the heat transfer capacity improves as NTU increases, the pressure loss becomes high).

**Step 3 Determination of specifications of the heat exchanger**

Determine the model of heat exchanger and number of plates in consultation with the heat exchanger manufacturer based on the above requirements.

\* To determine the number of plates, calculate the number of plates while referring to the example below. Values to use when determining the number of plates:

- ① Overall heat transfer coefficient of corresponding heat exchanger
- ② Heat transfer area per plate

**Calculation method**

A Obtain the data of ① and ② from the heat exchanger manufacturer.

B Estimate the number of plates of the heat exchanger.

C Check that the number of transfer units for the corresponding number of plates matches between NTU1 and NTU2 (NTU1=NTU2).

If they are matched, select a heat exchanger having the corresponding number of plates. If they are not matched, change the number of plates and then return to B to perform the calculation again.

$$NTU1 = \frac{\Delta T1}{\Delta T} \quad NTU2 = \frac{K \times A}{V \times C}$$

$\Delta T1$ : Temperature difference between inlet and outlet  
 $\Delta T$ : Temperature difference of high temperature part (low temperature part)  
 $K$ : Overall heat transfer coefficient (W/m<sup>2</sup>K)

$A$ : Total heat transfer area (m<sup>2</sup>)  
 $G$ : Total mass flow rate (kg/s)  
 $C$ : Specific heat (J/kgK)

**Step 4 Calculation of the shearing stress**

Calculate the shearing stress using the following method.

Values required for calculation

- Relationship between flow rate and pressure loss of corresponding heat exchanger (Obtain the data from the heat exchanger manufacturer.)

**Calculation method**

Calculate the shearing stress using the following formula.

$$\tau = \frac{\Delta P}{4} * \frac{\text{Representative length of 1 channel}}{\text{Effective length}}$$

Effective length:

Length between water inlet and water outlet (refer to the figure on the right)

Representative length of 1 channel:

Distance between plates (refer to the figure on the right) × 2

$\Delta P$ : Pressure loss

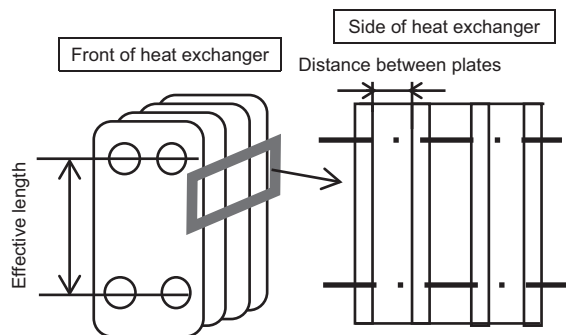

A shearing stress of 16 Pa or higher is required to reduce the amount of scale that adheres.

If the shearing stress is low:

- Select a vertically short shape.
- Change the shape of the plates.

Reselect a heat exchanger that will increase the shearing stress by following methods described above.

③ Configuration method and selection criteria of flow rate adjustment device

In this system, a flow rate adjustment device is installed in the secondary side circuit to perform secondary side flow rate adjustment control by outputting 0 to 10 V from the unit.

\* 10-V power supply is not supplied.

The following shows a system configuration example of the flow rate adjustment device and notes on the system configuration.

The following three system types are recommended as flow rate adjustment devices:

1. System using a three-way valve
2. System using a two-way valve
3. System using an inverter

**1. System using a three-way valve**

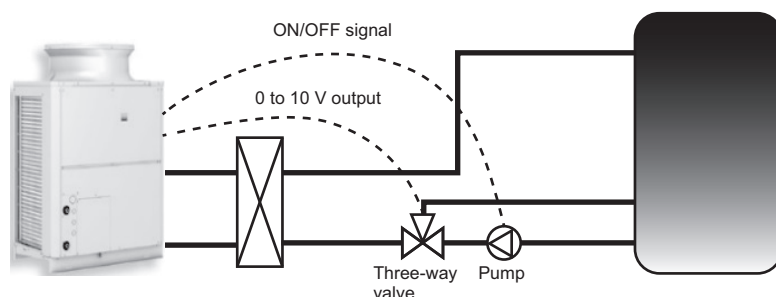

Overview of system

This system has a pump provided at the outlet of the tank and a three-way valve provided downstream of the pump, and adjusts the flow rate by controlling the opening and closing of the three-way valve.

	Flow rate output device	Flow rate adjustment device
	Pump	Three-way valve
Wiring connection places	1-3 of CN512 of control board (ON/OFF output)	Sub box terminal block No. 10, 11, 12

**Notes on selection method and system configuration**

**Notes on pump selection and connection**

- Calculate the total pump head according to the system at the site and then select a pump capable of outputting the minimum flow rate of about 3 l/min and maximum flow rate of about 30 l/min with the necessary pump head for the piping at the site.
- When selecting the pump, please note that output at a high flow rate will not occur if the flow rate with the pump head of the system at the site is low, and output at a low flow rate will not occur if the flow rate is too high.
- Be sure to check that the flow rate becomes 20 to 30 l/min at the maximum output during a flow rate adjustment test run (refer to page 92).  
For how to check the flow rate, refer to page 93.
- \* If the flow rate is not within the range of 20 to 30 l/min, select a different pump or adjust the maximum frequency using an inverter, etc. so that the maximum flow rate of 20 to 30 l/min is achieved.
- \* To select a proper pump, first select a pump that supports slightly high flow rate, and then adjust the frequency with an inverter so that the flow rate becomes 20 to 30 l/min at the maximum output.  
(In that case, an inverter is necessary to be prepared separately.)

**Notes on three-way valve selection and connection**

- Use a valve that is capable of adjusting the flow rate with a 0 to 10 V input.
- Calculate the Cv value and select a valve that supports an appropriate rate.
- Select a valve of which the ratio of the maximum flow rate and the minimum flow rate will be at least 1:10.
- Place the three-way valve downstream of the pump. Connect one outlet to the heat exchanger. Connect the other outlet to the lower part of the tank.
- Carefully read the instruction manual and use the three-way valve in accordance with the usage procedures.



## 2. System using a two-way valve

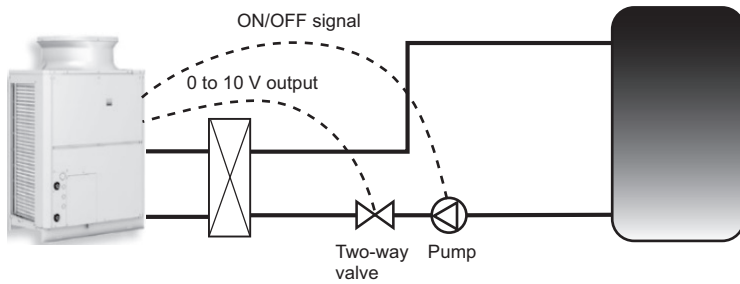

### Overview of system

This system has a pump provided at the outlet of the tank and a two-way valve provided downstream of the pump, and adjusts the flow rate by controlling the opening and closing of the two-way valve.

	Flow rate output device	Flow rate adjustment device
	Pump	Two-way valve
Wiring connection places	1-3 of CN512 of control board (ON/OFF output)	Sub box terminal block No. 10, 11, 12

### Notes on pump selection and connection

Select a pump in the same way as for a system with a three-way valve.

### Notes on two-way valve selection and connection

- Use a valve that is capable of adjusting the flow rate with a 0 to 10 V input.
- Calculate the Cv value and select a valve that supports an appropriate rate.
- Select a valve of which the ratio of the maximum flow rate and the minimum flow rate will be at least 1:10.
- There are various kinds of two-way valve (such as ball valve, butterfly valve, and globe valve), and there are valves suitable for flow rate adjustment and valves that are not suitable for flow rate adjustment. Therefore be sure to select a two-way valve of a kind capable of precisely controlling the flow rate, such as a butterfly valve or globe valve.
- Place the two-way valve downstream of the pump.
- Carefully read the instruction manual and use the two-way valve in accordance with the usage procedures.

## 3. System using an inverter

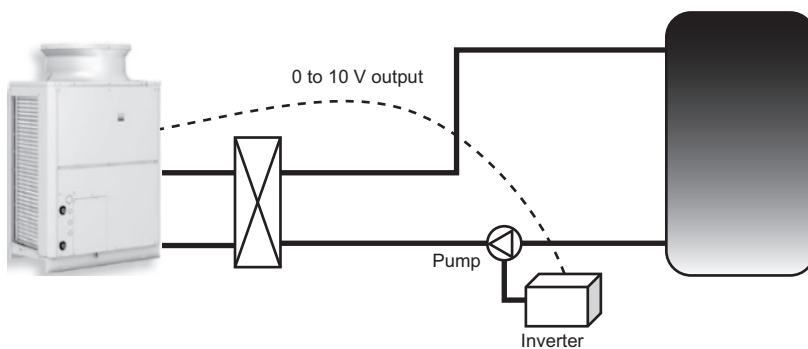

### Overview of system

This system has a pump provided at the outlet of the tank and an inverter connected to the pump, and adjusts the flow rate by changing the frequency of the inverter.

	Flow rate output device	Flow rate adjustment device
	Pump	Inverter
Wiring connection places	-	Sub box terminal block No. 10, 11, 12

### Notes on pump selection and connection

Select a pump in basically the same way as for a system with a three-way valve or two-way valve.

- Select a pump that can be used also at a low frequency (6 Hz or less).  
(The motor may be seized depending on the pump selected as this control is performed at a low frequency.)
- Select a pump of which flow rate at 100% output is between 20 to 30 ℓ/min.

### Notes on inverter selection and connection

- The inverter needs to be able to adjust output with a 0 to 10 input.
- Select an inverter that will not cause the seizing of the motor.
- Configure the settings so that the flow rate on the secondary side will become 0 ℓ/min when the unit is not operating.
- Carefully read the instruction manual and use the inverter in accordance with the usage procedures.

**(2) Notes on other piping work**

**① Notes on installation location of secondary side circuit**

Install the secondary side heat exchanger, secondary side thermistor, secondary side flow sensor, and secondary side pump indoors as shown in the figure for the secondary side circuit system. Also, take measures so that the piping will not freeze.

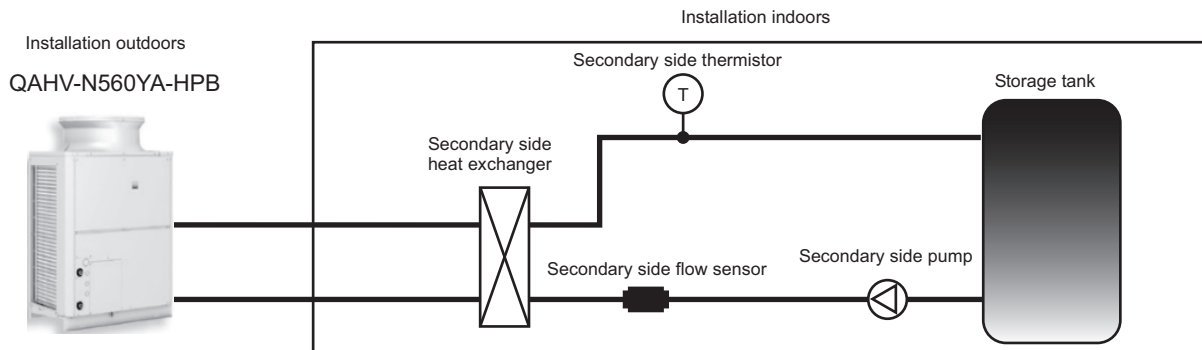

**② Notes on hot water supply piping**

Be sure to connect the hot water supply piping to the lower part of the storage tank. If you connect it to the unit inlet pipe, an abnormal stop (high pressure or gas cooler outlet temperature) may occur or the outlet hot water temperature may decrease due to the sudden change of the inlet water temperature (5 K/min or more instantaneously or 1 K/min or more consecutively) during operation.

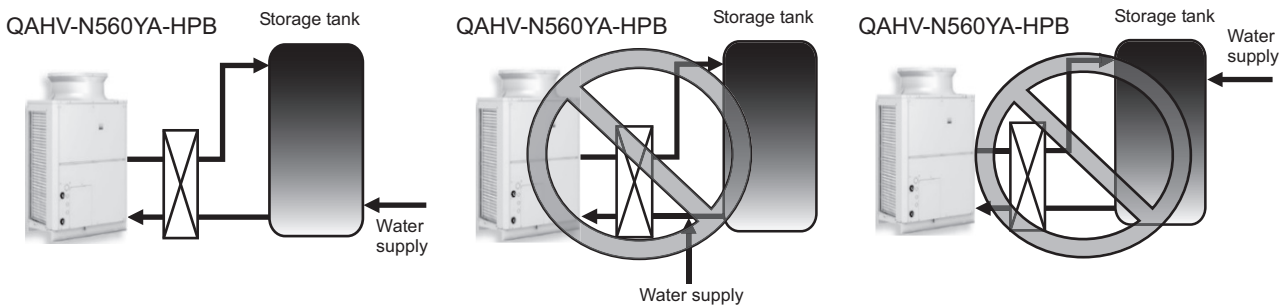

**③ About anti-freezing operation**

This unit performs anti-freezing operation. Furthermore, the control method can be changed according to the system at the site. The following two items can be changed.

**1. Prevent disturbance of thermal stratification in the tank**

To prevent the disturbance of the thermal stratification in the tank while the indoor temperature is sufficiently high, set the item code 1514 to "1" so that the judgment criterion for starting the anti-freezing operation of the secondary side circuit matches with the secondary side circuit water temperature criterion.

**Setting procedure and operation overview**

Setting procedure		Operation
Item code 1514	0 (Initial setting)	Performs anti-freezing operation in the secondary side circuit when the water temperature in the unit side circuit becomes the standard value or below.
	1	Performs anti-freezing operation in the secondary side circuit when the water temperature in the secondary side circuit becomes the standard value or below.

**2. Purpose and application: Prevent piping freezing when the secondary side control is used**

If the compressor is not run during the anti-freezing operation in the secondary side control system, there is a risk of the piping of the primary side freezing, so set SW2-5 to "ON" so that the compressor runs during the anti-freezing operation.

**Setting procedure and operation overview**

Setting procedure		Operation
SW2-5	OFF (Initial setting)	The compressor does not operate when the anti-freezing operation is performed.
	ON	The compressor operates when the anti-freezing operation is performed.

**④ When connecting multiple units**

To connect multiple units, configure one secondary side circuit system for each unit as shown in the figure below. (Install a heat exchanger, flow sensor, and thermistor for each unit.)

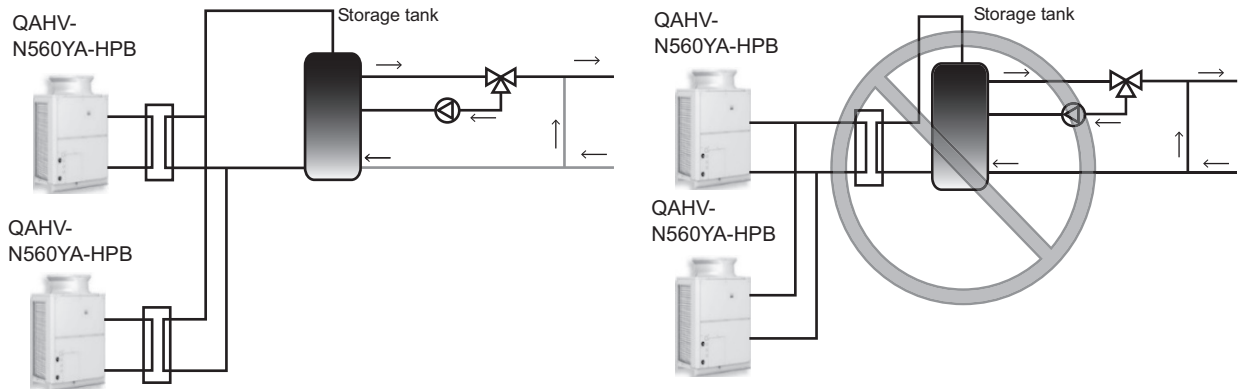

**(3) Optional parts**

The flow sensor and thermistor in the system are sold separately.

For the pipe connection method, refer to the manuals of the optional parts (Q-1SCK).

Secondary circuit kit Q-1SCK

The size and length noted are approximate.

Parts	Shape	Specification
Thermistor		A: 157 mm B: 42 mm C: 54 mm D: 48 mm
Flow sensor		A: 129 mm B: R3/4 C: R3/4 Wiring length: 1.9 m

**(4) Setting method for secondary side control**

After configuring the secondary side control system, perform the following operation to perform the secondary side control operation.

1. Set the digital setting item "121" to 1 (for details on the operating procedure, refer to page 28).
2. Perform a water flow rate adjustment operation (for details, refer to "Water flow rate adjustment operation (when the secondary side control is enabled)" (page 92)).

---

### III Unit Components

[1] Unit Components and Refrigerant Circuit .....	47
[2] Control Box of the Unit.....	50
[3] Unit Circuit Board.....	52



**[1] Unit Components and Refrigerant Circuit**

**1. Unit Components**

(1) Front view

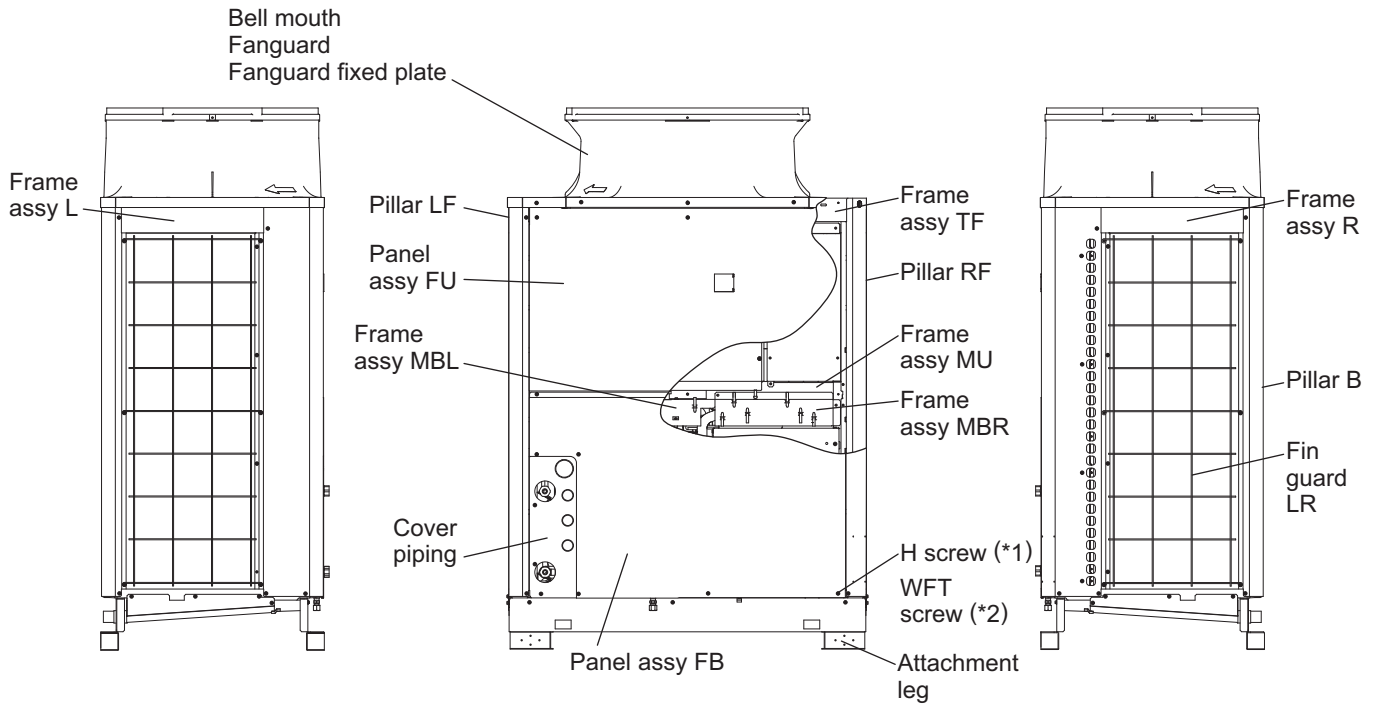

(2) Rear view

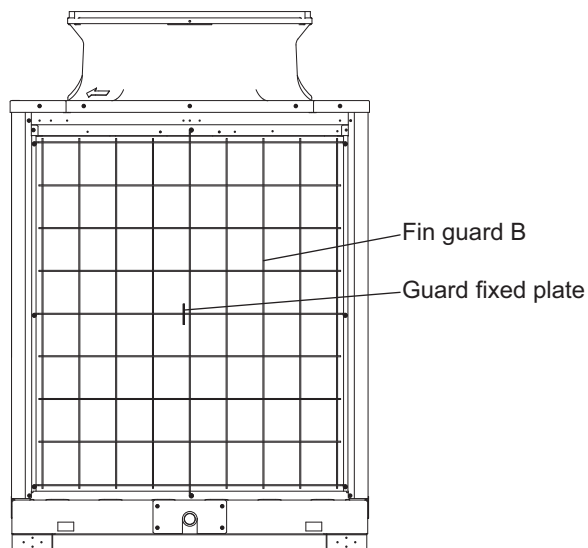

(3) Fan

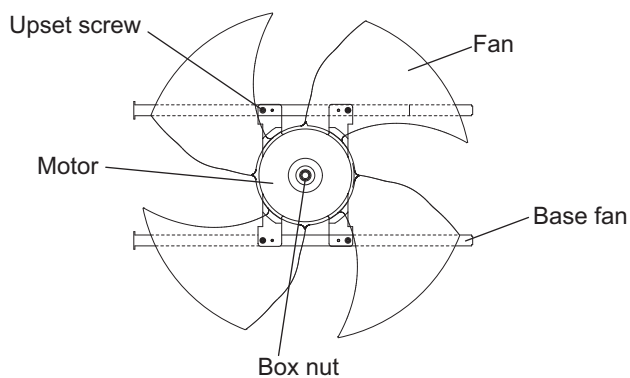

\*1 Each unit requires 47 H screws.

\*2 Each unit requires 30 WFT screws.

2. Refrigerant circuit

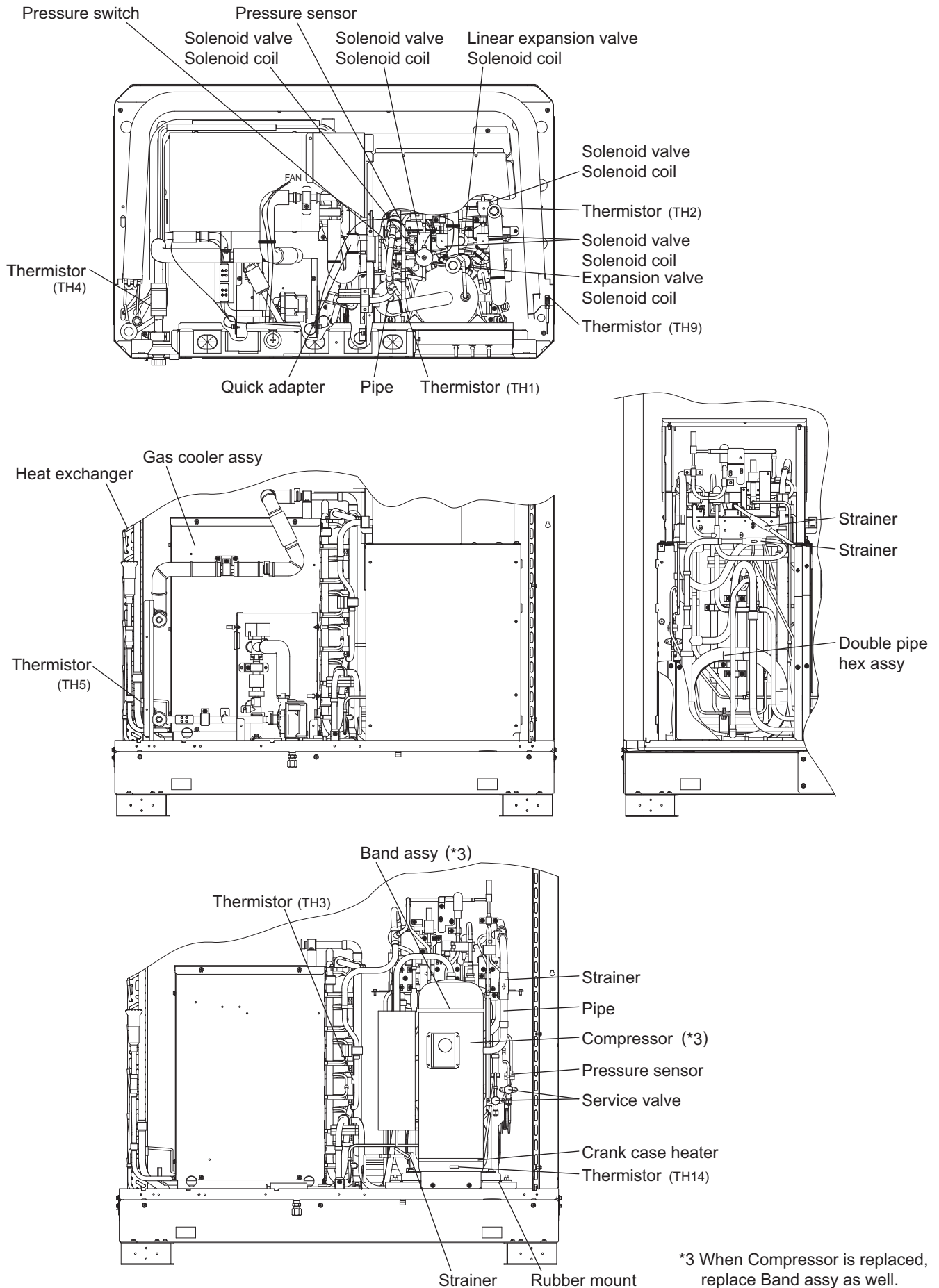

\*3 When Compressor is replaced, replace Band assy as well.

3. Water circuit

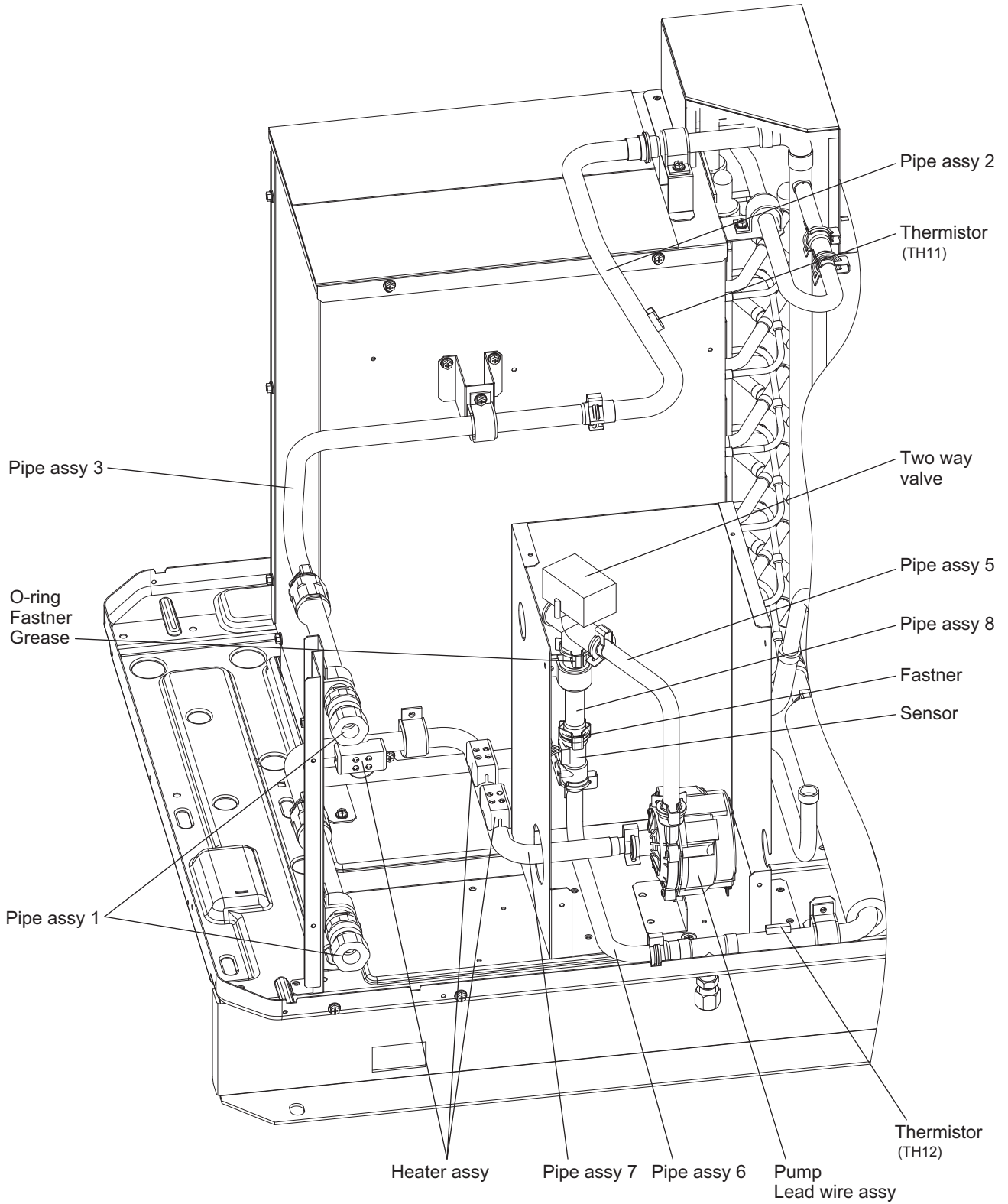



## [2] Control Box of the Unit

### 1. Main circuit control box

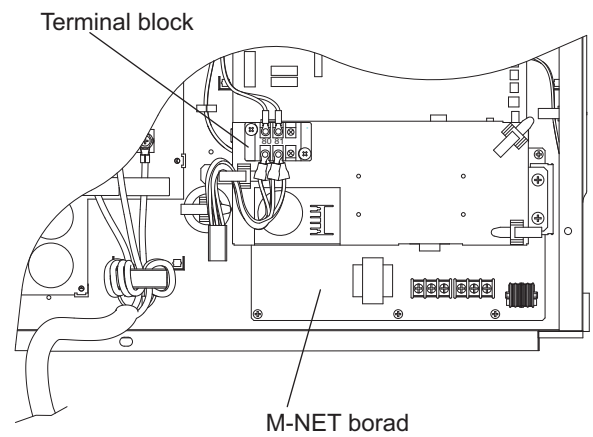
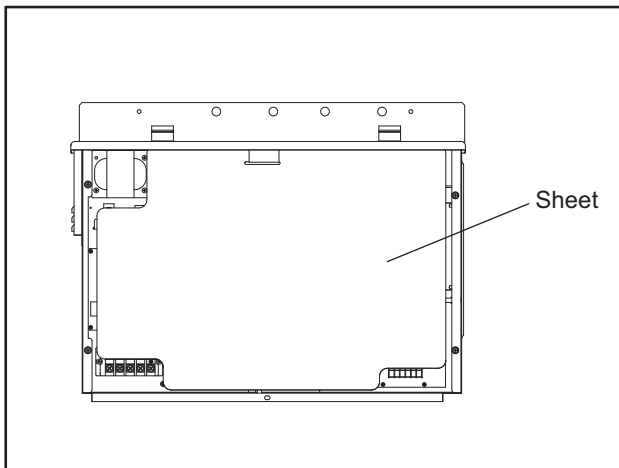
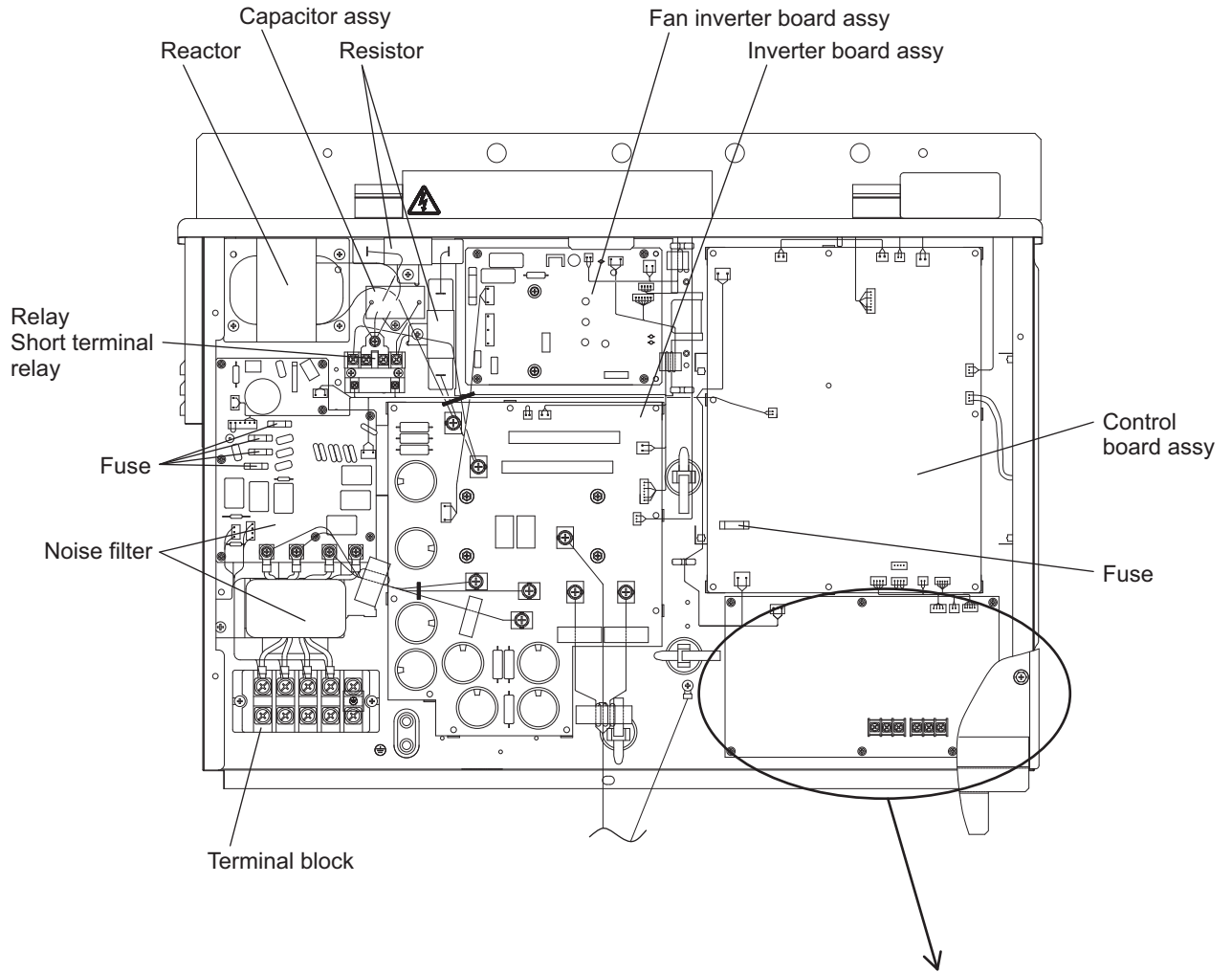

**2. Sub circuit control box**

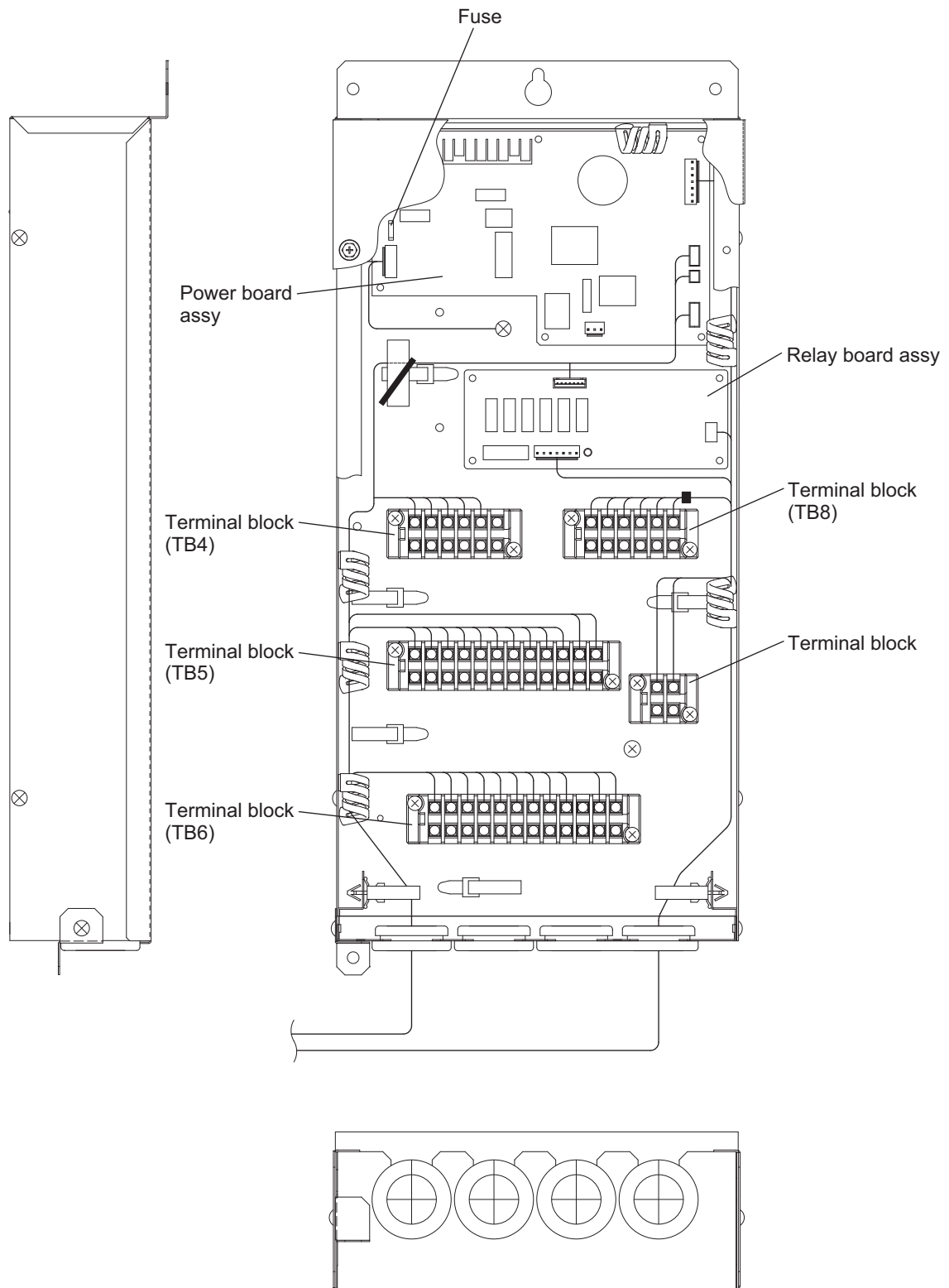

**Note**

- 1) Exercise caution not to damage the bottom and the front panel of the control box. Damage to these parts affect the waterproof and dust proof properties of the control box and may result in damage to its internal components.
- 2) Faston terminals have a locking function. Make sure the cable heads are securely locked in place. Press the tab on the terminals to remove them.

### [3] Unit Circuit Board

#### 1. Control board (MAIN board)

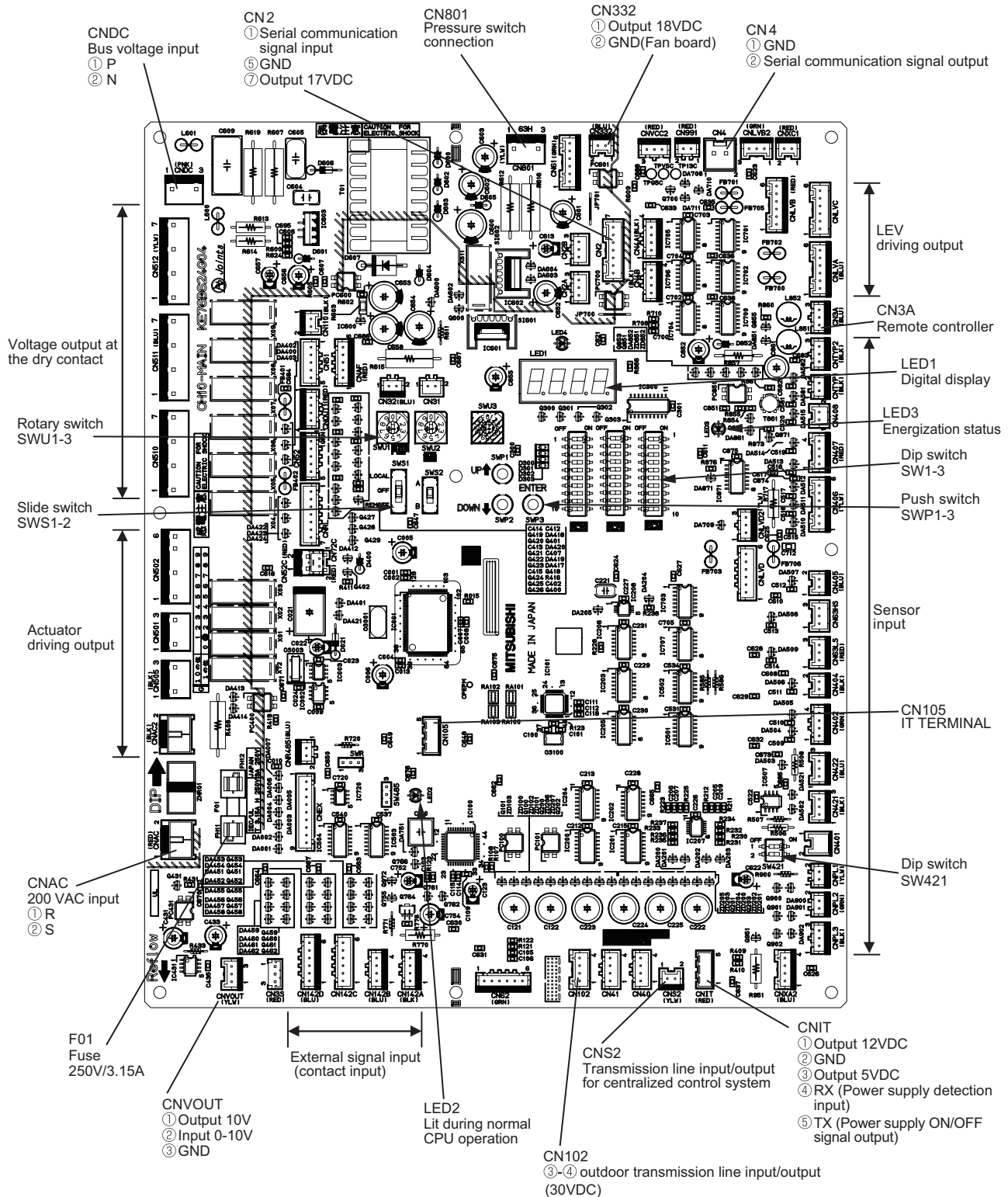

2. M-NET board

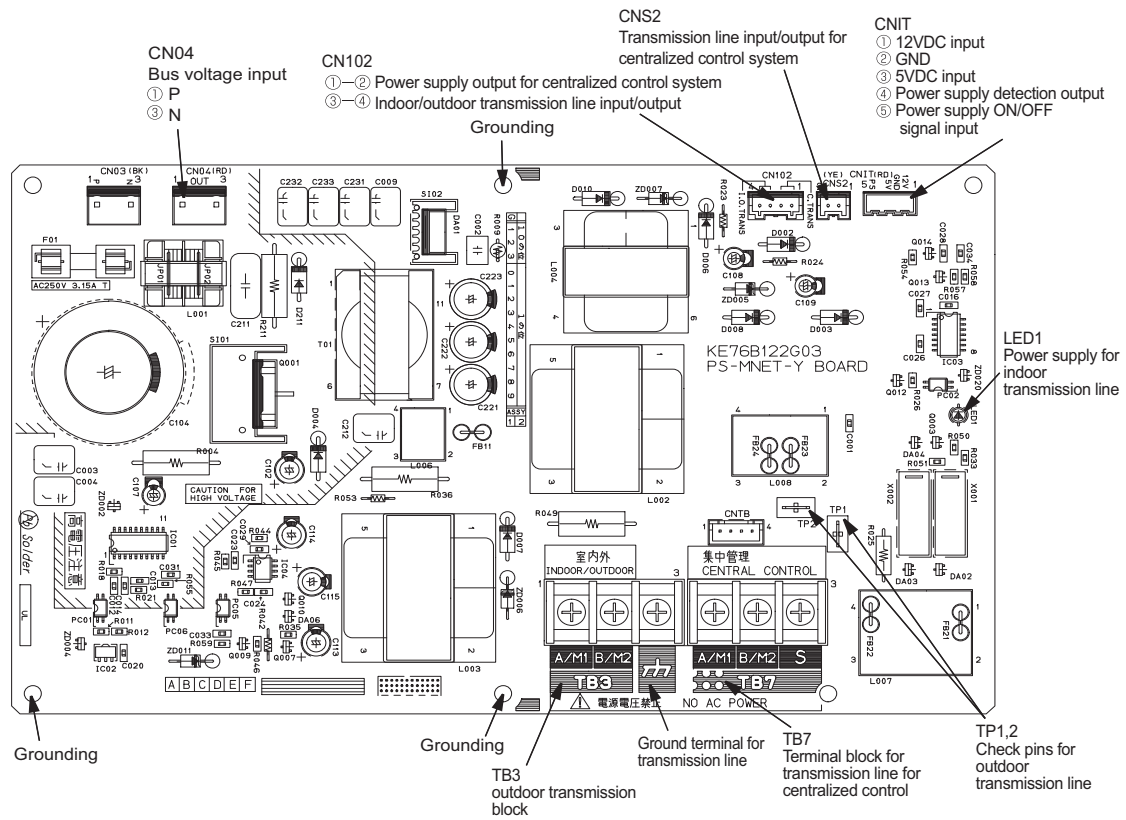

3. INV board

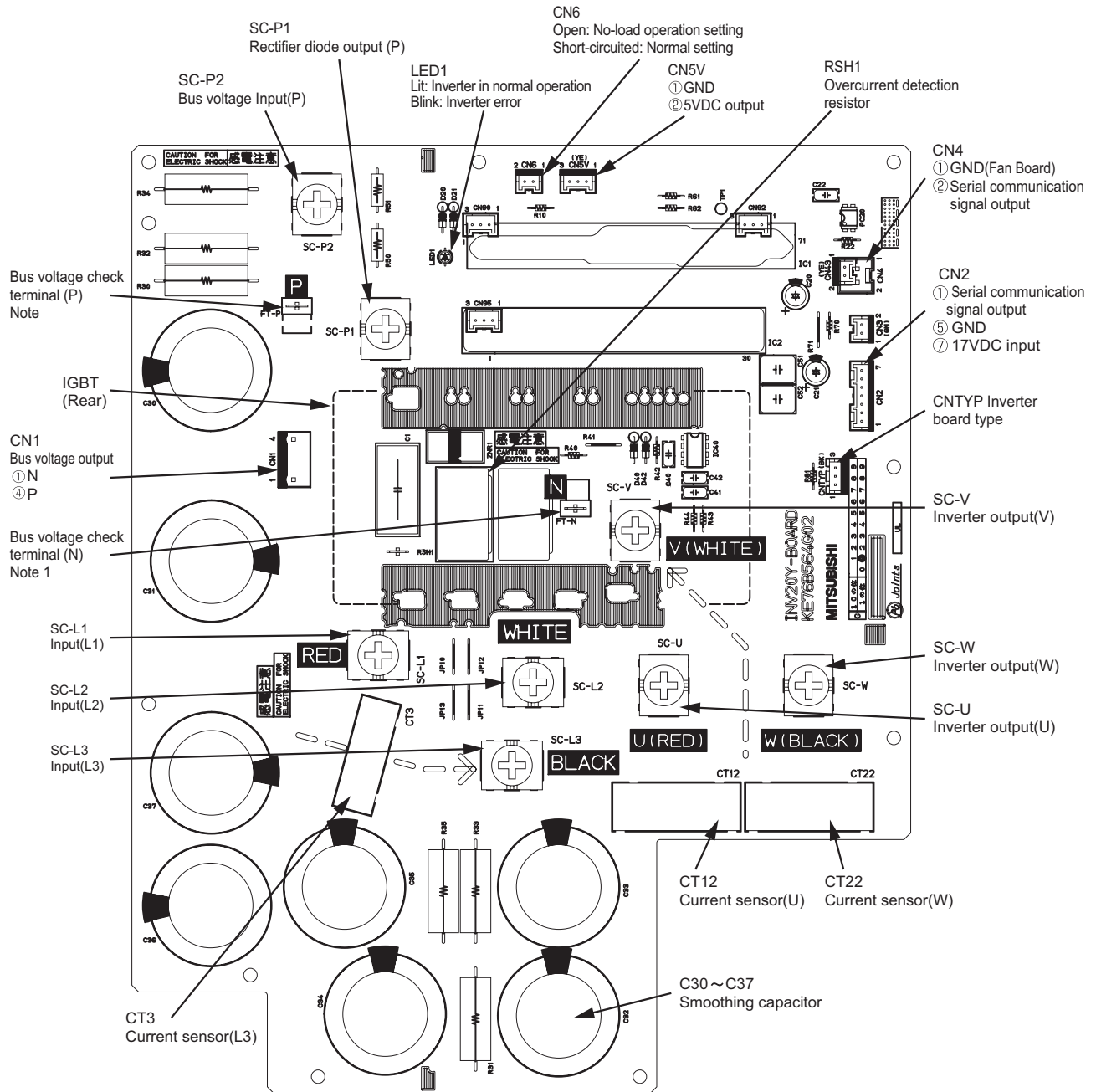

**Note**

- 1) Before inspecting the inside of the control box, turn off the power, keep the unit off for at least 10 minutes, and confirm that the voltage between FT-P and FT-N on INV Board has dropped to DC20V or less. It takes about 10 minutes to discharge electricity after the power supply is turned off.

### 4. Fan board

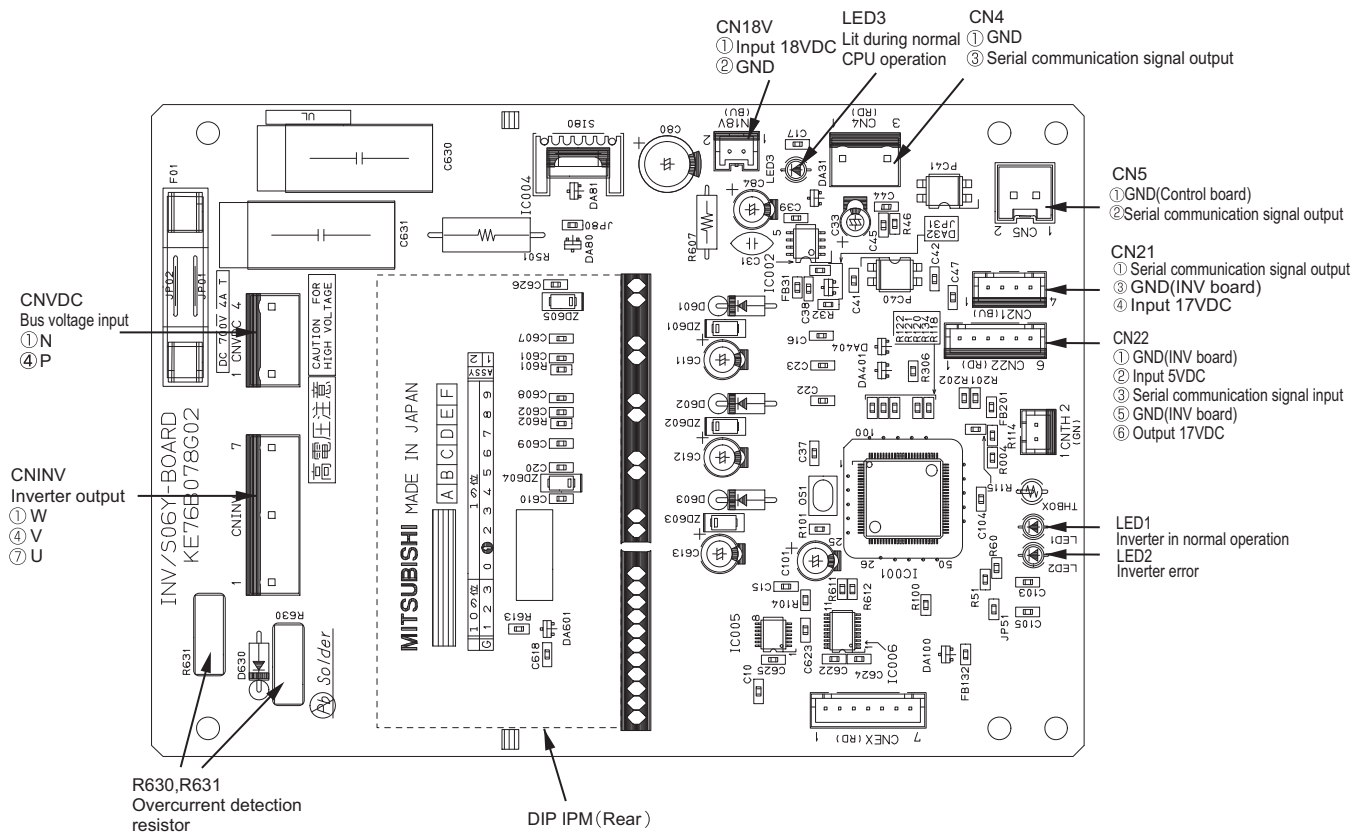

5. Noise Filter

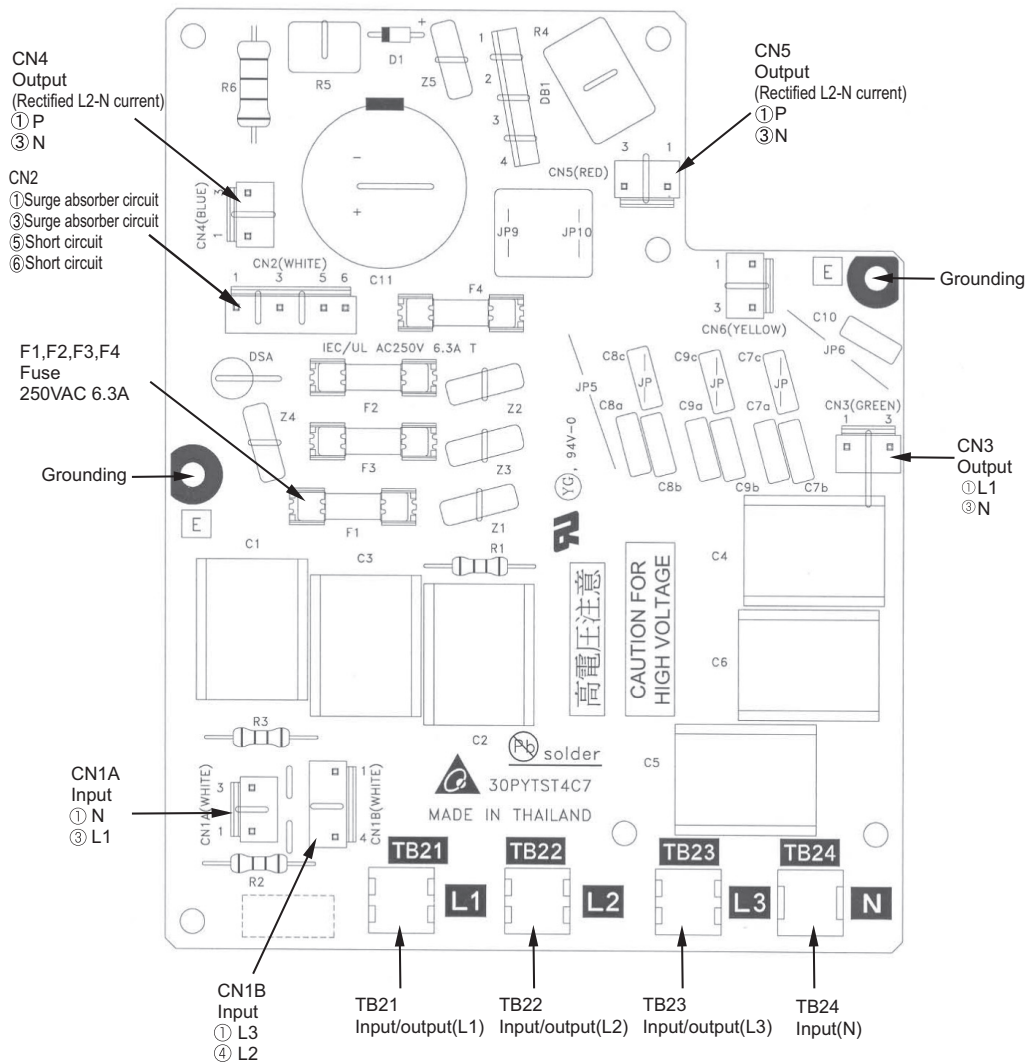

---

## IV Remote Controller

[1] Using the Remote Controller.....	59
--------------------------------------	----





## [1] Using the Remote Controller

### <1> Power ON/OFF

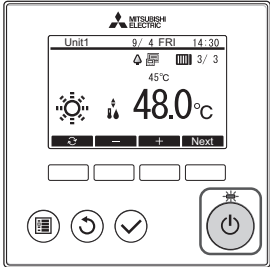
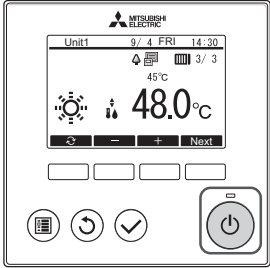
<p>During operation</p>		<p>Press the [ON/OFF] button.</p> <p>The ON/OFF lamp will light up in green, and the operation will start.</p>
<p>During stoppage</p>		<p>Pressing the [ON/OFF] button brings up a confirmation screen. When it appears, press the [F3] button.</p> <p>The ON/OFF lamp will come off, and the operation will stop.</p>

### <2> Operation mode and set temperature settings

#### Operation mode setting

Button operation

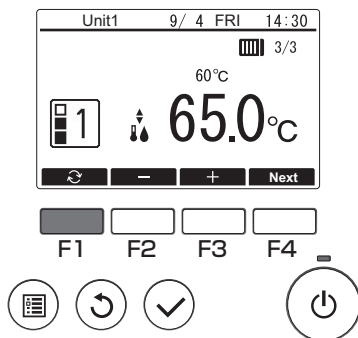

Press the [F1] button to go through the operation modes in the order of "Mode1, Mode2, and Mode3."  
Select the desired operation mode.



#### Set temperature setting

Button operation

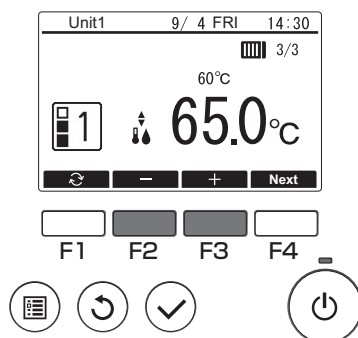

Press the [F2] button to decrease the set temperature, and press the [F3] button to increase.

## <3> Using Weekly timer

### Function description

Following settings can be used to change the operating schedule according to the day of the week.

- Set the schedule for ON/OFF, operation mode and set temperature for each day of the week.

#### Button operation

1

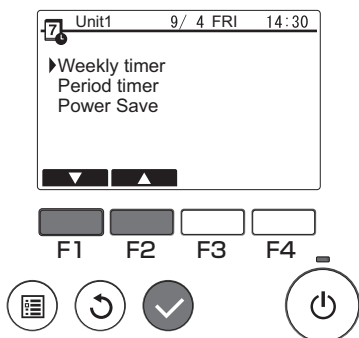

Select "Weekly timer" from the Schedule menu, and press the [Select] button.

2

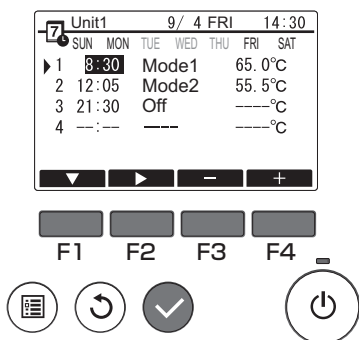

The Weekly timer screen will be displayed.

To check the operation settings:  
Press the [F1] or [F2] button to check the settings from Monday to Sunday.  
The [F4] button displays the following page.

To change the operation settings:  
Press the [F1] or [F2] button to select a day and then press the [F3] button to confirm the day to be set. (Multiple days can be selected.)  
After selecting the desired day, press the [Select] button.

3

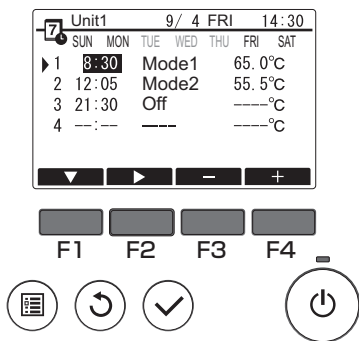

The pattern setting screen will be displayed.

Press the [F1] button to select a pattern.  
Press the [F2] button to select the item you want to change.  
Press the [F3] or [F4] button to switch to the desired setting.

Time	Set in 5-minute increments. * Hold down the button to change the value continuously.
Operation mode, Off	The options available vary depending on the connected unit. * If you select an operation mode other than Off, the connected unit will operate.
Set temperature	You can change the set temperature (in 0.5°C increments).

Weekly timer operation is disabled in the following situations:

- When Schedule is disabled
- On days when the period timer is also enabled

Weekly timer operation may not be executed depending on the system configuration.

#### Navigating through the screens

- To save the settings ..... [Select] button
- To return to the Main display ..... [Menu] button
- To return to the previous screen ..... [Return] button

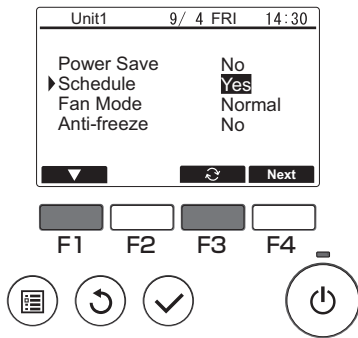

In the Operation setting screen, press the [F1] button to move the cursor to "Schedule".  
Press the [F3] button to select "Yes".

## <4> Using Period timer

### Function description

Following settings can be made to change the specified period and daily operating schedule.

- Set the schedule for ON/OFF, operation mode and set temperature.

\* If the periods specified in 1 and 2 overlap, only the period specified in 1 will be implemented.

### Button operation

1

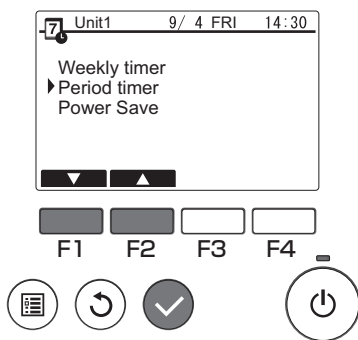

Select "Period timer" from the Schedule menu, and press the [Select] button.

2

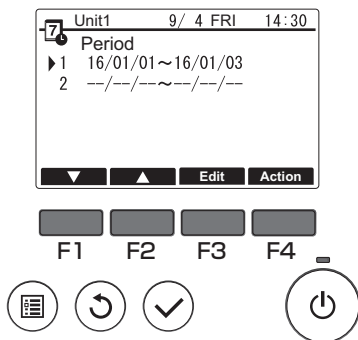

The suitable periods for the period timer will be displayed.

To set the period:

Press the [F1] or [F2] button to select the specified date and then press the [F3] button. ... Move to 3.

To set the operation:

Press the [F1] or [F2] button to select the specified date and then press the [F4] button. ... Move to 4.

3

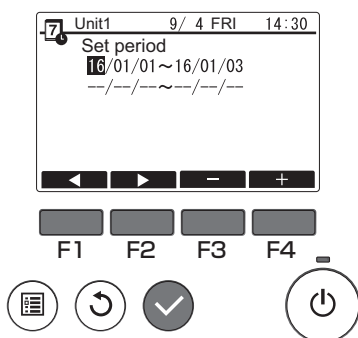

The period setting screen will be displayed.

Press the [F1] or [F2] button to move to the item you want to change.

Press the [F3] or [F4] button to change the start date and end date for the period timer and then press the [Select] button to update the setting.

# 4

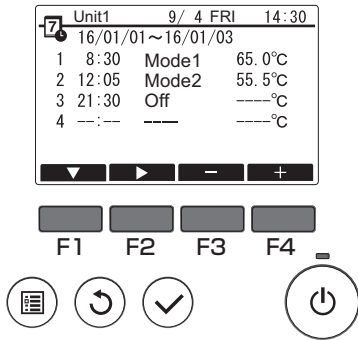

The pattern setting screen will be displayed.

\* Refer to the section on Weekly timer for details on using the pattern setting screen.

Weekly timer operation will be disabled in the following situations:

- When Schedule is disabled

When Schedule is disabled with the centralized controller or the connected unit, Schedule settings cannot be made with the remote controller.

After switching to the desired setting, press the [Select] button. A setting confirmation screen will appear.

**Navigating through the screens**

- To save the settings ..... [Select] button
- To return to the Main display ..... [Menu] button
- To return to the previous screen ..... [Return] button

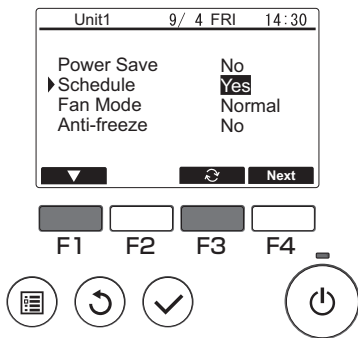

In the Operation setting screen, press the [F1] button to move the cursor to "Schedule".

Press the [F3] button to select "Yes".

## <5> Using Power Save

### Function description

Power Save is a function that regulates the compressor rotation count either daily or according to a specified period and according to a preset time interval or regulated capacity. Use this function when you want to inhibit electric power use. A typical scenario where Power Save can be used to inhibit the power consumption for water heating would be periods of particularly heavy operating loads for air conditioning and other equipment, such as periods when large numbers of people check in at a hotel or similar accommodation facility.

- Approach to power save intervals and time periods  
Specify intervals by using the Day Start Time as the delimiter. Note that this may not match the actual date. Refer to section on "Unit Setting" (Installation Manual) for details.  
You cannot set a time period that spans the Day Start Time.

Example 1) When the Day Start Time is 22:00 on August 1 and 2 and the time period is 22:00 to 08:00  
The shaded (■) periods in the figure below indicate when Power Save is used.

Actual date July 31						Actual date August 1						Actual date August 2						Actual date August 3							
0	4	8	12	16	20	0	4	8	12	16	20	0	4	8	12	16	20	0	4	8	12				
Delimiter based on the Day Start Time						July 31						August 1						August 2				August 3			

Example 2) When the Day Start Time is 12:00 on August 1 and 2 and the time period is 22:00 to 08:00  
The shaded (■) periods in the figure below indicate when Power Save is used.

Actual date July 31						Actual date August 1						Actual date August 2						Actual date August 3							
0	4	8	12	16	20	0	4	8	12	16	20	0	4	8	12	16	20	0	4	8	12				
Delimiter based on the Day Start Time						July 31						August 1						August 2							

**Power Save will not be implemented in the following situations:**

- If a system controller is connected
- While Power Save is disabled

- To use demand control on the connected units, make the settings as shown below.

**(a) To use only connected unit demand control (contact input) without using Power Save on the remote controller**

Button operation

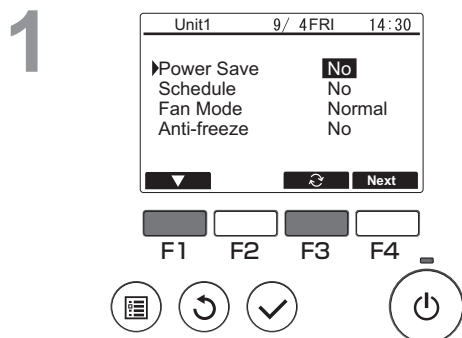

In the Operation setting screen, press the [F1] button to move the cursor to Power Save.

Press the [F3] button to select "No".

- \* Refer to the connected unit Instruction Book for details on connected unit demand control.
- \* Do not set the Power Save settings on the remote controller. Refer to the connected unit Instruction Book for details.

**(b) To use both connected unit demand control (contact input) and Power Save on the remote controller**

- \* Exercise control using low values in the demand control settings and Power Save control capacity. When the contact ON and Power Save start times differ, control will be exercised as of the earliest low value. (See the table below.)

Table: Control values when Power Save and demand control are both used

Period	Power Save value	Connected unit demand control value	Control value actually used
12:00-6:30	– (100%)	– (100%)	100%
6:30-7:00	– (100%)	60%	50%
7:00-11:30	50%	60%	50%
11:30-12:00	50%	– (100%)	50%

→ Because Power Save is set from 7:00, control begins based on the Power Save setting.

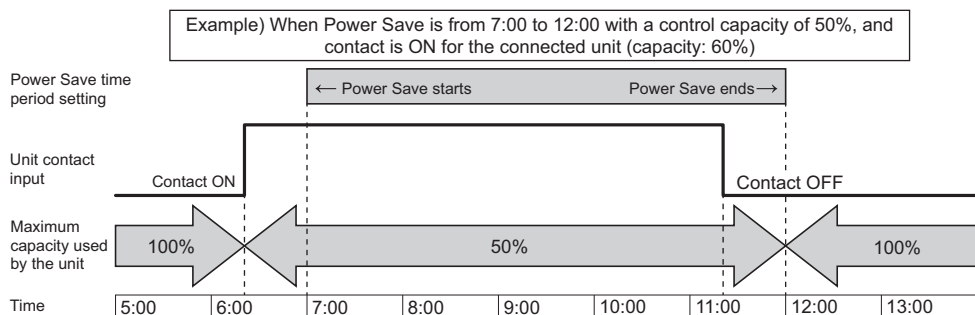

- While the contact is ON or Power Save is being applied, the maximum capacity will be limited to whichever is the lower value of the Power Save and demand control settings.
- While the contact is OFF and Power Save is not applied, control will be exercised with the maximum capacity of 100%.
- The control capacity during periods when Power Save is not set will be 100%.

\* The maximum frequency is restricted depending on the inputs of maximum demand capacity and maximum low-noise capacity as shown below.

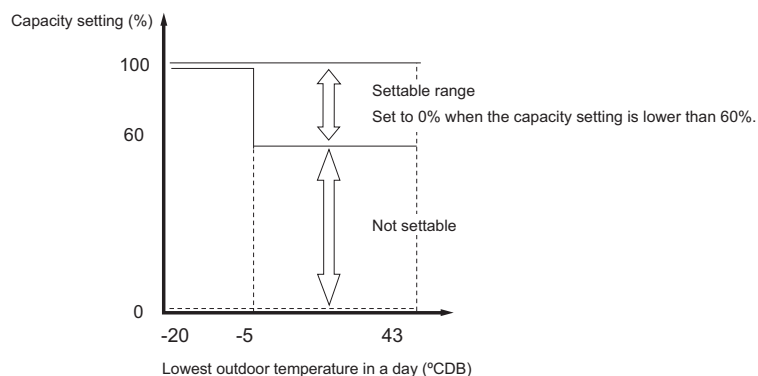

Button operation

**1**

From the Main menu, select "Schedule" > "Power Save" and press the [Select] button.

**2**

Press the [F3] button to proceed to the settings screen.  
You can set 2 types of pattern, as necessary.

\* If the periods specified in 1 and 2 overlap, only period specified in 1 will be implemented.

Press the [F1] to [F4] buttons to set the period and then press the [Select] button.

**3**

The Power Save screen will be displayed.  
Press the [F4] button.

**4**

Press the [F1] to [F4] buttons to set the Power Save start time, end time and control value.



5

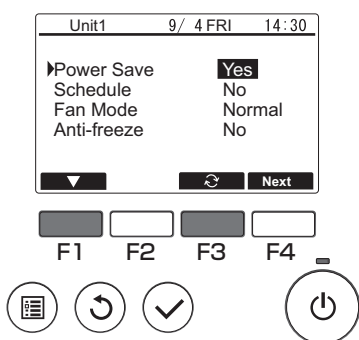

In the Operation setting screen, press the [F1] button to move the cursor to Power Save.  
Press the [F3] button to select "Yes".

## <6> Function setting

### Function description

Sets the functions for each connected unit from the remote controller as required.

- Refer to the Installation Manual for the connected units for details on the connected unit settings at shipment, Function No. and the Data.
- If the function settings change the connected unit functions, all the settings must be managed appropriately, such as by writing them down on paper.

### Button operation

1

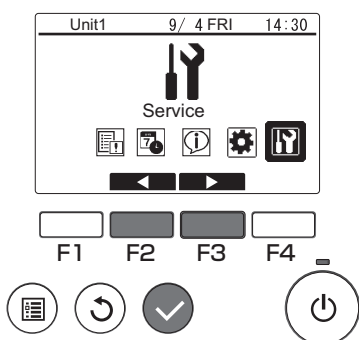

Select "Service" from the Main menu, and press the [Select] button.

2

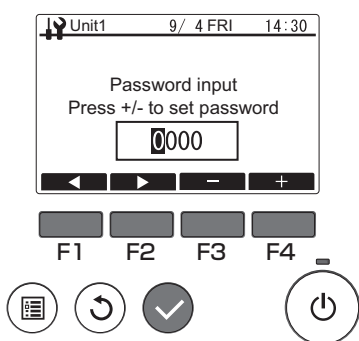

A password input screen will be displayed.  
Enter the current maintenance password (a 4-digit number).  
After entering the 4-digit password, press the [Select] button.  
If the password is correct, the Service menu will be displayed.

3

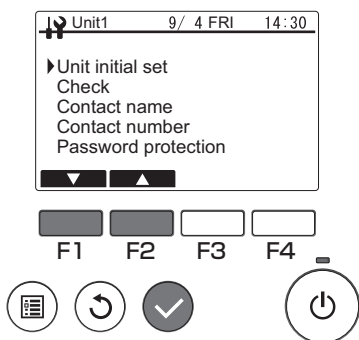

Select "Unit initial set" from the Service menu, and press the [Select] button.

4

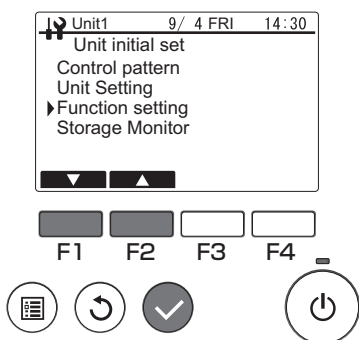

Select "Function setting" from the Unit initial set menu, and press the [Select] button.

5

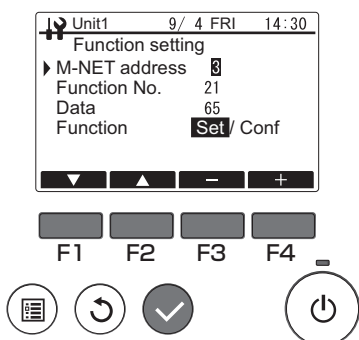

The Function setting screen will be displayed.  
 Press the [F1] or [F2] button to select the connected unit "M-NET address", "Function No." or "Data", and then press the [F3] or [F4] button to change to the desired setting.  
 After changing to the desired setting, press the [Select] button.  
 The setting data transmission screen will be displayed.

To check the current settings, set the "M-NET address" or "Function No." of the connected unit to be checked, select "Conf" in "Function" and press the [Select] button. The screen indicating that the confirmation is being processed will be displayed and the data will be displayed when checking is completed.

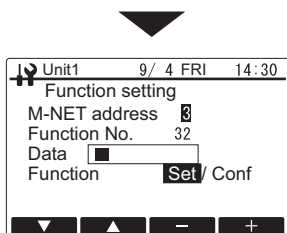

6

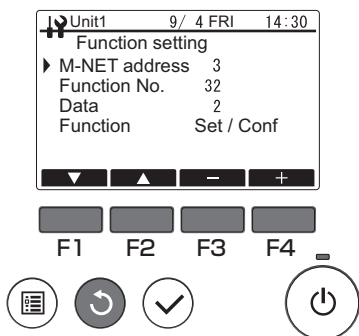

Once data transmission is completed, the screen indicating that the settings have been made will be displayed.  
 To continue making settings, press the [Return] button to return to the screen in procedure 3. Use the same procedure to set other connected unit and Data settings.

**Navigating through the screens**  
 ■ To return to the Service menu ..... [Menu] button  
 ■ To return to the previous screen ..... [Return] button

Function setting	Item
015	Mode 1 differential value (Schedule value)
016	Mode 2 differential value (Schedule value)
017	Mode 3 differential value (Schedule value)
021(*)	Outlet hot water temperature setting

\* When setting the set temperature for Mode 1, Mode 2, or Mode 3 to 65°C or higher, the setting for Function No.21 is required.  
 \* This setting will be used for the secondary side outlet hot water temperature when the secondary side control is enabled.

## <7> Operation status monitoring

### Function description

Check the function information of each unit from the remote controller

#### Button operation

1

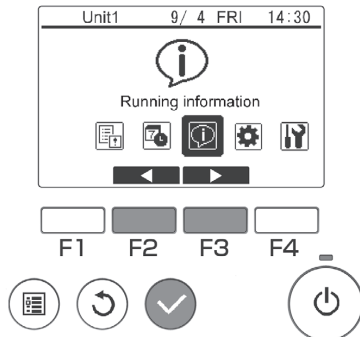

Select "Running information" from the main menu screen, and press the [Select] button.

2

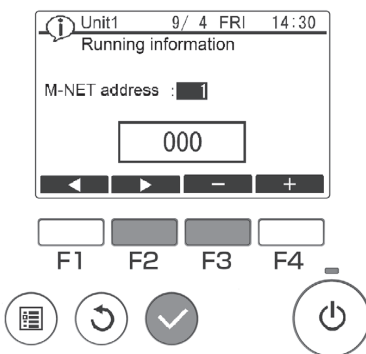

Set the desired M-NET address with the [F2] and [F3] buttons, and press the [Select] button.

3

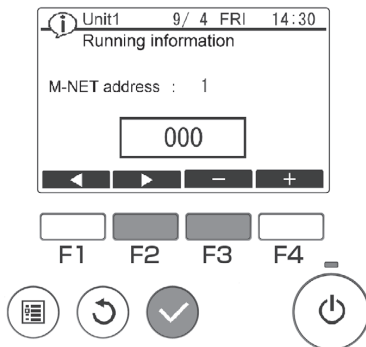

Enter a 3-digit function setting number, and press the [Select] button. The setting information send screen appears.

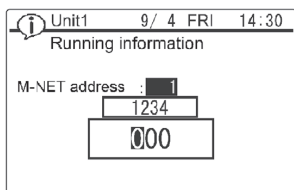
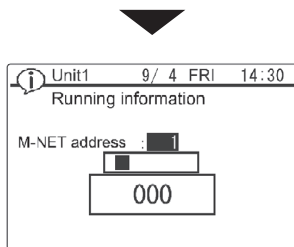

When the information is sent successfully, the function setting values appear in the result display screen.

To continue operation, press the [Return] button to return to the screen of step 2.

Set other M-NET address and function setting number using the same procedure.

#### Navigating through the screens

- To return to the Service menu ..... [Menu] button
- To return to the previous screen ..... [Return] button

Function setting No.

Function setting No.	Description	Remarks
001	High pressure operation data [ $\times 0.1$ MPa]	Data of last hot water storage operation
002	Low pressure operation data [ $\times 0.1$ MPa]	
003	Outlet hot water temperature operation data [ $\times 0.1^\circ\text{C}$ ]	
004	Outdoor air temperature during operation [ $\times 0.1^\circ\text{C}$ ]	
005	Total compressor operation time [ $\times 10$ h]	
006	Outlet hot water temperature [ $\times 0.1^\circ\text{C}$ ]	Current values
007	Inlet water temperature [ $\times 0.1^\circ\text{C}$ ]	
008	High pressure [ $\times 0.1$ MPa]	
009	Low pressure [ $\times 0.1$ MPa]	
010	Discharge refrigerant temperature [ $\times 0.1^\circ\text{C}$ ]	
011	Suction refrigerant temperature [ $\times 0.1^\circ\text{C}$ ]	
012	Operating frequency [ $\times 0.1$ Hz]	
013	Flow velocity sensor [ $\times 0.1$ L/min]	
016	Secondary side outlet water temperature [ $\times 0.1^\circ\text{C}$ ]	
017	Secondary side flow velocity sensor [ $\times 0.1$ L/min]	
018	Secondary side pump output [%]	

Example) No. 001

Remote control display: 38

Actual value: 3.8 MPa



---

## V Electrical Wiring Diagram

[1] Electrical Wiring Diagram.....	73
------------------------------------	----



[1] Electrical Wiring Diagram

QAHV-N560YA-HPB(-BS) ELECTRICAL WIRING DIAGRAM

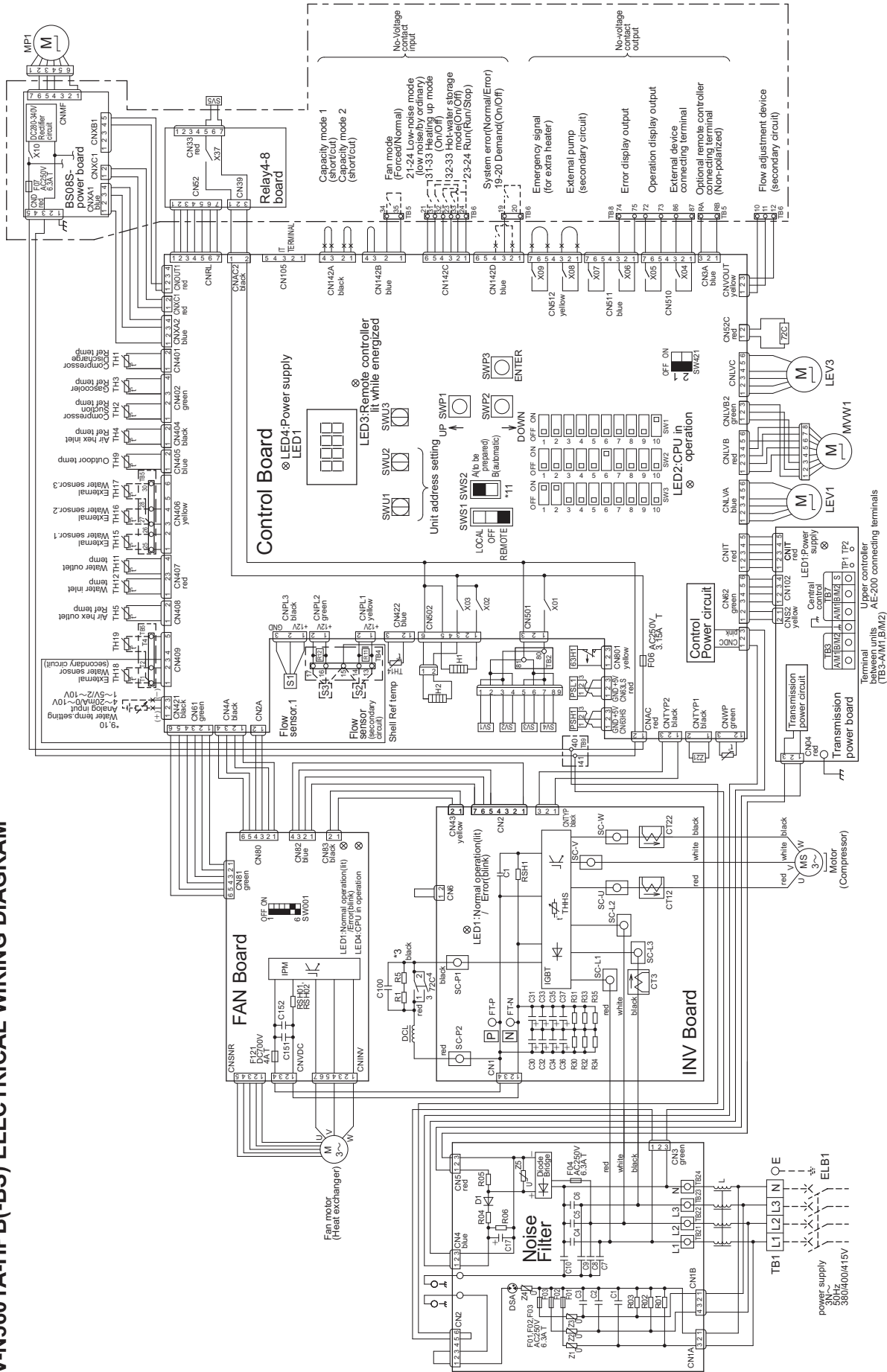

* Capacity mode table	
Max capacity operation	Capacity mode 1 (call)
Energy saving operation 1 (factory setting)	Capacity mode 1, 2 (short)
Energy saving operation 2	Capacity mode 1 (short) Capacity mode 2 (call)



Symbol explanation

Symbol	explanation
CT12	
CT22	Ac current sensor
CT3	
C100	Capacitor (Electrolysis)
DCL	DC reactor
F01	
F02	
F03	
F04	Fuse
F06	
F07	
F121	
H1	Crankcase heater (for heating the compressor)
H2	Electric heater (Antifreeze)
LEV1	Electronic expansion valve (Main circuit)
LEV3	Electronic expansion valve (Injection)
M	Fan motor
MP1	Pump motor
MS	Compressor motor
MVW1	Water flow control valve
PSH1	High pressure sensor
PSL1	Low pressure sensor
R11	Resistance (for Water flow rate sensor 2)
R12	Resistance (for Water flow rate sensor 3)
R1	Electrical resistance
R5	
SV1	Solenoid valve (Defrost)1
SV2	Solenoid valve (Defrost)2
SV3	Solenoid valve (Defrost)3
SV4	Solenoid valve (Defrost)4
SV5	Solenoid valve (Injection circuit)
S1	Water flow rate sensor
THHS	IGBT temperature
TH1 ~5,9,11,12,14	Thermistor
ZZ1	Function setting connector
63H1	High pressure switch
T2C	Electromagnetic relay (Inverter main circuit)
*TH15~18	Thermistor
*S2.3	Water flow rate sensor
<ELB1>	Earth leakage breaker

\* of symbol item is the optional parts, <> is field-supplied parts.

Note

- The broken lines indicate the optional parts, field-supplied parts, and field work.
- Dashed lines indicate sub box
- Faston terminals have a locking function.  
Press the tab in the middle of the terminals to remove them.  
Check that the terminals are securely locked in place after insertion.
- The symbols of the field connection terminals are as follows.  
o: Terminal block x: Connection by cutting the short circuit wire
- The method of input signal of operation can choose one of optimal remote controller or no-voltage input.
- Leave a space of at least 5 cm between the low voltage external wiring (no-voltage contact input and remote controller wiring) and wiring of 100V or greater. Do not place them in the same conduit tube or cable as this will damage the circuit board.
- When cable is used for the control cable wiring, use a separate cable for the following wiring.  
Using the same cable may cause malfunctions and damage to the unit.  
(a) Optional remote controller wiring  
(b) No-voltage contact input wiring  
(c) No-voltage contact output wiring  
(d) Remote water temperature setting
- Use a contact that takes 12VDC 1mA for no-voltage contact input.
- Need to select either Water temperature setting input signal.  
Set the SW421 as shown in the table below.

	SW421-1		SW421-2	
4~20mA	ON	ON	ON	ON
0~10V	OFF	OFF	OFF	OFF
1~5V	OFF	ON	ON	ON
2~10V	OFF	OFF	OFF	OFF

- Use a 4-20mA signal output device with insulation.  
Feeding 30mA or more current may damage the circuit board.
- For prevention of damage of the pump, SWS2 is set in "A"(factory setting).  
Change the slide switch SWS2 [B(automatic)] in Test Run.
- Use a contact that takes 250VAC, 10mA or above, and 1A or below for no-voltage contact output.

When using a local controller, refer to the table below for the types of input/output signals that are available and the operations that correspond to the signals.

**External Input/Output**

Input type	Dry contact		ON (Close)	OFF (Open)	Terminal block/connector
	(a) UNIT OPERATION	Run/Stop	The unit will go into operation when the water temperature drops below the preset temperature.	The unit will stop except when the unit is in the Anti-Freeze mode.	TB6 23-24
(b) FAN MODE	Forced/Normal	The fan will remain in operation after the compressor has stopped (including when the OPERATION status is "STOP").	The fan will stop when the compressor stops.	TB5 34-35	
(c) PEAK-DEMAND CONTROL	On/Off	The unit will operate at or below the maximum capacity level that was set for the Peak-demand control setting.	-	TB6 19-20	
(d) Hot water storage mode	On/Off	Heating operation with the set outlet hot water temperature	Stop	TB6 32-33	
(e) Heating-up mode	On/Off	Heating operation with the maximum water flow amount	Stop	TB6 31-33	
(f) Low-noise mode	On/Off	Operation using the set capacity as an upper limit	Normal operation	TB6 21-24	
<b>Analog</b>				<b>Terminal block/connector</b>	
<b>Input type</b>		<b>Action</b>			
(g) WATER TEMP SETTING CONTROL		Water temperature control can be set by using the external analog input to the CN421 on the circuit board. One analog input type can be selected from the following types: 4-20 mA, 1-5 V, 0-10 V, or 2-10 V.		CN421 2(+)-3(-)	
(h) EXTERNAL WATER SENSOR 1 (optional)		-		TB5 25-26	
(i) EXTERNAL WATER SENSOR 2 (optional)		-		TB5 27-28	
(j) EXTERNAL WATER SENSOR 3		-		TB5 27-30	
(k) EXTERNAL WATER SENSOR (secondary circuit)		-		TB5 T1-T2	
(l) EXTERNAL PUMP (secondary circuit)		-		CN512 1-3	
(m) FLOW SENSOR (secondary circuit)		-		TB4 13-14	
(n) FLOW ADJUSTMENT DEVICE (secondary circuit)		-		TB6 10-12	
Output type	Contact type		Conditions in which the contact closes (turns on)	Conditions in which the contact opens (turns off)	Terminal block/connector
	(o) ERROR INDICATOR	Close/Open	The unit has made an abnormal stop.	During normal operation	TB5 74-75
(p) OPERATION INDICATOR	Close/Open	The "Unit Operation" contact (item (a) above) or the ON/OFF button on the remote controller is ON.	The "Unit Operation" contact (item (a) above) or the ON/OFF button on the remote controller is OFF.	TB5 72-73	
(q) EMERGENCY SIGNAL	Close/Open	Water temperature has dropped below the Booster Heater Operation Water Temperature (TWL1 value) (Item code 1057) and the outside temperature (TAL1 value) (Item code 1058).	Water temperature is at or above "TWL1+2°C" or the outside temperature is at or above "TAL1+2°C".	CN512 1-3	
(r) EXTERNAL DEVICE	Close/Open	During freeze-up protection operation During pump residue operation	Other than the items at left	TB8 86-87	
RC/ SC/ M-NET	REMOTE CONTROLLER	PAR-W31MAA		TB5 RA-RB	
	SYSTEM CONTROLLER	AE-200		TB7 MA-MB*	
	M-NET	-		TB3 MA-MB	

\* When AE-200 is connected, leave the power jumper on the outdoor unit as it is (Connected to CN41 at factory shipment). If the power jumper is connected to CN40, power will excessively be supplied and AE-200 will not properly function.

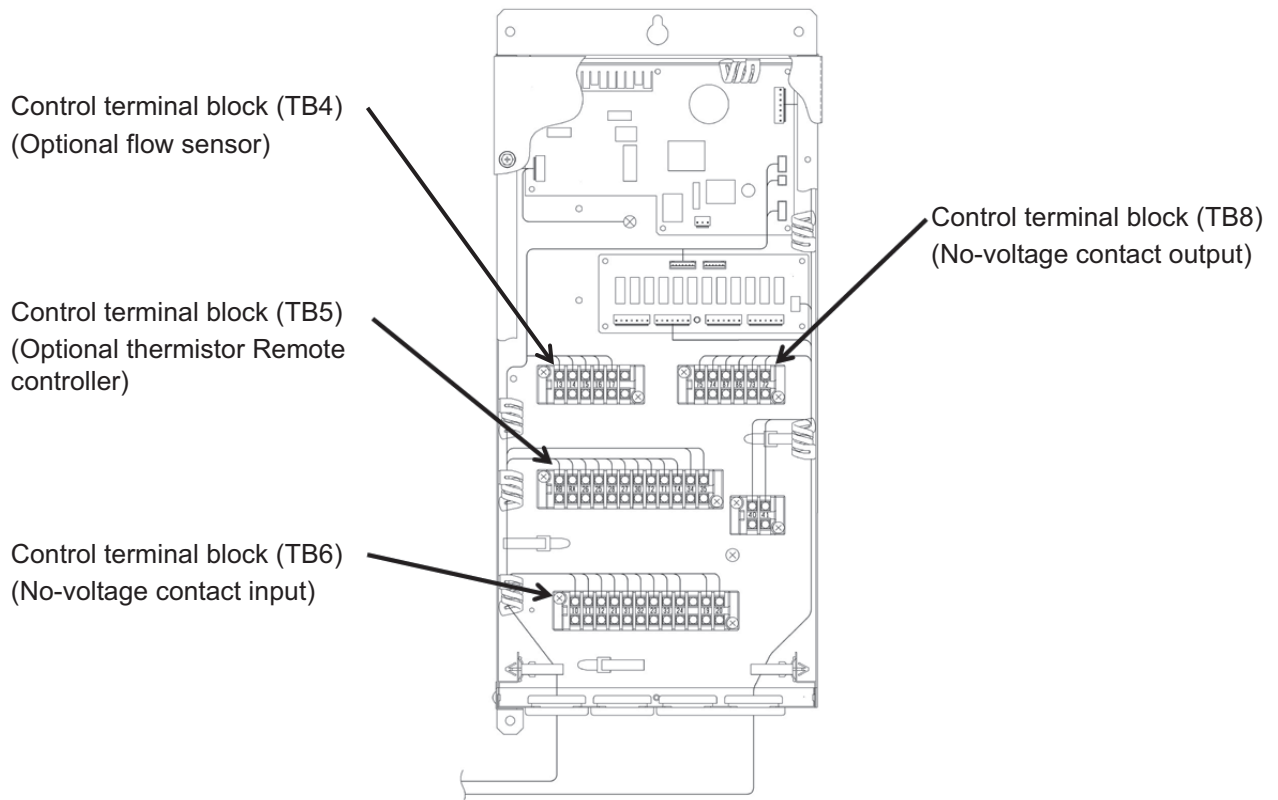

---

## VI Refrigerant Circuit

[1] Refrigerant Circuit Diagram .....	79
[2] Principal Parts and Functions .....	80



**[1] Refrigerant Circuit Diagram**

LEV1	Linear expansion valve1 (MAIN)
LEV3	Linear expansion valve3 (INJ)
PSH1	High-pressure sensor
PSL1	Low-pressure sensor
SV1	solenoid valve1 (defrost)
SV2	solenoid valve2 (defrost)
SV3	solenoid valve3 (defrost)
SV4	solenoid valve4 (defrost)
SV5	solenoid valve5 (Injection)
TH1	Compressor discharge temp sensor
TH2	Compressor suction temp sensor
TH3	heat exchanger outlet refrigerant temp sensor
TH4	Air-side heat exchanger inlet refrigerant temp sensor
TH5	Air-side heat exchanger outlet refrigerant temp sensor
TH9	outside temp sensor
TH11	outlet water temp sensor
TH12	inlet water temp sensor
TH14	Compressor Shell temp sensor
63H1	High-pressure switch
MVW1	water flow control valve
S1	water flow rate sensor

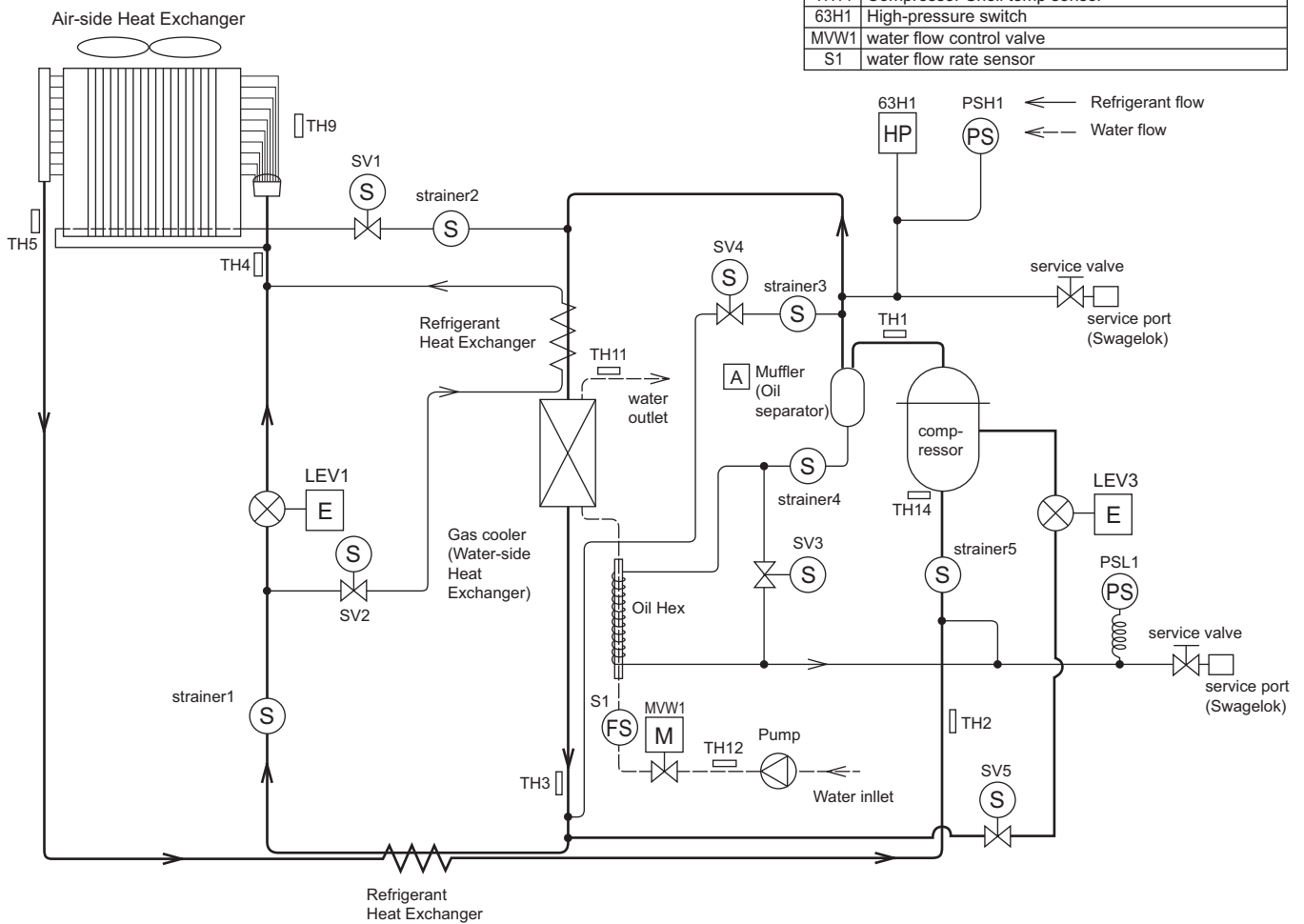

**[2] Principal Parts and Functions**

**Outdoor unit**

Part name	Symbols (functions)	Notes	Usage	Specifications	Check method
Compressor	MS (Comp)		Adjusts the amount of circulating refrigerant by adjusting the operating frequency based on the operating pressure data	Low-pressure shell scroll compressor Wirewound resistance 20°C[68°F] : 0.092 ohm	
High pressure sensor	63HS		1) Detects high pressure 2) Regulates frequency and provides high-pressure protection	<p>63HS Pressure 0~15 MPa Vout 0.5~4.5V 0.026V/0.098 MPa Pressure [MPa] = 3.75 x Vout [V] - 1.875 Pressure = (3.75 x Vout [V] - 1.875) x 145 1 GND (Black) 2 Vout (White) 3 Vcc (DC5V) (Red)</p>	
Low pressure sensor	63LS		1) Detects low pressure 2) Provides low-pressure protection	<p>63LS Pressure 0~10 MPa Vout 0.5~4.5V 0.039V/0.098 MPa Pressure [MPa] = 2.5 x Vout [V] - 1.25 Pressure = (2.5 x Vout [V] - 1.25) x 145 1 GND (Black) 2 Vout (White) 3 Vcc (DC5V) (Red)</p>	
Pressure switch	63H1		1) Detects high pressure 2) Provides high-pressure protection	14.0MPa OFF setting	
Thermistor	TH1 (Discharge)		0°C[32°F] : 698kohm 10°C[50°F] : 413kohm 20°C[68°F] : 250kohm 30°C[86°F] : 160kohm 40°C[104°F] : 104kohm 50°C[122°F] : 70kohm 60°C[140°F] : 48kohm 70°C[158°F] : 34kohm 80°C[176°F] : 24kohm 90°C[194°F] : 17.5kohm 100°C[212°F] : 13.0kohm 110°C[230°F] : 9.8kohm	Degrees Celsius $R_{120} = 7.465k\Omega$ $R_{25/120} = 4057$ $R_t = 7.465 \exp\{4057(\frac{1}{273+t} - \frac{1}{393})\}$	Resistance check

Part name	Symbols (functions)	Notes	Usage	Specifications	Check method
Thermistor	TH2 (Compressor suction)		-	Degrees Celsius $R_0 = 15k\Omega$ $R_{0/80} = 3385$ $R_t = 15 \exp\{3385 (\frac{1}{273+t} - \frac{1}{273})\}$  0°C[32°F] :15kohm 10°C[50°F] :9.7kohm 20°C[68°F] :6.5kohm 25°C[77°F] :5.3kohm 30°C[86°F] :4.4kohm 40°C[104°F] :3.0kohm	Resistance check
	TH3 (Heat Exchanger outlet)		-		
	TH4 (Air-side Heat Exchanger inlet)		-		
	TH5 (Air-side Heat Exchanger outlet)		-		
	TH9 (outdoor temp)		-		
	TH11 (outlet water)		-		
	TH12 (Inlet water)		-		
	TH14 (Compressor shell)		-		
	TH15	External water sensor 1	-		
	TH16	External water sensor 2	-		
	TH17	External water sensor 3	-		
TH18	External water sensor (secondary circuit)	-			
THHS Inverter heat sink temperature		Controls inverter cooling fan based on THHS temperature	Degrees Celsius $R_{50} = 17k\Omega$ $R_{25/120} = 4016$ $R_t = 17 \exp\{4016 (\frac{1}{273+t} - \frac{1}{323})\}$  0°C[32°F] :161kohm 10°C[50°F] :97kohm 20°C[68°F] :60kohm 25°C[77°F] :48kohm 30°C[86°F] :39kohm 40°C[104°F] :25kohm		
Solenoid valve	SV1,2,3,4 defrost control		Controls defrost cycle	AC220 - 240V Open while being powered/ closed while not being powered	Continuity check with a tester
	SV5 INJ control		Turns on/off the injection	AC220 - 240V Open while being powered/ closed while not being powered	
Heater	CH		Heats the refrigerant in the compressor	Cord heater ohm 45W	Resistance check



[ VI Refrigerant Circuit ]

Part name	Symbols (functions)	Notes	Usage	Specifications	Check method
Fan motor	FAN motor		Regulates the heat exchanger capacity by adjusting the operating frequency and operating the propeller fan based on the operating pressure.	AC380V, 920W	
Linear expansion valve	LEV3 (INJ control)		Adjusts the amount of bypass flow from the liquid pipe on the outdoor unit during heating	DC12V Opening of a valve driven by a stepping motor 50-480 pulses (direct driven type)	"Continuity Test with a Tester". Continuity between white, brown, and orange. Continuity between yellow, red, and blue.
	LEV1 (Refrigerant flow adjustment)		Adjusts refrigerant flow during heating	DC12V Opening of a valve driven by a stepping motor 60-480 pulses (direct driven type)	"Continuity Test with a Tester". Continuity between white, brown, and orange. Continuity between yellow, red, and blue.

---

## VII Control

[1] Functions and Factory Settings of the Dip switches .....	85
[2] Operating characteristics and Control Capabilities .....	105



## [1] Functions and Factory Settings of the Dip switches

### 1. Factory Switch Settings (Dip switch settings table)

SW	Function	Usage	Factory setting			Setting timing		
			MAIN circuit	OFF setting	ON setting			
SW1	1	Model setting	Depends on the unit	Leave the setting as it is.		At a reset		
	2							
	3							
	4							
	5							
	6	Test run 1		OFF	-	Operation during test run	Any time	
	7	Not used		OFF	Leave the setting as it is.		At a reset	
	8	Test run 2		OFF	-	Operation during test run	Any time	
	9	Test run 3		OFF	-	Operation during test run		
	10	Model setting		ON	Leave the setting as it is.		At a reset	
SW2	1	Model setting		OFF	Leave the setting as it is.		At a reset	
	2	Model setting		OFF	Leave the setting as it is.		At a reset	
	3	Model setting		OFF	Leave the setting as it is.		At a reset	
	4	Model setting		OFF	Leave the setting as it is.		At a reset	
	5	Freeze-up protection method switching			OFF	Pump operation + heater energization	Compressor operation + heater energization	At a reset
	6	Power supply option to the communication circuit	Switches between supplying or not supplying power to the communication circuit.		ON	Does not supply power to the communication circuit.	Supplies power to the communication circuit.	Any time
	7	Model setting		OFF	Leave the setting as it is.		At a reset	
	8	Model setting		OFF	Leave the setting as it is.		At a reset	
	9	① Individual/Multiple system ② AE connection	① Selects between individual and Multiple system ② Selects AE connection or not		OFF	Individual system	Multiple system or during AE connection	At a reset
	10	Display mode switch 7	This switch is used in combination with dip switches SW3-5 through 3-10 and push switches SWP 1, 2, and 3 to configure or view the settings when performing a test run or changing the system configuration.		OFF	Changes the 7-segment LED display mode.		Any time
SW3	1	Remote reset	Enables or disables the error to be reset from a remote location.		ON	Disables the error to be reset from a remote location.	Enables the error to be reset from a remote location.	At a reset
	2	Auto restart after power failure	Enables or disables the automatic restoration of operation after power failure (in the same mode as the unit was in before a power failure).		ON	An alarm will be issued when power is restored after a power outage. The alarm will be reset when the power is turned off and then turned back on.	Automatically restores operation after power failure.	Any time
	3	Test run 4			OFF	-	Operating during test run	Any time
	4	Function switching (Do not change this setting.)			OFF	Leave the setting as it is.		At a reset
	5	Display mode switch 1	These switches are used in combination with dip switches SW2-5 and push switches SWP 1, 2, and 3 to configure or view the settings when performing a test run or changing the system configuration.		OFF	Changes the 7-segment LED display mode.		Any time
	6	Display mode switch 2			OFF	Changes the 7-segment LED display mode.		Any time
	7	Display mode switch 3			OFF	Changes the 7-segment LED display mode.		Any time
	8	Display mode switch 4			OFF	Changes the 7-segment LED display mode.		Any time
	9	Display mode switch 5			OFF	Changes the 7-segment LED display mode.		Any time
	10	Display mode switch 6			OFF	Changes the 7-segment LED display mode.		Any time

"-" in the table indicates that the function in the corresponding row will be disabled regardless of the actual switch setting.  
 The factory setting for these items is OFF.  
 Refer to page 32 for how to reset errors.

## 2. Slide switch (SWS1) settings

Individual system

SWS1 Setting	Unit Operation
LOCAL	Follows the input signal of the MAIN circuit
OFF	Ignores the signal input
REMOTE	Follows the input signal fed through a dry contact interface

Multiple system (SWS1 in the SUB circuit on both the main and sub units will be ineffective.)

SWS1 Setting		Unit Operation	
Main unit MAIN circuit	Sub unit MAIN circuit	Main unit	Sub unit
LOCAL	LOCAL	Follows the input signal of the Main unit	Follows the input signal of the Sub unit
	OFF		Ignores the signal input
	REMOTE		Follows the input signal of the Sub unit
OFF	LOCAL	Ignores the signal input	Ignores the signal input
	OFF		
	REMOTE		
REMOTE	LOCAL	Follows the input signal fed through a dry contact interface	Follows the input signal of the Main unit
	OFF		Ignores the signal input
	REMOTE		Follows the input signal of the Main unit

Priority order of the water-temperature-setting-input-signal sources

Water temperature can be controlled by using the signals from the four types of input sources listed below. The setting for the item with higher priority will override the settings for the items with lower priorities. The water temperature will be controlled according to the temperature setting in the "Target water temperature" column that corresponds to a specific combination of the settings for the four items.

Priority 1	Priority 2	Priority 3			Target water temperature
Analog input	Main board on the unit	Remote controller PAR-W31MAA Centralized controller AE-200			
	Schedule setting	No remote controller	Manual setting	Schedule setting	
Item code 1073: 2	Ineffective	-	Ineffective	Ineffective	Temperature setting for the analog signal input
Item code 1073: 0	When schedule has been set	-	Ineffective	Ineffective	Selectable from temperature settings Mode1 through Mode3
	When no schedule has been set	When no RC is used	-	-	Target water temp is controlled according to the setting on the PCB (item code 9)
		-	Mode1	-	Mode1
		-	Mode2	-	Mode2
		-	Mode3	-	Mode3
		-	-	When schedule has been set	Target water temp is controlled according to the setting on the remote controller.

\*1 If SW2-8 is set to OFF, water temperature will be controlled by the built-in thermistors TH11~13 and TH16 on the unit.

### 3. Air bleeding operation and flow rate adjustment operation during test run

#### (1) Air bleeding operation

Check there is no water leakage during operation.

For each circuit, perform at least three sets of at least 5 minutes in duration. During the air bleeding operation, use the method below (\*1) to display the water flow rate during operation and check it is stable (no air entrainment).

##### (1)-1. Primary side water circuit air bleeding operation

Step	Contents	Operation and check points	Supplemental explanation						
a	Water level check	Check the water level is not the full level. (Water is supplied even when the target water level has been reached.)	-						
b	Power operation	Turn the power ON.	If the startup operation has not finished, SW2-9 and SW2-3 need to be set as a stopgap measure (see Note 1).						
c	PCB DIP switch setting	Change the setting of SW1-8 from OFF to ON. <table border="1" style="margin-left: auto; margin-right: auto;"> <tr> <td colspan="2" style="text-align: center;">SW1</td> </tr> <tr> <td style="text-align: center;">8</td> <td style="text-align: center;">9</td> </tr> <tr> <td style="text-align: center;">ON</td> <td style="text-align: center;">OFF</td> </tr> </table>	SW1		8	9	ON	OFF	-
SW1									
8	9								
ON	OFF								
d	Operation procedure 2	Change the setting of PCB slide SWS1 from REMOTE to LOCAL. * When the pump sound has become quiet, end operation.	The compressor does not operate. * The pump and motor-operated valve 2 are automatically set to OPEN (starting water flow).						
e	Stop operation 1	Change the setting of PCB DIP SW1-8 from ON to OFF.	* The pump and motor-operated valve 2 are automatically set to CLOSED (ending water flow).						
f	Stop operation 2	Change the setting of PCB slide SWS1 from LOCAL to REMOTE.	-						

##### (1)-2. Secondary side water circuit air bleeding operation

Step	Contents	Operation and check points	Supplemental explanation									
a	Water level check	Check the water level is not the full level. (Water is supplied even when the target water level has been reached.)	-									
b	Power operation	Turn the power ON.	If the startup operation has not finished, SW2-9 and SW2-3 need to be set as a stopgap measure (see Note 1).									
c	Operation procedure 1	Check that the secondary side control is enabled.	For details, refer to page 28 (II-[6]-(3)-3).									
d	PCB DIP switch setting	Change the setting of SW1-8 from OFF to ON. <table border="1" style="margin-left: auto; margin-right: auto;"> <tr> <td colspan="2" style="text-align: center;">SW1</td> <td style="text-align: center;">SW3</td> </tr> <tr> <td style="text-align: center;">8</td> <td style="text-align: center;">9</td> <td style="text-align: center;">3</td> </tr> <tr> <td style="text-align: center;">ON</td> <td style="text-align: center;">OFF</td> <td style="text-align: center;">ON</td> </tr> </table>	SW1		SW3	8	9	3	ON	OFF	ON	-
SW1		SW3										
8	9	3										
ON	OFF	ON										
e	Operation procedure 2	Change the setting of PCB slide SWS1 from REMOTE to LOCAL. * When the pump sound has become quiet, end operation.	The compressor does not operate. * The pump and motor-operated valve 2 are automatically set to OPEN (starting water flow).									
f	Stop operation 1	Change the setting of PCB DIP SW1-8 and SW3-3 from ON to OFF.	* The pump and motor-operated valve 2 are automatically set to CLOSED (ending water flow).									
g	Stop operation 2	Change the setting of PCB slide SWS1 from LOCAL to REMOTE.	-									

(\*1) Water flow rate display method

① Set the PCB DIP switches as shown below.

SW2	SW3					
-10	-5	-6	-7	-8	-9	-10
OFF	OFF	OFF	OFF	OFF	ON	ON

② If the flow rate adjustment operation has never been performed, 'ng' appears on the PCB's digital display after the system startup operation. Press SWP1 (up) or SWP2 (down) to delete the 'ng' from the PCB's digital display (changing the display to a value such as 1).

③ Press SWP3 repeatedly to change the code shown in the PCB's display. The code changes with each press. Continue pressing SWP3 until item code 'C25' is displayed in the PCB's digital display.

④ Once 'C25' is displayed, press SWP1 or SWP2 to display and check the current flow rate. After displaying the flow rate, the display shows the current item code (\*2) if SWP1 to SWP3 are not operated for one minute. Display and check the current flow rate by pressing SWP1 or SWP2 again.

\*2 If the flow rate adjustment operation has never been performed, 'ng' appears in the PCB's digital display after the system startup operation. Press SWP1 or SWP2 to delete the 'ng' from the PCB's digital display (changing the display to 'C25').

(Note 1) As a stopgap measure, change the settings of SW2-9 and SW2-3 as shown in the table below, then restart the power.

	Multiple unit change-over switch SW2-9	Local/internal change-over switch SW2-3
When startup operation has not completed	OFF	ON
When startup operation has completed	-	-

If water shutoff error 2601 occurs during the air bleeding operation, remove the cause of the problem, then change the setting of PCB slide SWS1 from LOCAL to OFF, and back to LOCAL again. The air bleeding operation starts.

(You can clear water shutoff error by turning the power OFF and ON again. The equipment enters standby mode in this case.)

(You can also clear water shutoff errors by changing the setting of PCB DIP SW1-8 or 1-9 from ON to OFF. Turning DIP SW1-8 OFF starts circulation heating circuit air bleeding (manual). Turning DIP SW1-9 OFF starts water supply circuit air bleeding (manual).)



**(2)Water flow rate adjustment operation (When the secondary side control is disabled)**

Step	Contents	Operation and check points	Supplemental explanation
a	Water level check	Check the water level is neither at the full or empty level.	Water is supplied even when the target water level has been reached.
b	Power operation	Turn the power ON.	If the startup operation has not finished, SW2-9 and SW2-3 need to be set as a stopgap measure (see Note 1). If this flow rate adjustment operation has never been performed ‘--ng’ is displayed.
c	Operation procedure	Change the setting of PCB slide SWS1 from REMOTE to LOCAL.	-
d	Operation procedure	Change the setting of SW1-6 from OFF to ON.	* The pump operation and flow rate adjustment valve opening are automatically adjusted, and the flow rate is measured in 30 second intervals. * You can check whether this flow rate adjustment operation has ended or is underway using the setting given in Note 2.
e	Stop operation 1	Change the setting of SW1-6 from ON to OFF.	-
f	Stop operation 2	Change the setting of PCB slide SWS1 from LOCAL to REMOTE.	-

**Checking the flow rate after the flow rate adjustment operation**

The flow rate adjustment operation adjusts the pump output and water flow rate valve opening to determine how to match the flow rate characteristic to the local circuit. **Use the method below (\*3 ① to ④) to check the operation result (characteristic).**

**If air bleeding was not done fully and the map not created properly, a water shutoff error, high pressure error or other problems will occur when operating the system. Check the points below in this case. If the values are abnormal, redo the air bleeding and flow rate adjustment operations.**

(\*3)

① Set the PCB’s DIP switches as shown below.

SW2		SW3				
-10	-5	-6	-7	-8	-9	-10
OFF	OFF	OFF	OFF	OFF	ON	ON

② Press SWP3 repeatedly to change the code shown in the PCB’s display. The code changes with each press (\*4).

Continue pressing SWP3 until ‘dxx’ is displayed in the PCB’s digital display.

(‘dxx’ is a code that stores the flow rate for a given pump output opening and valve opening. See Table 1.)

\*4 If the flow rate adjustment operation has never been performed, ‘ng’ appears after the system startup operation. Perform the flow rate adjustment operation in this case.

③ Press SWP1 or SWP2 to display the operation result (flow rate characteristic) corresponding each flow rate code ‘dxx’ in Table 1 and write them down.

Table 1

	Close <----- Water flow rate adjust valve opening -----> Open									
Pump output opening/water flow rate adjust valve opening	1600	1400	1200	1000	800	600	400	200	100	
Flow rate (pump output opening 16%)	d01	d02	d03	d04	d05	d06	d07	d08	d09	
Flow rate (pump output opening 27%)	d10	d11	d12	d13	d14	d15	d16	d17	d18	
Flow rate (pump output opening 100%)	d19	d20	d21	d22	d23	d24	d25	d26	d27	

<Check result>

	Close <----- Water flow rate adjust valve opening -----> Open									
Pump output opening/water flow rate adjust valve opening	1600	1400	1200	1000	800	600	400	200	100	
Flow rate (pump output opening 16%)										
Flow rate (pump output opening 27%)										
Flow rate (pump output opening 100%)										

④ Check the following.

↓ Check the checkbox.

- All places with flow rate valve opening 1000 through 100 are 2 L/min or above?  
If 2 L/min or below, air may not be bled out. Perform an air bleeding operation and water flow rate adjustment operation again.
- When there are multiple units, the values of the same pump output opening and the same valve opening are not greater or less than those for other units by 10% and 2 L/min or more.  
(In multiple-unit system, perform a water flow rate adjustment operation at the same time.)
- All the values (item codes d01 through d09) are not "0" when the pump output opening is 16%. (Not whole air is bled out.)

(Note 1) Change SW2-9 and SW2-3 as a stopgap procedure as shown in the table below, and then turn the power on.

	Multiple unit change-over switch SW2-9	Local/internal change-over switch SW2-3
When startup operation has not completed	OFF	ON
When startup operation has completed	-	-

(Note 2) The table below shows the water flow rate adjustment operation status in 4 figures when the PCB DIP switch is set as shown in Note 3.

Water flow rate adjustment operation status	Display
Not completed	-- n g
Completed	--- g
In operation	- i n g

(Note 3) PCB DIP switch settings

SW2	SW3					
-10	-5	-6	-7	-8	-9	-10
ON	OFF	OFF	OFF	ON	ON	OFF

**(3)Water flow rate adjustment operation (when the secondary side control is enabled)**

Step	Contents	Operation and check points	Supplemental explanation
a	Water level check	Check the water level is neither at the full or empty level.	Water is supplied even when the target water level has been reached.
b	Power operation	Turn the power ON.	If the startup operation has not finished, SW2-9 and SW2-3 need to be set as a stopgap measure (see Note 1). If this flow rate adjustment operation has never been performed '---ng' is displayed.
c	Operation procedure 1	Check that the secondary side control is enabled.	For details, refer to page 28 (II-[6]-(3)-3).
d	Operation procedure 2	Change the setting of PCB slide SWS1 from REMOTE to LOCAL.	-
e	Operation procedure 3	Change the setting of SW1-6 from OFF to ON.	The pump operation and flow rate adjustment valve opening are automatically adjusted, and the flow rate is measured in 30 second intervals. * You can check whether this flow rate adjustment operation has ended or is underway using the setting given in Note 2.
f	Stop operation 1	Change the setting of SW1-6 from ON to OFF.	-
g	Stop operation 2	Change the setting of PCB slide SWS1 from LOCAL to REMOTE.	-

**Checking the flow rate after the flow rate adjustment operation**

The flow rate adjustment operation adjusts the pump output and water flow rate valve opening to determine how to match the flow rate characteristic to the local circuit. **Use the method below (\*3 ① to ④) to check the operation result (characteristic).**

**If air bleeding was not done fully and the map not created properly, a water shutoff error, high pressure error or other problems will occur when operating the system. Check the points below in this case. If the values are abnormal, redo the air bleeding and flow rate adjustment operations.**

(\*3)

① Set the PCB's DIP switches as shown below.

SW2	SW3					
-10	-5	-6	-7	-8	-9	-10
OFF	OFF	OFF	OFF	OFF	ON	ON

② Press SWP3 repeatedly to change the code shown in the PCB's display. The code changes with each press (\*4).

Continue pressing SWP3 until 'dxx' is displayed in the PCB's digital display.

('dxx' is a code that stores the flow rate for a given pump output opening and valve opening. See Table 1.)

\*4 If the flow rate adjustment operation has never been performed, 'ng' appears after the system startup operation. Perform the flow rate adjustment operation in this case.

③ Press SWP1 or SWP2 to display the operation result (flow rate characteristic) corresponding each flow rate code 'dxx' in Table 1 and write them down.

Table 1  
Primary side circuit flow rate map

	Close <----- Water flow rate adjust valve opening -----> Open								
Pump output opening/water flow rate adjust valve opening	1600	1400	1200	1000	800	600	400	200	100
Flow rate (pump output opening 16%)	d01	d02	d03	d04	d05	d06	d07	d08	d09
Flow rate (pump output opening 27%)	d10	d11	d12	d13	d14	d15	d16	d17	d18
Flow rate (pump output opening 100%)	d19	d20	d21	d22	d23	d24	d25	d26	d27

(Check result)

	Close <----- Water flow rate adjust valve opening -----> Open								
Pump output opening/water flow rate adjust valve opening	1600	1400	1200	1000	800	600	400	200	100
Flow rate (pump output opening 16%)									
Flow rate (pump output opening 27%)									
Flow rate (pump output opening 100%)									

④-1 Check the following. (Primary side circuit)

Primary side circuit

↓ Check the checkbox.

- All places with flow rate valve opening 1000 through 100 are 2 L or above?  
If 2 L/min or below, air may not be bled out. Perform an air bleeding operation and water flow rate adjustment operation again.
- When there are multiple units, the values of the same pump output opening and the same valve opening are not greater or less than those for other units by 10% and 2 L/min or more.  
(In multiple-unit system, perform a water flow rate adjustment operation at the same time.)
- All the values (item codes d01 through d09) are not "0" when the pump output opening is 16%. (Not whole air is bled out.)

Table 2  
Secondary side circuit flow rate map

Pump output value	0	5	10	15	20	25	30	35	40	45	50
Flow rate	d55	d56	d57	d58	d59	d60	d61	d62	d63	d64	d65
Pump output value	55	60	65	70	75	80	85	90	95	100	
Flow rate	d66	d67	d68	d69	d70	d71	d72	d73	d74	d75	

(Check result)

Pump output value	0	5	10	15	20	25	30	35	40	45	50
Flow rate											
Pump output value	55	60	65	70	75	80	85	90	95	100	
Flow rate											

④-2 Check the following. (Secondary side circuit)

↓ Check the checkbox.

- Is the output at 100% (d75) between 20 ℓ/min and 30 ℓ/min?  
If the output is below 20 ℓ/min, water may not flow at a high flow rate during normal operation.  
If the output is above 30 ℓ/min, water may not flow at a low flow rate during normal operation.
  - Take a measure such as adjusting the frequency using an inverter, etc. so that the output at 100% (d75) becomes between 20 ℓ/min and 30 ℓ/min.
- Does a value from 1 ℓ/min to 4 ℓ/min exist for the flow rate at an arbitrary output except 0%?  
If there was no value from 1 ℓ/min to 4 ℓ/min for the flow rate when any output except 0%, the flow rate may not be able to be controlled at a low flow rate.
  - Carry out the air bleeding and flow rate adjustment operations again.
  - Take a measure such as adjusting the frequency using an inverter, etc. so that a value from 1 ℓ/min to 4 ℓ/min exists for the flow rate during output.

(Note 1) Change SW2-9 and SW2-3 as a stopgap procedure as shown in the table below, and then turn the power on.

	Multiple unit change-over switch SW2-9	Local/internal change-over switch SW2-3
When startup operation has not completed	OFF	ON
When startup operation has completed	-	-

(Note 2) The table below shows the water flow rate adjustment operation status in 4 figures when the PCB DIP switch is set as shown in Note 3.

Water flow rate adjustment operation status	Display
Not completed	--ng
Completed	---g
In operation	-ing

(Note 3) PCB DIP switch settings

SW2	SW3					
-10	-5	-6	-7	-8	-9	-10
ON	OFF	OFF	OFF	ON	ON	OFF

## (1) Sensor method settings

### Step 0

Set the ON/OFF switch (SWS1) to OFF.

Set SWS1 to OFF from the remote controller or with the local switch. Settings cannot be changed unless the ON/OFF switch is set to OFF.

### Step 1

Set the dip switches SW2 and SW3.

Set the dip switches on the circuit board as follows before making the settings for the items described in this section.

SW2	SW3					
-10	5	6	7	8	9	10
OFF	OFF	OFF	OFF	ON	OFF	OFF

### Step 2

Select the desired item with the push switch SWP3.

The item codes shown in the table below will appear in order every time the push switch SWP3 is pressed.

Use the push switches SWP1 and SWP2 to change the value of the selected item. The value will keep blinking while it is being changed.

### Step 3

Press the push switches SWP1 (↑) or SWP2 (↓) to increase or decrease the value.

	Item code	Increments	Lower limit	Upper limit	Initial value
Sensor method setting	1214	1	0	2	0

0: Local control method  
 1: Three-sensor method  
 2: Six-sensor method

\* PAR-W31MAA or AE-200 is required when three-sensor or six-sensor method is used.

### Step 4

Press the push switch SWP3 to save the change.

Press SWP3 once within one minute of changing the setting with SWP1 or SWP2 to save the setting.

Once the new setting is saved, the display will stop blinking and stay lit. The display will, then, return to the item code display mode.

If SWP3 is not pressed within one minute, the change will not be saved and the display will return to the item code display mode.

\* When using multiple units, configure the same settings for each unit.

\* When "Local control method" is selected, hot water storage operation ON/OFF control is performed by ON/OFF status of TB6 32-33.

## (2) Three-sensor method or six-sensor method setting

Use the separately sold thermistor (TW-TH16E) to control the water temperature in the storage tank.

### Setting procedures

#### Step 0

Set the ON/OFF switch (SWS1) to OFF.

Set SWS1 to OFF from the remote controller or with the local switch. Settings cannot be changed unless the ON/OFF setting is set to OFF. \*

#### Step 1

Set the dip switches SW2 and SW3.

SW2	SW3					
-10	5	6	7	8	9	10
OFF	OFF	OFF	OFF	ON	OFF	OFF

#### Step 2

Select the desired item with the push switch SWP3.

Item codes 1500 through 1510 relate to sensor method setting. Press the push switch SWP3 to select an item code. Use the push switches SWP1 and SWP2 to change the value of the selected item. The value will keep blinking while it is being changed.

#### Step 3

Press the push switches SWP1 (↑) or SWP2 (↓) to increase or decrease the value.

### Settings table

Items that can be set	Item code	Initial value	Unit	Limits and increments		
				Increments	Lower limit	Upper limit
Mode 1 Thermo-ON thermistor selection	1500	3	-	1	1	3 (6*)
Mode 1 Thermo-OFF thermistor selection	1501	3	-	1	1	3 (6*)
Mode 2 Thermo-ON thermistor selection	1502	1	-	1	1	3 (6*)
Mode 2 Thermo-OFF thermistor selection	1503	2	-	1	1	3 (6*)
Mode 3 Thermo-ON thermistor selection	1504	1	-	1	1	3 (6*)
Mode 3 Thermo-OFF thermistor selection	1505	3	-	1	1	3 (6*)
Number of water control modes	1507	1	-	1	1	3
Mode 1 Thermo differential value	1508	10	°C	1	0	30
Mode 2 Thermo differential value	1509	10	°C	1	0	30
Mode 3 Thermo differential value	1510	10	°C	1	0	30

\* Only for six-sensor method  
Thermistor number 1: TH15, 2: TH16, 3: TH17  
\* Set the item code 1507 to "3" when using all modes (Mode 1, 2, and 3).

#### Step 4

Press the push switch SWP3 to save the change.

Press SWP3 once within one minute of changing the setting with SWP1 or SWP2 to save the setting. Once the new setting is saved, the display will stop blinking and stay lit. The display will, then, return to the item code display mode. If SWP3 is not pressed within one minute, the change will not be saved and the display will return to the item code display mode.

### Usage example

Operation example (Three-sensor method - when a remote controller PAR-W31MAA is used)

Operation mode: Mode 1

Mode 1 Thermo-ON thermistor selection (Item code 1500): 1

Mode 1 Thermo-OFF thermistor selection (Item code 1501): 3

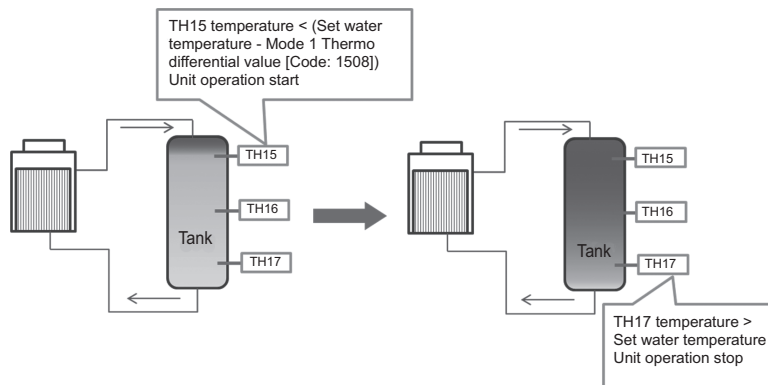

\* Set the operation mode and water temperature from the remote controller PAR-W31MAA.

\* Use the separately sold TW-TH16E temperature thermistor. Two or more units are needed to use the six-sensor method.  
\* Make sure to set the unit outlet hot water temperature.

Referring to the figure below, configure the settings for each unit according to the system.

Three-sensor method		<table border="1"> <thead> <tr> <th rowspan="2">Address</th> <th colspan="4">Item code</th> </tr> <tr> <th>106</th> <th>110</th> <th>111</th> <th>1214</th> </tr> </thead> <tbody> <tr> <td>1</td> <td>3</td> <td>1</td> <td>1</td> <td>1</td> </tr> <tr> <td>2</td> <td>3</td> <td>0</td> <td>1</td> <td>1</td> </tr> <tr> <td>3</td> <td>3</td> <td>0</td> <td>1</td> <td>1</td> </tr> </tbody> </table> <p>* SW2-9: ON (When multiple units are connected)</p>	Address	Item code				106	110	111	1214	1	3	1	1	1	2	3	0	1	1	3	3	0	1	1															
	Address	Item code																																							
106		110	111	1214																																					
1	3	1	1	1																																					
2	3	0	1	1																																					
3	3	0	1	1																																					
		<table border="1"> <thead> <tr> <th rowspan="2">Address</th> <th colspan="6">Item code</th> </tr> <tr> <th>105</th> <th>106</th> <th>107</th> <th>110</th> <th>111</th> <th>1214</th> </tr> </thead> <tbody> <tr> <td>1</td> <td>1</td> <td>3</td> <td>2</td> <td>1</td> <td>1</td> <td>1</td> </tr> <tr> <td>2</td> <td>2</td> <td>3</td> <td>2</td> <td>0</td> <td>1</td> <td>1</td> </tr> <tr> <td>3</td> <td>3</td> <td>3</td> <td>2</td> <td>0</td> <td>1</td> <td>1</td> </tr> </tbody> </table> <p>* SW2-9: ON (When multiple units are connected) * When a remote controller is not connected, the setting for item code [105] is not required.</p>	Address	Item code						105	106	107	110	111	1214	1	1	3	2	1	1	1	2	2	3	2	0	1	1	3	3	3	2	0	1	1					
Address	Item code																																								
	105	106	107	110	111	1214																																			
1	1	3	2	1	1	1																																			
2	2	3	2	0	1	1																																			
3	3	3	2	0	1	1																																			
Six-sensor method		<table border="1"> <thead> <tr> <th rowspan="2">Address</th> <th colspan="5">Item code</th> </tr> <tr> <th>106</th> <th>110</th> <th>111</th> <th>112</th> <th>1214</th> </tr> </thead> <tbody> <tr> <td>1</td> <td>3</td> <td>1</td> <td>1</td> <td>2</td> <td>2</td> </tr> <tr> <td>2</td> <td>3</td> <td>2</td> <td>1</td> <td>-</td> <td>2</td> </tr> <tr> <td>3</td> <td>3</td> <td>0</td> <td>1</td> <td>-</td> <td>2</td> </tr> </tbody> </table> <p>* SW2-9: ON</p>	Address	Item code					106	110	111	112	1214	1	3	1	1	2	2	2	3	2	1	-	2	3	3	0	1	-	2										
	Address	Item code																																							
106		110	111	112	1214																																				
1	3	1	1	2	2																																				
2	3	2	1	-	2																																				
3	3	0	1	-	2																																				
		<table border="1"> <thead> <tr> <th rowspan="2">Address</th> <th colspan="7">Item code</th> </tr> <tr> <th>105</th> <th>106</th> <th>107</th> <th>110</th> <th>111</th> <th>112</th> <th>1214</th> </tr> </thead> <tbody> <tr> <td>1</td> <td>1</td> <td>3</td> <td>2</td> <td>1</td> <td>1</td> <td>2</td> <td>2</td> </tr> <tr> <td>2</td> <td>2</td> <td>3</td> <td>2</td> <td>2</td> <td>1</td> <td>-</td> <td>2</td> </tr> <tr> <td>3</td> <td>3</td> <td>3</td> <td>2</td> <td>0</td> <td>1</td> <td>-</td> <td>2</td> </tr> </tbody> </table> <p>* SW2-9: ON * When a remote controller is not connected, the setting for item code [105] is not required.</p>	Address	Item code							105	106	107	110	111	112	1214	1	1	3	2	1	1	2	2	2	2	3	2	2	1	-	2	3	3	3	2	0	1	-	2
Address	Item code																																								
	105	106	107	110	111	112	1214																																		
1	1	3	2	1	1	2	2																																		
2	2	3	2	2	1	-	2																																		
3	3	3	2	0	1	-	2																																		

\* For how to make item code settings, refer to page 95.



### (3) Setting the outlet hot water temperature

① Selecting the outlet hot water temperature setting method

Select one of the following three outlet hot water temperature setting methods.

#### Setting procedures

**Step 0**  
Set the ON/OFF switch (SWS1) to OFF.

Set SWS1 to OFF from the remote controller or with the local switch. Settings cannot be changed unless the ON/OFF setting is set to OFF. \*

**Step 1**  
Set the dip switches SW2 and SW3.

Set the dip switches on the circuit board as follows before making the settings for the items described in this section.

SW2	SW3					
-10	5	6	7	8	9	10
OFF	OFF	OFF	OFF	OFF	ON	OFF

**Step 2**  
Select the desired item with the push switch SWP3.

Press the push switch SWP3 to select item code 2. Press the push switches SWP1 or SWP2 to change the value of the selected item. The value will keep blinking while it is being changed.

**Step 3**  
Press the push switches SWP1 (↑) or SWP2 (↓) to increase or decrease the value.

#### Settings table

Items that can be set	Item code	Initial value	Unit	Setting			Setting change from an optional remote controller
				Increments	Lower limit	Upper limit	
Setting method selection	1073	0	-	1	0	2	Not possible

0: Outlet Hot Water Temp. input PCB or PAR-W31MAA or AE-200  
1: Outlet Hot Water Temp. input IT terminal  
2: Outlet Hot Water Temp. input 4-20 mA (Analog input)

**Step 4**  
Press the push switch SWP3 to save the change.

Press SWP3 once within one minute of changing the setting with SWP1 or SWP2 to save the setting. Once the new setting is saved, the display will stop blinking and stay lit. The display will, then, return to the item code display mode. If SWP3 is not pressed within one minute, the change will not be saved and the display will return to the item code display mode.

\* Configure the settings for all units even when controlling multiple units.

② Outlet hot water temperature setting method from PCB

**Setting procedures**

**Step 0**  
Set the ON/OFF switch (SWS1) to OFF.

Set SWS1 to OFF from the remote controller or with the local switch. Settings cannot be changed unless the ON/OFF setting is set to OFF. \*

**Step 1**  
Set the dip switches SW2 and SW3.

Set the dip switches on the circuit board as follows before making the settings for the items described in this section.

SW2	SW3					
-10	5	6	7	8	9	10
OFF	OFF	OFF	OFF	OFF	ON	OFF

**Step 2**  
Select the desired item with the push switch SWP3.

Press the push switch SWP3 to select item code 2. Press the push switches SWP1 or SWP2 to change the value of the selected item. The value will keep blinking while it is being changed.

**Step 3**  
Press the push switches SWP1 (↑) or SWP2 (↓) to increase or decrease the value.

**Settings table**

Items that can be set	Item code	Initial value	Unit	Setting			Setting change from an optional remote controller
				Increments	Lower limit	Upper limit	
Outlet Hot Water Temp. setting	9	65	°C	0.5	40	*90 (80)	Possible

\* This becomes the secondary side outlet hot water temperature when the secondary side control is enabled.

\* Secondary control disabled: 90°C, Secondary control enabled: 80°C

**Step 4**  
Press the push switch SWP3 to save the change.

Press SWP3 once within one minute of changing the setting with SWP1 or SWP2 to save the setting. Once the new setting is saved, the display will stop blinking and stay lit. The display will, then, return to the item code display mode. If SWP3 is not pressed within one minute, the change will not be saved and the display will return to the item code display mode.

③ Settings from PAR-W31MAA

Refer to page 66.

#### (4) Scheduled operation

Configure the schedule settings using a remote controller (PAR-W31MAA) or a system controller (AE-200).

#### (5) Peak-demand control operation

Peak-demand control is a function used to control the power consumptions of the units during peak-demand hours.

**The number of units in operation and the compressor's maximum operating frequency will be controlled according to the peak-demand control signal.**

Individual system control	Multiple system control
Individual unit control Maximum frequency = Maximum capacity under peak-demand control	Depending on the peak-demand control setting that is made on the main unit, the number of units in operation and the maximum operating frequency of the units in operation will be adjusted.

#### Setting procedures

Set the maximum capacity setting on the circuit board.

##### Step 0

Set the ON/OFF switch (SWS1) to OFF.

Set SWS1 to OFF from the remote controller or with the local switch.  
Settings cannot be changed unless the ON/OFF setting is set to OFF. \*

##### Step 1

Set the dip switches SW2 and SW3.

Set the dip switches on the circuit board as follows before making the settings for the items described in this section.

SW2	SW3					
-10	5	6	7	8	9	10
OFF	OFF	OFF	OFF	OFF	ON	OFF

##### Step 2

Select the desired item with the push switch SWP3.

Press the push switch SWP3 to select item code 2.  
Press the push switches SWP1 or SWP2 to change the value of the selected item.  
The value will keep blinking while it is being changed.

##### Step 3

Press the push switches SWP1 (↑) or SWP2 (↓) to increase or decrease the value.

#### Settings table

Items that can be set	Item code	Initial value	Unit	Setting			Setting change from an optional remote controller
				Increments	Lower limit	Upper limit	
Maximum capacity setting	2	100	%	5%	0	100	Not possible
Peak-demand control start time	3	13:00	Hour: minute	1	0000	2359	Not possible
Peak-demand control end time	4	16:00	Hour: minute	1	0000	2359	Not possible

##### Step 4

Press the push switch SWP3 to save the change.

Press SWP3 once within one minute of changing the setting with SWP1 or SWP2 to save the setting.  
Once the new setting is saved, the display will stop blinking and stay lit. The display will, then, return to the item code display mode.  
If SWP3 is not pressed within one minute, the change will not be saved and the display will return to the item code display mode.  
(\* ) If the peak-demand control contact is ON, units will operate at the maximum capacity that was set in the steps above.

\* The maximum frequency may be restricted depending on the inputs of maximum demand capacity and maximum low-noise capacity. Refer to page 64 for details.

## (6) Setting the total number of units for a multiple system

### Step 0

Set the ON/OFF switch (SWS1) to OFF.

Set SWS1 to OFF from the remote controller or with the local switch. Settings cannot be changed unless the ON/OFF switch is set to OFF.

### Step 1

Set the dip switches SW2 and SW3.

Set the dip switches on the circuit board as follows to select how external inputs are received.

SW2	SW3					
-10	5	6	7	8	9	10
OFF	OFF	OFF	OFF	ON	ON	ON

### Step 2

Select the desired item with the push switch SWP3.

The item codes shown in the table below will appear in order every time the push switch SWP3 is pressed.

Use the push switches SWP1 and SWP2 to change the value of the selected item. The value will keep blinking while it is being changed.

### Step 3

Press the push switches SWP1 (↑) or SWP2 (↓) to increase or decrease the value.

#### Setting table

	Item code	Increments	Lower limit	Upper limit	Initial value
Unit address	105	1	1	8	2
Total number of units in the system*1	106	1	0	16	1
AE-200 connection	107	2	0	2	0
Own unit role*2	110	1	0	2	0
Main sensor address	111	1	1	50	1
Sub sensor address*3	112	1	1	51	51
Secondary circuit control*4	121	1	0	1	0

\*1 Enter the total number of units including the main unit. Applicable only to the main unit.

\*2 0: Sub unit

1: Main sensor

2: Sub sensor (For six-sensor method)

\*3 Set the address of the sub sensor for six-sensor method.

\*4 0: Secondary side control disabled

1: Secondary side control enabled

### Step 4

Press the push switch SWP3 to save the change.

Press SWP3 once within one minute of changing the setting with SWP1 or SWP2 to save the setting.

Once the new setting is saved, the display will stop blinking and stay lit. The display will, then, return to the item code display mode.

If SWP3 is not pressed within one minute, the change will not be saved and the display will return to the item code display mode.

### Step 5

Turn the power back on. Reset the system.

After changing the settings, re-initialize the system according to the procedures detailed on page 32.

**Note** The new setting will not be saved unless a reset is performed.

### Setting the unit addresses

Refer to "(4) System configuration procedures : Multiple system" (page 29).

**(7) Selecting the item that normally appears on the LED**

SW2	SW3						Display content
	-10	5	6	7	8	9	
OFF	OFF	OFF	ON	OFF	OFF	OFF	Displays the operation mode.(*1)
OFF	OFF	ON	ON	OFF	OFF	OFF	Displays the operation mode.(*2)
OFF	ON	ON	OFF	OFF	OFF	OFF	Displays the current water temperature.
OFF	ON	OFF	OFF	OFF	OFF	OFF	Displays the water-temperature setting.
OFF	OFF	OFF	OFF	OFF	OFF	OFF	Displays the high and low refrigerant pressures.

(\*1)

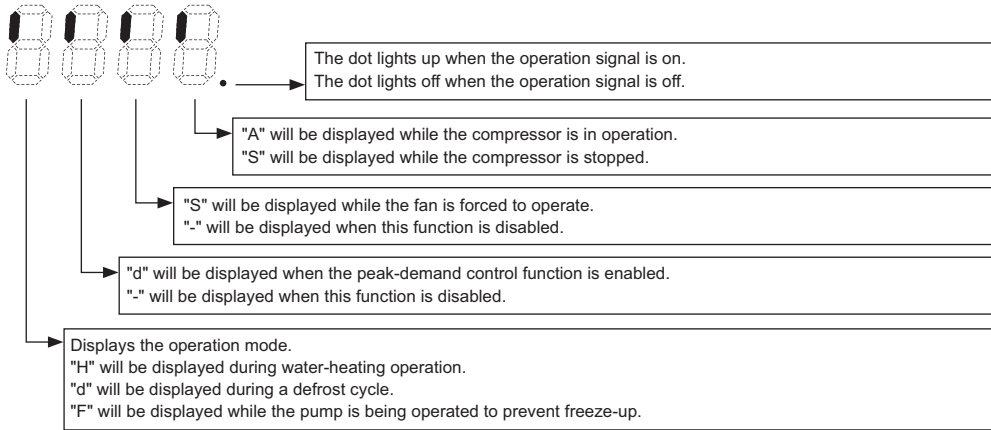

(\*2)

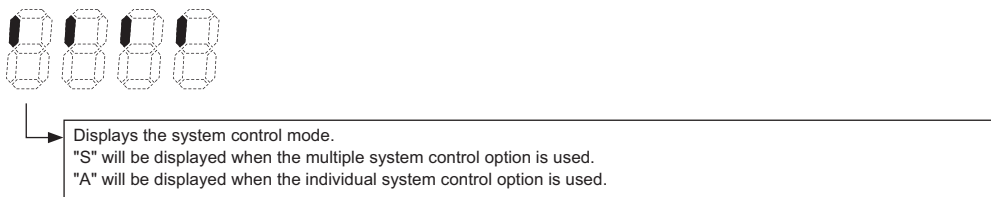

**(8) Settings using Analog input**

**Remote water temperature setting input signal type**

Analog input type can be selected from the following four types:

- "0": 4-20 mA
- "1": 0-10 V
- "2": 1-5 V
- "3": 2-10 V

Select item code 1075 to set the type of analog input signal to be used to set the water temperature from a remote location.

Setting procedures

Set the dip switches on the circuit board as follows to change the settings.

Step 1  
Set dip switches SW2, SW3, SW421-1, and SW421-2.

	SW421-1	SW421-2
4-20 mA	ON	ON
0-10 V	OFF	OFF
1-5 V	OFF	ON
2-10 V	OFF	OFF

	SW2	SW3					
	-10	5	6	7	8	9	10
Switch settings	OFF	OFF	OFF	OFF	OFF	ON	OFF

Step 2  
Select the item to be set with push switch SWP3.

Select the type of analog input signal to be used to set the water temperature from a remote location.

Step 3  
Change the values with push switches SWP1 (↑) or SWP2 (↓).

Press push switch SWP3 to select the item code.

Change the values with push switches SWP1 and SWP2.

Until the changed values are saved, the values will blink.

Items that can be set	Item code	Initial value	Unit	Setting			Note	Setting change from an optional remote controller
				Increments	Lower limit	Upper limit		
Water temperature setting input signal type	1075	0		1	0	3		Not possible

Step 4  
Press push switch SWP3 to save the changed value.

Press SWP3 once within one minute of changing the settings to save the change.

When the new setting is saved, the display will stop blinking and stay lit. The display will, then, return to the item code display mode.

If SWP3 is not pressed within one minute, the change will not be saved, and the display will return to the item code display mode.

## Setting the water temperature using analog signal input

### Select the analog input format

- When the water temperature setting input signal type is set to 0 (4-20 mA)
  - External analog input signal of between 5.9 and 18.3 mA: the preset temperature will be linearly interpolated.

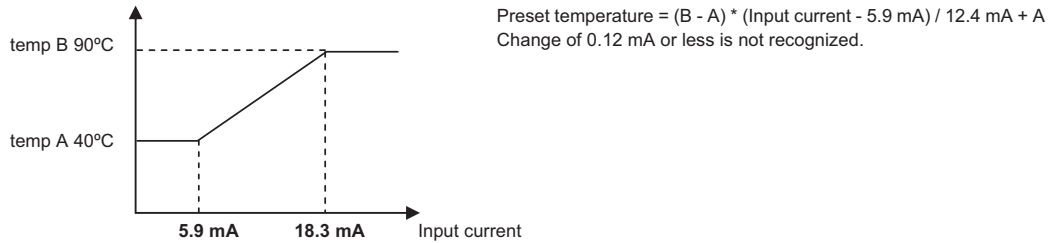

- When the water temperature setting input signal type is set to 1 (0-10 V)
  - External analog input signal of between 1.0 and 9.1 V: the preset temperature will be linearly interpolated.

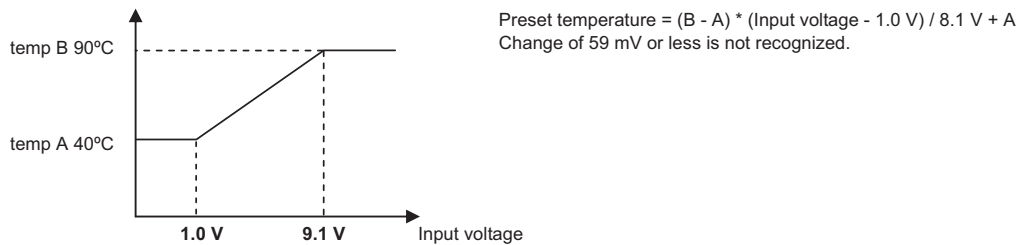

- When the water temperature setting input signal type is set to 2 (1-5 V)
  - External analog input signal of between 1.5 and 4.5 V: the preset temperature will be linearly interpolated.

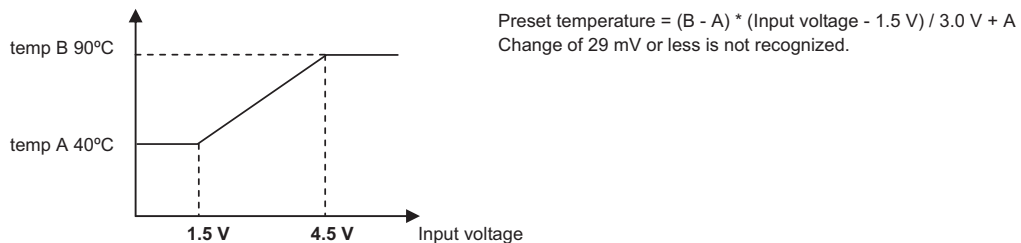

- When the water temperature setting input signal type is set to 3 (2-10 V)
  - External analog input signal of between 2.9 and 9.1 V: the preset temperature will be linearly interpolated.

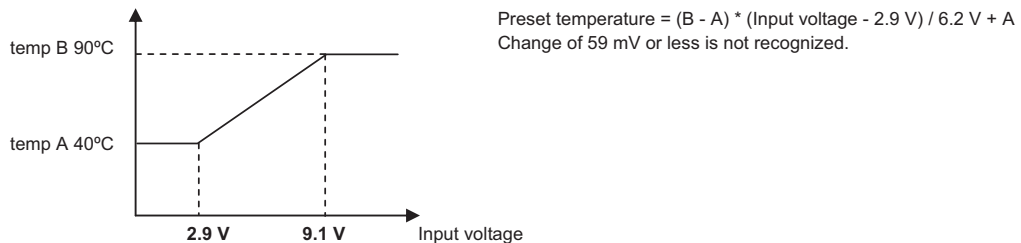

## [2] Operating characteristics and Control Capabilities

### -1- Operating characteristics

Function	Component		Symbol	Control/ Detection		Action	Unit	Trigger condition	
Unit protection	Pressure switch	High-pressure switch	63H1	HP	63H1	ON	MPa	(10.0)	
						OFF	MPa	14.0 $^{+0}_{-1.0}$	
		High-pressure sensor	63HS	HP	63HS	OFF	MPa	-	
		Low-pressure sensor	63LS	LP	63LS	OFF	MPa	♦The low pressure has dropped below 1.0 MPa within 120 seconds of compressor start-up.	
	Compressor overcurrent relay			Compressor current		OFF	A	33	
	Built-in thermistor on the fan motor (Stops the motor)			Built-in thermistor on the fan motor		ON	°C	90±15	
						OFF	°C	145±5	
	Thermistor	Discharge refrigerant temp. (Discharge temp. override protection)		TH1	Discharge gas temp.		OFF	°C	♦A discharge gas temperature of 130°C or above has been detected for 30 seconds while the compressor is in operation. (Preliminary abnormal stop) If this happens three times, the unit will make an abnormal stop. ♦If a discharge gas temperature of 135°C or above was detected, the unit will make an abnormal stop.
		Air-side HEX inlet temp. (vacuum protection)		TH4	Air-side HEX inlet temp.		OFF	°C	A heat-side heat exchanger inlet temperature of -14°C or (0.78 x TH9 -16)°C or less was detected.
		Compressor shell temp. (compressor floodback protection)		TH14	Comp. shell temp.		OFF	°C	A shell bottom SH temperature of 10°C or below has been detected for 40 minutes while the compressor is in operation.
Inverter heatsink temp		THHS	INV. heat-sink temp.		OFF	°C	A temperature of 80°C or above has been detected for 10 minutes or a temperature of 90°C or above was detected.		
Refrigerant circuit control	Liquid injection circuit		LEV3 SV5	Discharge gas temp.			°C	Injection is controlled by referencing the high pressure.	
Pump control	Inlet (freeze-up protection) Outlet (freeze-up protection)	TH12 TH11	Water inlet or Water outlet	ON	°C	3			
				OFF	°C	5			
	Outside temperature thermistor (freeze-up protection)	TH9	Outside temp.	ON	°C	1			
				OFF	°C	3			
Freeze-up protection circuit							The pump turns on when the water inlet temperature has reached below the "ON" threshold AND the outside temperature has reached below the "ON" threshold when the compressor is stopped.		



**-2- Initial control**

- When the power is turned on, the initial processing of the microcomputer is given top priority.
- During the initial processing, processing of the operation signal is suspended and is resumed after the initial processing is completed.  
(Initial processing involves data processing by the microcomputer and initial setup of the LEV opening. This process takes up to two minutes.)
- During the initial processing " 9999 " will appear on the LED monitor on the MAIN board.

**-3- Compressor frequency**

- The maximum frequency will be determined based on the relationship between the water temperature and the outside temperature as well as the ON/OFF status of the Energy-save/Maximum capacity contact.  
(The values not on listed in the table are interpolated.)

**-4- Defrost start/end conditions**

**Defrost start conditions**

Defrost begins when conditions 1) through 3) listed below are all met.

- 1) Refrigerant temperature at the air heat exchanger inlet is at or below the value determined in relation to the outdoor temperature(\*2).
- 2) Cumulative compressor operation time has reached 35 minutes since the completion of the last defrost operation.
- 3) Cumulative compressor operation time has reached 35 minutes since the operation-ON signal was sent. Or the outdoor temperature is -15°C or below and the compressor shell bottom SH temperature is at or below the specified temperature.

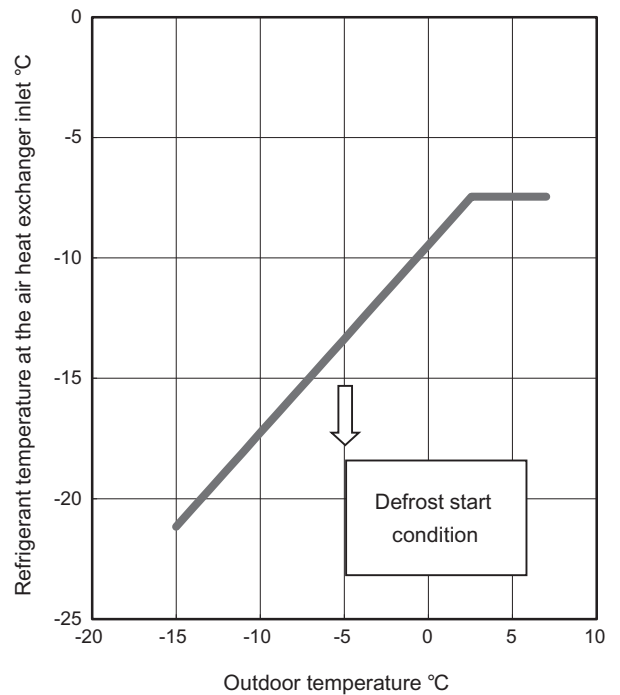

**Defrost end conditions**

Defrost ends when any of the conditions 1) through 4) listed below is met.

- 1) Maximum defrost time (15 minimum) has been reached. Maximum defrost time is 20% of the cumulative compressor operation time from the last defrost or from the time operation-ON signal was sent.
- 2) Three minutes have elapsed since the refrigerant temperature at the air heat exchanger outlet reached 4°C or above.
- 3) Low pressure has reached 8.5 MPa or above.
- 4) High pressure has reached 12.0 MPa or above at the frequency of 30 Hz.

**-5- Outdoor unit fan**

The fan's rotation speed will be controlled to approximate the values in the table below that are obtained based on the outside temperature and the low pressure.  
(Pressures and temperatures will be monitored, and the fan frequency will change accordingly in three steps.)

Fan rotation speed (rpm)	Outdoor temp.(A) (°C)	Fan rotation speed (rpm)	Outdoor temp.(A) (°C)
230	39 < A	498	18 < A ≤ 21
258	36 < A ≤ 39	540	12 < A ≤ 18
291	33 < A ≤ 36	600	10 < A ≤ 12
328	30 < A ≤ 33	650	5 < A ≤ 10
371	27 < A ≤ 30	750	3 < A ≤ 5
413	24 < A ≤ 27	800	- 3 < A ≤ 3
455	21 < A ≤ 24	830	A ≤ - 3

**-6- Injection LEV**

**Operating range of the LEV**

Opening range: 50-480 (fully open)

LEV operation speed

- Open 30.7 pulse/sec
- Close 30.7 pulse/sec

**At startup**

- For five minutes after startup, the valve will be fixed to Initial Setting.

**During operation**

- After five minutes have elapsed after startup, LEV2 (Injection LEV) opening will be regulated at 60-second intervals to bring the high pressure to the target pressure.

**-7- LEV in the main circuit**

**Operating range of the LEV**

The opening range of the LEV is between 60 and 480 (fully open).

LEV operation speed

- Open 30.7 pulse/sec
- Close 30.7 pulse/sec

**At startup**

- For one minute and thirty seconds after startup, the valve will be fixed to the Initial Setting.

**During operation**

- Ninety or more seconds after startup, the LEV opening will be controlled every 30 seconds according to the changes in compressor frequency, pressure, and temperature.
- The LEV will be controlled to keep the shell bottom SH in the range between 15 and 25K.

**-8- Operation during power failure**

Duration of power failure		20 ms or shorter	20 ~ 200ms	200 ms or longer
Detection of power failure		Undetectable	Instantaneous power failure	Detection of power failure
Operation during power failure		Normal operation	During an instantaneous power failure, the unit will be controlled according to the input status of the circuit board immediately before the instantaneous power failure.	All outputs will be turned off immediately after power failure.
Operation after power is restored	Automatic restoration after power failure is set to "Enabled" (SW3-2 is set to ON.)	Normal operation	The circuit board will start receiving input.	The unit will be controlled according to the input status of the circuit board immediately before the power failure, except that the input status of the dry contact after the power is restored will override the one before the power failure. For three minutes after the power is restored, the unit will not operate.
	Automatic restoration after power failure is set to "Disabled" (SW3-2 is set to OFF.)			The unit will stop, displaying the error code for power failure. The error will be cleared when the operation command signal is off.

**-9- Preventing short-cycling**

Operation and stoppage of compressor is controlled under the following restrictions to prevent frequent start-stops of compressor.

- 1) Compressor will not restart for three minutes from the last stoppage (three-minute restart delay).
- 2) Compressor will not restart for 10 minutes from the last startup.
- 3) The maximum allowable number of compressor startup times will be 36 times in a given day. Compressor will not restart for the amount of time calculated based on the remaining allowable number of startup times within the number of hours left in a given day. (See the formula below.\*)

\* The maximum allowable number of compressor startup times is set to 36 times per day to prevent short-cycling with 22:00 being set as the beginning of the day by default. 24 hours times 60 minutes divided by 36 times will yield 40 minutes, which will be the maximum restart-delay time. The restart-delay time is calculated based on the hours left in a given day and on the remaining allowable number of compressor startup times. For example, if the compressor has already gone into operation four times by 10 o'clock in the morning, the restart delay time will be 22 minutes and 30 seconds based on the following calculation  $(24-12) \times \text{hours} \times 60 \text{ minutes} / (36-4) = 22 \text{ minutes and } 30 \text{ seconds}$ . The minimum restart-delay time is set to 10 minutes. \*\*"Number of hours in a day (24 hours)" minus "number of hours that elapsed from 22:00 the previous day until 10 am (=12 hours)"

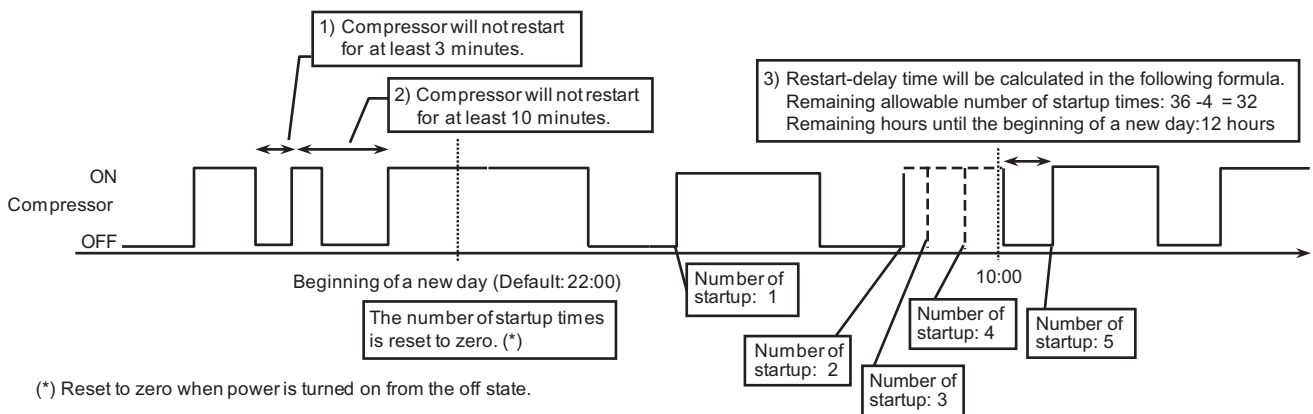

### -10- Peak-demand control

General idea about demand control in the system with a combination of a heat pump and a combustion-type hot water boiler.  
 →During peak-demand hours, the operation of the air conditioning units is given higher priority than that of the heat pump units.

The peak-demand control function is a function that restricts the maximum capacity of the units. The maximum operation capacities of the units are restricted to specific levels relative to the maximum capacity of the units (= the compressors are operating at the maximum rotation speed (100 Hz on the unit described in this manual)) being set as 100%.

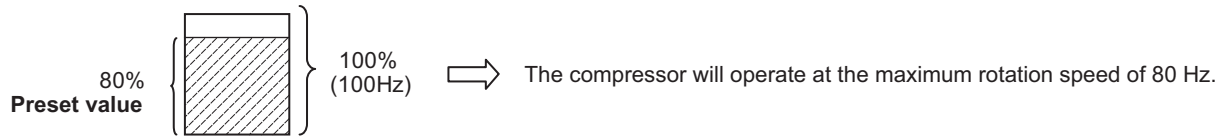

### -11- Multiple system control

#### 1. Electrical wiring diagram

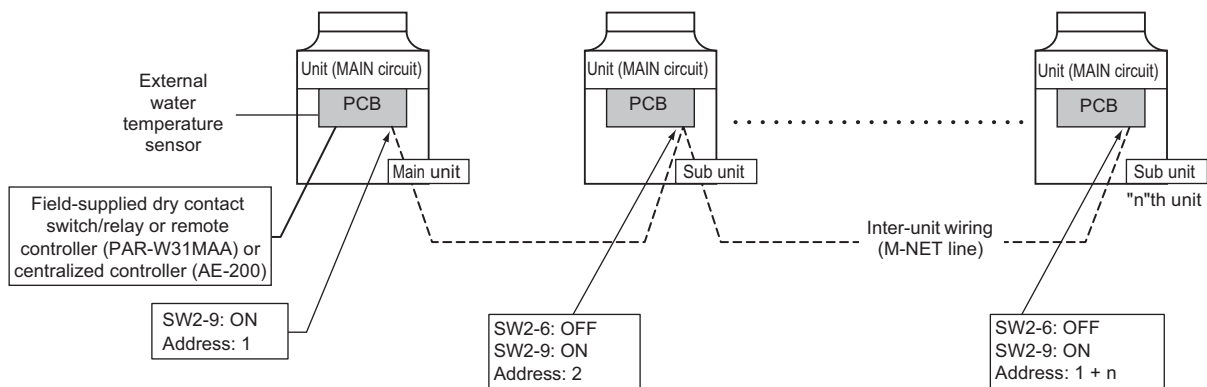

\* The main unit is the unit to which an external water temperature sensor is connected.

(\*) Main/Sub units and switch settings

	SW2-9 ( Multiple system)
Main unit (Unit to which the external water temperature sensor is connected.)	ON

### -12- Automatic operation of pump for freeze-up protection

#### 1. Natural freeze-up protection

Control method		Natural freeze-up protection based on both the outside temperature and the water temperature
Details	Pump start conditions	"Outside temperature is within $\pm 1\text{ }^{\circ}\text{C}$ of $1\text{ }^{\circ}\text{C}$ " OR "Inlet or outlet water temperature is within $\pm 1\text{ }^{\circ}\text{C}$ of $3\text{ }^{\circ}\text{C}$ "
	Pump stop conditions	"Outside temperature is more than $\pm 1\text{ }^{\circ}\text{C}$ of $3\text{ }^{\circ}\text{C}$ " OR "Inlet or outlet water temperature is more than $\pm 1\text{ }^{\circ}\text{C}$ of $5\text{ }^{\circ}\text{C}$ "

### -13- System control method

#### ① Local control method

Dry contact input of operation and operation mode commands from the local controller is used to start or end the water heating/hot water storage operation.

When the operation commands to heat water and store hot water are both received at the same time, the command to heat water overrides.

#### ② Three-sensor method

Three water temperature sensors are installed on the hot water storage tank. Water heating operation is started or ended according to the preset water temperature.

When a dry contact input is received from the local controller, the unit will be operated in the hot water storage operation except when it is already operated in the water heating mode.

\* PAR-W31MAA or AE-200 is required when three-sensor method is used.

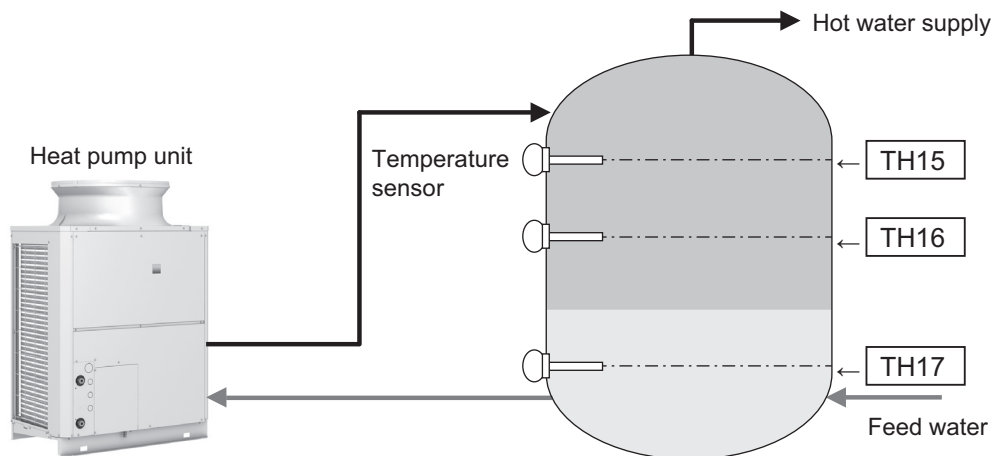

### Control logic of Storage Tank Temperature

Use the optional parts thermistor (TW-TH16E) to control the water temperature in the storage tank.

Ex. Mode setting = Mode2

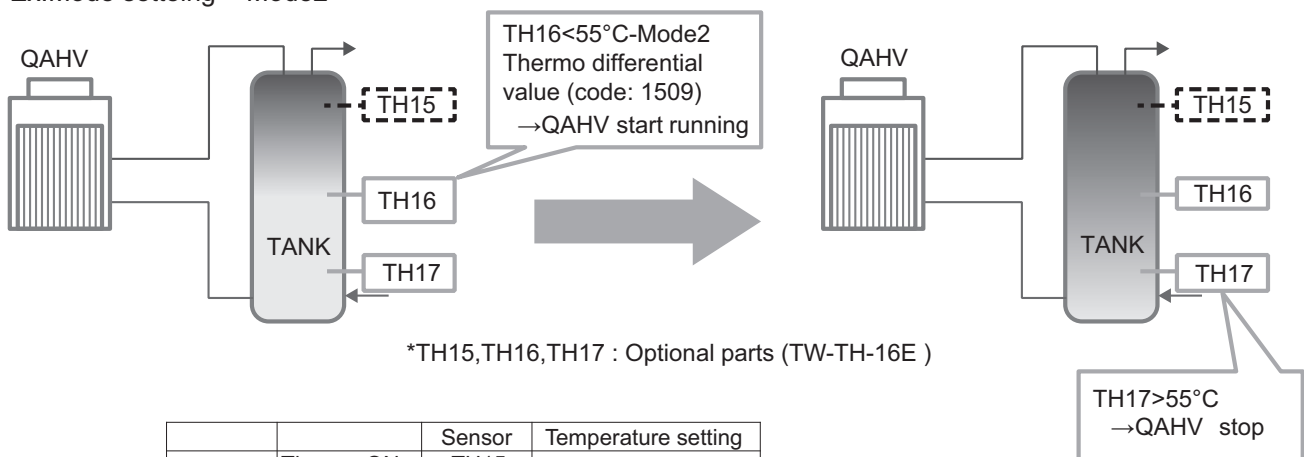

		Sensor	Temperature setting
Mode1	Thermo-ON	TH15	65°C
	Thermo-OFF	TH16	
Mode2	Thermo-ON	TH16	55°C
	Thermo-OFF	TH17	
Mode3	Thermo-ON	TH15	60°C
	Thermo-OFF	TH17	

↑                      ↑  
Setting adjustable

Hot water storage operation is started or stopped based on the readings of six water temperature sensors that are installed to the water storage tank. The use of six sensors requires at least two units. When a dry contact input is received from the local controller, the unit will be operated in the hot water storage operation except when it is already operated in the water heating mode.

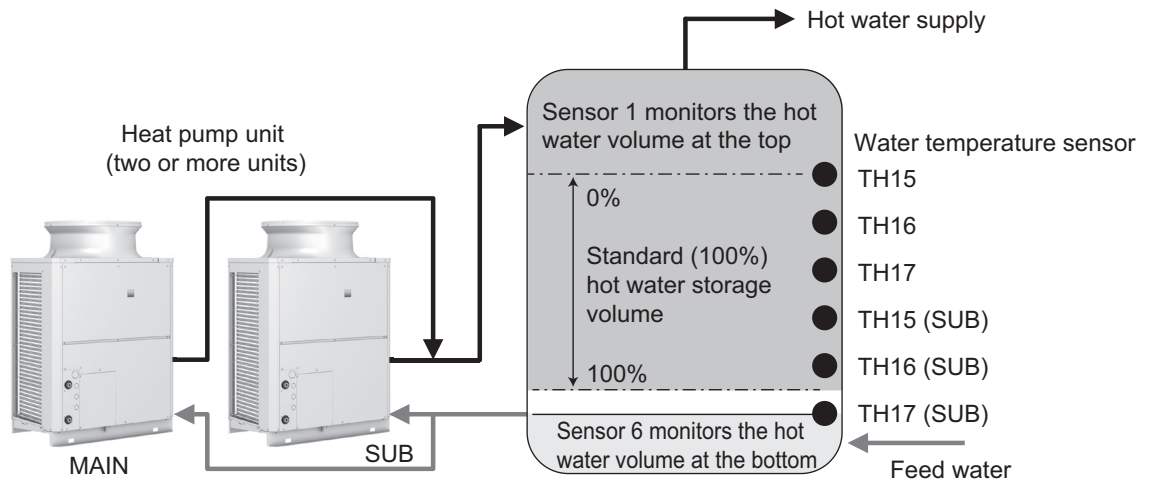

\* The use of six-sensor monitoring requires the installation of at least two units. When using only one unit for industrial use, three sensors will be used.

\*Use a water pressure sensor TW-TH-16E.

#### -14- Remote water temperature setting input signal type

By setting item code 1075, external analog signals can be used to set the water temperatures.

Analog input type can be selected from the following four types:

- "0": 4-20 mA
- "1": 0-10 V
- "2": 1-5 V
- "3": 2-10 V

**External water temperature sensor TW-TH16E**

**1. Parts that are required to install an external water temperature sensor**

- (1) External water temperature sensor
  - (2) Wiring to connect the sensor and the unit\*
  - (3) Wiring terminals to connect the wiring to the sensor and the terminal block on the unit  
(Four for M4 screws)\*
- \*Items (1) and (2) are field supplied.

Wire specifications

Wire size	2-core cable Min. 1.25 mm <sup>2</sup>
Type	CVVS or CPEVS
Maximum length	20 m

**2. Installing the external water temperature sensor**

- Install the external water temperature sensor where the water pipes merge or on the load-side tank as shown in the figure at right.
- Install horizontally or vertically on top of the pipe.
- When installing horizontally, make sure the wire faces down.

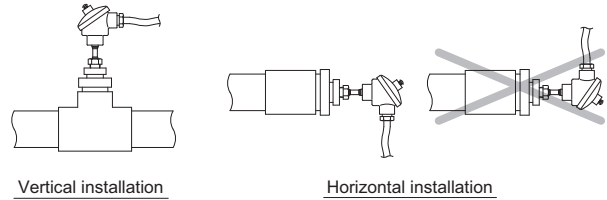

**3. Wiring the external water temperature sensor**

Connect the external temperature sensor wiring to the terminal block in the control box on the unit as shown in the figure below.

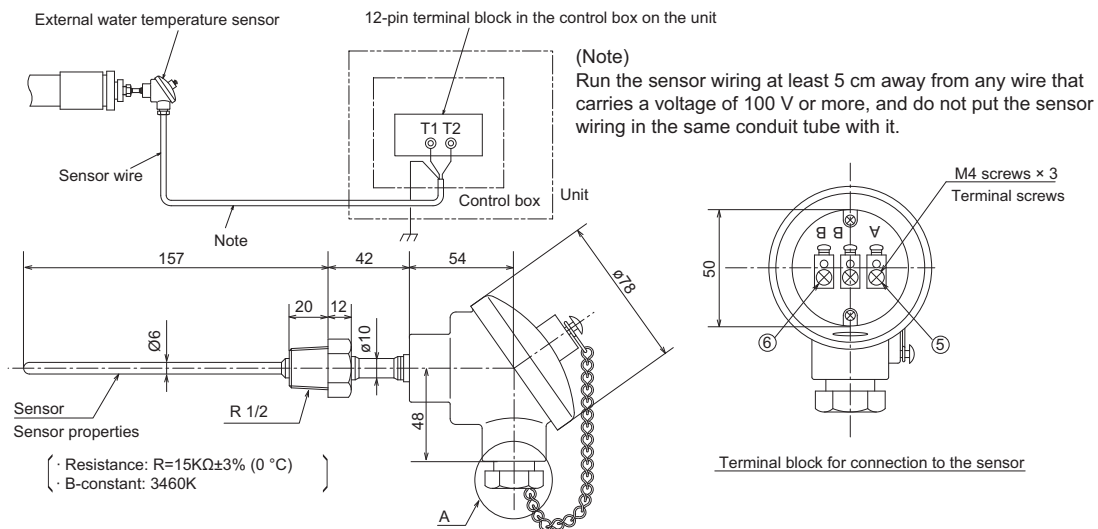

Connect the sensor wiring to terminals T1 and T2 of the 12-pin terminal block in the control box on the unit.

Connect the shield to the earth terminal.

Thread the wire to the external water temperature sensor through parts ② through ④ as shown in the figure at right. Attach M4 terminals (field-supplied) to the wires, and connect them to ⑤ and ⑥ (terminals A and B).

Cut the shield wire. Do not connect it to the terminal. (Connect the shield on the unit side to the ground terminal.)

After the wire is connected, securely tighten the tightening screw ④, and then caulk the gap between the wire ① and the tightening screw to keep water from entering.

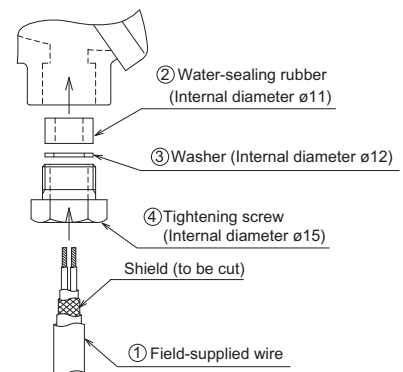

Detailed view of the area labeled "A" in the figure above

---

## VIII Test Run Mode

[1] Items to be checked before a Test Run .....	115
[2] Operating the Unit.....	117
[3] Refrigerant .....	118
[4] Standard operating characteristics (Reference data) .....	118





## [1] Items to be checked before a Test Run

(1) Check for refrigerant leak and loose cables and connectors.

(2) Measure the insulation resistance between the power supply terminal block and the ground with a 500V megger and make sure it reads at least 1.0Mohm.

**Note**

- Do not operate the unit if the insulation resistance is below 1.0Mohm.
- Do not apply megger voltage to the terminal block for transmission line. Doing so will damage the controller board.
- Never measure the insulation resistance of the transmission terminal block for the RA, RB, MA, MB(TB3). Do not attempt to measure the insulation resistance of TB7.
- The insulation resistance between the power supply terminal block and the ground could go down to close to 1Mohm immediately after installation or when the power is kept off for an extended period of time because of the accumulation of refrigerant in the compressor.
- If insulation resistance reads at least 1Mohm, by turning on the main power and powering the belt heater for at least 12 hours, the refrigerant in the compressor will evaporate and the insulation resistance will go up.
- Do not measure the insulation resistance of the terminal block for transmission line for the unit remote controller.

**Note**

Securely tighten the cap.

(3) Check the phase order of the 3-phase power source and the voltage between each phase.

**Note**

Open phase or reverse phase causes the emergency stop of test run. (4102 error)

(4) When a power supply unit is connected to the transmission line for centralized control, perform a test run with the power supply unit being energized.

(5) Pre-energize the compressor.

- A. A case heater is attached to the bottom of the compressor to prevent the refrigerant oil from foaming when starting up. Switch on the power to the case heater and keep it turned on for **at least 12 hours** before starting a test run. (Compression of liquid refrigerant that may happen if the unit is started up without pre-energizing the compressor may damage the valve or cause other problems. When foaming is happening, the compressor will make cracking sounds for a few seconds at the beginning of operation.)
- B. Supply water to the water circuit before operating the pump. Operating the pump without water may damage the shaft seal.

(6) Check the pressure.

Translate the pressure readings into saturating temperatures, and make sure these values fall into the ranges specified in the table below.

Outdoor temperature	DB - 7 °C / WB - 6 °C	DB 7 °C / WB 6 °C	DB 16 °C / WB 12 °C
Incoming water temperature	5 °C	9 °C	17 °C
Supply hot water temperature	65 °C	65 °C	65 °C
High pressure [MPa]	12.0	9.5	10.0
Low pressure [MPa]	2.0	3.2	3.7

(7) Check that the correct voltage is applied.

Check that the voltage that is applied while the unit is stopped and the load-side voltage of the solenoid contactor in the relay box during operation are within the voltage ranges. Check the voltage in all phases (L1, L2, and L3), and make sure that the voltage imbalance between the phases is 2% or less.

(8) Check either the power supply current or the compressor current.

Check the compressor current in all phases (L1, L2, and L3).

(9) Check for short-cycling of discharge air.

Check that the intake air temperature is not unusually higher or lower than the outside temperature. During operation, the difference between the heat exchanger inlet temperature and outside temperature should be 1 °C or less.

**(10) Check that the unit is operating properly according to the temperature adjustment function.**

When a pull-down operation is completed, check that the hot water temperature adjustment function will come on and that the unit will automatically go on and off. Make sure the ON/OFF cycle (beginning of an operation until the next) is at least 10 minutes. (The unit features an anti-short-cycling protection.)

**Notes on temperature adjustment function**

The water temperature can be controlled based on the inlet or the outlet temperature sensor reading. Select one to use. Refer to "VII [1]1.Factory Switch Settings (Dip switch settings table)" (page 85) and "(3)Setting the outlet hot water temperature" (page 98) for how to select the water temperature control method and how to set the water temperature.

Do not disconnect the power wire to the compressor in an attempt to keep the compressor from going into operation during test run. (If it is done, the control board will not sense that the compressor is stopped, and the water temperature will not be controlled properly and the unit may come to an abnormal stop.)

## **[2] Operating the Unit**

---

### **1. Initial Operation**

- (1) Make sure the Run/Stop switch that controls the unit on the local control panel is switched off.
- (2) Switch on the main power.
- (3) Leave the main power switched on for at least 12 hours before turning on the Run/Stop switch that controls the unit on the on-site control panel to warm up the compressor.  
(The compressor will not be warmed up if initial settings have not been made. Make sure to make initial settings.)
- (4) Switch on the Run/Stop switch that controls the unit on the on-site control panel.

### **2. Daily Operation**

#### **To start an operation**

Switch on the Run/Stop switch that controls the unit on the local control panel, or press the ON/OFF button on the remote controller. (\*1)

#### **Note**

The unit described in this manual features a circuit that protects the compressor from short-cycling. Once the compressor stops, it will not start up again for up to 10 minutes. If the unit does not start when the ON/OFF switch is turned on, leave the switch turned on for 10 minutes. The unit will automatically start up within 10 minutes.

#### **To stop an operation**

Switch off the Run/Stop switch that controls the unit on the on-site control panel, or press the ON/OFF button on the remote controller. (\*1)

Refer to the following pages for how to use the remote controller.

### **IMPORTANT**

- Keep the main power turned on throughout the operating season, in which the unit is stopped for three days or shorter (e.g., during the night and on weekends).
- Unless in areas where the outside temperature drops to freezing, switch off the main power when the unit will not be operated for four days or longer. (Switch off the water circulating pump if the pump is connected to a separate circuit.)
- When resuming operation after the main power has been turned off for a full day or longer, follow the steps under "Initial Operation" above.
- If the main power was turned off for six days or longer, make sure that the clock on the unit is correct.

### **3. Operating the unit from the control board on the unit.**

- (1) To start the unit  
Set the switch SWS1 on the circuit board to "LOCAL."
- (2) To stop the unit  
Set the switch SWS1 on the circuit board to "OFF."

**[3] Refrigerant**

Unit type	QAHV-N560YA-HPB
Refrigerant type	R744
Refrigerant charge	6.5kg

**[4] Standard operating characteristics (Reference data)**

## Reference data

	Operating condition	Unit	①	②
Ambient temperature	DB	°C	7	16
	WB	°C	6	12.4
Temperature	Discharge refrigerant	°C	90	92
	Suction refrigerant	°C	7	8
	Shell temperature	°C	18	20
	Air-side heat exchanger inlet	°C	2	6
	Outside temperature	°C	7	16
	Inlet water temperature	°C	9	17
	Outlet water temperature	°C	65	65
Pressure	High pressure	MPa	9.5	10
	Low pressure	MPa	3.2	3.7
LEV opening	Main circuit	pulse	170	180
	Injection	pulse	60	60
Compressor	Frequency	Hz	78	73
Fan	Frequency	rpm	650	540

---

## IX Troubleshooting

[1] Maintenance items.....	121
[2] Troubleshooting .....	126
[3] Troubleshooting Principal Parts .....	136
[4] Refrigerant Leak .....	152
[5] Parts Replacement Procedures .....	153
[6] Removing scale from the gas cooler.....	159



## [1] Maintenance items

### 1. Checking the error history

Take the following steps to view the last six error histories (error codes).

**Note**

Refer to "[2] 2.Diagnosing Problems Using Error Codes" for information about error codes. (page 129)

#### Setting procedure

**Step 1**

Set the dip switches SW2 and SW3.

Set the dip switches on the circuit board as follows to view error histories.

SW2	SW3					
10	5	6	7	8	9	10
OFF	OFF	OFF	OFF	OFF	ON	ON

**Step 2**

Select the desired item with the push switch SWP3.

Press the push switch SWP3 to toggle through the item codes listed below. Select an item code from 1 through 18, and press either of the push switches SWP1 or SWP2 to display the error history (error code) in blinking form.

**Step 3**

Press the push switches SWP1 (↑) or SWP2 (↓) to increase or decrease the value.

Refer to "Error history item list" on the next page for the types of errors that appear on error history.

**Step 4**

Press the push switch SWP3 to save the change.

Press SWP3 to stop the blinking and return to the item code display.



**Error history item list**

Item	Item code	LED display	Notes
Error history 1	1	Error Code	(Note1) (Note2) (Note3)
Error history 1 details (Inverter error)	2	Error Code	
Error history 1/Occurrence time	3	Time	
Error history 2	4	Error Code	
Error history 2 details (Inverter error)	5	Error Code	
Error history 2/Occurrence time	6	Time	
Error history 3	7	Error Code	
Error history 3 details (Inverter error)	8	Error Code	
Error history 3/Occurrence time	9	Time	
Error history 4	10	Error Code	
Error history 4 details (Inverter error)	11	Error Code	
Error history 4/Occurrence time	12	Time	
Error history 5	13	Error Code	
Error history 5 details (Inverter error)	14	Error Code	
Error history 5/Occurrence time	15	Time	
Error history 6	16	Error Code	
Error history 6 details (Inverter error)	17	Error Code	
Error history 6/Occurrence time	18	Time	
Current inlet water temperature Twi	c01	First decimal place	(Note4)
Current outlet water temperature Two	c02	First decimal place	
Outdoor temperature Ta	c03	First decimal place	
TH15 water temperature (unit)	c04	First decimal place	
Refrigerant suction temperature	c05	First decimal place	
Refrigerant discharge temperature	c06	First decimal place	
Refrigerant temperature at gas cooler outlet	c07	First decimal place	
Refrigerant temperature at air heat exchanger inlet	c08	First decimal place	
Refrigerant temperature at air heat exchanger outlet	c09	First decimal place	
LEV opening	c10	Integer	
High pressure	c12	Second decimal place	
Low pressure	c13	Second decimal place	
Compressor frequency	c14	Integer	
SH (target superheat)	c15	First decimal place	
SH (actual superheat)	c16	First decimal place	
Inverter pump opening	c17	First decimal place	
Valve opening (pulse)	c18	Integer	
Heatsink temperature (THHS)	c19	First decimal place	
Iu (U-phase current)	c21	First decimal place	
Iw (W-phase current)	c22	First decimal place	
Idc (BUS current)	c23	First decimal place	
Vdc (BUS voltage)	c24	Integer	
Flow rate (calculated based on the flow-rate sensor reading)	c25	First decimal place	
ΔLEV opening 1	c29	Integer	
High-pressure suppression control judgment value HP03	c31	Second decimal place	
TH16 water temperature (unit)	c33	First decimal place	
TH17 water temperature (unit)	c34	First decimal place	
Shell temperature	c39	First decimal place	
INJ LEV opening	c40	Integer	

(Note1) Item codes 1 through 18 indicate error histories. Each history has the error code, error detail code, and time as a set.

(Note2) Error histories are displayed from the newest to the oldest. (Each history has the error code, error detail code, and time as a set.)  
Up to the past six histories can be displayed. (The older ones will be deleted.)

(Note3) If the error history is empty, "----" will blink.

(Note4) Refer to section "[1] Maintenance items" for details. (page 121)

2. Operation status before error

**Setting procedure**

**Step 1**  
Set the dip switches SW2 and SW3.

Set the dip switches on the circuit board as follows to view the operation status before error.

SW2	SW3					
10	5	6	7	8	9	10
ON	OFF	OFF	OFF	OFF	OFF	OFF

**Step 2**  
Select the desired item with the push switch SWP3.

Press the push switch SWP3 to toggle through the item codes listed below.

**Step 3**  
Press the push switches SWP1 (↑) or SWP2 (↓) to increase or decrease the value.

Select an item code, and press either of the push switches SWP1 or SWP2 to display the data acquisition time (operation data before error; 0 minute before = error occurrence time) and data type. They will appear alternately at one-second intervals. Every time SWP2 is pressed, the time will go back by one minute, and the time and the temperature (or pressure) will appear alternately at one-second intervals. Each time SWP1 is pressed, the time will advance by one minute, and the time and the temperature (or pressure) will appear alternately at one-second intervals. The time immediately before the occurrence of error is defined as 0, and the time can go back up to 19 minutes in one-minute increments. Up to 20 collections of data can be viewed for each operation data.

Refer to "Time of data storage before error" on the next page for the types of errors that appear on error history.

**Step 4**  
Press the push switch SWP3 to save the change.

Press SWP3 to stop the blinking and return to the item code display.

**Time of data storage before error**

Item	Item code	LED display
Current inlet water temperature $T_{wi}$	c01	First decimal place
Current outlet water temperature $T_{wo}$	c02	First decimal place
Outdoor temperature $T_a$	c03	First decimal place
TH15 water temperature (unit)	c04	First decimal place
Refrigerant suction temperature	c05	First decimal place
Refrigerant discharge temperature	c06	First decimal place
Refrigerant temperature at gas cooler outlet	c07	First decimal place
Refrigerant temperature at air heat exchanger inlet	c08	First decimal place
Refrigerant temperature at air heat exchanger outlet	c09	First decimal place
LEV opening	c10	Integer
High pressure	c12	Second decimal place
Low pressure	c13	Second decimal place
Compressor frequency	c14	Integer
SH (target superheat)	c15	First decimal place
SH (actual superheat)	c16	First decimal place
Inverter pump opening	c17	First decimal place
Valve opening (pulse)	c18	Integer
Heatsink temperature (THHS)	c19	First decimal place
$I_u$ (U-phase current)	c21	First decimal place
$I_w$ (W-phase current)	c22	First decimal place
$I_{dc}$ (BUS current)	c23	First decimal place
$V_{dc}$ (BUS voltage)	c24	Integer
Flow rate (calculated based on the flow-rate sensor reading)	c25	First decimal place
$\Delta$ LEV opening 1	c29	Integer
High-pressure suppression control judgment value HP03	c31	Second decimal place
TH16 water temperature (unit)	c33	First decimal place
TH17 water temperature (unit)	c34	First decimal place
Shell temperature	c39	First decimal place
INJ LEV opening	c40	Integer

(Note1) Each circuit board displays error data of its own unit and not other units.

(Note2) "Before error" is defined as the period between 19 minutes before the occurrence of an error up to immediately before the occurrence of the error.

3. Maintenance setting 1

This category includes items that are set during test run and maintenance.

**Setting procedure**

**Step 1**  
Set the dip switches SW2 and SW3.

Set the dip switches on the circuit board as follows.

SW2	SW3					
10	5	6	7	8	9	10
OFF	OFF	OFF	OFF	ON	OFF	OFF

**Note**

By setting SW3-9 to ON after setting the dip switches SW2 and SW3 as shown left, the setting values can be checked.  
(The settings cannot be changed.)

**Step 2**  
Select the desired item with the push switch SWP3.

Press the push switch SWP3 to toggle through the item codes listed below. Press the push switches SWP2 and SWP3 to change the value of the selected item.

**Step 3**  
Press the push switches SWP1 (↑) or SWP2 (↓) to increase or decrease the value.

Refer to the table below for information about the items that can be set.

**Step 4**  
Press the push switch SWP3 to save the change.

Press SWP3 once within one minute of changing the setting with SWP1 or SWP2 to save the setting. Once the new setting is saved, the display will stop blinking and stay lit. The display will, then, return to the item code display mode. If SWP3 is not pressed within one minute, the change will not be saved, and the display will return to the item code display mode.

	Item code	Increments	Lower limit	Upper limit	Initial value
Sensor method setting	1214	1	0	2	0

- 0: Local control method
- 1: Three-sensor method
- 2: Six-sensor method

**Settings table**

Items that can be set	Item code	Initial value	Unit	Limits and increments		
				Increments	Lower limit	Upper limit
Mode 1 Thermo-ON thermistor selection	1500	3	-	1	1	3 (6*)
Mode 1 Thermo-OFF thermistor selection	1501	3	-	1	1	3 (6*)
Mode 2 Thermo-ON thermistor selection	1502	1	-	1	1	3 (6*)
Mode 2 Thermo-OFF thermistor selection	1503	2	-	1	1	3 (6*)
Mode 3 Thermo-ON thermistor selection	1504	1	-	1	1	3 (6*)
Mode 3 Thermo-OFF thermistor selection	1505	3	-	1	1	3 (6*)
Number of water control modes	1507	1	-	1	1	3
Mode 1 Thermo differential value	1508	10	°C	1	0	30
Mode 2 Thermo differential value	1509	10	°C	1	0	30
Mode 3 Thermo differential value	1510	10	°C	1	0	30

\* Only for six-sensor method  
Thermistor number 1: TH15, 2: TH16, 3: TH17

## [2] Troubleshooting

1. If a problem occurs, please check the following. If a protection device has tripped and brought the unit to stop (when an error code is blinking on the LED), resolve the cause of the error before resuming operation. Resuming operation without removing the causes of an error may damage the unit and its components.

Problem	Check item		Cause		Solution
The unit does not operate.	The fuse in the control box is not blown.	The power lamp on the circuit board is not lit.	The main power is not turned on.		Switch on the power.
		The power lamp on the circuit board is lit.	The pump interlock circuit is not connected.	Connect the pump interlock circuit wiring to the system.	
			The flow switch wiring is not connected.	Connect the flow switch wiring to the system.	
The fuse in the control box is blown.	Measure the circuit resistance and the earth resistance.	Short-circuited circuit or ground fault		Resolve the cause, and replace the fuse.	
The compressor does not operate.	Protection devices have not tripped.	INV board problem		Repair or replace the INV board.	
		Noise filter board problem		Repair or replace the noise filter board.	
	High-pressure cutout switch has tripped. 1302	Abnormal high pressure	Dirty condenser (scaling formation)	Clean the condenser.	
			Air in the refrigerant circuit	Vacuum the refrigerant circuit, and charge it with refrigerant.	
			Water flow shortage	Secure enough water flow rate.	
	The discharge temperature thermistor has tripped. 1102	LEV fault in the main circuit		Replace the LEV in the main circuit.	
		Injection LEV fault		Replace the injection LEV.	
		Injection solenoid valve fault		Replace the solenoid valve.	
		Refrigerant gas leakage		Leakage test	
		Refrigerant undercharge	Repair the cause of refrigerant shortage, evacuate the system, and charge the refrigerant circuit with refrigerant.		
	A thermistor error was detected. 5101~5118	Broken or short-circuited thermistor wiring		Check the thermistor wiring for broken connections or short circuit. Replace the thermistor.	
	Overcurrent passed through the compressor. 4250	Compressor motor		Replace the compressor.	
		Overload operation		Check the operation patterns.	
Seized compressor shaft		Replace the compressor.			
The pump interlock has tripped.	The pump interlock circuit is not connected.		Connect the pump interlock wiring.		
	The water pump is not operating.		Operate the pump.		
	Problem with the solenoid contactor for the pump		Replace the solenoid contactor.		
The flow switch has tripped.	The flow switch wiring is not connected.		Connect the flow switch wiring to the system.		
	Water flow shortage		Increase the water flow rate.		
	Flow switch contact failure		Polish the contact point.		
Automatic Start/Stop thermistor has tripped.	The water temperature has reached above the preset temperature.		Normal		
The motor whines, but will not turn.	Contact failure at a connector terminal		Polish the contact point.		
	Loose wire connection		Tighten the wire connection.		
	Seized compressor or fan bearing		Disassemble the compressor or the fan, and repair as necessary.		
	High-pressure is too high.		Check the operation patterns.		
A momentary overcurrent was detected.	Burned, short-circuited, or ground faulted motor		Replace the compressor, and clean the refrigerant circuit.		

[ IX Troubleshooting ]

Problem	Check item		Cause	Solution	
The unit has stopped during operation and does not restart.	Automatic Start/Stop thermistor has tripped.	Water temperature is high.		Normal	
		Water temperature is low.	The setting for the automatic Start/Stop thermistor is too low.	Change the setting for the automatic Start/Stop thermistor.	
	The high-pressure switch has tripped. 1302	Water temperature is not high.	Dirty condenser		Clean the condenser.
			Refrigerant overcharge		Evacuate the system, and charge the system with refrigerant.
			Air in the refrigerant circuit		Evacuate the system, and charge the system with refrigerant.
			Water flow shortage		Secure enough water flow rate.
	The vacuum protection has tripped. 1301	Outside temperature is not low.	Refrigerant undercharge, refrigerant gas leakage		Perform a leakage test, repair the leaks, evacuate the system, and charge the refrigerant circuit with refrigerant.
			Dirty evaporator		Clean the evaporator.
			Air flow shortage		Check the evaporator fan for proper operation, and replace it if necessary.
			LEV fault in the main circuit		Replace the LEV in the main circuit.
			Clogged strainer		Replace the strainer.
			Clogged check valve		Replace the check valve.
			Excessive frosting		Install a snow hood to keep snow from accumulating on the unit.
	The discharge temperature thermistor has tripped. 1102	Suction gas is overheated.	Refrigerant undercharge, refrigerant gas leakage		Perform a leakage test, repair the leaks, evacuate the system, and charge the refrigerant circuit with refrigerant.
			LEV fault in the main circuit		Replace the LEV in the main circuit.
			Injection LEV actuation failure		Replace the injection LEV.
			Injection solenoid valve fault		Replace the injection solenoid valve.
			Clogged strainer		Replace the strainer.
			The cooling fan is stopped.		Check the evaporator fan for proper operation, and replace it if necessary.
			High pressure is too high.		Check the items above and make necessary adjustments so that the suction gas temperature falls within the specified temperature range.
Overcurrent passed through the compressor. 4250	Outside temperature is high.	Overload operation Burnt motor Seized compressor		Reduce the operation load, and check the operation patterns. Replace the compressor.	
A water supply cutoff was detected. 2601	The pump is operating normally.	Water flow shortage		Increase the water flow rate.	
		Flow switch fault		Replace the flow switch.	
	The pump does not operate.	Problem with the solenoid contactor for the pump		Replace the electromagnetic contactor.	
		Pump fault		Replace the pump.	
The unit has stopped during operation and does not restart. (when the secondary-side control is enabled)	A secondary circuit water supply cutoff was detected. 2601(2)	The pump is operating normally.	Water flow shortage on the secondary-side pump	Check the water pipe on the secondary side for foreign matters.	
			Secondary-side flow sensor fault	Check the flow sensor and replace as necessary.	
		The pump does not operate.	Pump fault	Replace the pump.	
	Error code 5118 was detected.		External Water sensor (secondary circuit) fault	External Replace the water sensor (secondary circuit).	
The unit is in operation, but the water does not heat up.	Water temperature is low.	The water inlet/outlet temperature differential is normal.	The water-heating load is too high.	Install more units	
			Low refrigerant charge due to a leak.	Perform a leakage test, repair the leaks, evacuate the system, and charge the refrigerant circuit with refrigerant.	
		The water inlet/outlet temperature differential is small.	LEV fault in the main circuit	Replace the LEV in the main circuit.	
			Compressor failure	Replace the compressor.	
			High pressure is too high, or low pressure is too low.	Operate the units within the specified pressure range.	
	Water temperature is high.		Water flow shortage	Increase the water flow rate.	
			Problem with the external devices	Repair the devices.	

[ IX Troubleshooting ]

Problem	Check item		Cause	Solution	
The unit is in operation, but the secondary circuit water is not correct. (when the secondary-side control is enabled)	Supply-water temperature on the secondary side is high.	The difference between the supply-water temperature on the primary side and the secondary side is too small.	Water flow shortage on the secondary-side pump	Reconfigure the system to increase the maximum flow rate on the secondary-side circuit. (e.g., Change the pump.)	
	Supply-water temperature on the secondary side is low.	The difference between the supply-water temperature on the primary side and the secondary side is too large.	Excess water flow on the secondary-side pump	Reconfigure the system to decrease the minimum flow rate on the secondary-side circuit. (e.g., Change the pump.)	
			Secondary-side flow sensor fault	Check the flow sensor and replace as necessary.	
			Error code 2616 (1) was detected.	Capacity drop of the heat exchanger	Service or replace the heat exchanger.
			Error code 2616 (2) was detected.	Capacity shortage of the heat exchanger	Replace the heat exchanger.
The unit is making a great deal of vibrations and noise.	The compressor is being flooded.		LEV fault in the main circuit	Replace the LEV.	

2. Diagnosing Problems Using Error Codes

If a problem occurs, please check the following before calling for service.

- (1) Check the error code against the table below.
- (2) Check for possible causes of problems listed in the "Cause" column that correspond to the error code.
- (3) If the error codes that appear on the display are not listed in the table below, or no problems were found with the items listed in the "Cause" column, please consult your dealer or servicer.

**Diagnosing Problems Using Error Codes**

Error code *1 (PCB *2 RC M-NET)	Error type	Cause (Installation/Setting error)	Cause (Parts problems)	Error reset *3	
				Unit side (PCB)	Remote
				SWS1	Operation SW
0 100	Unreset errors	Some of the errors have not been reset.		—	—
4 106 (254)	Power failure • If a power supply is not detected after the M-NET power supply was turned on, Error code 4106 will appear, and the unit will come to an abnormal stop.	Power failure occurred when the operation switch is switched on.		⊙	⊙
4 106 (255)	Power supply fault		• Transmission power board fault	—	—
26 13	Water flow drop • If residual operation of the pump does not stop after a certain period has passed due to a decrease in flow rate, Error code 2613 will appear. The unit will remain in operation.		• Water flow control valve fault • Pump fault	○	○
130 1	Vacuum protection fault	• Outside temperature is below the minimum usage temperature. • Sudden frosting or heavy snow has clogged the heat exchanger.	• Low-pressure sensor fault • Suction refrigerant temperature thermistor fault • Electric expansion valve fault on the main circuit • Fan motor error/broken motor wire • Refrigerant shortage (gas leakage)	○	○
1302	High pressure fault • After the high-pressure switch has detected absence of voltage a certain number of times or if it is detected that the pressure has remained at or above 14 MPa for 20 seconds or longer, Error code 1302 will appear, and the unit will come to an abnormal stop.		• Electronic expansion valve fault • High-pressure sensor fault • Water flow control valve fault • Pump fault	○	○
1 104	Low evaporation temperature fault		• Low-pressure sensor fault • Suction refrigerant temperature thermistor fault • Electric expansion valve fault on the main circuit • Fan motor error/broken motor wire • Refrigerant shortage (gas leakage)	○	○
260 1	Water supply cutoff (Water flow rate sensor) • If the unit has remained in operation for a certain duration with the flow rate being low in the unit-side water circuit, Error code 2601 will appear, and the unit will come to an abnormal stop.	Water flow drop	• Water flow control valve fault • Pump fault • Water flow rate sensor	○	○
260 1 (2)	Secondary side water supply cutoff error • If the unit has remained in operation for a certain duration with the secondary-side control being enabled and the flow rate being low in the secondary-side water circuit, Error code 2601 and 2602 will appear alternately, and the unit will come to an abnormal stop.	Water circuit air entrainment, water strainer clogged	Flow sensor fault, pump fault, motor-operated valve fault, water flow rate control valve fault	○	○
2 138	Outlet water temperature fault (low temp) • If it is detected that the outlet water temperature has remained at a temperature of 15 degrees or below the target temperature or a temperature at or below 50°C for 5 minutes, Error code 2138 will appear, and the unit will come to an abnormal stop.		• Fan motor error/broken motor wire • Refrigerant shortage (gas leakage)	○	○



[ IX Troubleshooting ]

Error code *1 (PCB *2 RC M-NET)	Error type	Cause (Installation/Setting error)	Cause (Parts problems)	Error reset *3	
				Unit side (PCB)	Remote
				SWS1	Operation SW
5 101	Thermistor fault Discharge temp sensor (TH1) • If it is detected that the discharge temperature sensor (TH1) is open- or short-circuited for continuous 20 seconds or longer, Error code 5101 will appear, and the unit will come to an abnormal stop.		Broken or shorted thermistor wiring	○	○
5 102	Suction temp sensor (TH2) • If it is detected that the suction temperature sensor (TH2) is open- or short-circuited for continuous 20 seconds or longer, Error code 5102 will appear, and the unit will come to an abnormal stop.		Broken or shorted thermistor wiring	○	○
5 103	Heat exchanger outlet refrigerant temp sensor (TH3) • If it is detected that the heat exchanger outlet refrigerant temperature sensor (TH3) is open- or short-circuited for continuous 20 seconds or longer, Error code 5103 will appear, and the unit will come to an abnormal stop.		Broken or shorted thermistor wiring	○	○
5 104	Air-side heat exchanger inlet refrigerant temp sensor (TH4) • If it is detected that the air-side heat exchanger inlet refrigerant temperature sensor (TH4) is open- or short-circuited for continuous 20 seconds or longer, Error code 5104 will appear, and the unit will come to an abnormal stop.		Broken or shorted thermistor wiring	○	○
5 105	Air-side heat exchanger outlet refrigerant temp sensor (TH5) • If it is detected that the air-side heat exchanger outlet refrigerant temperature sensor (TH5) is open- or short-circuited for continuous 20 seconds or longer, Error code 5105 will appear, and the unit will come to an abnormal stop.		Broken or shorted thermistor wiring	○	○
5 109	Outside temp sensor (TH9) • If it is detected that the outside temperature sensor (TH9) is open- or short-circuited for continuous 20 seconds or longer, Error code 5109 will appear, and the unit will come to an abnormal stop.		Broken or shorted thermistor wiring	○	○
5 111	Outlet water temp sensor (TH11) • If it is detected that the outlet water temperature sensor (TH11) is open- or short-circuited for continuous 20 seconds or longer, Error code 5111 will appear, and the unit will come to an abnormal stop.		Broken or shorted thermistor wiring	○	○
5 112	Inlet water temp sensor (TH12)		Broken or shorted thermistor wiring	○	○
5 114	Shell temp sensor (TH14) • If it is detected that the shell temperature sensor (TH14) is open- or short-circuited for continuous 20 seconds or longer, Error code 5114 will appear, and the unit will come to an abnormal stop.		Broken or shorted thermistor wiring	○	○
5 115	External water sensor1 (TH15) • If it is detected that the external water sensor 1 (TH15) is open- or short-circuited for continuous 20 seconds or longer, Error code 5115 will appear, and the unit will come to an abnormal stop.		Broken or shorted thermistor wiring	○	○
5 116	External water sensor2 (TH16) • If it is detected that the external water sensor 2 (TH16) is open- or short-circuited for continuous 20 seconds or longer, Error code 5116 will appear, and the unit will come to an abnormal stop.		Broken or shorted thermistor wiring	○	○
5 117	External water sensor3 (TH17) • If it is detected that the external water sensor 3 (TH17) is open- or short-circuited for continuous 20 seconds or longer, Error code 5117 will appear, and the unit will come to an abnormal stop.		Broken or shorted thermistor wiring	○	○
5 118 (when the secondary side control is enabled)	Secondary side water sensor (TH18) • If it is detected that the secondary side water sensor (TH18) is open- or short-circuited for continuous 20 seconds or longer, Error code 5118 will appear, and the unit will come to an abnormal stop.		Broken or shorted thermistor wiring	○	○

[ IX Troubleshooting ]

Error code *1 (PCB *2 RC M-NET)	Error type	Cause (Installation/Setting error)	Cause (Parts problems)	Error reset *3	
				Unit side (PCB)	Remote
				SWS1	Operation SW
5201	High-pressure sensor fault/high-pressure fault • If it is detected that the high-pressure sensor is open- or short-circuited for continuous 20 seconds or longer, Error code 5201 will appear, and the unit will come to an abnormal stop.		Broken or shorted pressure sensor wiring	○	○
5202	Low-pressure sensor fault/low-pressure fault • If it is detected that the low-pressure sensor is open- or short-circuited for continuous 20 seconds or longer, Error code 5202 will appear, and the unit will come to an abnormal stop.		Broken or shorted pressure sensor wiring	○	○
1102	Discharge temperature fault • If the discharge temperature reaches above 130°C while the compressor is in operation, Error code 1102 will appear, and the unit will come to an abnormal stop.		<ul style="list-style-type: none"> <li>Water flow control valve fault</li> <li>Pump fault</li> <li>High-pressure sensor fault</li> <li>Discharge refrigerant thermistor fault</li> <li>Linear expansion valve fault (Main circuit LEV, injection LEV)</li> <li>Refrigerant shortage (gas leakage)</li> </ul>	○	○
1105	Heat exchanger outlet temperature fault • If the refrigerant temperature at gas cooler outlet of 80°C or higher is detected for 20 seconds or longer, Error code 1105 will appear, and the unit will come to an abnormal stop.		<ul style="list-style-type: none"> <li>Water flow control valve fault</li> <li>Pump fault</li> </ul>	○	○
1502	Liquid refrigerant floodback • If the discharge temperature remains low despite the fact that the LEV opening is being decreased by the LEV control function, Error code 1502 will appear, and the unit will come to an abnormal stop.		<ul style="list-style-type: none"> <li>Fan motor error/broken motor wire</li> <li>Low-pressure sensor fault</li> <li>Discharge refrigerant temperature thermistor fault</li> <li>Electronic expansion valve fault</li> </ul>	○	○
7113	Model setting error 1 • If the pins 1 through 4 on SW01 are set incorrectly, Error code 7113 will appear, and the unit will come to an abnormal stop.	Dip switches on the PCB were set incorrectly during maintenance.		×	×
7117	Model setting error 2 • If the unit model identification resistor (TYP) is set incorrectly, Error code 7117 will appear, and the unit will come to an abnormal stop.		• Resistor Z21 fault (connected to the Main control board)	×	×
4115	Power supply frequency fault • If the power-supply frequency goes out of range while the power is turned on, Error code 4115 will appear, and the unit will come to an abnormal stop.	Power supply frequency is a frequency other than 50 Hz or 60 Hz.		×	×
4102	Open phase	There is an open phase.	• Circuit board fault	×	×

[ IX Troubleshooting ]

Error code *1 (PCB *2 RC M-NET)	Error type		Cause (Installation/Setting error)	Cause (Parts problems)	Error reset *3		
					Unit side (PCB)	Remote	
					SWS1	Operation SW	
4250 4255 (101)	Inverter error	Electric current related errors during operation	IPM error	<ul style="list-style-type: none"> <li>INV board fault (4250)</li> <li>Fan board fault (4255)</li> <li>Ground fault of the compressor</li> <li>Coil problem</li> <li>IPM error (loose terminal screws, cracked due to swelling)</li> <li>Items listed under "Heatsink overheat protection" below</li> </ul>	○	○	
			ACCT overcurrent		<ul style="list-style-type: none"> <li>INV board fault (4250)</li> <li>Fan board fault (4255)</li> <li>Ground fault of the compressor</li> <li>Coil problem</li> <li>IPM error (loose terminal screws, cracked due to swelling)</li> </ul>	○	○
			DCCT overcurrent			○	○
			Overcurrent relay trip (momentary value) (During operation)			○	○
			Overcurrent relay trip (effective value) (During operation)			○	○
			Short-circuited IPM/ground fault (During operation)			<ul style="list-style-type: none"> <li>Ground fault of the compressor</li> <li>IPM error (loose terminal screws, cracked due to swelling)</li> </ul>	○
			Overcurrent error due to a short-circuited (During operation)		<ul style="list-style-type: none"> <li>Ground fault of the compressor</li> <li>Shorted output wiring</li> </ul>		○
4250 4255 (101)	Current related problems at start up		IPM error (At startup)	<ul style="list-style-type: none"> <li>INV board fault (4250)</li> <li>Fan board fault (4255)</li> <li>Ground fault of the compressor</li> <li>Coil problem</li> <li>IPM error (loose terminal screws, cracked due to swelling)</li> <li>Items listed under "Heatsink overheat protection" below</li> </ul>		○	○
			ACCT overcurrent (At startup)		<ul style="list-style-type: none"> <li>INV board fault (4250)</li> <li>Fan board fault (4255)</li> <li>Ground fault of the compressor</li> <li>Coil problem</li> <li>IPM error (loose terminal screws, cracked due to swelling)</li> </ul>	○	○
			DCCT overcurrent (At startup)			○	○
			Overcurrent relay trip (momentary value) (At startup)			○	○
			Overcurrent relay trip (effective value) (At startup)			○	○

[ IX Troubleshooting ]

Error code *1 (PCB *2 RC M-NET)	Error type		Cause (Installation/Setting error)	Cause (Parts problems)	Error reset *3		
					Unit side (PCB)	Remote	
					SWS1	Operation SW	
4220 4225 (108)	Inverter error	Voltage related problems during operation	Bus voltage drop protection	Momentary power failure/power failure Power supply voltage drop (Inter-phase voltage is 180 V or below.) Voltage drop	<ul style="list-style-type: none"> <li>INV board CNDC2 wiring fault</li> <li>INV board fault (4220)</li> <li>Fan board fault (4225)</li> <li>72C fault</li> <li>Diode stack failure</li> </ul>	○	○
4220 4225 (109)			Bus voltage rise protection	Incorrect power supply voltage	<ul style="list-style-type: none"> <li>INV board fault (4220)</li> <li>Fan board fault (4225)</li> </ul>	○	○
4220 4225 (111)			Logic error	Malfunction due to external noise interference <ul style="list-style-type: none"> <li>Faulty grounding</li> <li>Improper transmission and external wiring installation (Shielded cable is not used.)</li> <li>Low-voltage signal wire and high-voltage wire are in contact. (Placing the signal wire and power wire in the same conduit)</li> </ul>	<ul style="list-style-type: none"> <li>INV board fault (4220)</li> <li>Fan board fault (4225)</li> </ul>	○	○
4220 4225 (131)		Voltage meter error at start up (Bus voltage drop protection at start up (detected by the Main unit side))	Power supply voltage drop	<ul style="list-style-type: none"> <li>INV board fault (4220)</li> <li>Fan board fault (4225)</li> </ul>	○	○	
4230 4235		Heatsink fault (Heatsink overheat protection)	Power supply voltage drop (Inter-phase voltage is 180 V or below.) Clogged heatsink cooling air passage	<ul style="list-style-type: none"> <li>Fan motor fault</li> <li>INV board fan output fault</li> <li>THHS sensor fault</li> <li>IPM error (loose terminal screws, cracked due to swelling)</li> </ul>	○	○	
4240 4245		Overload protection	Short-cycling of air (reduced air flow) Clogged heatsink cooling air passage Power supply voltage drop (Inter-phase voltage is 180 V or below.)	<ul style="list-style-type: none"> <li>THHS sensor fault</li> <li>Current sensor fault</li> <li>INV board fan output fault</li> <li>INV circuit fault</li> <li>Compressor fault</li> </ul>	○	○	
5301 5305 (115)		ACCT sensor fault		<ul style="list-style-type: none"> <li>INV board fault</li> <li>Ground fault of the compressor and IPM error</li> </ul>	○	○	
5301 5305 (116)		DCCT sensor		<ul style="list-style-type: none"> <li>Poor contact at the INV board connector CNCT</li> <li>Poor contact at the INV board connector DCCT</li> <li>Ground fault of the compressor and IPM error</li> </ul>	○	○	
5301 5305 (117)		ACCT sensor/circuit fault		<ul style="list-style-type: none"> <li>Poor contact at the INV board connector CNCT2 (ACCT)</li> <li>ACCT sensor fault</li> </ul>	○	○	
5301 5305 (118)		DCCT sensor/circuit fault		<ul style="list-style-type: none"> <li>Poor contact at the INV board connector CNCT</li> <li>Poor contact at the INV board connector DCCT</li> <li>DCCT sensor fault</li> <li>INV board fault</li> </ul>	○	○	
5301 5305 (119)		Open-circuited IPM/loose ACCT sensor		<ul style="list-style-type: none"> <li>Disconnected ACCT sensor (CNCT2)</li> <li>ACCT sensor fault</li> <li>Broken compressor wiring</li> <li>INV circuit fault (IPM error etc.)</li> </ul>	○	○	
5301 5305 (120)		Faulty wiring		<ul style="list-style-type: none"> <li>ACCT sensor is connected in the wrong phase.</li> <li>ACCT sensor is connected in the wrong orientation.</li> </ul>	○	○	
5110 (01) (05)		THHS sensor/circuit fault		<ul style="list-style-type: none"> <li>THHS sensor contact failure</li> <li>THHS sensor fault</li> <li>INV board fault</li> </ul>	○	○	
0403 (01) (05)		Serial communication error		<ul style="list-style-type: none"> <li>Communication error between control board and INV board (noise interference, broken wiring)</li> </ul>	○	○	
—		IPM system error	INV board switch setting error	<ul style="list-style-type: none"> <li>Wiring or connector connection between connectors on IPM-driven power supply circuit</li> <li>INV board fault</li> </ul>	○	○	

[ IX Troubleshooting ]

Error code *1 (PCB *2 RC M-NET)	Error type	Cause (Installation/Setting error)	Cause (Parts problems)	Error reset *3		
				Unit side (PCB)	Remote	
				SWS1	Operation SW	
6830	Remote controller error (incl. remote controller wiring fault)	Address overlap	There are two or more of the same address.		×	×
7109		Non-consecutive address, system error	Address setting error (Non-consecutive address)		×	×
6831		Remote controller signal reception error 1	Remote controller cable is not connected. Broken wiring	<ul style="list-style-type: none"> <li>Broken remote controller wiring</li> <li>Main control board communication circuit fault</li> </ul>	—	—
6832		Remote controller signal transmission error	Communication error due to external noise interference	Main control board communication circuit fault	—	—
6833		Remote controller over current	Remote controller cable is short		×	×
6834		Remote controller signal reception error 2	Communication error due to external noise interference	Main control board communication circuit fault	—	—
7130	Multiple system error	Incompatible combination of units <ul style="list-style-type: none"> <li>When one or more of the following applies, Error code 7130 will appear, and the unit will come to an abnormal stop. <ul style="list-style-type: none"> <li>Incorrect attribute code</li> <li>The M-NET address of the outdoor unit to which a pair of tanks are connected is incorrect.</li> <li>No auxiliary sensor was detected in the system.</li> </ul> </li> </ul>	Different types of units are connected to the same system.		×	×
7102		No.-of-connected-unit setting is incorrect. <ul style="list-style-type: none"> <li>When one or more of the following applies, Error code 7102 will appear, and the unit will come to an abnormal stop. <ul style="list-style-type: none"> <li>The number of units entered in the system and the actual number of units do not match.</li> <li>Sub unit addresses are not assigned sequentially.</li> <li>One or more sub unit addresses are outside the range (1-50).</li> <li>Units other than sub units were detected. (Auxiliary sensors are treated as sub units.)</li> </ul> </li> </ul>	No.-of-connected-unit setting is incorrect (Main unit).		×	×
4126 (I)	Analog input error (Control board (MAIN) CN421)	Analog input type fault Set Item code 1075	Broken or Open 4-20mA signal output device wiring (CN421)		○	○
6500	Communication error between the main and sub units Communication error between the MAIN and SUB circuits				—	—
6600	Transmission line power supply PCB fault	Communication error due to external noise interference	<ul style="list-style-type: none"> <li>Broken wiring to the transmission power supply circuit board (between the main and sub units)</li> <li>Transmission power supply PCB communication circuit fault</li> </ul>	⊙	⊙	
6602	Communication error between the main and sub units (Simple multiple unit control mode)					
6603						
6606						
6607						
6608						
5701	Water flow adjusting valve limit switch error <ul style="list-style-type: none"> <li>If the limit switch does not work properly at the initial control stage or when the command signal is sent to fully open the valves, Error code 5701 will appear, but the unit will remain in operation.</li> </ul>		Water flow rate control valve fault		×	×
2518	Secondary side hot water temperature reduction error <ul style="list-style-type: none"> <li>If the following conditions are detected for five continuous minutes, Error code 2518 will appear, but the unit will remain in operation. (Secondary-side hot supply-water temperature ≤ 50°C) and (Secondary-side hot supply-water temperature ≤ Secondary-side target hot supply-water temperature T2m-15°C) or Secondary-side hot supply-water temperature ≤ Outlet water temperature-30°C or (Secondary-side hot supply-water temperature ≤ 40°C) and (Outlet water temperature ≥ 49°C) and (Outlet water temperature ≥ Target hot supply-water temperature Tshw-16°C)</li> </ul>	Insufficient pump capacity Outdoor air temperature is below operating range lower limit	Secondary side pump fault Secondary side heat exchanger deteriorated Flow sensor fault		○	○
2616 (I)	Secondary side heat exchanger error (Deterioration of heat exchanger) <ul style="list-style-type: none"> <li>If the hot supply-water temperature difference between the primary-side and the secondary-side has greatly changed from the time of installation (with the secondary-side control function being enabled), Error code 2616 will appear, but the unit will remain in operation.</li> </ul>	Heat exchanger deteriorated			○	○
2616 (2)	Secondary side heat exchanger error (Heat exchanger selection error) <ul style="list-style-type: none"> <li>If the hot supply-water on the secondary side has not reached the target temperature for a long time despite the fact that the hot supply-water on the primary side has reached the maximum temperature, Error code 2616 will appear, but the unit will remain in operation.</li> </ul>	Initial heat exchanger selection error			○	○

- \*1: The codes in the parentheses in the "Error code" column indicate error detail codes.
- \*2: If an error occurs, error codes shown above will appear in the 4-digit digital display on the PCB.
- \*3: Definition of symbols in the "Error reset" column.
  - ⊙: Errors that can be reset regardless of the switch settings
  - : Errors that can be reset if the remote reset setting on the unit is set to "Enable" (factory setting)  
Errors that cannot be reset if the remote reset setting on the unit is set to "Disable"
  - ×: Errors that cannot be reset
  - : Errors that will be automatically cancelled once its cause is removed
- \*4: Power failure will be detected as an error only when the "Automatic recovery after power failure" setting on the unit is set to "Disable."  
(The default setting for the "Automatic recovery after power failure" setting is "Enable.")
- \*5: Depending on the system configuration, if communication error lasts for 10 minutes or longer, units will make an abnormal stop.  
This error can be reset by turning off and then back on the unit's power.
- \*6: This error code will appear when multiple errors occur that are reset in different ways and when one or more of these errors have not been reset. This error can be reset by turning off and then back on the unit's power.
- \*7: Before resetting this error, remove its causes. Resuming operation without removing the causes of heat exchanger freeze up will cause heat exchanger damage.

### [3] Troubleshooting Principal Parts

#### -1- High-Pressure Sensor (63HS)

1. Compare the pressure that is detected by the high pressure sensor, and the high-pressure gauge pressure to check for failure.

Error history, temperature and pressure readings of the sensor, and LEV opening

SW2	SW3					
10	5	6	7	8	9	10
OFF	OFF	OFF	OFF	OFF	OFF	OFF

High pressure and low pressure will appear alternately on the 7-segment LED at P-second intervals (Default: 3 seconds). See below for how they are displayed.



Decimal delimiter

A dot will appear when the compressor is in operation.  
No dot will appear when the compressor is stopped.



Indicates that the high pressure is displayed



Indicates that the low pressure is displayed

**(1) While the sensor is stopped, compare the gauge pressure and the pressure displayed on self-diagnosis LED1.**

- 1) When the gauge pressure is between 0 and 0.098MPa, internal pressure is caused due to gas leak.
- 2) When the pressure displayed on self-diagnosis LED1 is between 0 and 0.098MPa, the connector may be defective or be disconnected. Check the connector and go to (4).
- 3) When the pressure displayed on self-diagnosis LED1 exceeds 15MPa, go to (3).
- 4) If other than 1), 2) or 3), compare the pressures while the sensor is running. Go to (2).

**(2) Compare the gauge pressure and the pressure displayed on self-diagnosis LED1 while the sensor is running. (Compare them by MPa unit.)**

- 1) When the difference between both pressures is within 0.098MPa, both the high pressure sensor and the control board are normal.
- 2) When the difference between both pressures exceeds 0.098MPa, the high pressure sensor has a problem. (performance deterioration)
- 3) When the pressure displayed on self-diagnosis LED1 does not change, the high pressure sensor has a problem.

**(3) Remove the high pressure sensor from the control board to check the pressure on the self-diagnosis LED1.**

- 1) When the pressure displayed on self-diagnosis LED1 is between 0 and 0.098MPa, the high pressure sensor has a problem.
- 2) When the pressure displayed on self-diagnosis LED1 is approximately 15MPa, the control board has a problem.

**(4) Remove the high pressure sensor from the control board, and short-circuit between the No.2 and 3 connectors (63HS:CN63HS) to check the pressure with self-diagnosis LED1.**

- 1) When the pressure displayed on the self-diagnosis LED1 exceeds 15MPa, the high pressure sensor has a problem.
- 2) If other than 1), the control board has a problem.

#### 2. Pressure sensor configuration

The high pressure sensor consists of the circuit shown in the figure below. If DC 5V is applied between the red and the black wires, voltage corresponding to the pressure between the white and the black wires will be output, and the value of this voltage will be converted by the microcomputer. The output voltage is 0.026V per 0.098MPa.

	Control board side
Vcc	Pin 3
Vout	Pin 2
GND	Pin 1

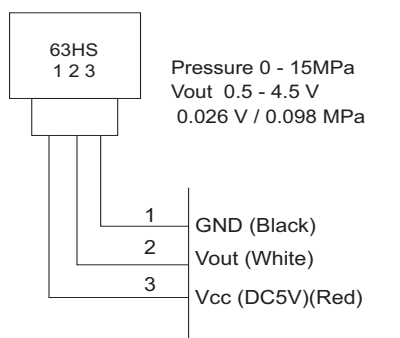

63HS  
1 2 3  
Pressure 0 - 15MPa  
Vout 0.5 - 4.5 V  
0.026 V / 0.098 MPa

$$\text{Pressure [MPa]} = 3.75 \times \text{Vout [V]} - 1.875$$

**-2- Low-Pressure Sensor (63LS)**

1. Compare the pressure that is detected by the low pressure sensor, and the low pressure gauge pressure to check for failure.

**Error history, temperature and pressure readings of the sensor, and LEV opening**

SW2	SW3					
10	5	6	7	8	9	10
OFF	OFF	OFF	OFF	OFF	OFF	OFF

High pressure and low pressure will appear alternately on the 7-segment LED at P-second intervals (Default: 3 seconds). See below for how they are displayed.



Decimal delimiter

A dot will appear when the compressor is in operation.  
No dot will appear when the compressor is stopped.



Indicates that the high pressure is displayed



Indicates that the low pressure is displayed

**(1) While the sensor is stopped, compare the gauge pressure and the pressure displayed on self-diagnosis LED1.**

- 1) When the gauge pressure is between 0 and 0.098MPa, internal pressure is caused due to gas leak.
- 2) When the pressure displayed on self-diagnosis LED1 is between 0 and 0.098MPa, the connector may be defective or be disconnected. Check the connector and go to (4).
- 3) When the pressure displayed on self-diagnosis LED1 exceeds 10MPa, go to (3).
- 4) If other than 1), 2) or 3), compare the pressures while the sensor is running. Go to (2).

**(2) Compare the gauge pressure and the pressure displayed on self-diagnosis LED1 while the sensor is running.(Compare them by MPa unit.)**

- 1) When the difference between both pressures is within 0.03MPa, both the low pressure sensor and the control board are normal.
- 2) When the difference between both pressures exceeds 0.03MPa, the low pressure sensor has a problem. (performance deterioration)
- 3) When the pressure displayed on the self-diagnosis LED1 does not change, the low pressure sensor has a problem.

**(3) Remove the low pressure sensor from the control board to check the pressure with the self-diagnosis LED1 display.**

- 1) When the pressure displayed on the self-diagnosis LED1 is between 0 and 0.098MPa, the low pressure sensor has a problem.
- 2) When the pressure displayed on self-diagnosis LED1 is approximately 10MPa, the control board has a problem.
  - When the outdoor temperature is 40°C or less, the control board has a problem.
  - When the outdoor temperature exceeds 40°C, go to (5).

**(4) Remove the low pressure sensor from the control board, and short-circuit between the No.2 and 3 connectors (63LS:CN63LS) to check the pressure with the self-diagnosis LED1.**

- 1) When the pressure displayed on the self-diagnosis LED1 exceeds 10MPa, the low pressure sensor has a problem.
- 2) If other than 1), the control board has a problem.

**(5) Remove the high pressure sensor (63HS) from the control board, and insert it into the connector for the low pressure sensor (63LS:CN63LS) to check the pressure with the self-diagnosis LED1.**

- 1) When the pressure displayed on the self-diagnosis LED1 exceeds 10MPa, the control board has a problem.
- 2) If other than 1), the control board has a problem.

**2. Low-pressure sensor configuration**

The low pressure sensor consists of the circuit shown in the figure below. If DC5V is applied between the red and the black wires, voltage corresponding to the pressure between the white and the black wires will be output, and the value of this voltage will be converted by the microcomputer. The output voltage is 0.039V per 0.098MPa.

	Control board side
Vcc	Pin 3
Vout	Pin 2
GND	Pin 1

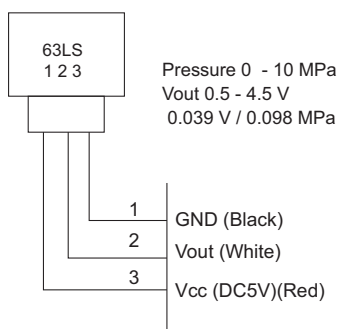

Pressure 0 - 10 MPa  
Vout 0.5 - 4.5 V  
0.039 V / 0.098 MPa

$$\text{Pressure [MPa]} = 2.5 \times \text{Vout [V]} - 1.25$$



### -3- Temperature sensor

Use the flowchart below to troubleshoot the temperature sensor.

#### Troubleshooting the thermistor

(1) Thermistor <Heatsink temperature> : THHS

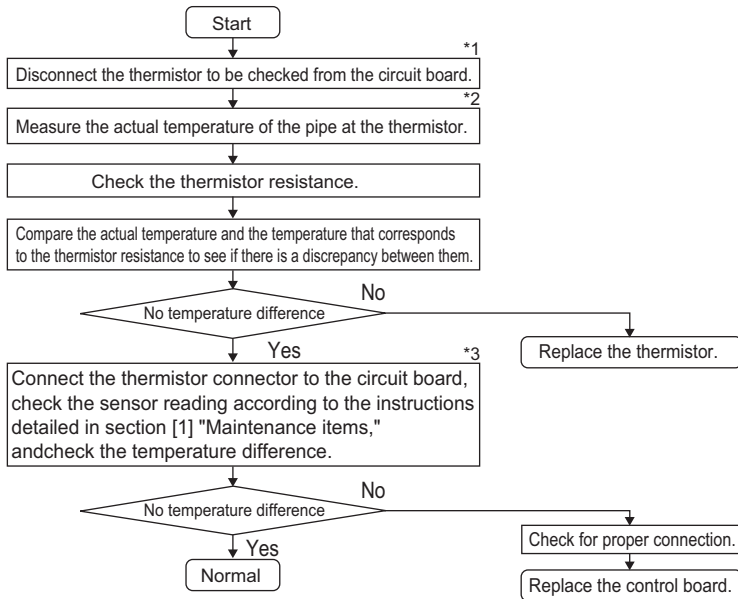

Thermistor  $R_{50} = 17\text{k}\Omega \pm 2\%$   
 $R_t = 17 \exp\left\{4016\left(\frac{1}{273+t} - \frac{1}{323}\right)\right\}$

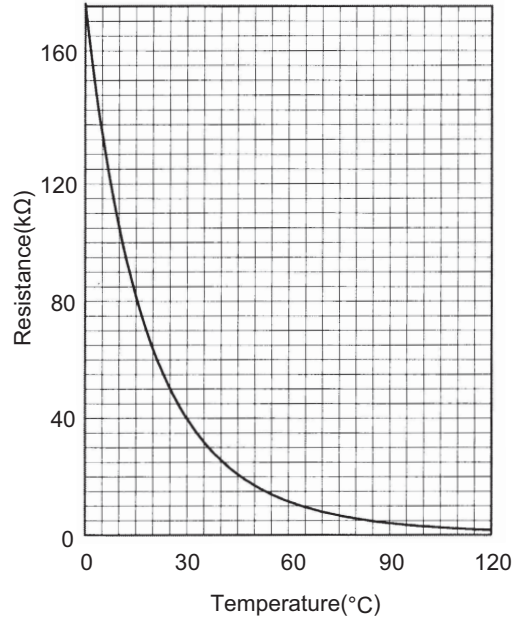

\* 1 The table below shows the thermistor numbers and their corresponding connectors. Check each sensor by disconnecting the corresponding connector.

TH1	CN401	TH9	CN405
TH2	CN402 1-2	TH12	CN407 1-2
TH3	CN402 3-4	TH11	CN407 3-4
TH4	CN404	TH14	CN422 2-3
TH5	CN408		

- \* 2 · Pull out the sensor connector from the I/O board.  
 Do not pull on the lead wire.  
 · Measure the resistance with a tester.  
 · If the measured value is within  $\pm 10\%$  of the value as shown in the table below, the circuit sensor is normal.
- \* 3 Use the dip switches and push switches to view the sensor reading on the LED.

(2) Low-temperature-range thermistor  
 : TH2,3,4,5,9,11,12,14,15,16,17,18

(3) High-temperature-range thermistor: TH1

Thermistor  $R_0 = 15\text{k}\Omega \pm 3\%$   
 $R_t = 15 \exp\left\{3385\left(\frac{1}{273+t} - \frac{1}{273}\right)\right\}$

Thermistor  $R_{120} = 7.465\text{k}\Omega \pm 2\%$   
 $R_t = 7.465 \exp\left\{4057\left(\frac{1}{273+t} - \frac{1}{393}\right)\right\}$

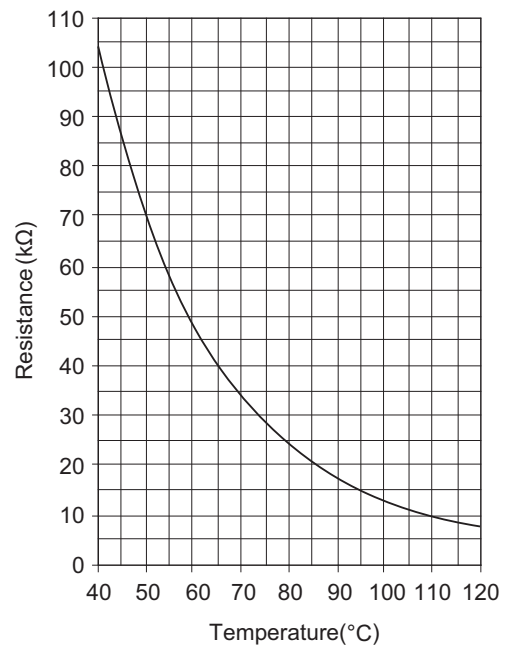
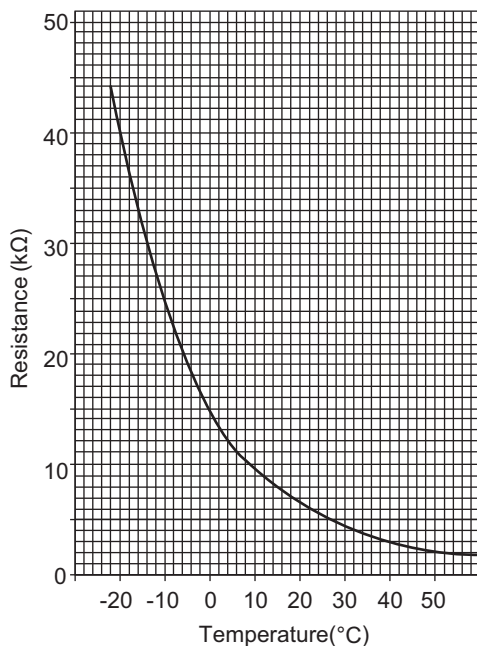

**-4- LEV**

**1. General descriptions of the operation of the LEV in the main circuit**

LEV1 is driven by the pulse signal from the circuit board and is controlled by a stepping motor.

The valve opening changes according to the number of pulses

1) Control board and LEV

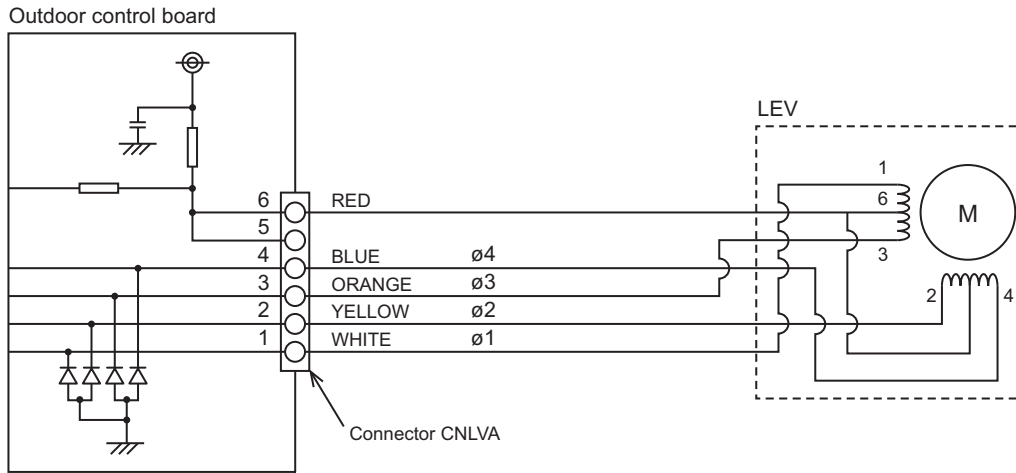

Note. The connector numbers on the intermediate connector and the connector on the control board differ. Check the color of the lead wire to judge the number.

2) Pulse signal output and valve operation

Output (phase) number	Output state							
	1	2	3	4	5	6	7	8
$\phi 1$	ON	ON	OFF	OFF	OFF	OFF	OFF	ON
$\phi 2$	OFF	ON	ON	ON	OFF	OFF	OFF	OFF
$\phi 3$	OFF	OFF	OFF	ON	ON	ON	OFF	OFF
$\phi 4$	OFF	OFF	OFF	OFF	OFF	ON	ON	ON

Output pulses change in the following orders when the Valve is closed; 1 → 2 → 3 → 4 → 5 → 6 → 7 → 8  
 Valve is open; 8 → 7 → 6 → 5 → 4 → 3 → 2 → 1

- \*1. When the LEV opening angle does not change, all the output phases will be off.
- \*2. When the output is open phase or remains ON, the motor cannot run smoothly, and rattles and vibrates.

3) LEV valve closing and opening operation

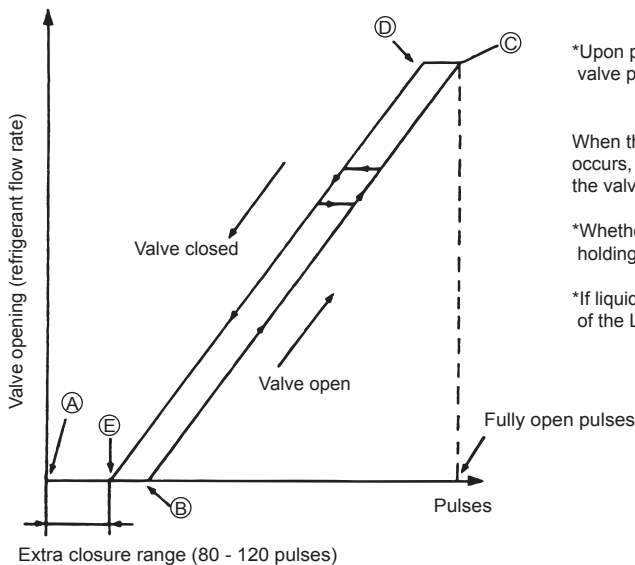

\*Upon power on, a 2260 pulse signal is sent to the LEV to determine the valve position and bring the valve to the position indicated by "A" in the diagram

When the valve operates smoothly, no sound from LEV or no vibration occurs, however, when the pulses change from E to A in the chart and the valve is locked, a big sound occurs.

\*Whether a sound is generated or not can be determined by holding a screwdriver against it, then placing your ear against the handle.

\*If liquid refrigerant is present in the LEV, it may make the operating sound of the LEV difficult to detect.

## 2. General descriptions of injection LEV operation

The valve opening changes according to the number of pulses.

### 1) Control board and LEV

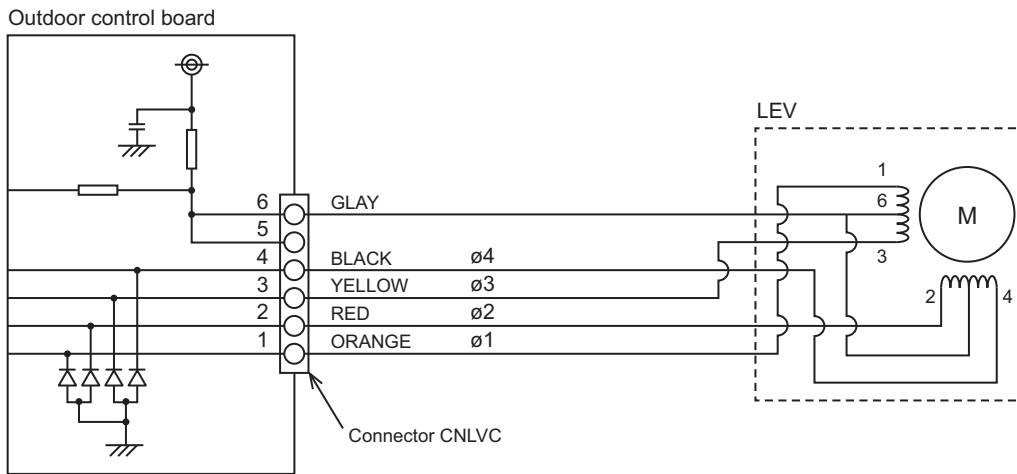

### 2) Pulse signal output and valve operation

Output (phase) number	Output state							
	1	2	3	4	5	6	7	8
$\phi 1$	ON	ON	OFF	OFF	OFF	OFF	OFF	ON
$\phi 2$	OFF	ON	ON	ON	OFF	OFF	OFF	OFF
$\phi 3$	OFF	OFF	OFF	ON	ON	ON	OFF	OFF
$\phi 4$	OFF	OFF	OFF	OFF	OFF	ON	ON	ON

Output pulses change in the following orders when the Valve is open; 1 → 2 → 3 → 4 → 5 → 6 → 7 → 8  
 Valve is closed; 8 → 7 → 6 → 5 → 4 → 3 → 2 → 1

- \*1. When the LEV opening angle does not change, all the output phases will be off.
- \*2. When the output is open phase or remains ON, the motor cannot run smoothly, and rattles and vibrates.

### 3) LEV valve closing and opening operation

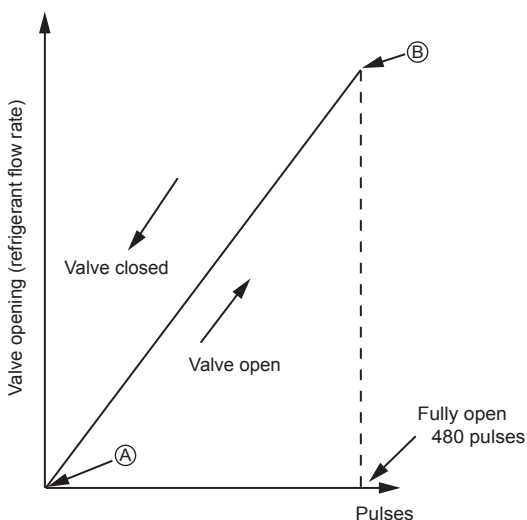

\*Upon power on, a 520 pulse signal is sent to the LEV to determine the valve position and bring the valve to the position indicated by "A" in the diagram. (Pulse signal is output for approximately 17 seconds.)

The LEV is free of noise and vibration when it is functioning properly, but it makes a noise when it becomes locked.

\*Whether a sound is generated or not can be determined by holding a screwdriver against it, then placing your ear against the handle.

\*If liquid refrigerant is present in the LEV, it may make the operating sound of the LEV difficult to detect.

**(1) Judgment methods and possible failure mode**

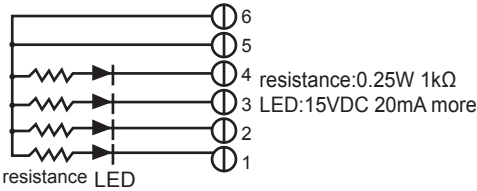
Malfunction mode		Judgment method	Remedy
Microcomputer driver circuit failure		<p>Disconnect the control board connector and connect the check LED as shown in the figure below.</p>  <p>Pulse signal is output for 17 seconds when the main power is turned on. If there is any LED that remains unlit or remains lit, there is a problem with the drive circuit.</p>	When the drive circuit has a problem, replace the control board.
LEV mechanism is locked		<p>If the LEV is locked, the drive motor runs idle, and makes a small clicking sound. When the valve makes a closing and opening sound, the valve has a problem.</p>	Replace the LEV.
Disconnected or short-circuited LEV motor coil	MAIN	<p>Measure resistance between the coils (red - white, red -orange, brown - yellow, brown - blue) using a tester. They are normal if resistance is <math>34.3\text{ohm} \pm 4.3\text{ohm}</math>.</p>	Replace the LEV coils.
	INJ	<p>Measure resistance between the coils (red - white, red -orange, brown - yellow, brown - blue) using a tester. They are normal if resistance is <math>46\text{ohm} \pm 3\text{ohm}</math>.</p>	Replace the LEV coils.
Faulty wire connections in the connector or faulty contact		<ol style="list-style-type: none"> <li>1. Check for loose pins on the connector and check the colors of the lead wires visually</li> <li>2. Disconnect the control board's connector and conduct a continuity check using a tester.</li> </ol>	Check the continuity at the points where an error occurs.

### 3. Injection LEV coil removal procedure

The LEV consists of a coil and a valve body that can be separated from each other.

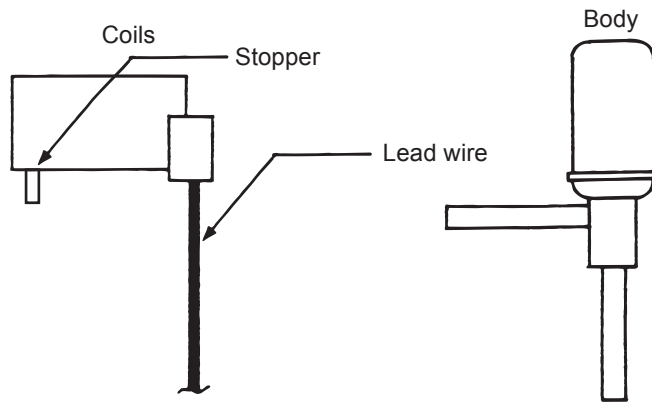

#### (1) Removing the coils

Fasten the body tightly at the bottom (Part A in the figure) so that the body will not move, then pull out the coils toward the top. If the coils are pulled out without the body gripped, undue force will be applied and the pipe will be bent.

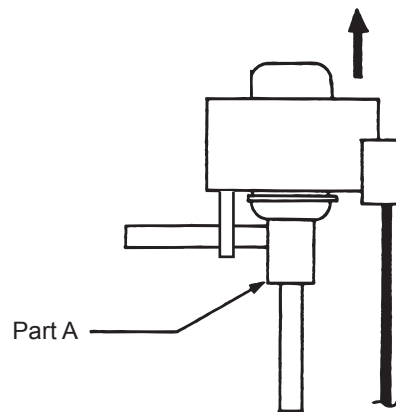

#### (2) Installing the coils

Fix the body tightly at the bottom (Part A in the figure) so that the body will not move, then insert the coils from the top, and insert the coil stopper securely in the pipe on the body. Hold the body when pulling out the coils to prevent so that the pipe will not be bent.

If the coils are pushed without the body gripped, undue force will be applied and the pipe will be bent. Hold the body when pulling out the coils to prevent so that the pipe will not be bent.

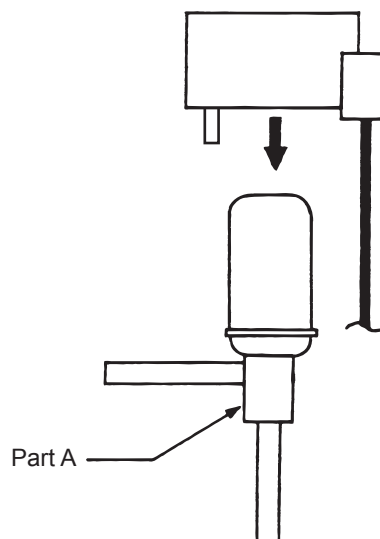

## -5- Inverter

- Replace only the compressor if only the compressor is found to be defective.
- Replace only the fan motor if only the fan motor is found to be defective.
- Replace the defective components if the inverter is found to be defective.
- If both the compressor and the inverter are found to be defective, replace the defective component(s) of both devices.

### (1) Inverter-related problems: Troubleshooting and remedies

- 1) The INV board has a large-capacity electrolytic capacitor, in which residual voltage remains even after the main power is turned off, posing a risk of electric shock. Before inspecting the inside of the control box, turn off the power, keep the unit off for at least 10 minutes, and confirm that the voltage between FT-P and FT-N on INV Board has dropped to DC20V or less. (It takes about 10 minutes to discharge electricity after the power supply is turn off.)
- 2) The IPM on the inverter becomes damaged if there are loose screws or connectors. If a problem occurs after replacing some of the parts, mixed up wiring is often the cause of the problem. Check for proper connection of the wiring, screws, connectors, and Faston terminals.
- 3) To avoid damage to the circuit board, do not connect or disconnect the inverter-related connectors with the main power turned on.
- 4) Faston terminals have a locking function. Make sure the terminals are securely locked in place after insertion.

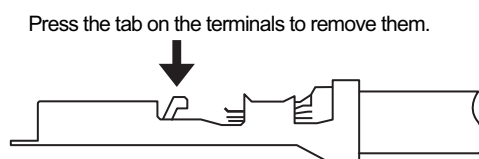

- 5) When the IPM or IGBT is replaced, apply a thin layer of heat radiation grease that is supplied evenly to these parts. Wipe off any grease that may get on the wiring terminal to avoid terminal contact failure.
- 6) Faulty wiring to the compressor damages the compressor. Connect the wiring in the correct phase sequence.

	Error display/failure condition	Measure/inspection item
[1]	Inverter related errors 4250, 4255, 4220, 4225, 4230, 4235, 4240, 4245, 5301, 5305, 5110, 0403, 4102, 4260, 4265	Check the details of the inverter error in the error log at [1] Error history item list. (page 122) Take appropriate measures to the error code and the error details in accordance with [2] 2.Diagnosing Problems Using Error Codes.(page 129)
[2]	Main power breaker trip	Refer to "(3) Trouble treatment when the main power breaker is tripped".(page 147)
[3]	Main power earth leakage breaker trip	Refer to "(4) Trouble treatment when the main power earth leakage breaker is tripped".(page 147)
[4]	Only the compressor does not operate.	Check the inverter frequency on the LED monitor and proceed to (2) - [4] if the compressor is in operation.(page 146)
[5]	The compressor vibrates violently at all times or makes an abnormal sound.	See (2)-[4].(page 146)
[6]	Only the fan motor does not operate.	Check the inverter frequency on the LED monitor and proceed to (2)-[6] if the fan motor is in operation.(page 146)
[7]	The fan motor shakes violently at all times or makes an abnormal sound.	Check the inverter frequency on the LED monitor and proceed to (2)-[6] if the fan motor is in operation.(page 146)
[8]	Noise is picked up by the peripheral device	<p>&lt;1&gt; Check that power supply wiring of the peripheral device does not run close to the power supply wiring of the outdoor unit.</p> <p>&lt;2&gt; Check if the inverter output wiring is not running parallel to the power supply wiring and the transmission lines.</p> <p>&lt;3&gt; Check that the shielded wire is used as the transmission line when it is required, and check that the grounding work is performed properly on the shielded wire.</p> <p>&lt;4&gt; Meg failure for electrical system other than the inverter</p> <p>&lt;5&gt; Attach a ferrite core to the inverter output wiring. (Contact the factory for details of the service part settings.)</p> <p>&lt;6&gt; Provide separate power supply to the air conditioner and other electric appliances.</p> <p>&lt;7&gt; If the error occurred suddenly, a ground fault of the inverter output can be considered. See (2)-[4].(page 146)</p> <p>*Contact the factory for cases other than those listed above.</p>
[9]	Sudden malfunction (as a result of external noise.)	<p>&lt;1&gt; Check that the grounding work is performed properly.</p> <p>&lt;2&gt;Check that the shielded wire is used as the transmission line when it is required, and check that the grounding work is performed properly on the shielded wire.</p> <p>&lt;3&gt;Check that neither the transmission line nor the external connection wiring does not run close to another power supply system or does not run through the same conduit pipe.</p> <p>* Contact the factory for cases other than those listed above.</p>

**(2) Inverter output related troubles**

	Items to be checked	Phenomena	Remedy
[1] Check the INV board error detection circuit.	(1) Disconnect the inverter output wire from the terminals of the INV board (SC-U, SC-V, SC-W).	1) Overcurrent error (4250 Detail code No. 102, 103, 106, and 107)	Replace the INV board.
	(2) Put the outdoor unit into operation.	2) Logic error (4220 Detail code No. 111)	Replace the INV board.
		3) ACCT sensor circuit failure (5301 Detail code No.117)	Replace the INV board.
		4) IPM open (5301 Detail code No.119)	Normal
[2] Check for compressor ground fault or coil error.	Disconnect the compressor wiring, and check the compressor Meg, and coil resistance.	1) Compressor Meg failure Error if less than 1 Mohm.	Check that there is no liquid refrigerant in the compressor. If there is none, replace the compressor.
		2) Compressor coil resistance failure Coil resistance value of 0.583 ohm (20°C)	Replace the compressor.
[3] Check whether the inverter is damaged. (No load)	(1) Disconnect the inverter output wire from the terminals of the INV board (SC-U, SC-V, SC-W).	1) Inverter-related problems are detected.	Connect the short-circuit connector to CN6, and go to section [1].
	(2) Disconnect the short-circuit connector from CN6 on the INV board.	2) Inverter voltage is not output at the terminals (SC-U, SC-V, and SC-W)	Replace the INV board.
	(3) Put the outdoor unit into operation. Check the inverter output voltage after the inverter output frequency has stabilized.	3) There is a voltage imbalance between the wires. Greater than 5% imbalance or 5V	Replace the INV board.
		4) There is no voltage imbalance between the wires.	Normal *Reconnect the short-circuit connector to CN6 after checking the voltage.



	Items to be checked	Phenomena	Remedy
[4] Check whether the inverter is damaged. (During compressor operation)	Put the outdoor unit into operation. Check the inverter output voltage after the inverter output frequency has stabilized.	1) Overcurrent-related problems occur immediately after compressor startup. Error code : 4250 Detail code : 102, 103, 106, 107	a. Check items [1] through [3] for problems. b. Check that high and low pressures are balanced. c. Check that no liquid refrigerant is present in the compressor. →Go to "d." when the problem persists after compressor startup was repeated several times. If normal operation is restored, check the crankcase heater for problems. d. Check that there is a pressure difference between high and low pressures after compressor startup. →Check the high pressure with LED monitor for changes. Replace the compressor if there is no pressure difference. (the compressor may be locked.)
		2) There is a voltage imbalance between the wires after the inverter output voltage is stabilized. Greater than the larger of the following values: imbalance of 5% or 5V	Replace the INV board if there is a voltage imbalance. Check the crankcase heater for problems if there is no voltage imbalance. →When the error occurred, liquid refrigerant may have been present in the compressor.
[5] Check the fan motor ground fault or the winding.	Remove the wire for the outdoor fan motor, and check the fan motor megger and the winding resistance.	1) Fan motor megger failure Failure when the megger is 1Mohm or less.	Replace the fan motor.
		2) Fan motor disconnection Standard: The winding resistance is approximately several ohm. (It varies depending on the temperature, or while the inner thermo is operating, it will be ∞ ohm)	
[6] Check the fan inverter board failure.	(1) Check the fan output wiring.	Connector contact failure ♦Board side (CNINV) ♦Fan motor side	Connect the connector.
	(2) Check the connector CN-VDC connection.	Cnconnector contact failure	Connect the connector.
	(3) Check the FAN board failure.	1) The voltage imbalance among each motor wiring during operation (The voltage imbalance is greater than the larger of the values represented by 5% or 5V.)	2) The same error occurs even after the operation is restarted.

**(3) Trouble treatment when the main power breaker is tripped**

	Items to be checked	Phenomena	Remedy
[1]	Check the breaker capacity.	Use of a non-specified breaker	Replace it with a specified breaker.
[2]	Perform Meg check between the terminals on the power terminal block TB4.	Zero to several ohm, or Meg failure	Check each part and wiring. *Refer to (5) "Simple checking procedure for individual components of main inverter circuit".(page 148) ♦IGBT module ♦Rush current protection resistor ♦Electromagnetic relay ♦DC reactor
[3]	Turn on the power again and check again.	1) Main power breaker trip 2) No remote control display	
[4]	Turn on the outdoor unit and check that it operates normally.	1) Operates normally without tripping the main breaker. 2) Main power breaker trip	a) The wiring may have been short-circuited. Search for the wire that short-circuited, and repair it. b) If item a) above is not the cause of the problem, refer to (2)-[1]-[6].(page 145)

**(4) Trouble treatment when the main power earth leakage breaker is tripped**

	Items to be checked	Phenomena	Remedy
[1]	Check the earth leakage breaker capacity and the sensitivity current.	Use of a non-specified earth leakage breaker	Replace with a regulation earth leakage breaker.
[2]	Check the resistance at the power supply terminal block with a megger.	Failure resistance value	Check each part and wiring. *Refer to (5) "Simple checking procedure for individual components of main inverter circuit".(page 148) ♦IGBT module ♦Rush current protection resistor ♦Electromagnetic relay ♦DC reactor
[3]	Disconnect the compressor wirings and check the resistance of the compressor with a megger.	Failure compressor if the insulating resistance value is not in specified range. Failure when the insulating resistance value is 1 Mohm or less.	Check that there is no liquid refrigerant in the compressor. If there is none, replace the compressor.
[4]	Disconnect the fan motor wirings and check the resistance of the fan motor with a megger.	Failure fan motor if the insulating resistance value is not in specified range. Failure when the insulating resistance value is 1 Mohm or less.	Replace the fan motor.

**Note**

The insulation resistance could go down to close to 1Mohm after installation or when the power is kept off for an extended period of time because of the accumulation of refrigerant in the compressor. If the earth leakage breaker is triggered, please use the following procedure to take care of this.

- ♦Disconnect the wires from the compressor's terminal block.
- ♦If the resistance is less than 1 Mohm, switch on the power for the outdoor unit with the wires still disconnected.
- ♦Leave the power on for at least 12 hours.
- ♦Check that the resistance has recovered to 1 Mohm or greater.

**Earth leakage current measurement method**

- ♦For easy on-site measurement of the earth leakage current, enable the filter with a measurement instrument that has filter functions as below, clamp all the power supply wires, and measure.  
Recommended measurement instrument: CLAMP ON LEAK HiTESTER 3283 made by HIOKI E.E. CORPORATION
- ♦When measuring one device alone, measure near the device's power supply terminal block.

**(5) Simple checking procedure for individual components of main inverter circuit**

**Note**

Before inspecting the inside of the control box, turn off the power, keep the unit off for at least 10 minutes, and confirm that the voltage between FT-P and FT-N on INV Board has dropped to DC20V or less.

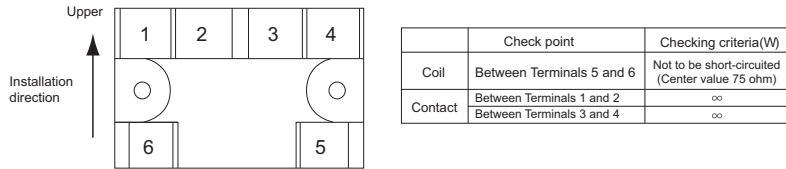
Part name	Judgment method											
IGBT module	See "Troubleshooting for IGBT Module ". ( IX [3] -5- (6) )(page 148)											
Rush current protection resistor R1, R5	Measure the resistance between terminals R1 and R5: 22 ohm $\pm$ 10%											
Electromagnetic relay 72C	<p><b>Note</b> This electromagnetic relay is rated at DC12V and is driven by a coil. Check the resistance between terminals</p>  <p>The diagram shows a relay with terminals 1, 2, 3, 4 in a top row and 6, 5 in a bottom row. Terminals 1 and 2 are connected to a coil, and terminals 3 and 4 are connected to a contact. Terminals 5 and 6 are also connected to a coil. An arrow labeled 'Installation direction' points upwards. To the right is a table:</p> <table border="1"> <thead> <tr> <th></th> <th>Check point</th> <th>Checking criteria(W)</th> </tr> </thead> <tbody> <tr> <td>Coil</td> <td>Between Terminals 5 and 6</td> <td>Not to be short-circuited (Center value 75 ohm)</td> </tr> <tr> <td rowspan="2">Contact</td> <td>Between Terminals 1 and 2</td> <td><math>\infty</math></td> </tr> <tr> <td>Between Terminals 3 and 4</td> <td><math>\infty</math></td> </tr> </tbody> </table>		Check point	Checking criteria(W)	Coil	Between Terminals 5 and 6	Not to be short-circuited (Center value 75 ohm)	Contact	Between Terminals 1 and 2	$\infty$	Between Terminals 3 and 4	$\infty$
	Check point	Checking criteria(W)										
Coil	Between Terminals 5 and 6	Not to be short-circuited (Center value 75 ohm)										
Contact	Between Terminals 1 and 2	$\infty$										
	Between Terminals 3 and 4	$\infty$										
DC reactor DCL	Measure the resistance between terminals: 1ohm or lower (almost 0 ohm) Measure the resistance between terminals and the chassis: $\infty$											

**(6) Troubleshooting for IGBT Module**

Measure the resistances between each pair of terminals on the IGBT with a tester, and use the results for troubleshooting. The terminals on the INV board are used for the measurement.

1) Notes on measurement

- Check the polarity before measuring. (On the tester, black normally indicates plus.)
- Check that the resistance is not open ( $\infty$  ohm) or not shorted (to 0 ohm).
- The values are for reference, and the margin of errors is allowed.
- The result that is more than double or half of the result that is measured at the same measurement point is not allowed.
- Disconnect all the wiring connected the INV board, and make the measurement.

2) Tester restriction

- Use the tester whose internal electrical power source is 1.5V or greater
- Use the dry-battery-powered tester.

**Note**

(The accurate diode-specific resistance cannot be measured with the button-battery-powered card tester, as the applied voltage is low.)

- Use a low-range tester if possible. A more accurate resistance can be measured.

Judgment value (reference)

		Black (+)				
		SC-P1	FT-N	SC-L1	SC-L2	SC-L3
Red (-)	SC-P1	-	-	5 - 200 ohm	5 - 200 ohm	5 - 200 ohm
	FT-N	-	-	∞	∞	∞
	SC-L1	∞	5 - 200 ohm	-	-	-
	SC-L2	∞	5 - 200 ohm	-	-	-
	SC-L3	∞	5 - 200 ohm	-	-	-

		Black (+)				
		SC-P2	FT-N	SC-U	SC-V	SC-W
Red (-)	SC-P2	-	-	5 - 200 ohm	5 - 200 ohm	5 - 200 ohm
	FT-N	-	-	∞	∞	∞
	SC-U	∞	5 - 200 ohm	-	-	-
	SC-V	∞	5 - 200 ohm	-	-	-
	SC-W	∞	5 - 200 ohm	-	-	-

INV board external diagram

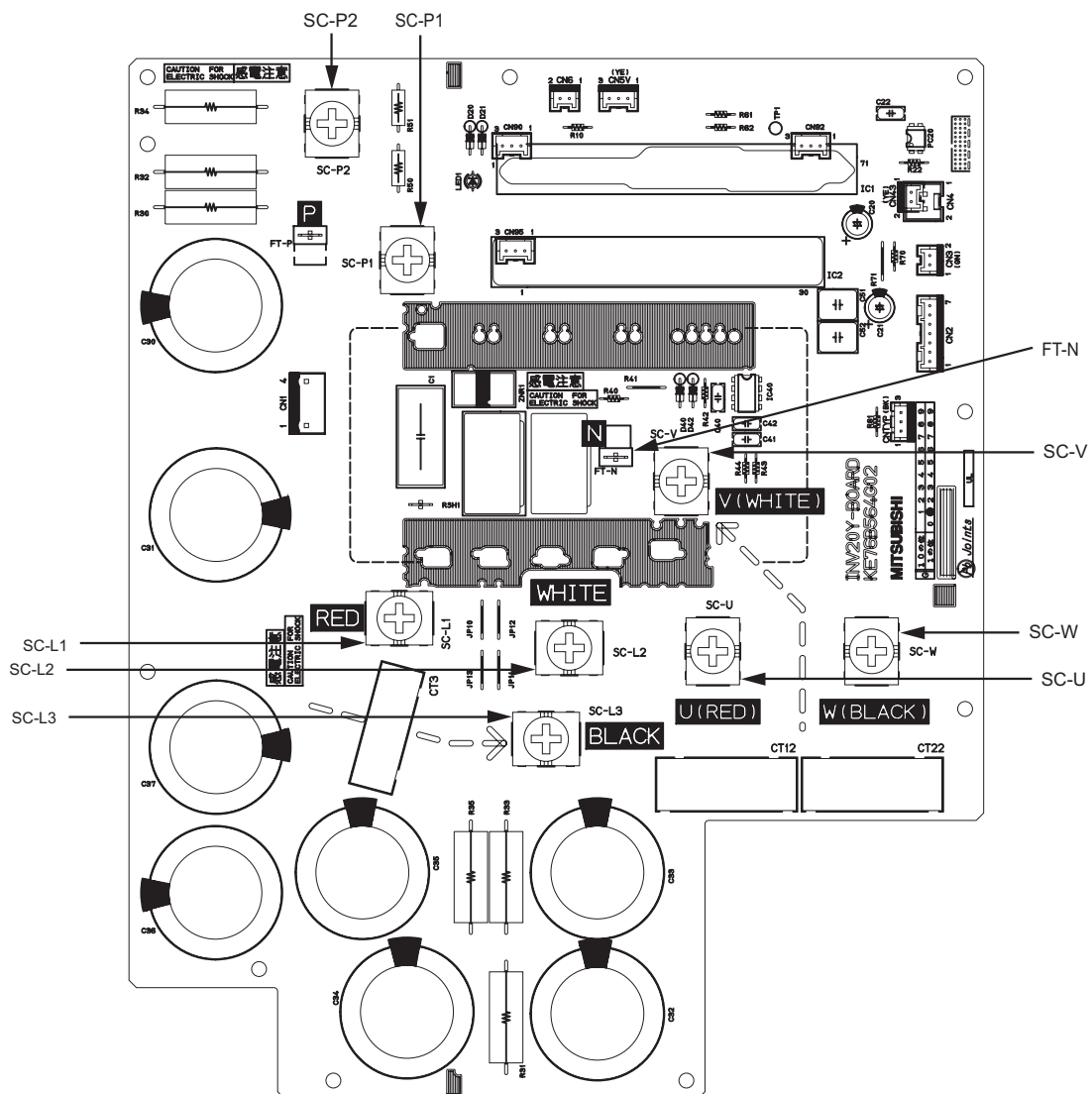

**-6- Control Circuit**

**Troubleshooting transmission power circuit of outdoor unit**

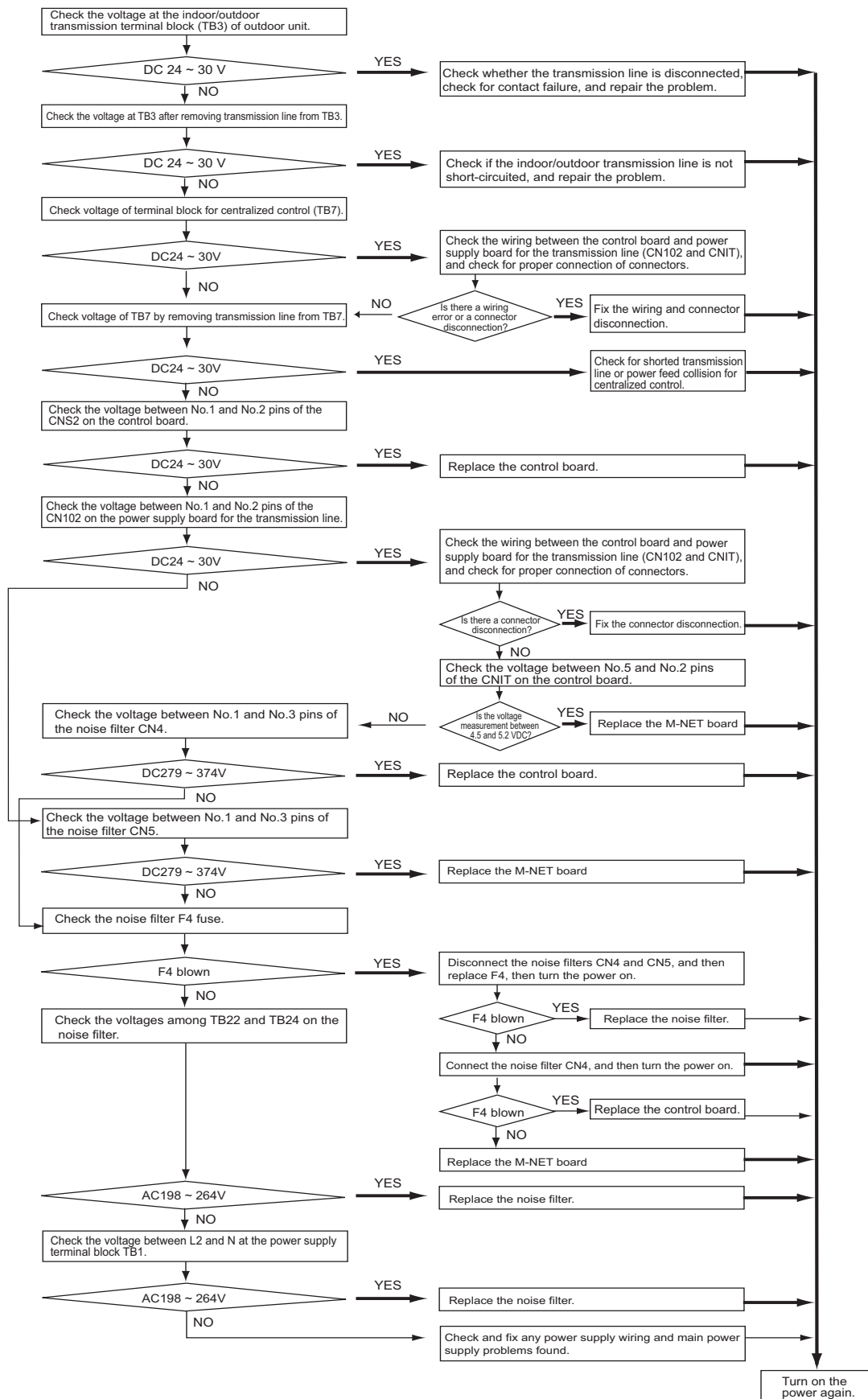

## **-7- Troubleshooting**

### **1. Important notes**

If the unit or its refrigerant circuit components experience malfunctions, take the following steps to prevent recurrence.

- (1) Diagnose the problem and find the cause.
- (2) Before repairing leaks on the brazed sections on the pipes, recover the refrigerant. Braze under nitrogen purge to prevent oxidation.
- (3) If any component (including the compressor) malfunctions, only replace the affected parts; it is not necessary to replace the entire unit.
- (4) Be sure to recover the refrigerant from the unit before disposing of the unit.
- (5) If the cause of the problem cannot be identified, contact the service desk with the following information: unit model, serial number, and the nature of the problem.

### **2. Before replacing the fan**

- (1) Before replacing the fan, turn off the main power of the unit.
- (2) The motor connectors are on the FAN INV board in the control box and can be accessed by removing the service panel and the fan guard.
- (3) Install the fan wires as they were, using the same route and all required clamps.

## [4] Refrigerant Leak

---

### WARNING

**Do not use refrigerant other than the type indicated in the manuals provided with the unit and on the nameplate.**

- Doing so may cause the unit or pipes to burst, or result in explosion or fire during use, during repair, or at the time of disposal of the unit.
- It may also be in violation of applicable laws.
- MITSUBISHI ELECTRIC CORPORATION cannot be held responsible for malfunctions or accidents resulting from the use of the wrong type of refrigerant.

#### **1. Leak spot: In the case of outdoor unit**

- 1) Collect the refrigerant in the entire system (outdoor unit). Do not discharge refrigerant into the atmosphere when it is collected.
- 2) Repair the leak.
- 3) Repair the leak, and evacuate the air from the entire system <sup>\*1</sup>.  
Charge the system with  $6.5 \pm 0.3$  kg of R744.

\*1. Refer to Chapter I [4] (4) Vacuuming the refrigerant circuit for detailed procedure.(page 9)

**[5] Parts Replacement Procedures**

Replacement instructions for the gas cooler [QAHV-N560YA-HPB]

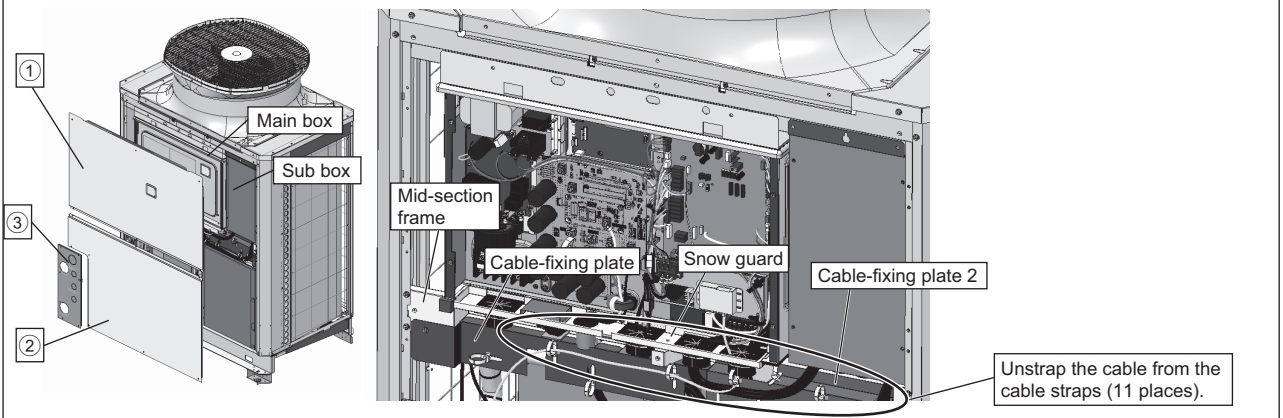
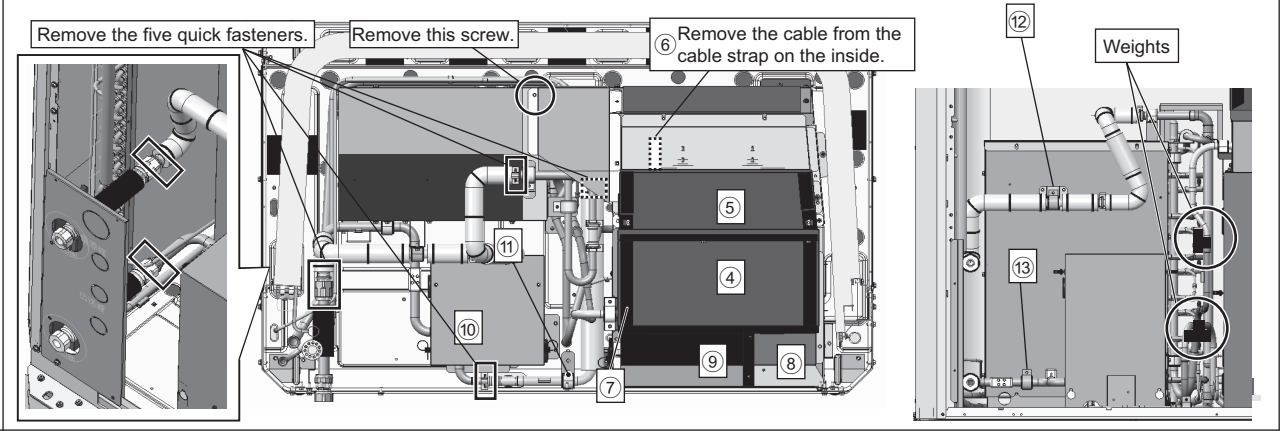
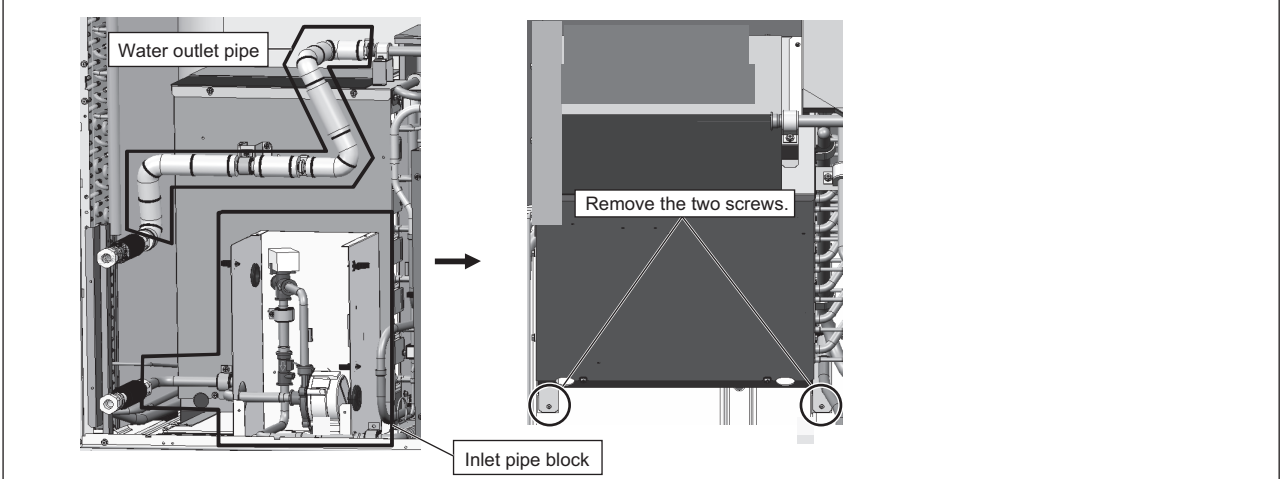
Step No.	Procedure
1	<p>Remove the front panels ①, ②, and ③ from the unit (① 6 screws, ② 5 screws, ③ 3 screws).                      Remove the main box cover (4 screws).                      Remove the snow guard (1 screw) and the cable fixing plates 1 and 2 (2 screws each).                      Remove the main box (2 screws), sub box (3 screws), and then the mid-section frame (4 screws).                      *Use a magnetic screwdriver to keep the removed screws from being dropped into the mechanical section of the unit.</p> 
2	<p>Remove the following parts: screws, quick fasteners, sheet metals, and weights.                      (④ 2 screws, ⑤ 2 screws, ⑥ 4 screws, ⑦ 6 screws (4 on sheet metal and 2 on saddle), ⑧ 3 screws, ⑨ 1 screw, ⑩ 4 screws, ⑪ 2 screws (1 on the sheet metal and 1 on the saddle), ⑫ and ⑬ 1 on each saddle)</p> 
3	<p>Remove the water outlet pipe/inlet pipe block (12 screws and 6 quick fasteners), and unscrew the two fixing screws on the gas cooler.</p> 





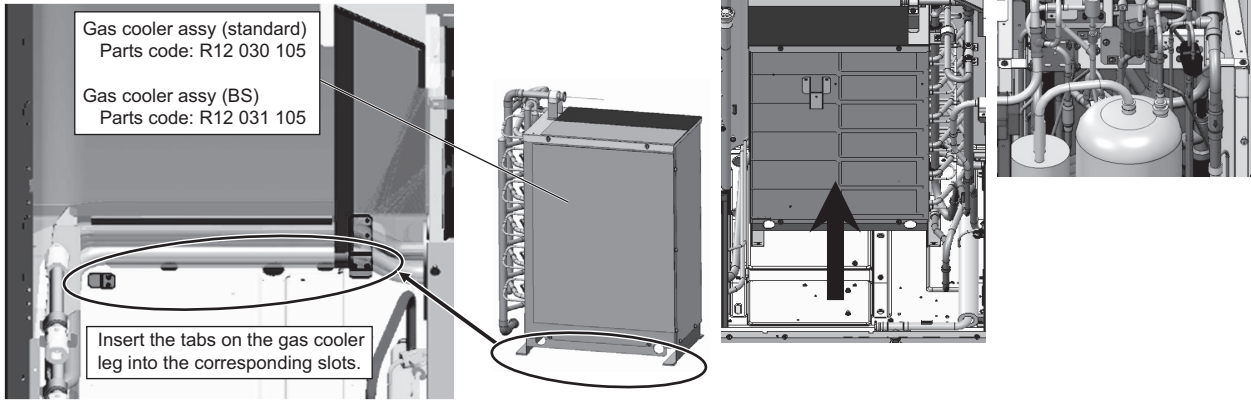
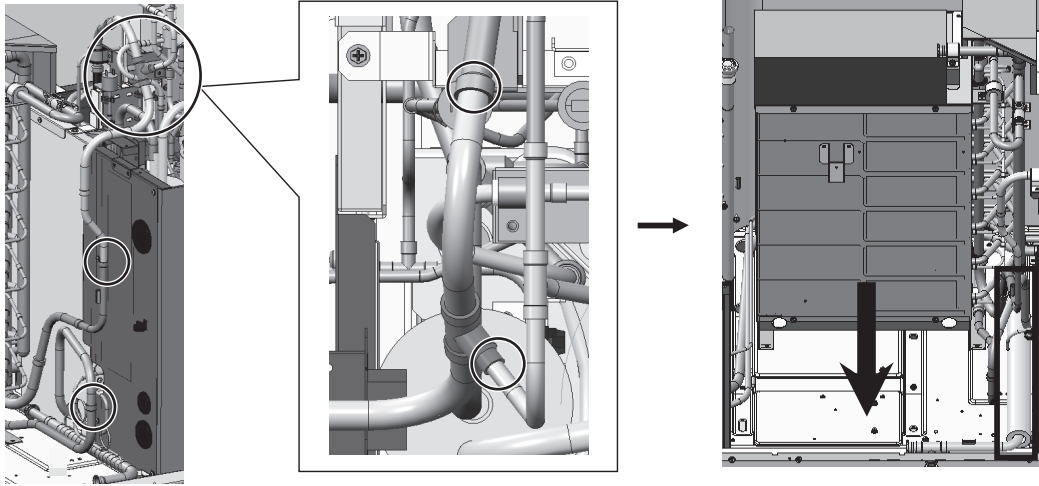

Replacement instructions for the gas cooler [QAHV-N560YA-HPB]







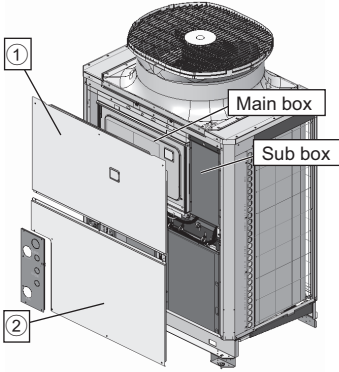
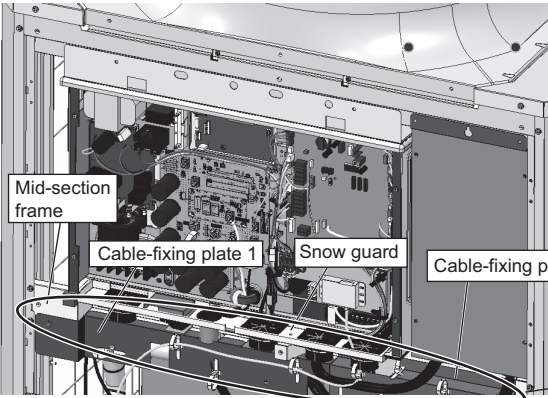
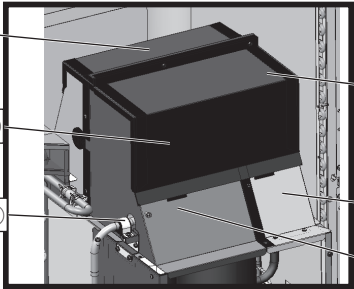
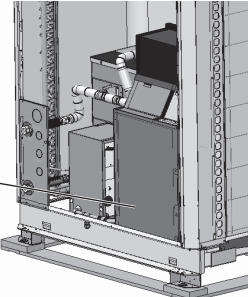
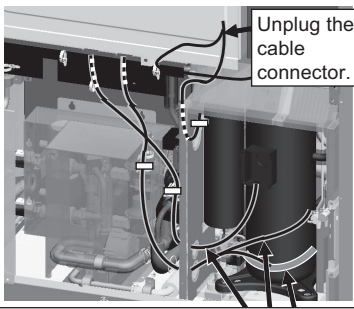
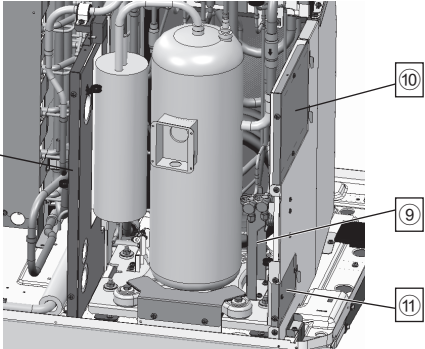

Step No.	Procedure
4	<p>Remove the pipes from the four sections encircled in the figure below (refer to the replacement procedures for refrigerant circuit components), pull out the pipes indicated by the black rectangle in the figure below, and pull the gas cooler forward.</p>
5	<p>Install the gas cooler, braze the pipes, and re-place all parts that were removed in the steps above.</p>

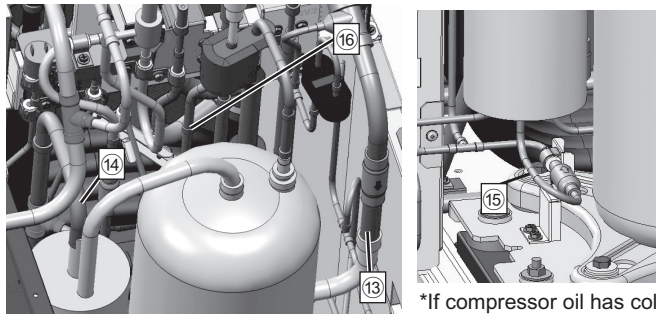
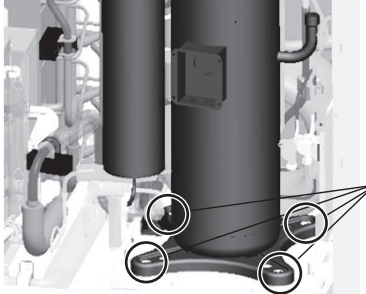

Replacement instructions for the compressor [QAHV-N560YA-HPB]

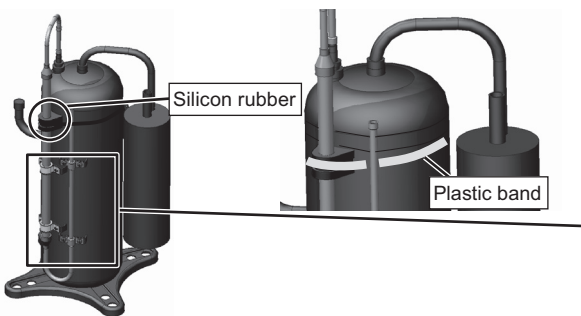
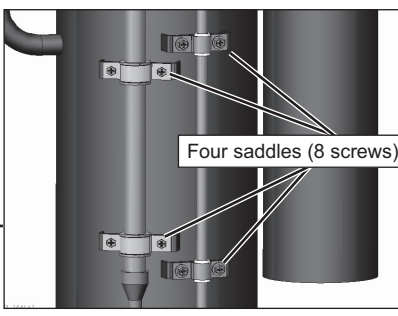
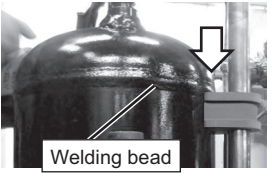
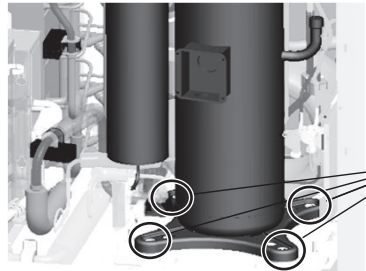
Step No.	Procedure
1	<p>[Parts preparation] Each unit requires the following parts.</p> <div style="display: flex; justify-content: space-between; align-items: flex-start;"> <div style="text-align: center;">  <p>⑰ Scroll compressor Parts code: R69 143 478</p> </div> <div style="text-align: center;">  <p>Plastic band Parts code: R15 001 843</p> </div> <div style="text-align: center;">  <p>⑬ Compressor suction pipe Parts code: R12 006 011</p> </div> <div style="text-align: center;">  <p>⑭ Compressor discharge pipe Parts code: R12 008 011</p> </div> </div>
2	<p>Remove the front panels ① and ② [① 6 screws , ② 5 screws], the main box cover [4 screws], and the snow guard [1 screw]. Then, remove the cable fixing plates 1 and 2 [2 screws each]. Remove the main box [2 screws], sub box [3 screws], and then remove the mid-section frame [4 screws].</p> <p>*Use a magnetic screwdriver to keep the removed screws from being dropped into the mechanical section of the unit.</p> <div style="display: flex; justify-content: space-around;"> <div style="text-align: center;">  <p>① Main box Sub box ②</p> </div> <div style="text-align: center;">  <p>Mid-section frame Cable-fixing plate 1 Snow guard Cable-fixing plate 2</p> </div> </div> <p style="text-align: right;">Unstrap the cable from the cable straps (11 places).</p>
3	<p>Remove the following sheet metals [③ 2 screws, ④ 2 screws, ⑤ 6 screws (4 on sheet metal and 2 on saddle), ⑥ 3 screws, ⑦ 1 screw, ⑧ 4 screws].</p> <div style="display: flex; justify-content: space-around;"> <div style="text-align: center;">  <p>④ ③ ⑤</p> </div> <div style="text-align: center;">  <p>⑥ ⑧ ⑥ ⑦</p> </div> </div>
4	<p>Remove the following sheet metals [⑨ 4 screws, ⑩ 2 screws, ⑪ 2 screws, ⑫ 1 screw].</p> <div style="display: flex;"> <div style="flex: 1;"> <p>⑫ Disconnect the wires first, and then remove the sheet metals.</p> <div style="border: 1px solid black; padding: 5px; margin-bottom: 5px;"> <p>Unplug the cable connector.</p>  </div> <div style="border: 1px solid black; padding: 5px;"> <p>Disconnect the power wire, the crankcase heater wire, and the ground wire.</p> </div> </div> <div style="flex: 1; text-align: center;">  <p>⑩ ⑨ ⑪</p> </div> </div>

Replacement instructions for the compressor [QAHV-N560YA-HPB]

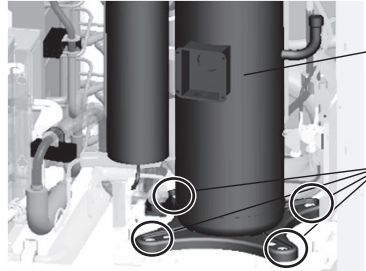
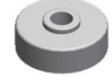
Step No.	Procedure	
5	<p>Remove the pipes ⑬, ⑭, ⑮, and ⑯ from the compressor. (Refer to the replacement procedures for refrigerant circuit components.)</p>  <p>*If compressor oil has collected at the bottom, use caution not to let its heat damage the surrounding components.</p>	<p>Remove the compressor by removing the compressor fixing fittings with a spanner.</p>  <div data-bbox="1260 324 1460 616"> <p>Compressor fixing fittings (4 sets)</p> <ul style="list-style-type: none"> <li> Bolt M8X50</li> <li> Washer ø26</li> <li> Rubber washer</li> <li> Spacer</li> </ul> </div>
6	<p>Cut the plastic bands. Remove the pipes, saddles, silicon rubber, and sheet metals from the back of the compressor (8 screws), and attach them to the replacement compressor.</p> 	 <p>Bring the top of the silicon rubber flush with the bottom of the compressor welding bead.</p> 
7	<p>Install the vibration isolation rubbers to the compressor legs, and install the compressor ⑰.</p>  <div data-bbox="630 1209 877 1478"> <p>Compressor fixing fittings (4 sets)</p> <ul style="list-style-type: none"> <li> Bolt M8X50</li> <li> Washer ø26</li> <li> Rubber washer</li> <li> Spacer</li> </ul> </div>	 <div data-bbox="1292 1332 1460 1500"> <p> Vibration isolation rubber (4 pieces)</p> </div> <p>Replace the compressor fixing fittings, braze the pipes, reinstall the sheet metals, and reconnect all wires back to the original condition.</p>

Replacement instructions for the solenoid valves and LEVs [QAHV-N560YA-HPB]

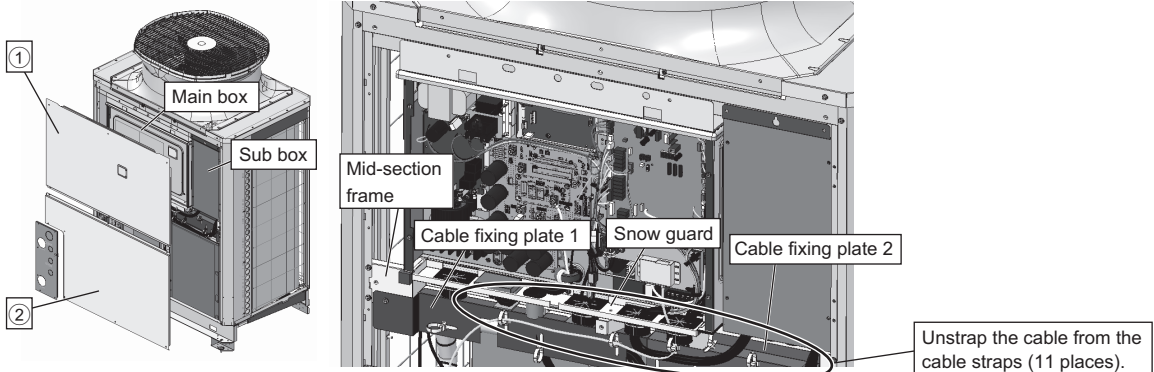
Step No.	Procedure
1	<p>Remove the front panels ① and ② [① 6 screws, ② 5 screws], the main box cover [4 screws], and the snow guard [1 screw]. Then, remove the cable fixing plates 1 and 2 [2 screws each]. Remove the main box [2 screws], sub box [3 screws], and then remove the mid-section frame [4 screws].                      *Use a magnetic screwdriver to keep the removed screws from being dropped into the mechanical section of the unit.</p> 

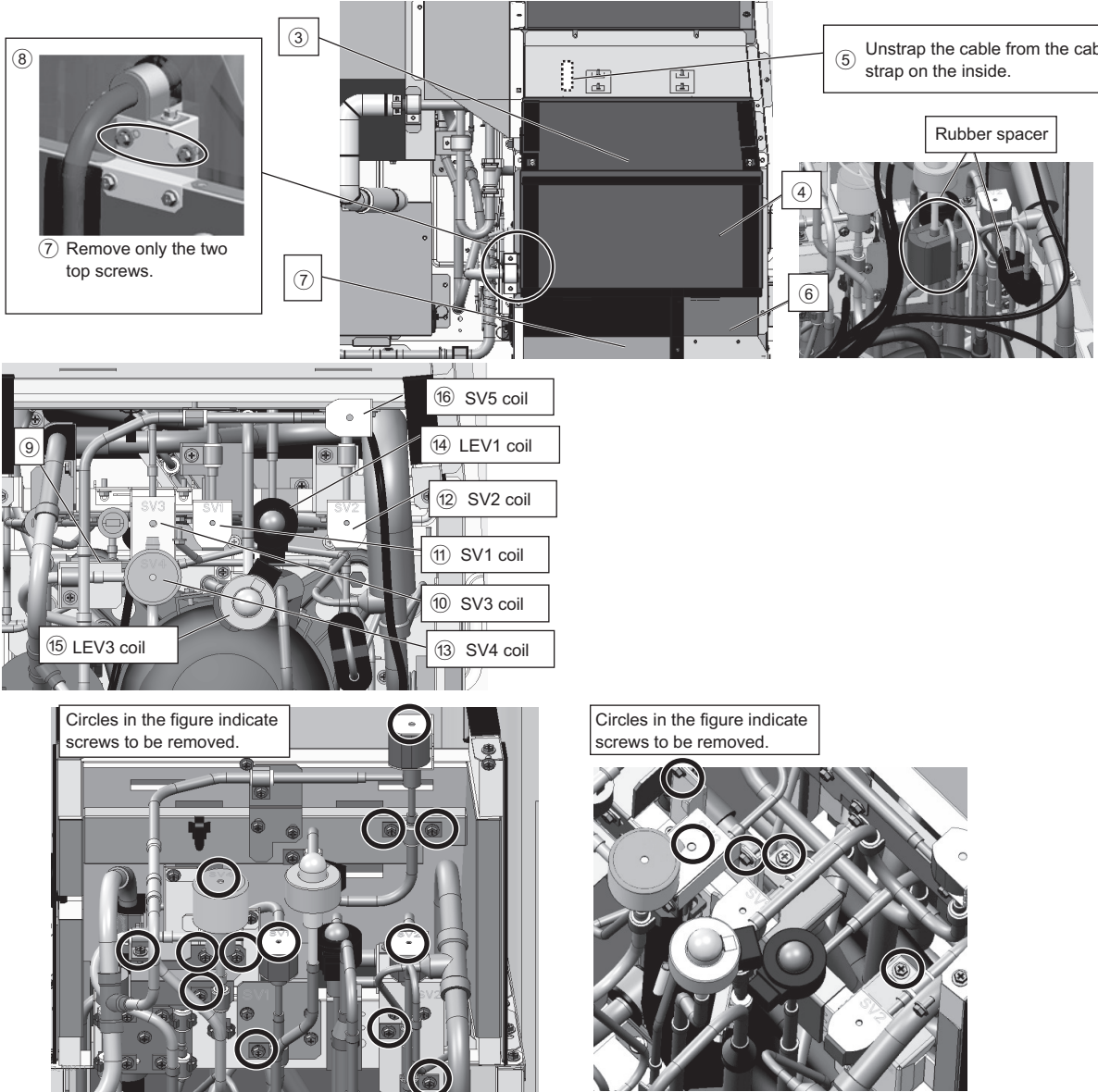
2	<p>Remove the following rubber spacers, sheet metals, and coils.                      [Number of screws ③ 2, ④ 2, ⑥ 3, ⑦ 1, ⑧ 2, ⑨ 4, ⑩ 3, ⑪ 3, ⑫ 3, ⑬ 1, ⑯ 3]                      Collect refrigerant in accordance with the instructions provided in "Replacement procedures for refrigerant circuit components."</p> 
---	--

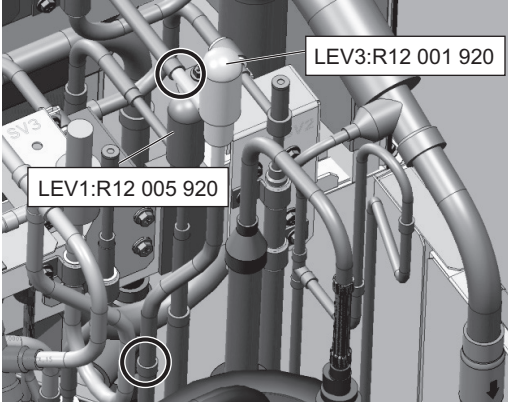
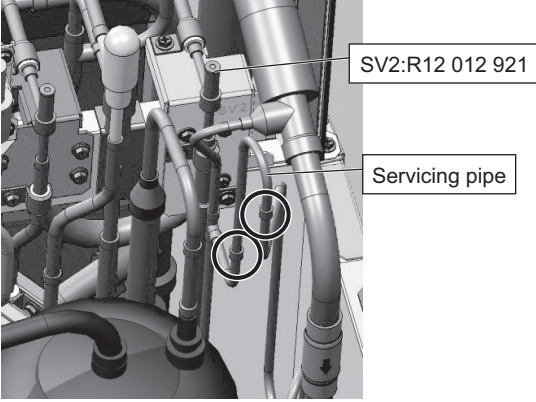
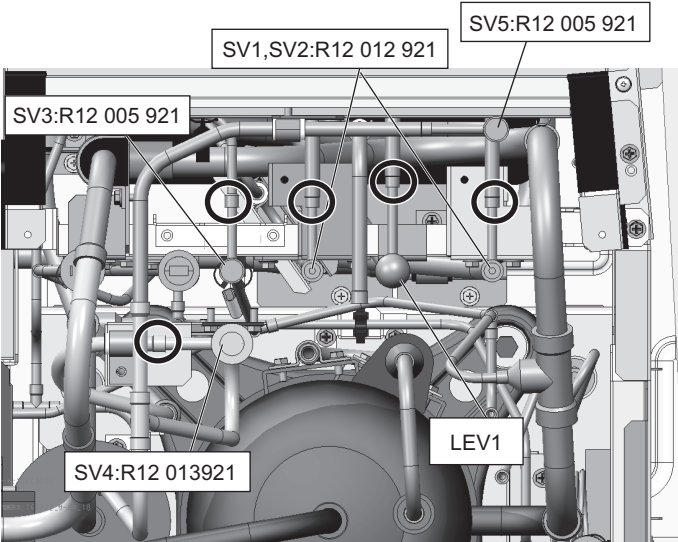
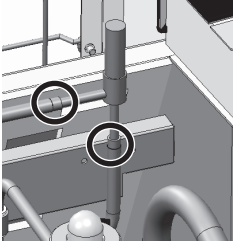
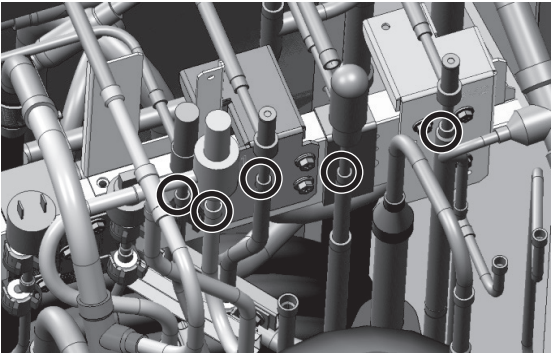

Replacement instructions for the solenoid valves and LEVs [QAHV-N560YA-HPB]

Step No.	Procedure
3	<p>To replace LEV1, remove LEV3 by debrazing the areas encircled in the figure below.                      To replace SV2, remove the servicing pipe by debrazing the areas encircled in the figure below.                      Cover the LEV and the surrounding sheet metals with a wet cloth to protect them from the torch flame.</p> <div style="display: flex; justify-content: space-around;"> <div style="text-align: center;"> <p>&lt;LEV1 replacement&gt;</p>  </div> <div style="text-align: center;"> <p>&lt;SV2 replacement&gt;</p>  </div> </div>
4	<p>Debrazed the areas encircled in the figure below to remove the solenoid valves and LEVs. Replace them with new ones.</p> <div style="display: flex;"> <div style="flex: 1;">  </div> <div style="flex: 1;">   </div> </div> <p>After replacing the solenoid valves and LEVs, re-place the coil and sheet metals, and reconnect wires back to the original condition.</p>

**[6] Removing scale from the gas cooler**

**1. General workflow: From determining the need for cleaning up to the completion of cleaning**

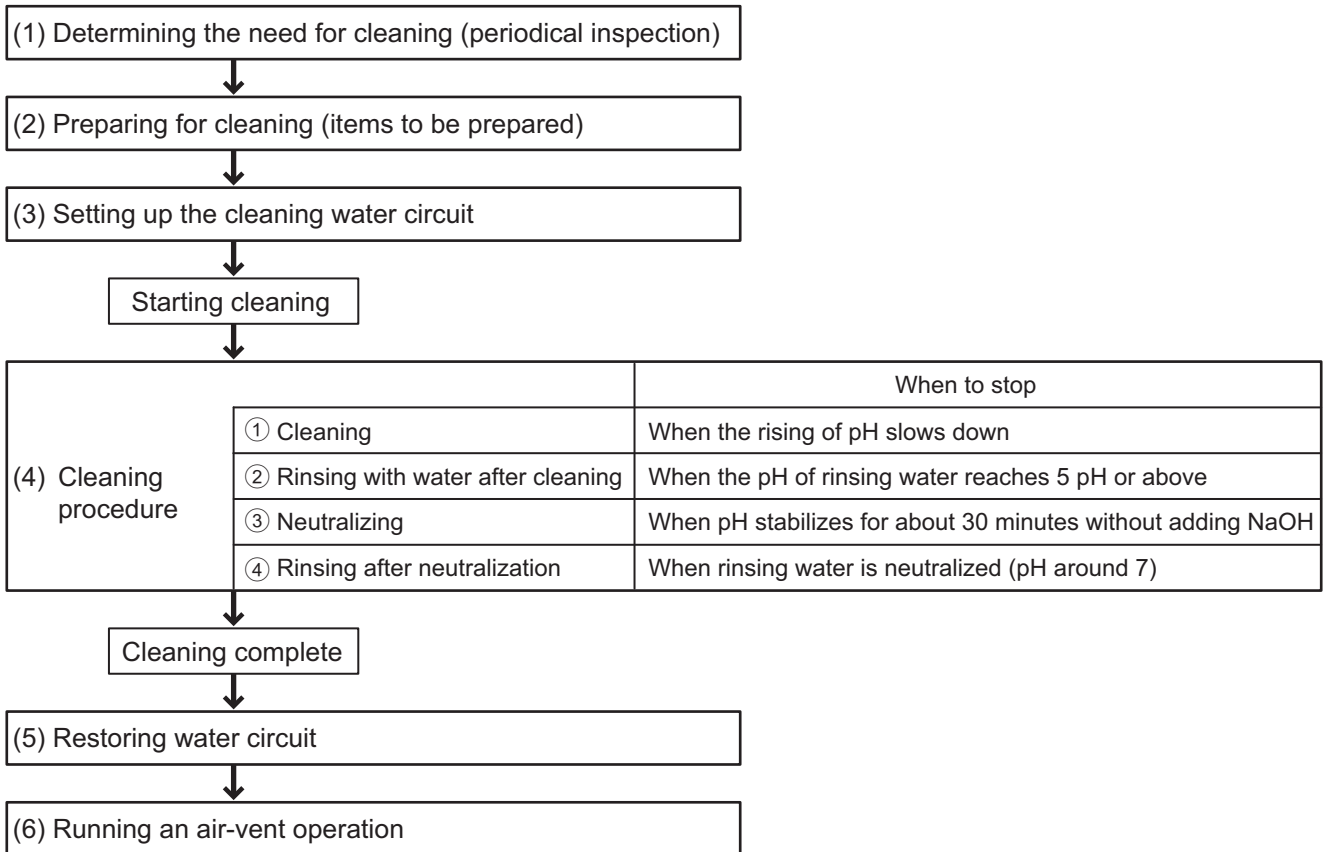

## 2. Detailed workflow: From determining the need for cleaning up to the completion of cleaning

Explained below are details of steps (1) through (6) in the previous page.

### (1) Determining the need for cleaning

\*Removal procedure for short pipe for checking the presence of scale

1) Shut off the power to the unit, close the valves at the hot water supply port, feed water port, and circulation water inlet before proceeding to the next step. (See the outline diagram for the location of pipe connections.)

2) The short pipe for checking the presence of scale can be found (see Photo 1) when seen from below the panel side of the machine room. (The short pipe is gold and is located behind the compressor.)

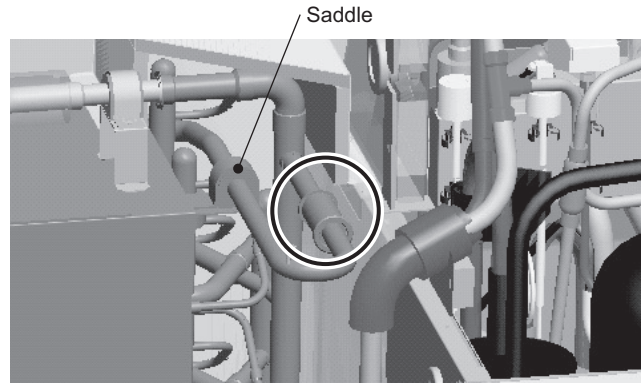

Photo 1: Location of the short pipe for checking the presence of scale

3) The short pipe is installed as shown in Photo 2. It can be disassembled into three components: ① Short pipe, ② fastener, and ③ gas cooler pipe.

To remove these components, first remove the saddle shown in Photo 1 from the top, pull up and out the fasteners ②, and then remove the gas cooler pipes ③ that are connected to the short pipe ①.

If the thickness of scale on the short pipe on the entire surface has exceeded 0.5 mm, perform cleaning.

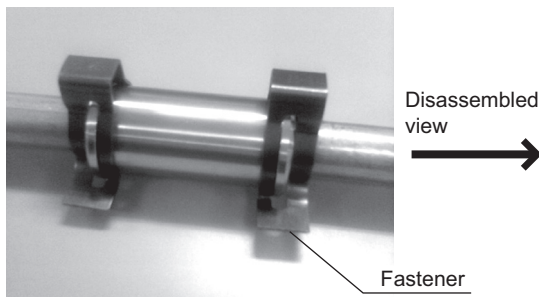

Photo 2: Short pipe for checking the presence of scale

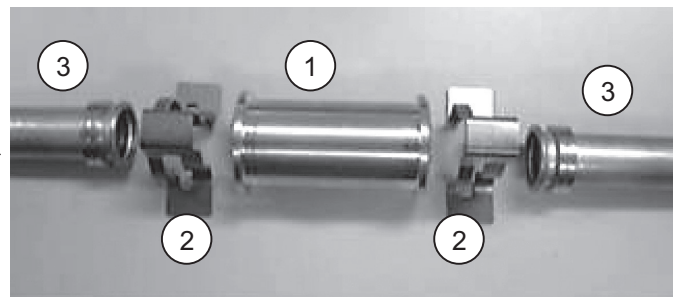

Photo 3: Disassembled view of the short pipe for checking the presence of scale

### (2) Preparation for cleaning

Items to prepare (Inside the dashed lines in Figure 1 is the cleaning device.)

- Cleaning agent
- Sodium nitrate (neutralizing agent)
- The use of solution type sodium nitrate is preferable. When using the powder type, powder must be well dissolved.
- ① Container (for cleaning)
- Approximate holding capacity (three to four times the internal volume of the circuit)
- ② Pump (15 L/min; water head: 3 m minimum)
- ③ Submersible pump (placed in the container for exhaust water)
- ④ Container for placing exhaust water (Approximate holding capacity: 100 L)
- pH tester
- Water pressure gauge (to measure approximate flow rate), if available
- Water

\*Internal gas cooler volume (the parts to be cleaned of scale):  
Approximately 7 L

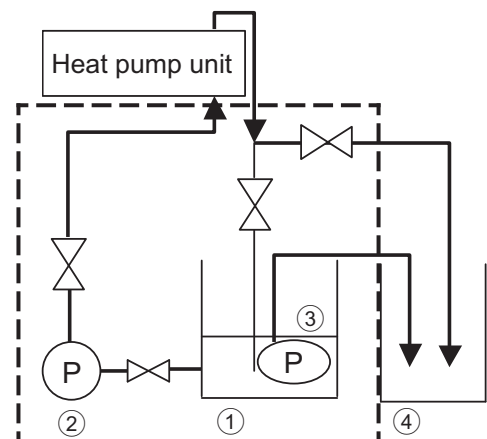

Figure 1 Cleaning device (inside the dashed lines)

**(3) Setting up the cleaning water circuit**

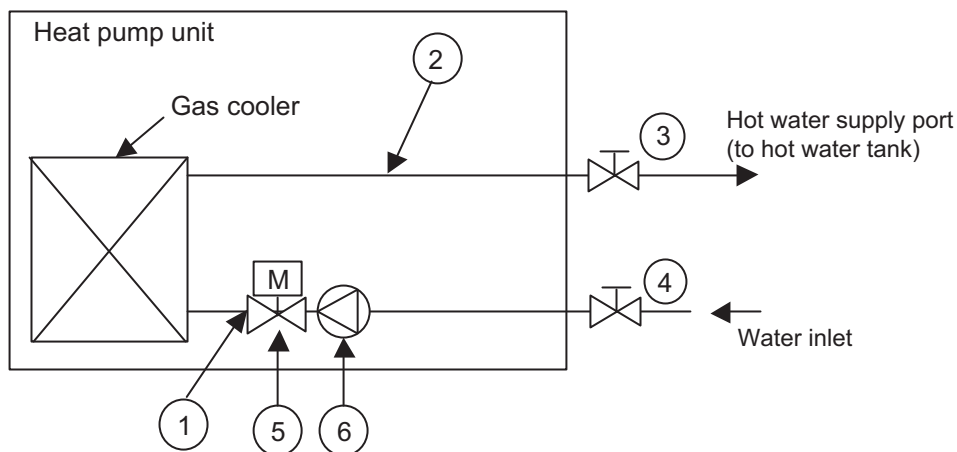

Figure 2: Valves to be closed and connections of cleaning water circuit

Figure 2 symbol explanation

- |   |  |                          |
|---|--|--------------------------|
| ① Connection to cleaning water circuit outlet | ② Connection to cleaning water circuit inlet | ③ Hot water supply valve |
| ④ Water inlet valve                           | ⑤ Flow rate control valve                    | ⑥ Pump                   |

Shut off the power to the unit, close the valves at the hot water supply port ③ and water inlet ④, and then connect the cleaning water circuit to the unit.

Cleaning water circuit is connected to the unit at the hot water supply port on the back of Heat pump unit ① and at the gas cooler inlet in the front of the Heat pump unit ② as shown in Figure 2.

Cleaning solution flows through the pipe indicated as ②, gas cooler, and then the pipe indicated as ① in Figure 2.

Set up the cleaning water circuit by removing built-in components from the unit as shown on the next page.



(1) Remove the cover from the water pipe box ①.

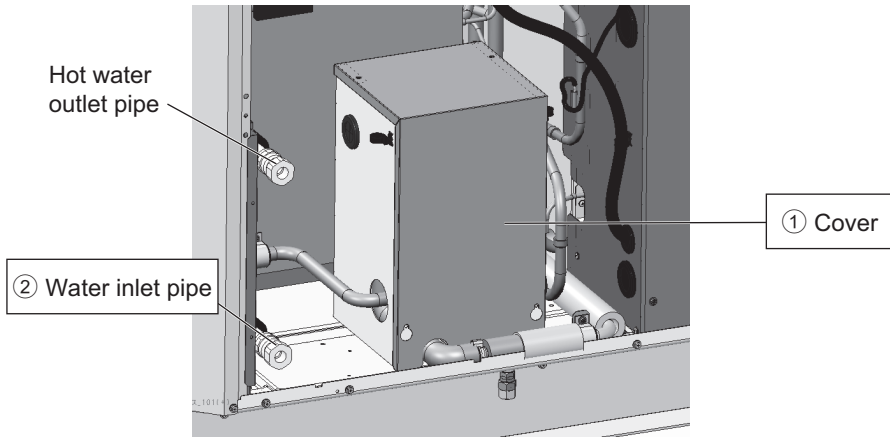

(2) Remove the water inlet pipe ② by removing the saddle ③ and quick fastener (for straight pipe) ④.

(3) Remove the gas cooler inlet pipe ⑥ by removing the quick fastener ⑤ (for reduced pipe).

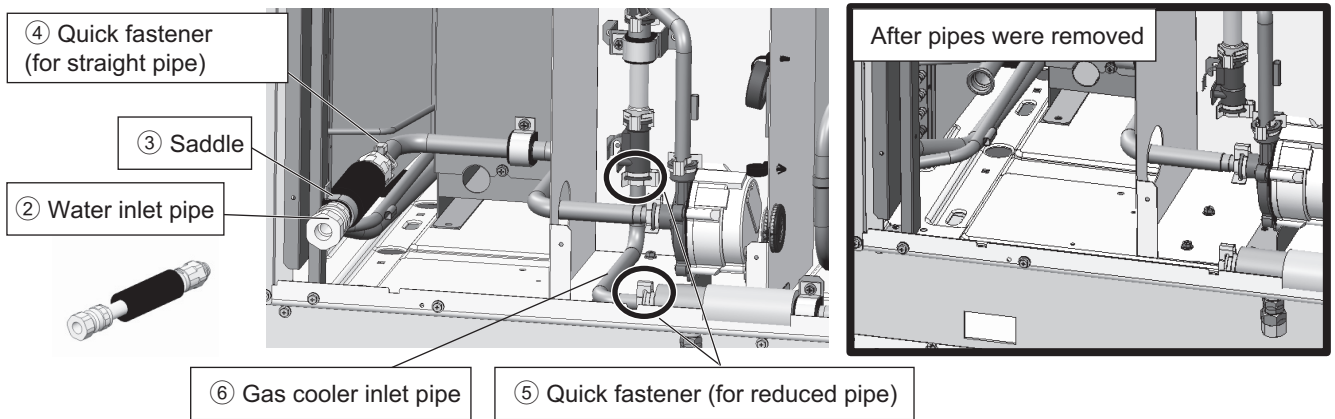

(4) Install the pipe as shown below, using a quick fastener ⑤ (for reduced pipe).

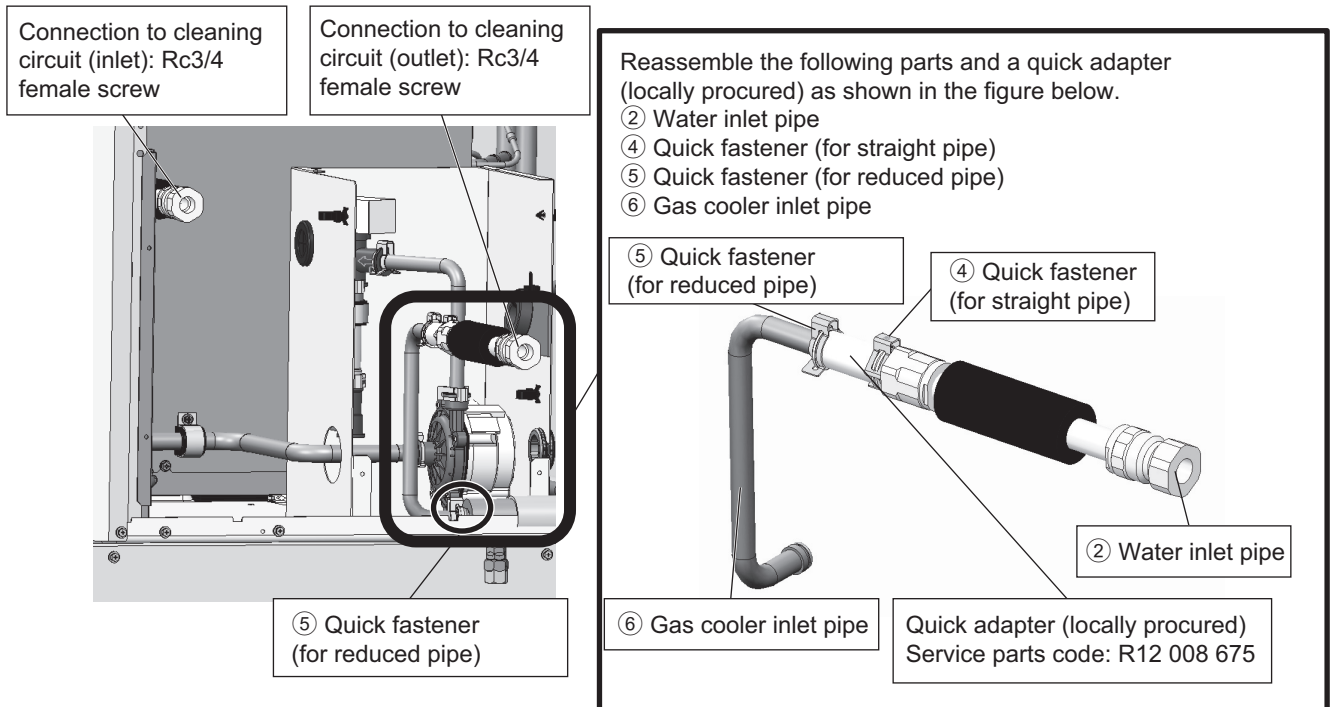

Set up the cleaning water circuit as shown in Figure 3. Numbers ① through ④ in the figure indicate the following items.

- ① Container (for cleaning)
- ② Pump
- ③ Submersible pump (placed in the container ① for exhaust water)
- ④ Container for exhaust water (also used to temporarily drain out cleaning solution when it starts foaming.)

After setting up the cleaning water circuit, place water in item ①, circulate the water, and check for leaks. After checking for leaks, replace the circulation water if it has become dirty. If not, the water can be reused for cleaning. Use as much of it as necessary for cleaning.

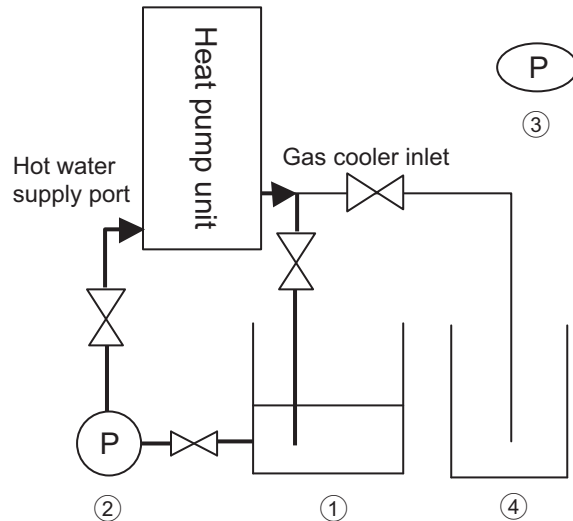
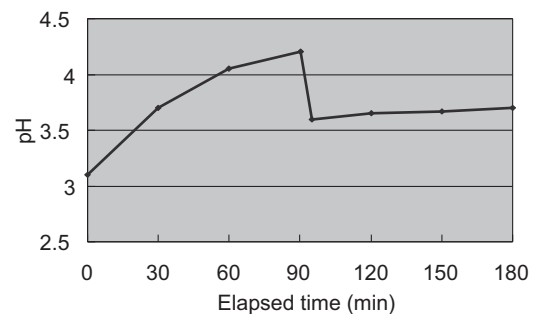

Figure 3 Cleaning water circuit

- 1) Make sure that the water inlet pipe has a port for connecting a pipe for chemical cleaning. Formic acid, citrate, oxalic acid, acetic acid, or phosphate acid diluted to 5% can be used as a cleaning solution to remove scale. Do not use hydrochloric acid, sulfuric acid, or nitric acid for cleaning because they are highly corrosive.
- 2) Make sure that valves are located before the inlet and after the outlet.
- 3) Connect the pipe for passing the cleaning solution to the inlet/outlet pipe on the gas cooler, fill the plate heat exchanger with cleaning agent heated to 50-60°C, and then let the solution circulate for two to five hours using a pump. The time needed to clean depends on the temperature of the cleaning solution or the degree of scaling. Observe the changes in the color of cleaning solution to determine how long the cleaning solution needs to be circulated.
- 4) When done cleaning, drain the cleaning solution from the gas cooler, fill the gas cooler with 1-2% sodium hydrate (NaOH) solution or with bicarbonic acid (NaHCO<sub>3</sub>) solution, and let the solution circulate for 15 to 20 minutes to neutralize the cleaning solution.
- 5) When done, thoroughly rinse inside the gas cooler with clean water.
- 6) When using a commercially available cleaning solution, make sure that it is not corrosive to stainless steel or copper beforehand.
- 7) For details of cleaning, consult the cleaning solution manufacturer.

**1) pH (to be measured with a pH tester)**

The graph at right shows the relationship between the elapsed time from the beginning of cleaning and the changes in pH. Cleaning solution will dissolve scale into the cleaning solution, which will gradually raise the pH of the cleaning solution. When the rise in pH begins to slow down (at 90 minutes in the graph at right), add the cleaning solution so the pH will drop to 0.5. If the pH rises after the solution is added, keep cleaning to remove the remaining scale. If there is no obvious rise in the pH, stop cleaning. Not much more of scale can be removed.



**2) Appearance of the cleaning solution**

The cleaning solution is pale yellow at the beginning. When scale is dissolved into the solution, the color may turn to brown or dark brown. This is normal.

**3) Flow rate (to be measured with a water-pressure gauge)**

Flow rate will increase as the scale is removed. (A rise in flow rate indicates scale is being removed.)

Connect the container to collect used cleaning water as shown in Figure 4.

Exhaust water drainage route (See Figure 4.): (①→②→Heat pump unit→④)

Using a submersible pump, drain the cleaning water in the cleaning water tank to the exhaust water tank.

Order in which submersible pump is to be used (See Figure 4.): (③→④)

Use this circuit for rinsing out the system with water after cleaning.

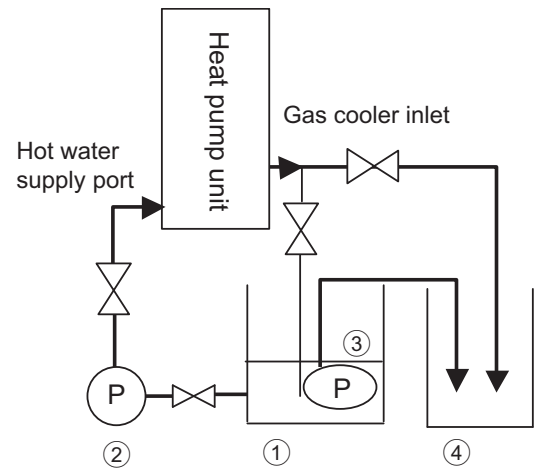

Figure 4 Exhaust water circuit

**(5) Restoring the water circuit**

After rinsing out after neutralizing the water circuit, restore the water circuit.

Then, open all valves at the hot water supply port ③, and water inlet ④.

**(6) Air-vent operation**

Perform an air-vent operation.

Operating the system with the air trapped in the pipe will leave the built-in pump idling for a long time and will result in malfunction.

**① Disposal of exhaust water**

Do not drain the exhaust water into a drain ditch. Collect the exhaust water, have it properly disposed of by an authorized industrial waste disposal agency.

---

## X Attachments

[1] R744 refrigerant saturation temperature table .....	167
---	-----



**[1] R744 refrigerant saturation temperature table**

Pressure MPag	Temp. °C	Pressure MPag	Temp. °C	Pressure MPag	Temp. °C	Pressure MPag	Temp. °C	Pressure MPag	Temp. °C	Pressure MPag	Temp. °C
0.50	-53.12	1.82	-20.83	3.14	-2.73	4.46	10.52	5.78	21.11	7.10	29.92
0.52	-52.33	1.84	-20.49	3.16	-2.50	4.48	10.69	5.80	21.26	7.12	30.04
0.54	-51.56	1.86	-20.16	3.18	-2.27	4.50	10.87	5.82	21.40	7.14	30.16
0.56	-50.82	1.88	-19.83	3.20	-2.05	4.52	11.05	5.84	21.55	7.16	30.28
0.58	-50.09	1.90	-19.50	3.22	-1.82	4.54	11.22	5.86	21.69	7.18	30.40
0.60	-49.37	1.92	-19.18	3.24	-1.60	4.56	11.40	5.88	21.83	7.20	30.52
0.62	-48.67	1.94	-18.86	3.26	-1.37	4.58	11.57	5.90	21.98	7.22	30.64
0.64	-47.98	1.96	-18.54	3.28	-1.15	4.60	11.74	5.92	22.12	7.24	30.76
0.66	-47.31	1.98	-18.22	3.30	-0.93	4.62	11.92	5.94	22.26	7.26	30.88
0.68	-46.65	2.00	-17.90	3.32	-0.71	4.64	12.09	5.96	22.41		
0.70	-46.01	2.02	-17.59	3.34	-0.49	4.66	12.26	5.98	22.55		
0.72	-45.37	2.04	-17.28	3.36	-0.27	4.68	12.43	6.00	22.69		
0.74	-44.75	2.06	-16.97	3.38	-0.06	4.70	12.60	6.02	22.83		
0.76	-44.14	2.08	-16.66	3.40	0.16	4.72	12.77	6.04	22.97		
0.78	-43.53	2.10	-16.36	3.42	0.38	4.74	12.94	6.06	23.11		
0.80	-42.94	2.12	-16.06	3.44	0.59	4.76	13.11	6.08	23.25		
0.82	-42.36	2.14	-15.76	3.46	0.81	4.78	13.28	6.10	23.39		
0.84	-41.79	2.16	-15.46	3.48	1.02	4.80	13.45	6.12	23.53		
0.86	-41.22	2.18	-15.16	3.50	1.23	4.82	13.62	6.14	23.67		
0.88	-40.67	2.20	-14.86	3.52	1.44	4.84	13.79	6.16	23.81		
0.90	-40.12	2.22	-14.57	3.54	1.65	4.86	13.95	6.18	23.95		
0.92	-39.58	2.24	-14.28	3.56	1.86	4.88	14.12	6.20	24.08		
0.94	-39.05	2.26	-13.99	3.58	2.07	4.90	14.28	6.22	24.22		
0.96	-38.53	2.28	-13.70	3.60	2.28	4.92	14.45	6.24	24.36		
0.98	-38.01	2.30	-13.42	3.62	2.48	4.94	14.61	6.26	24.50		
1.00	-37.50	2.32	-13.13	3.64	2.69	4.96	14.78	6.28	24.63		
1.02	-37.00	2.34	-12.85	3.66	2.90	4.98	14.94	6.30	24.77		
1.04	-36.51	2.36	-12.57	3.68	3.10	5.00	15.11	6.32	24.90		
1.06	-36.02	2.38	-12.29	3.70	3.30	5.02	15.27	6.34	25.04		
1.08	-35.53	2.40	-12.01	3.72	3.51	5.04	15.43	6.36	25.17		
1.10	-35.06	2.42	-11.74	3.74	3.71	5.06	15.59	6.38	25.31		
1.12	-34.59	2.44	-11.46	3.76	3.91	5.08	15.75	6.40	25.44		
1.14	-34.12	2.46	-11.19	3.78	4.11	5.10	15.91	6.42	25.58		
1.16	-33.66	2.48	-10.92	3.80	4.31	5.12	16.07	6.44	25.71		
1.18	-33.21	2.50	-10.65	3.82	4.51	5.14	16.23	6.46	25.84		
1.20	-32.76	2.52	-10.38	3.84	4.71	5.16	16.39	6.48	25.98		
1.22	-32.31	2.54	-10.12	3.86	4.91	5.18	16.55	6.50	26.11		
1.24	-31.87	2.56	-9.85	3.88	5.10	5.20	16.71	6.52	26.24		
1.26	-31.44	2.58	-9.59	3.90	5.30	5.22	16.87	6.54	26.37		
1.28	-31.01	2.60	-9.32	3.92	5.50	5.24	17.03	6.56	26.50		
1.30	-30.58	2.62	-9.06	3.94	5.69	5.26	17.18	6.58	26.63		
1.32	-30.16	2.64	-8.80	3.96	5.88	5.28	17.34	6.60	26.77		
1.34	-29.75	2.66	-8.55	3.98	6.08	5.30	17.50	6.62	26.90		
1.36	-29.33	2.68	-8.29	4.00	6.27	5.32	17.65	6.64	27.03		
1.38	-28.93	2.70	-8.03	4.02	6.46	5.34	17.81	6.66	27.16		
1.40	-28.52	2.72	-7.78	4.04	6.65	5.36	17.96	6.68	27.28		
1.42	-28.12	2.74	-7.53	4.06	6.84	5.38	18.12	6.70	27.41		
1.44	-27.72	2.76	-7.28	4.08	7.03	5.40	18.27	6.72	27.54		
1.46	-27.33	2.78	-7.03	4.10	7.22	5.42	18.42	6.74	27.67		
1.48	-26.94	2.80	-6.78	4.12	7.41	5.44	18.58	6.76	27.80		
1.50	-26.56	2.82	-6.53	4.14	7.60	5.46	18.73	6.78	27.93		
1.52	-26.18	2.84	-6.28	4.16	7.79	5.48	18.88	6.80	28.05		
1.54	-25.80	2.86	-6.04	4.18	7.97	5.50	19.03	6.82	28.18		
1.56	-25.42	2.88	-5.79	4.20	8.16	5.52	19.18	6.84	28.31		
1.58	-25.05	2.90	-5.55	4.22	8.34	5.54	19.33	6.86	28.43		
1.60	-24.68	2.92	-5.31	4.24	8.53	5.56	19.48	6.88	28.56		
1.62	-24.32	2.94	-5.07	4.26	8.71	5.58	19.63	6.90	28.68		
1.64	-23.96	2.96	-4.83	4.28	8.89	5.60	19.78	6.92	28.81		
1.66	-23.60	2.98	-4.59	4.30	9.08	5.62	19.93	6.94	28.93		
1.68	-23.24	3.00	-4.36	4.32	9.26	5.64	20.08	6.96	29.06		
1.70	-22.89	3.02	-4.12	4.34	9.44	5.66	20.23	6.98	29.18		
1.72	-22.54	3.04	-3.89	4.36	9.62	5.68	20.38	7.00	29.30		
1.74	-22.19	3.06	-3.65	4.38	9.80	5.70	20.53	7.02	29.43		
1.76	-21.84	3.08	-3.42	4.40	9.98	5.72	20.67	7.04	29.55		
1.78	-21.50	3.10	-3.19	4.42	10.16	5.74	20.82	7.06	29.67		
1.80	-21.16	3.12	-2.96	4.44	10.34	5.76	20.97	7.08	29.80		

[ X Attachments ]

---



# Service Handbook

Model  
QAHV-N560YA-HPB

**mitsubishi** **ELECTRIC CORPORATION**

[www.MitsubishiElectric.com](http://www.MitsubishiElectric.com)