

ecodan[®]

Renewable Heating Technology

MITSUBISHI ELECTRIC PRE-PLUMBED UNVENTED MAINS PRESSURE WATER HEATER
WITH FTC6 CONTROL SYSTEM FOR USE WITH THE ECODAN
AIR SOURCE HEAT PUMP RANGE

150, 170, 210, 250 and 300 LITRE CAPACITY STANDARD MODELS

210, 250 and 300 LITRE CAPACITY SOLAR MODELS

150 and 170 LITRE CAPACITY SLIMLINE MODELS

INSTALLATION AND SERVICING INSTRUCTIONS

IMPORTANT: PLEASE READ AND UNDERSTAND THESE INSTRUCTIONS
BEFORE COMMENCING INSTALLATION. PLEASE LEAVE THIS MANUAL
WITH THE CUSTOMER FOR FUTURE REFERENCE.

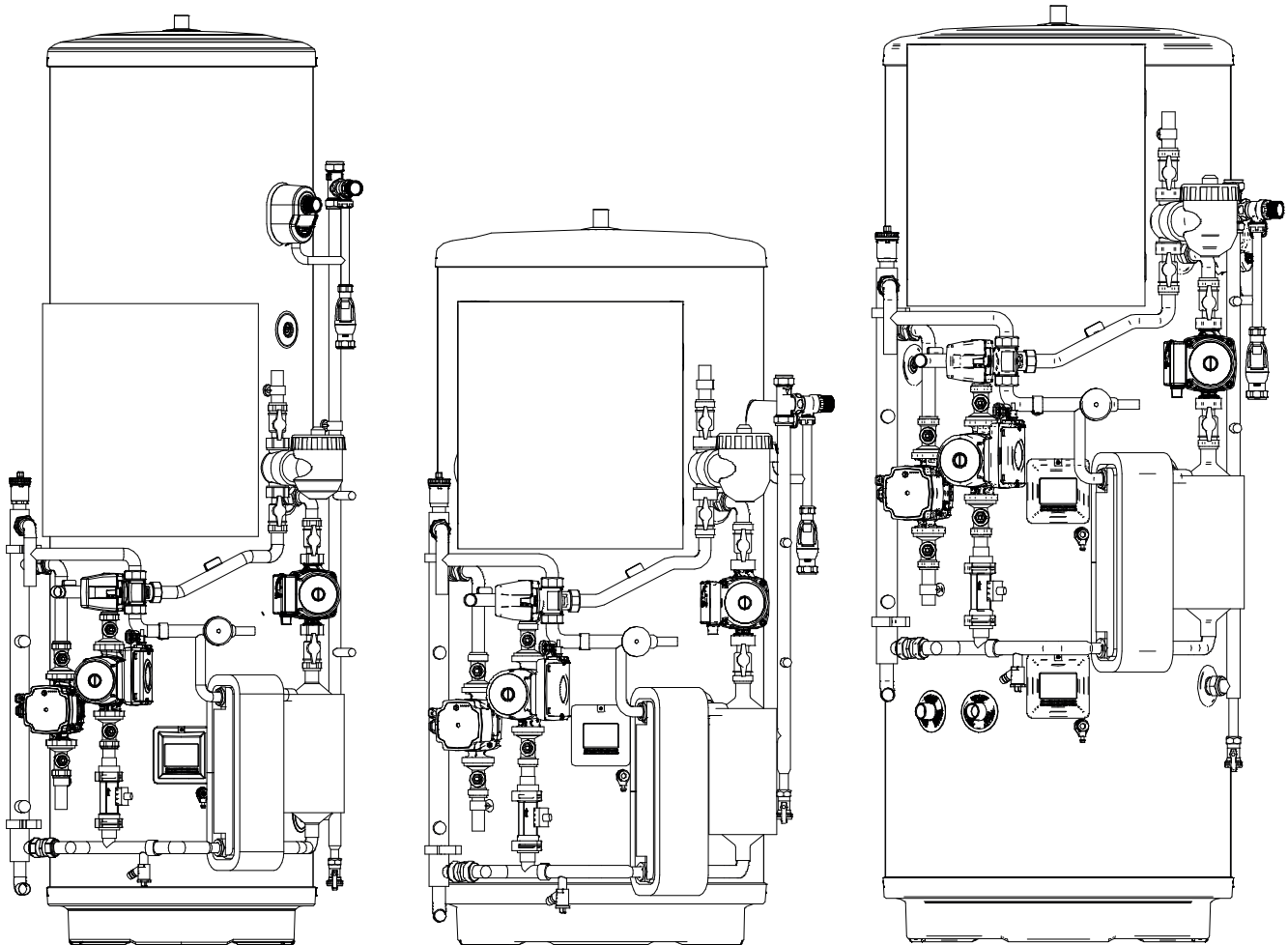

CONTENTS

SAFETY NOTICES	2
INTRODUCTION.....	4
GENERAL REQUIREMENTS	6
INSTALLATION – GENERAL.....	18
INSTALLATION - DISCHARGE	21
INSTALLATION - HEAT PUMP PRIMARY CIRCUIT.....	24
INSTALLATION - SOLAR PRIMARY.....	33
INSTALLATION - IMMERSION HEATER ELECTRICAL SUPPLY.....	34
INSTALLATION - WI-FI ADAPTER.....	34
COMMISSIONING	35
MAINTENANCE	36
FAULT FINDING & SERVICING	38
SPARE PARTS.....	38
USER INSTRUCTIONS.....	41
ENVIRONMENTAL INFORMATION.....	44
TECHNICAL SUPPORT	44

SAFETY NOTICES

Please read the following safety precautions carefully.





⚠ WARNING:
Precautions that must be observed to prevent injuries or death.

⚠ CAUTION:
Precautions that must be observed to prevent damage to unit.

This installation manual along with the user manual should be left with the product after installation for future reference.
Mitsubishi Electric is not responsible for the failure of locally-supplied parts.

- Be sure to perform periodical maintenance.
- Be sure to follow your local regulations.
- Be sure to follow the instructions provided in this manual.

MEANINGS OF SYMBOLS DISPLAYED ON THE UNIT

	WARNING (Risk of fire)	This mark is for R32 refrigerant only. Refrigerant type is written on nameplate of outdoor unit. In case that refrigerant type is R32, this unit uses a flammable refrigerant. If refrigerant leaks and comes in contact with fire or heating part, it will create harmful gas and there is risk of fire.
	Read the OPERATION MANUAL carefully before operation.	
	Service personnel are required to carefully read the OPERATION MANUAL and INSTALLATION MANUAL before operation.	
	Further information is available in the OPERATION MANUAL, INSTALLATION MANUAL, and the likes.	

SAFETY NOTICES

WARNING

Mechanical

- The cylinder unit and outdoor unit must not be installed, disassembled, relocated, altered or repaired by the user. Ask an authorised installer or technician. If the unit is installed improperly or modified after installation, water leakage, electric shock or fire may result.
- The outdoor unit should be securely fixed to a hard level surface capable of bearing its weight.
- The cylinder unit should be positioned on a hard level surface capable of supporting its filled weight to prevent excessive sound or vibration.
- Do not position furniture or electrical appliances below the outdoor unit or cylinder unit.
- The discharge pipework from the emergency devices of the cylinder unit should be installed according to local law.
- Only use accessories and replacement parts authorised by Mitsubishi Electric ask a qualified technician to fit the parts.

Electrical

- All electrical work should be performed by a qualified technician according to local regulations and the instructions given in this manual.
- The units must be powered by a dedicated power supply and the correct voltage and circuit breakers must be used.
- Wiring should be in accordance with national wiring regulations. Connections must be made securely and without tension on the terminals.
- Earth unit correctly.

General

- Keep children and pets away from both the cylinder unit and outdoor unit.
- Do not use the hot water produced by the heat pump directly for drinking or cooking. This could cause illness to the user.
- Do not stand on the units.
- Do not touch switches with wet hands.
- Annual maintenance checks on both the cylinder unit and the outdoor unit should be conducted by a qualified person.
- Do not place containers with liquids on top of the cylinder unit. If they leak or spill onto the cylinder unit damage to the unit and/or fire could occur.
- Do not place any heavy items on top of the cylinder unit.
- When installing, relocating, or servicing the cylinder unit, use only the heat pump's specified refrigerant to charge the refrigerant lines. Do not mix it with any other refrigerant and do not allow air to remain in the lines. If air is mixed with the refrigerant, then it can be the cause of abnormal high pressure in the refrigerant line, and may result in an explosion and other hazards.
- The use of any refrigerant other than that specified for the system will cause mechanical failure or system malfunction or unit breakdown. In the worst case, this could lead to a serious impediment to securing product safety.
- In heating mode, to avoid the heat emitters being damaged by excessively hot water, set the target flow temperature to a minimum of 2°C below the maximum allowable temperature of all the heat emitters. For Zone2, set the target flow temperature to a minimum of 5°C below the maximum allowable flow temperature of all the heat emitters in Zone2 circuit.
- Do not install the unit where combustible gases may leak, be produced, flow, or accumulate. If combustible gas accumulates around the unit, fire or explosion may result.
- Do not use means to accelerate the defrosting process or to clean, other than those recommended by the manufacturer.
- The appliance shall be stored in a room without continuously operating ignition sources (for example: open flames, an operating gas appliance or an operating electric heater).
- Do not pierce or burn.
- Be aware that refrigerants may not contain an odour.
- Pipe-work shall be protected from physical damage.
- The installation of pipe-work shall be kept to a minimum.
- Compliance with national gas regulations shall be observed.
- Keep any required ventilation openings clear of obstruction.
- Do not use low temperature solder alloy in case of brazing the refrigerant pipes.
- If the refrigeration gas leaks, stop the operation of the system, thoroughly ventilate the room and contact your dealer.

CAUTION

- Use clean water that meets local quality standards on the primary circuit.
- The outdoor unit should be installed in an area with sufficient airflow according to the diagrams in the outdoor unit installation manual.
- The cylinder unit should be located inside to minimise heat loss.
- Water pipe-runs on the primary circuit between outdoor and indoor unit should be kept to a minimum to reduce heat loss.
- Ensure condensate from outdoor unit is piped away from the base to avoid puddles of water.
- Remove as much air as possible from the primary and DHW circuits.
- Refrigerant leakage may cause suffocation. Provide ventilation in accordance with EN378-1.
- Be sure to wrap insulation around the piping. Direct contact with the bare piping may result in burns or frostbite.
- Never put batteries in your mouth for any reason to avoid accidental ingestion.
- Install the unit on a rigid structure to prevent excessive sound or vibration during operation.
- Battery ingestion may cause choking and/or poisoning.
- Do not transport the cylinder unit with water inside the DHW tank. This could cause damage to the unit.
- If power to the cylinder unit is to be turned off (or system switched off) for a long time, the water should be drained.
- If unused for a long period, before operation is resumed, DHW tank should be flushed through with potable water.
- Preventative measures should be taken against water hammer, such as installing a Water Hammer Arrestor on the primary water circuit, as directed by the manufacturer.

As for the handling of refrigerant, refer to the outdoor unit installation manual.

INTRODUCTION

This range of factory pre-plumbed and wired unvented water heaters are specifically designed for use with the Mitsubishi Ecodan Air Source Heat Pump range. The cylinder is manufactured in the UK from top quality materials and meets all the latest relevant safety and constructional standards. The high grade Duplex stainless steel cylinder offers exceptional strength and corrosion resistance. Its performance, control system and insulation levels exceed the latest requirements of Building Regulation Part L.

The unvented water heater can be fed directly from the cold water mains supply to the property without the need for separate feed cisterns or vent pipes. It is supplied fitted with all its necessary inlet and safety controls for compliance with Building Regulations. Also fitted are primary circulating pump, heating circulating pump, DHW circulating pump, primary to DHW plate to plate heat exchanger, 3 way diverter valve, magnetic and cyclonic filter, scale trap, low loss header, flow sensor, automatic air vent, primary filling loop and pressure gauge, a cylinder thermal cut-out, WI-Fi adaptor and Mitsubishi Electric FTC6 controller. The pumps, motorised valve and thermal controls are supplied pre-wired. The DHW expansion vessel is supplied loose for installation at a convenient position within the property. An electric immersion heater is also fitted to enable the unit to be heated should the heat pump require supplementary heating or be turned off.

NOTE: If using a sealed heating system, adequate provision for expansion within the primary circuit MUST be provided by fitting a primary circuit expansion vessel. Primary circuit expansion cannot be accommodated within the Air Source Heat Pump cylinder. A primary circuit pressure relief valve is fitted within the Mitsubishi Ecodan air source heat pump outdoor unit.

The safety valves fitted to the Air Source Heat Pump cylinder protect the water heater only. Failure to provide adequate primary system pressure relief when using a sealed heating system will invalidate the Heat Pump warranty. Consult the Heat Pump installation instructions for further advice.

IMPORTANT NOTE TO THE INSTALLER

The pre-plumbed cylinder is specifically designed to be installed in conjunction with an air source heat pump. The pre-plumbed cylinder is available in either STANDARD, SOLAR or SLIMLINE models.

Please read these instructions before commencing installation. Unvented cylinders are a controlled service as defined in the latest edition of the building regulations and should only be carried out by a competent, qualified installer. The relevant regulations are:

England and Wales - Building Regulation Part G Section G3

Scotland - Technical Standard Section 4

Northern Ireland - Building Regulation Part F

After installation the Benchmark log book and included commissioning sheets must be completed and left along with these instructions with the householder for future reference.

Any water distribution and central heating installation must comply with the relevant recommendations of the current version of the Regulations and British Standards listed below:

Building Regulations

IEE Requirements for Electrical Installations (BS 7671)

Water Regulations

Manual Handling Operations Regulations

British Standards BS6798, BS5449, BS5540:1, BS5540:2, CP331:3, BS8558, BS7593 and BS7671

Health and Safety Document No. 635

Only qualified and/or competent individuals should install the Ecodan system. Mitsubishi Electric's notes must not be taken as overriding statutory obligations.

An annual inspection of the system will be required to ensure safe, long term operation.

The information in this manual is provided to assist generally in the selection of equipment. The responsibility for the selection and specification of the equipment must however, remain with the installer and any designers or consultants concerned with the design, specification and installation of the system. Please note: Mitsubishi Electric does not therefore accept any responsibility for matters of design, selection or specification or for the effectiveness of an installation containing one of its products unless specifically requested to do so and expressly agreed in writing by Mitsubishi Electric at production stage.

All goods are sold subject to Mitsubishi Electric's Terms and Conditions of Sale.

Important Note:

Included with the Ecodan product is information about how to register the Mitsubishi Electric user guarantee. Please direct the end user to register within 3 months of commissioning and ensure they benefit from the applicable standard guarantee for their Ecodan heat pump and any cylinder or interfacing equipment purchased from Mitsubishi Electric by you as installer. The guarantee applies where the installation address is in England, Scotland or Wales only and for domestic use.

This registration should be completed only by the end user/system owner so please ensure that the information about how to register the Mitsubishi Electric user guarantee reaches them. There are various options to register the guarantee and details can be found online at <https://les.mitsubishielectric.co.uk/homeowners/register-ecodan-guarantee>. The registration is logged by our warranty department. In the unlikely event of failure of the Ecodan heat pump or any such cylinder or interfacing equipment purchased from Mitsubishi Electric, registration of the guarantee ensures that warranty claims are processed efficiently. For further information on the Mitsubishi Electric user guarantee please contact us by email: ecodan.service@meuk.mee.com or telephone 0161 866 6064.

Please Note:

If you do not register the Mitsubishi Electric user guarantee then the product will only be guaranteed to the user by Mitsubishi Electric for 12 months from the date of commissioning.

Our commercial guarantee to your user does not affect your user's statutory rights or any consumer rights under applicable national legislation.

NOTE: This manual is for revision A products only, manufactured on or after week 18 2020 see DATA label and drawing below for details

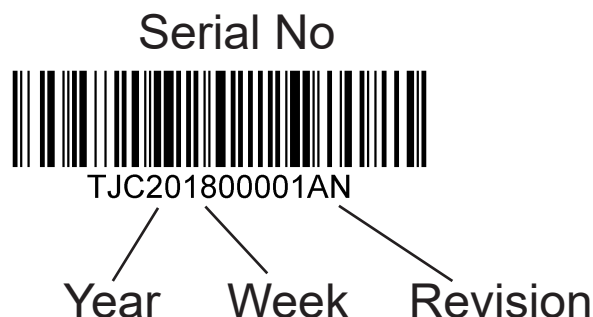

GENERAL REQUIREMENTS

IMPORTANT: THIS APPLIANCE CAN BE USED BY CHILDREN AGED FROM 8 YEARS AND ABOVE AND PERSONS WITH REDUCED PHYSICAL SENSORY OR MENTAL CAPABILITIES OR LACK OF EXPERIENCE AND KNOWLEDGE IF THEY HAVE BEEN GIVEN SUPERVISORY OR INSTRUCTION CONCERNING USE OF THE APPLIANCE IN A SAFE WAY AND UNDERSTAND THE HAZARDS INVOLVED. CHILDREN SHALL NOT PLAY WITH THE APPLIANCE. CLEANING AND USER MAINTENANCE SHALL NOT BE MADE BY CHILDREN WITHOUT SUPERVISION.

WARNING: Do not switch on if there is a possibility that the water in the heater is frozen.

COMPONENT CHECK LIST

Before commencing installation check that all the components for your Air Source Heat Pump cylinder are contained in the package. The following components are supplied with your unit :

- Factory fitted
 - Temperature and Pressure Relief Valve (set at 90°C/10bar)
 - Immersion heater and over-temperature cut-out
 - Expansion relief valve (comprises of expansion valve and check valve)
 - Tundish
 - Primary circulating pump - Grundfos UPM GEO 25-85 (150/170/210 litre models), Grundfos UPMXL GEO 25-125 (250/300 litre models)
 - Heating circulating pump - Grundfos UPM3 25-70 (all models)
 - DHW circulating pump -Grundfos UPSO 15-60 CIL 2
 - 3 Way motorised diverter valve
 - Primary to DHW plate to plate heat exchanger
 - Fernox TF1 Compact Magnetic filter
 - Primary circuit filling loop
 - Primary circuit pressure gauge
 - Scale trap
 - Low loss header
 - Flow sensor
 - Automatic air vent
 - WI-Fi adaptor
 - FTC6 Controller
 - Solar over-temperature thermal cutout (Solar models only)
- Supplied loose
 - Mitsubishi Electric CH/DHW Main Controller
 - Potable water expansion vessel + bracket
 - Cold water combination valve (comprises pressure reducing valve, strainer, check valve)

STORAGE AND HANDLING

Prior to installation the Pre-plumbed cylinder unit must be stored vertically upright on a secure, level surface in a dry, frost free environment. Take note of the weight of the product and follow safe working practices when lifting, moving or manipulating into position. DO NOT lift by the pre-plumbed pipework manifold.

SITING THE UNIT

The Pre-plumbed cylinder unit must be vertically floor mounted. It can be placed anywhere convenient provided the discharge pipe(s) from its safety valves can be correctly installed and all pre-fitted ancillary parts can be accessed for servicing and/or maintenance. Areas that are subject to freezing must be avoided. Ensure that the floor is of sufficient strength to support the "full" weight of the unit (Table 1, page 7). Pipe runs should be kept as short as possible for maximum economy.

Additional automatic air vents (AAV) (not supplied) may be required at high points in the primary system where pipework is located above the level of the cylinder. After filling the system (primary circuit), release all trapped air using air vents during and following heating period and top up with water as necessary. After removing the air, automatic air vent(s) MUST be closed.

WATER SUPPLY

Bear in mind that the water supply to the property will be supplying both the hot and cold water requirements simultaneously. It is recommended that the maximum water demand is assessed and the water supply checked to ensure this demand can be satisfactorily met.

NOTE: A high water pressure will not always guarantee high flow rates.

Wherever possible the cylinder supply pipe should be 22mm. We suggest the minimum supply requirements should be 1.5 bar pressure and 20 litres per minute flow rate. However, at these values outlet flow rates may be poor if several outlets are used simultaneously. The higher the available pressure and flow rate the better the system performance.

The cylinder has an operating pressure of 3.5 bar which is controlled by the cold water combination valve assembly. The cold water combination valve assembly can be connected to a maximum inlet pressure of 16 bar.

IMPORTANT INSTALLATION NOTE:

WHERE THE INLET SUPPLY TO THE PRESSURE REDUCING VALVE (PRV) IS ROUTED THROUGH A HEATED SPACE AND IS FITTED WITH A CHECK VALVE OR OTHER FITTING THAT WOULD PREVENT BACK FLOW, HIGH PRESSURES CAN BE EXPERIENCED IN THE INLET PIPE DUE TO WARMING THAT CAN CAUSE DAMAGE TO THE PRV OR OTHER FITTINGS ON THE INLET SUPPLY. IN THESE CIRCUMSTANCES, THE INSTALLATION OF A MEANS TO ACCOMMODATE EXPANSION AND THUS LIMIT THE PRESSURE RISE IN THE INLET PIPE IS RECOMMENDED. REFER TO THE INSTALLATION SECTION FOR FURTHER DETAILS.

OUTLET/TERMINAL FITTINGS (TAPS, ETC.)

The Pre-plumbed cylinder can be used in conjunction with most types of terminal fittings, plumbing fittings and pipework. However, the rated pressures of any fittings selected should be checked for compatibility before installation.

NOTE: Accessories, plumbing fittings and pipe work should have a rated operating pressure of at least 8 bar. Outlets situated higher than the cylinder will give outlet pressures lower than that at the unit, a 10m height difference will result in a 1 bar pressure reduction at the outlet fitting.

LIMITATIONS

The Pre-plumbed cylinder should not be used in association with any of the following:

- Solid fuel boilers or any other boiler in which the energy input is not under effective thermostatic control, unless additional and appropriate safety measures are installed.
- Ascending spray type bidets or any other class 1 back syphonage risk require that a type A air gap be employed.
- Steam heating plants unless additional and appropriate safety devices are installed.
- Situations where maintenance is likely to be neglected or safety devices tampered with.
- Water supplies that have either inadequate pressure or where the supply may be intermittent.
- Situations where it is not possible to safely pipe away any discharge from the safety valves.
- In areas where the water consistently contains a high proportion of solids, e.g. suspended matter that could block the strainer unless adequate filtration can be ensured.

OPERATIONAL SUMMARY

Maximum mains supply pressure	1.6 MPa (16 bar)
Operating pressure	0.35 MPa (3.5 bar)
Expansion vessel pressure	0.35 MPa (3.5 bar)
Maximum design (Rated) pressure	0.8 MPa (8 bar)
Expansion relief valve setting	0.8 MPa (8 bar)
T&P relief valve setting	90°C/1.0 MPa (10 bar)
T&P relief valve manufacturers ref	RWC PTEM 510003
Maximum primary circuit pressure	0.3 MPa (3 bar)
Maximum heating fluid temperature	85°C
Storage capacity	See Table 1 below
Weight when full	See Table 1 below

OUTLINE SPECIFICATIONS

The cylinders are designed, constructed and tested for compliance with BS EN 12897:2006

Outer casing: White pre-painted corrosion resistant steel

Water container: Duplex stainless steel. 100% pressure tested to 1.5 MPa (15 bar).

Thermal insulation: CFC/HCFC free fire retardant expanded polyurethane foam with zero ozone depletion potential. It has a Global Warming Potential (GWP) of 3.1. Nominal thickness Standard and Solar units 60mm, Slimline units 50mm.

Table 1 - Unit Weights & Standing Heat Loss

Model Type	Nominal Capacity (litres)	Weight of full unit (kg)	Weight of unit (kg)	Standing Heat Loss	
				per day (kWh/24h)	per year (kWh/365d)
Standard	150	205	55	1.15	419.7
Standard	170	228	58	1.23	448.9
Standard	210	274	64	1.53	558.5
Standard	250	320	70	1.80	657.0
Standard	300	378	78	2.09	762.9
Solar	210	278	68	1.57	573.1
Solar	250	325	75	1.79	653.4
Solar	300	383	83	1.88	686.2
Slimline	150	209	59	1.40	511.0
Slimline	170	233	63	1.59	580.4

Fig 1 - Parts identification

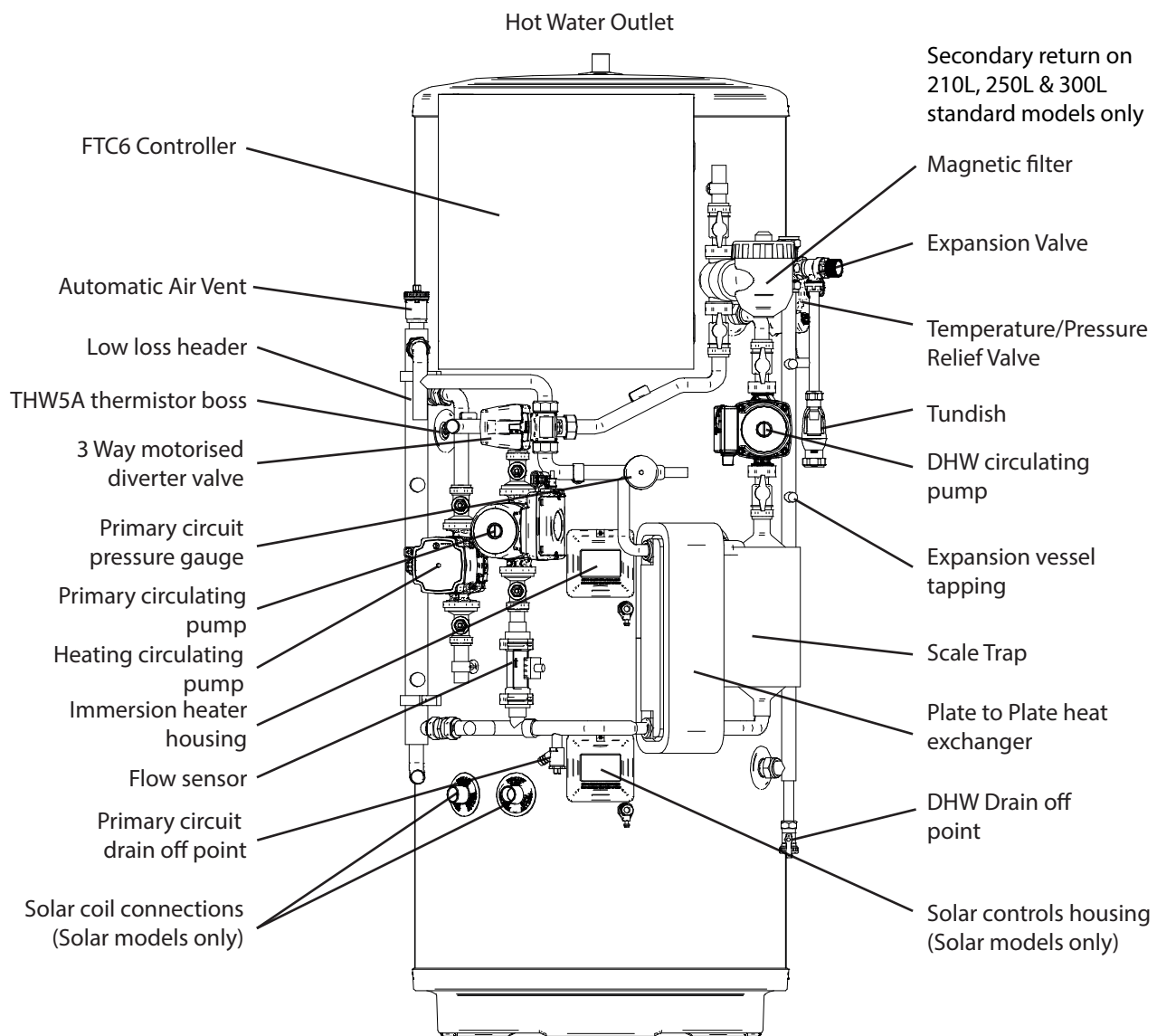

Indicative Performance

Nominal capacity (litres)	Type	Hot water capacity (litres)	Reheat time (minutes)	Nominal heat input (kW)
150	Slimline	144	92	4.83
170	Slimline	175	69	7.85
150	Standard	153	65	7.20
300	Standard	301	172	5.38
300	Solar	302	135	6.88
				Average 6.43

NOTE: Heating times achieved using an Air Source Heat Pump with variable output power and boost heating to 60°C using a 3kW immersion heater and a primary (heat pump) flow rate of 20 l/min. Test method in accordance with EN12897:2006

Fig 2a - Dimensions and EU Product Fiche- Standard models

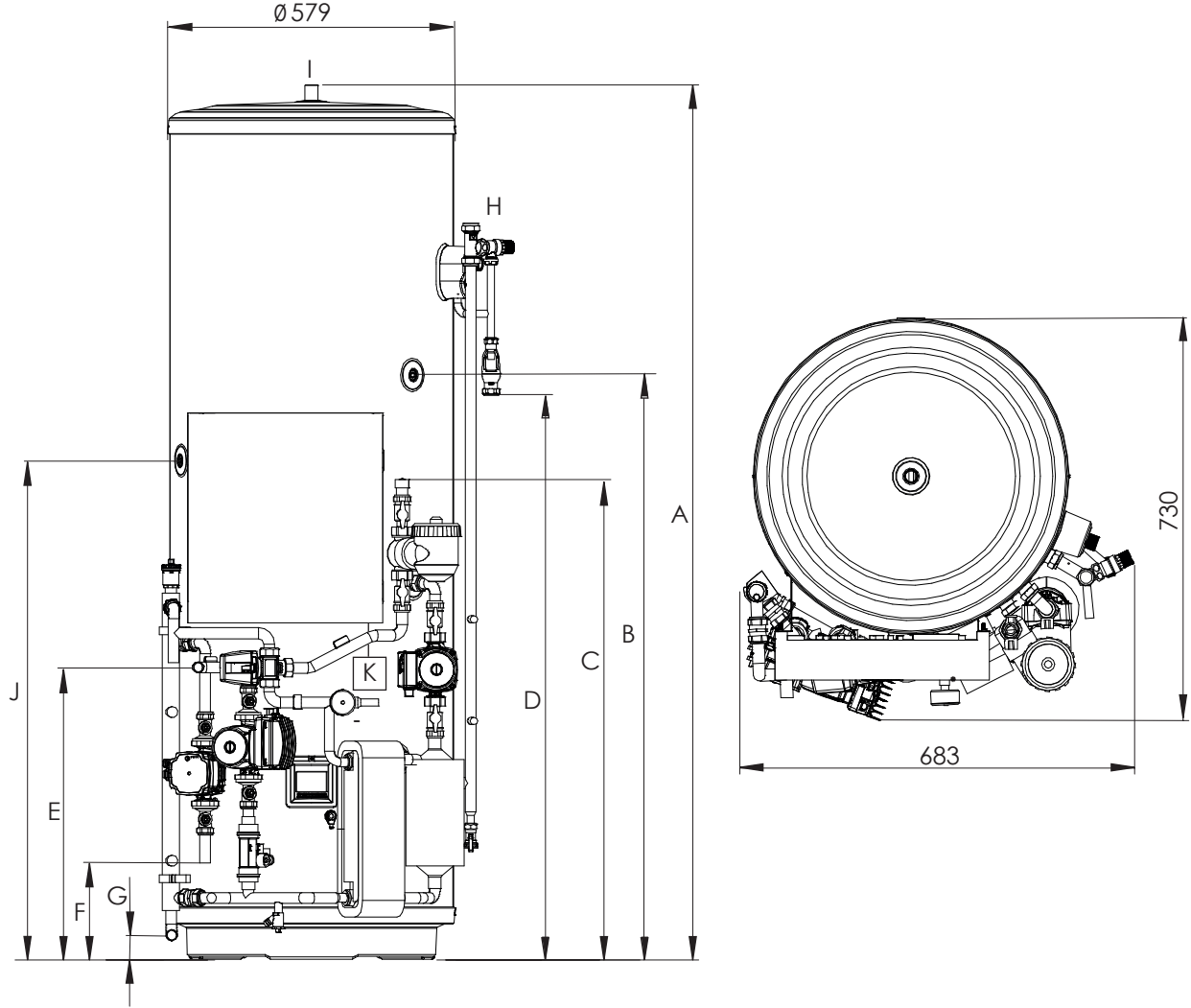

KEY

- A OVERALL HEIGHT
- B SECONDARY RETURN TAPPING
- C HEAT PUMP FLOW CONNECTION (22mm O/D COPPER)
- D TUNDISH OUTLET CONNECTION (22mm COMPRESSION)
- E HEAT PUMP RETURN CONNECTION (22mm O/D COPPER)
- F HEATING CIRCUIT FLOW CONNECTION (22mm O/D COPPER)
- G HEATING CIRCUIT RETURN CONNECTION (22mm O/D COPPER)
- H COLD WATER INLET CONNECTION (22mm COMPRESSION)
- I HOT WATER OUTLET CONNECTION (22mm COMPRESSION / 3/4" BSP M)
- J THW5A SENSOR POCKET
- K WI-FI ADAPTOR (INCLUDED, INSTALLER TO LOCATE AND MOUNT)

CAPACITY	150	170	210	250	300
A	1130	1256	1508	1760	2074
B	-	-	1050	1175	1385
C	990	990	990	990	990
D	505	630	880	1136	1450
E	585	585	585	585	585
F	195	195	195	195	195
G	50	50	50	50	50
J	675	815	925	1005	1193
K	Installer to locate and mount				

MODEL	150 Standard	170 Standard	210 Standard	250 Standard	300 Standard
Energy efficiency class	B	B	C	C	C
Standing loss in W	47.9	51.2	63.7	75.0	87.1
Storage volume V in Litres	150	170	210	250	300
Technical parameters in accordance with European Commission regulations 814/2013 and 812/2013					

Fig 2b - Dimensions and EU Product Fiche - Solar models

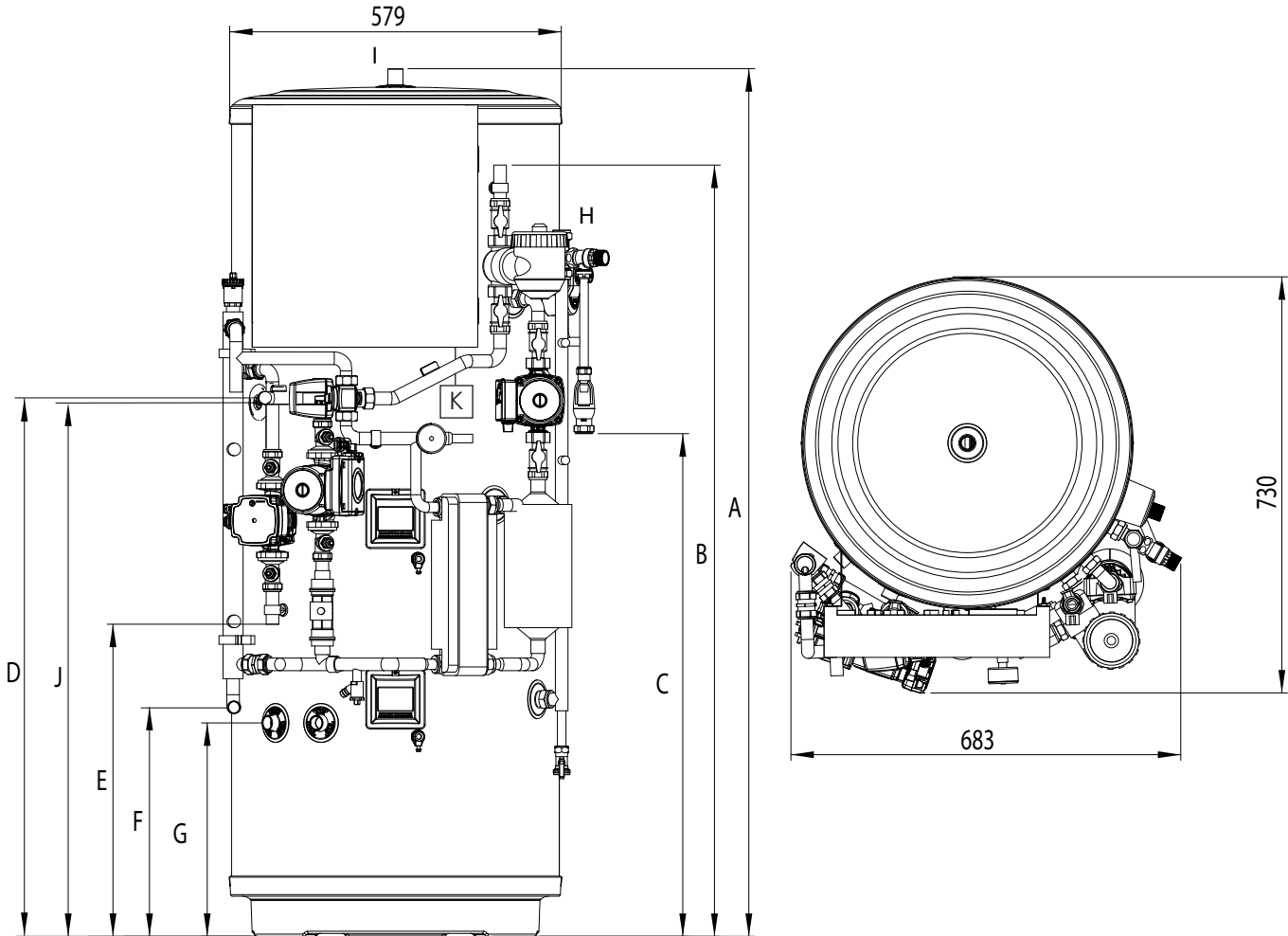

KEY

- A OVERALL HEIGHT
- B HEAT PUMP FLOW CONNECTION (22mm O/D COPPER)
- C TUNDISH OUTLET CONNECTION (22mm COMPRESSION)
- D HEAT PUMP RETURN CONNECTION (22mm O/D COPPER)
- E HEATING CIRCUIT FLOW CONNECTION (22mm O/D COPPER)
- F HEATING CIRCUIT RETURN CONNECTION (22mm O/D COPPER)
- G SOLAR COIL CONNECTIONS (22mm COMPRESSION / 3/4" BSP M)
- H COLD WATER INLET CONNECTION (22mm COMPRESSION)
- I HOT WATER OUTLET CONNECTION (22mm COMPRESSION / 3/4" BSP M)
- J THW5A SENSOR POCKET
- K WI-FI ADAPTOR (INCLUDED, INSTALLER TO LOCATE AND MOUNT)

CAPACITY	210	250	300
A	1513	1765	2081
B	1346	1346	1346
C	877	1129	1444
D	935	935	935
E	545	545	545
F	400	400	400
G	372	372	372
J	933	1008	1198
K	Installer to locate and mount		

Solar coil specification:

Surface Area: 1.1m²
 Coil volume: 5.8 litres
 Pressure drop: 3.6 kPa (0.036 bar)
 Output rating: 30kW at 80°C flow temperature, 15 litres/minute flow rate
 Connections: 22mm compression / 3/4" BSP male
 Dedicated solar volume: 75 litres

MODEL	210 Solar	250 Solar	300 Solar
Energy efficiency class	C	C	C
Standing loss in W	65.4	74.6	78.3
Storage volume V in Litres	210	250	300
Technical parameters in accordance with European Commission regulations 814/2013 and 812/2013			

Fig 2c - Dimensions and EU Product Fiche- Slimline models

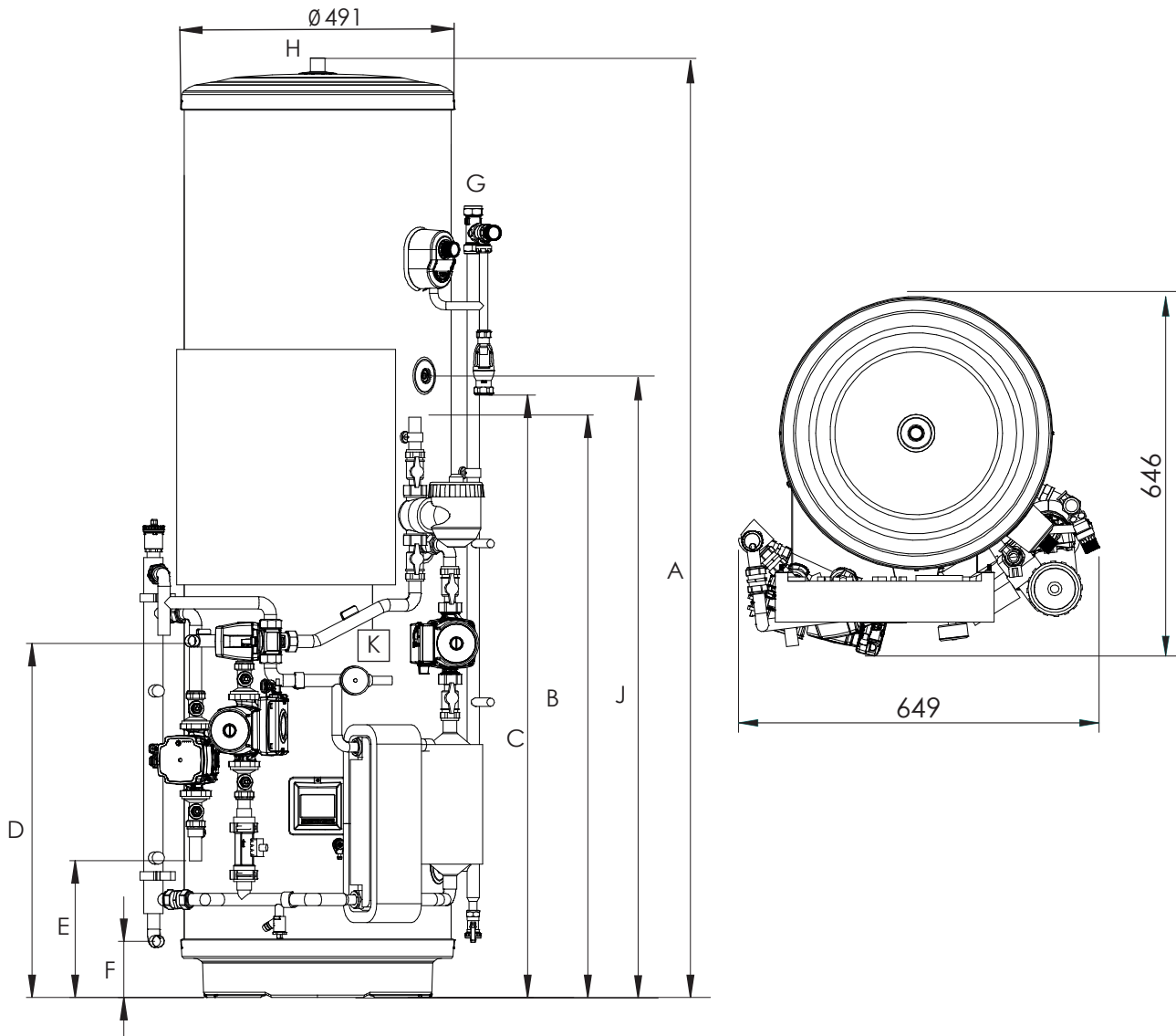

KEY

- A OVERALL HEIGHT
- B HEAT PUMP FLOW CONNECTION (22mm O/D COPPER)
- C TUNDISH OUTLET CONNECTION (22mm COMPRESSION)
- D HEAT PUMP RETURN CONNECTION (22mm O/D COPPER)
- E HEATING CIRCUIT FLOW CONNECTION (22mm O/D COPPER)
- F HEATING CIRCUIT RETURN CONNECTION (22mm O/D COPPER)
- G COLD WATER INLET CONNECTION (22mm COMPRESSION)
- H HOT WATER OUTLET CONNECTION (22mm COMPRESSION / 3/4" BSP M)
- J THW5A SENSOR POCKET
- K WI-FI ADAPTOR (INCLUDED, INSTALLER TO LOCATE AND MOUNT)

CAPACITY	150	170
A	1515	1689
B	1043	1043
C	909	1083
D	640	640
E	246	246
F	101	101
J	943	1117
K	Installer to locate and mount	

MODEL	150 Slimline	170 Slimline
Energy efficiency class	C	C
Standing loss in W	58.3	66.3
Storage volume V in Litres	150	170
Technical parameters in accordance with European Commission regulations 814/2013 and 812/2013		

Table 2 - STANDARD Cylinder Technical Data

UNIT		STANDARD				
		150	170	210	250	300
Nominal hot water capacity (litres)		14/17/24/32/40 l/min				
Water		Primary - Grundfos UMPGEO OR UPMXL GEO, Heating - Grundfos UPM3, DHW - Grundfos UPSO 15-60 CIL2				
Primary flow rate (H) WM 50/60/85/112/140		22				
Connection size Heating/DHW (mm)		12 18 18 24 24 24				
DHW Expansion vessel (litres)		0.35 (3.5)				
Charge pressure (MPa (bar))		80				
Control thermistor (°C)		0.3 (3.0) Contained within outdoor unit				
Pressue Relief Valve (MPa (bar))		75				
Control thermistor (°C)		80 +/- 5				
Over-temperature cut-out (°C)		90 / 1.0 (10.0)				
Temp/Pressure Relief Valve (°C/MPa (bar))		0.8 (8.0)				
Expansion valve (MPa (bar))		683 683 683 683 683				
Width		730 730 730 730 730				
Depth		1130 1256 1508 1760 2074				
Height		56 / 206 62 / 232 69 / 279 77 / 327 87 / 387				
Weight empty/full (kg)		Duplex stainless steel				
Materials		Expanded polyurethane (PU)				
Vessel		60				
Insulation		1.15 1.23 1.53 1.80 2.09				
Nominal thickness (mm)		zero				
Standing heat loss (kWh/24h)		3.1				
Ozone Depletion Potential		220 - 240 V ~, 50Hz				
Global Warming Potential		single				
Electrical supply		16				
Phase		220 - 240 V ~, 50Hz				
Fuse rating - MCB Size (A)		single				
Electrical supply		3				
Phase		13				
Rating (kW at 240V)		16				
Max current (A)		DHW and 1 heating zone *				
Fuse rating - MCB Size (A)		PAR-WT50-E controller & PAR-WR51-E receiver				
Mechanical zones		* Optional 2-zone accessory pack available				
Optional wireles room thermostat and wireless receiver						

Table 3 - SOLAR Cylinder Technical Data

UNIT		SOLAR	
Nominal hot water capacity (litres)		210	250
Water		14/17/24/32/40 l/min	
		Primary - Grundfos UMPGEO OR UPMXL GEO, Heating - Grundfos UPM3, DHW - Grundfos UPSO 15-60 CIL2	
		22	
		18	24
		0.35 (3.5)	
		1.1	
		80	
		0.3 (3.0) Contained within outdoor unit	
		75	
		80 +/- 5	
		90 / 1.0 (10.0)	
		0.8 (8.0)	
		683	683
		730	730
		1513	1765
		74 / 284	82 / 332
		Duplex stainless steel	
		316L stainless steel	
		Expanded polyurethane (PU)	
		60	
		1.57	1.79
		zero	
		3.1	
		220 - 240 V ~, 50Hz	
		single	
		16	
		220 - 240 V ~, 50Hz	
		single	
		3	
		13	
		16	
		DHW and 1 heating zone*	
		PAR-WT50-E controller & PAR-WR51-E receiver	

* Optional 2-zone accessory pack available.

Table 4 - SLIMLINE Cylinder Technical Data

UNIT		SLIMLINE	
Nominal hot water capacity (litres)		150	170
Water		14/17/24 l/min	
		Primary - Grundfos UMPGEO, Heating - Grundfos UPM3, DHW - Grundfos UPSO 15-60 CIL2	
Connection size Heating/DHW (mm)		22	
DHW Expansion vessel (litres)		12	18
Charge pressure (MPa (bar))		0.35 (3.5)	
Control thermostat (°C)		80	
Pressure Relief Valve (MPa (bar))		0.3 (3.0) Contained within outdoor unit	
Control thermostat (°C)		75	
Over-temperature cut-out (°C)		80 +/- 5	
Temp/Pressure Relief Valve (°C/MPa (bar))		90 / 1.0 (10.0)	
Expansion valve (MPa (bar))		0.8 (8.0)	
Width		649	649
Depth		646	646
Height		1515	1689
Weight empty/full (kg)		54 / 204	60 / 230
Materials		Duplex stainless steel	
Vessel		Expanded polyurethane (PU)	
Insulation		50	
		1.40	1.59
Nominal thickness (mm)		50	
Standing heat loss (kWh/24h)		1.40	
Ozone Depletion Potential		zero	
Global Warming Potential		3.1	
Electrical supply		220 - 240 V ~ , 50Hz	
Phase		single	
Fuse rating - MCB Size (A)		16	
Electrical supply		220 - 240 V ~ , 50Hz	
Phase		single	
Rating (kW at 240V)		3	
Max current (A)		13	
Fuse rating - MCB Size (A)		16	
Mechanical zones		DHW and 1 heating zone*	
Optional wireless room thermostat and wireless receiver		PAR-WT50-E controller & PAR-WR51-E receiver	

*Optional 2-zone accessory pack available

Setting up the UPM3 pump

When you switch on the pump it will run to the pre-set position or the last setting. The diagram below shows the current operation status.

To change the pump setting, follow below:

- Press the '⏸' to switch to the settings view. The LEDs show the current setting for 2 seconds.
- Release '⏸' for more than 2 seconds. The user interface shows the current performance in "operation status".
- Press '⏸' for more than 2 seconds and the circulator switches to "setting selection". The LEDs flash and show the current setting mode. Please note that if the key lock is disabled, the circulator will not switch to "setting selection". In this case, unlock the key lock by pressing the button for 10 seconds.
- During a period of 10 seconds, press shortly on the '⏸' and the pump switches to the next setting.
- To select between the settings, instantly press the button until you find the setting you want. If you pass the setting, you will need to continue until the setting appears again. It is not possible to go back.
- Release '⏸' for more than 10 seconds and the user interfaces switches back to the performance view and the last setting is stored.
- Press '⏸' and the display switches to the setting view and the LEDs show the current setting for 2 seconds.
- Release '⏸' for more than 2 seconds and the user interface switches back to the performance view.

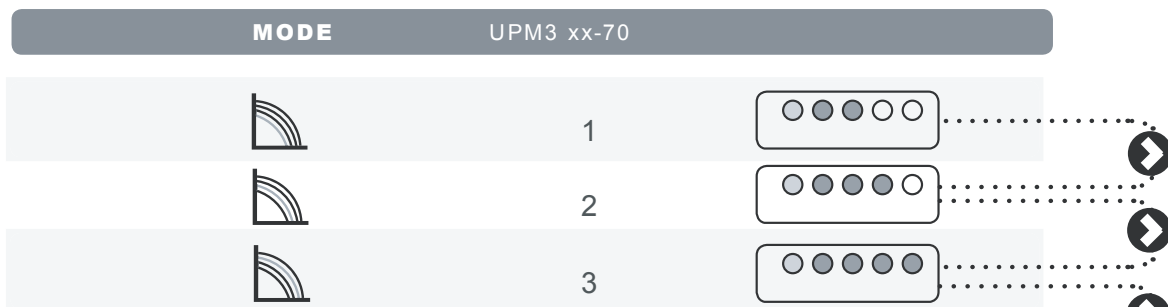
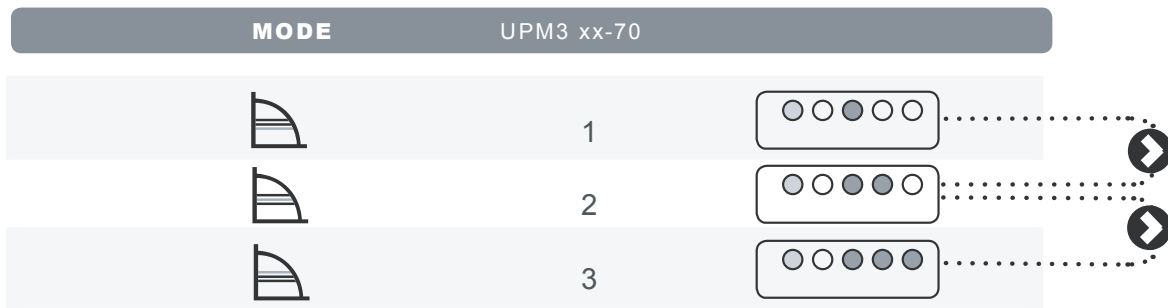
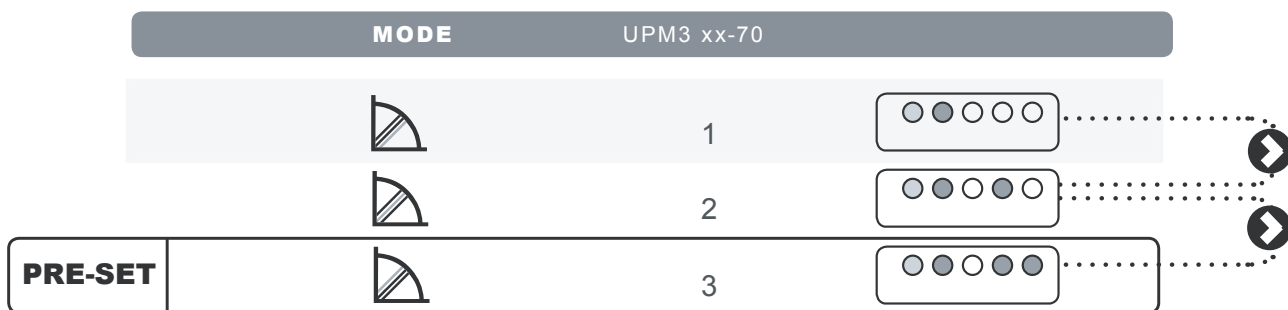



KEY
 ● Green LED
 ● Yellow LED
 ○ LED not illuminated

MAX

Control Mode explanation



Proportional pressure

The head pressure is reduced at falling heat demand and increased at rising heat demand. The duty point of the circulator will move up or down on the selected proportional pressure curve depending on the heat demand in the system.

-  PP1: lowest proportional pressure curve
-  PP2: Intermediate proportional pressure curve
-  PP3: Highest proportional pressure curve

Constant pressure

The head pressure is kept constant, irrespective of the heat demand. The duty point of the circulator will move out or in on the selected constant pressure curve, depending on the heat demand in the system.

-  CP1: lowest constant pressure curve
-  CP2: Intermediate constant pressure curve
-  CP3: Highest constant pressure curve

Constant curve

The circulator runs on a constant curve, which means that it runs at a constant speed or power.

The duty point of the circulator moves up or down the selected curve, depending on the heat demand in the system.



Constant Curve	
CC1	4 m
CC2	5 m
CC3	6 m
CC4 (max.)	7 m

Graph 1 - UPM3 performance curve

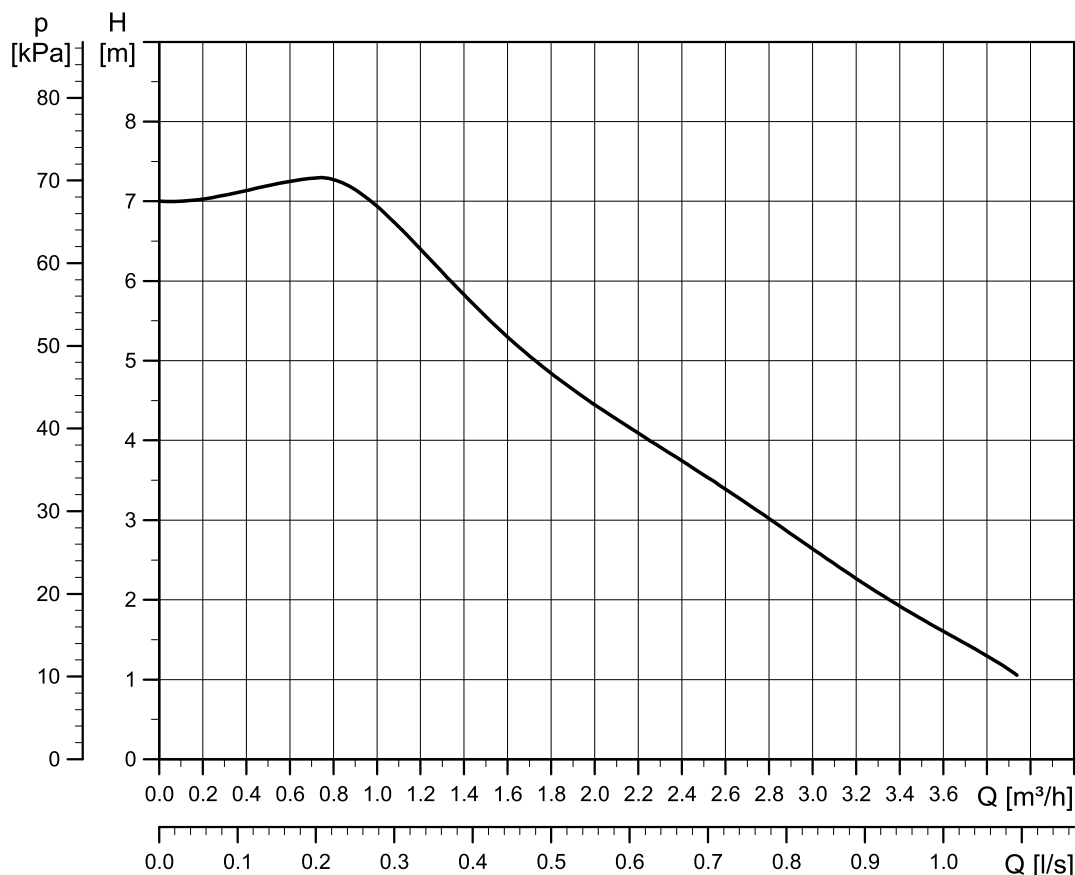

Graph 2 - UPM GEO performance curve

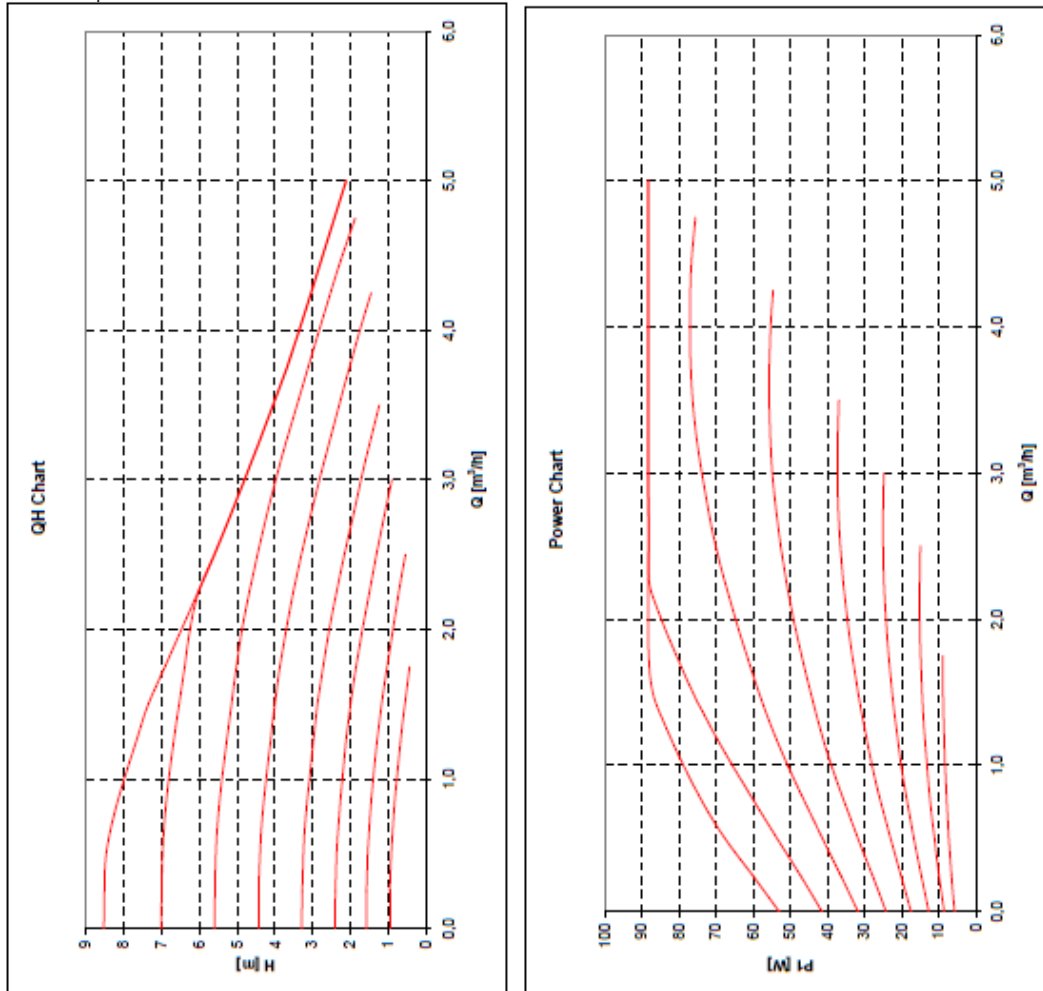

Graph 3 - UPMXL GEO performance curve

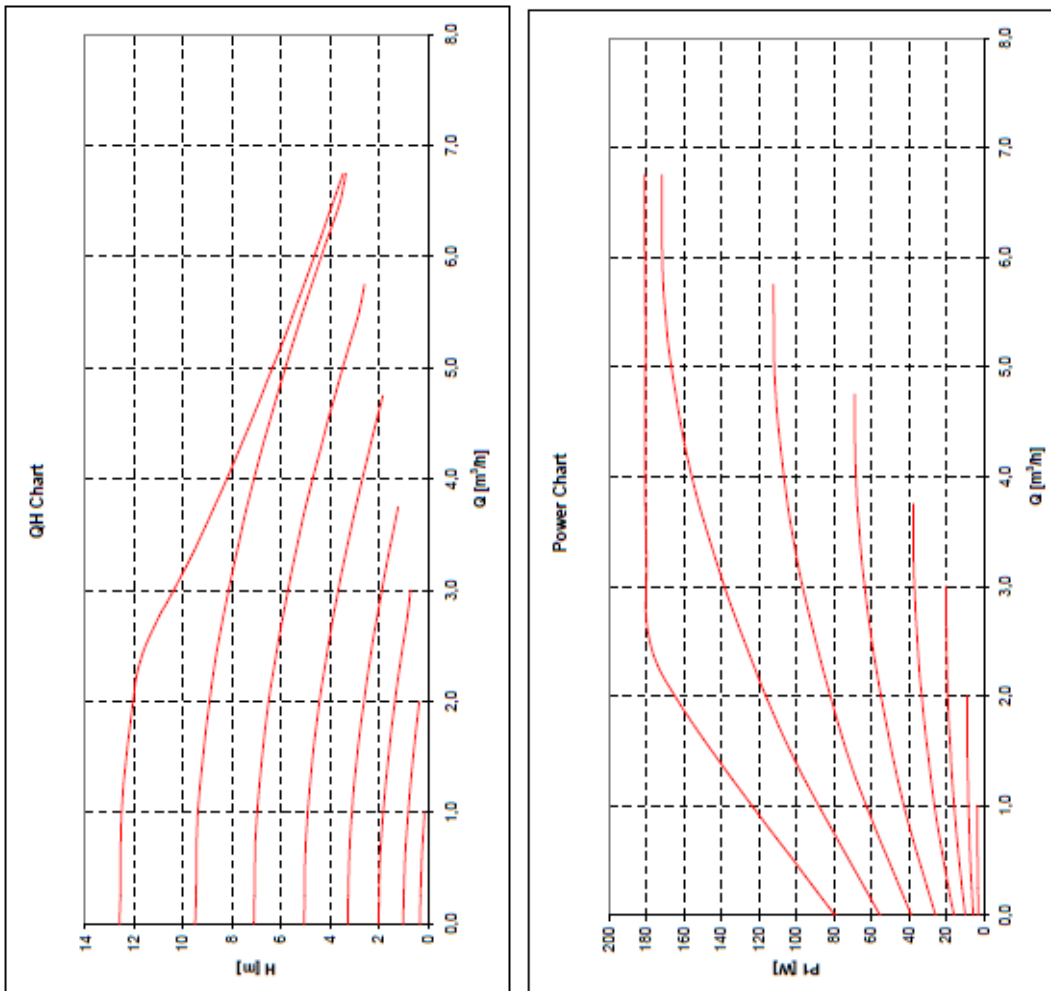

INSTALLATION – GENERAL

PIPE FITTINGS

The connection points to the heating system are in 22mm copper pipe. The use of appropriately sized COMPRESSION FITTINGS is recommended when connecting to the pipes. Solder fittings can be used, but extreme care must be taken to ensure any ancillary components in close proximity are not damaged by heat. Push fit type fittings can be used for connection to the copper pipes.

The inlet connection to the cold water combination valve is 22mm compression. The cylinder outlet fitting is suitable for connection to 22mm o/dia pipe (compression nut and olive supplied). The outlet is also threaded 3/4" BSP male parallel should threaded pipe connections be preferred.

COLD FEED

A 22mm cold water supply is recommended, however, if a 15mm (1/2") supply exists which provides sufficient flow, this may be used. More flow noise may be experienced from small bore pipes due to the increased water velocity through them.

A stopcock or servicing valve should be incorporated into the cold water supply to enable the cylinder and its associated controls to be isolated and serviced.

PRESSURE REDUCING VALVE (Fig 3 below)

The 3.5 bar pressure reducing valve can be connected anywhere on the cold water mains supply prior to the Air Source Heat Pump cylinder. There is no requirement to site it close to the unit, it can be located at a point where the mains supply enters the premises if this is more convenient but you must install a non-return valve just after the reducing valve for ease of maintenance.

PRV WARNING:

IF THERE IS AN UPSTREAM CHECK VALVE OR FITTING WHICH MAY PREVENT BACK FLOW THEN HIGH PRESSURES CAN BE EXPERIENCED DUE TO AMBIENT TEMPERATURES WHICH CAN CAUSE DAMAGE TO THE VALVES AND FITTINGS

Fig 3 - Pressure reducing valve

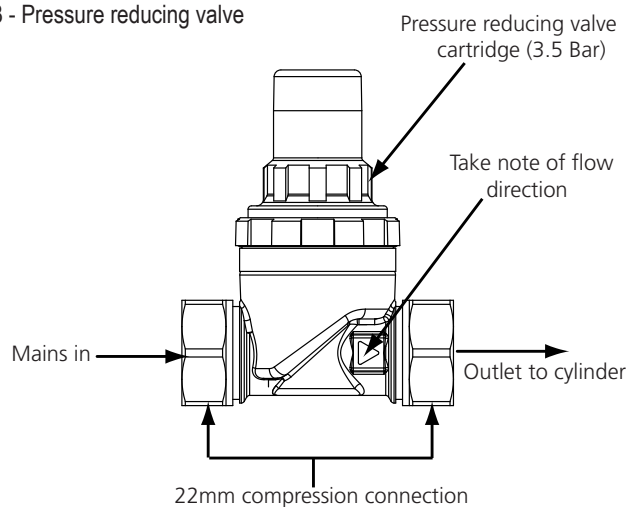
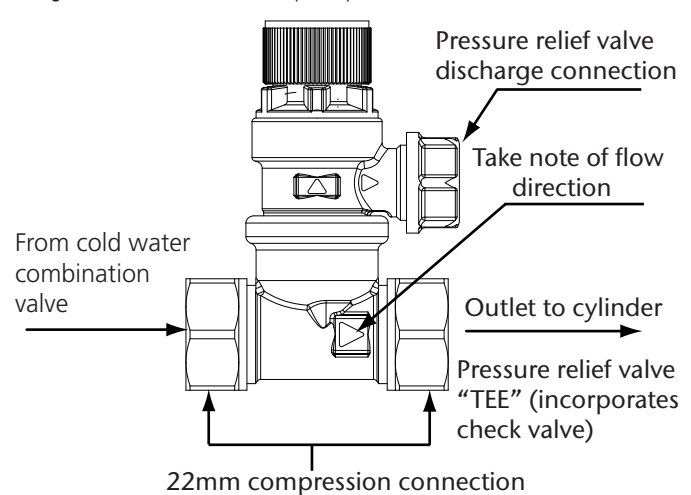

Fig 4 - Pressure relief valve (8 bar)



PRESSURE RELIEF VALVE (Fig 4 above)

Should a balanced pressure cold water supply be required to cold water outlets such as thermostatic shower mixer valves or combination taps, the cold water balanced draw off connection should be taken from between the pressure reducing valve and the pressure relief valve (see Fig 4 above). Branches to cold drinking water outlets should be taken directly from the mains supply.

EXPANSION VESSEL

The expansion vessel accommodates expansion that results from heating the water inside the unit. The expansion vessel is pre-charged at 3.5 bar. The expansion vessel must be connected between the expansion valve (see Fig. 4 above) and the cylinder by connecting it to the expansion vessel tapping on the cold feed pipe (see Fig 1 for position of tapping). The location of the expansion vessel should allow access to recharge the pressure as and when necessary, this can be done using a normal car foot pump. It is recommended that the expansion vessel is adequately supported. An expansion vessel wall mounting bracket is supplied for this purpose and should be fitted.

TUNDISH

The tundish is supplied factory fitted. Ensure it is not positioned directly over any electrical device in case any water splashes occur in the event of a safety valve discharge.

DRAIN TAPS

Drain taps are fitted to both the primary system pipe work and to the cold water inlet to facilitate draining the unit or indirect heating circuit for maintenance purposes. It is recommended that the outlet point of the drain pipe work be at least 1 metre below the level of the heater (this can be achieved by attaching a hose pipe to the drain tap outlet spigot).

HOT WATER OUTLET

Ideally the pipe work from the cylinder to the outlet fittings should be in 22mm pipe with short runs of 15mm pipe to showers and basin taps. Small bore pipe can also be used to suit some taps, but runs should be of minimum length. Pipe sizes may vary due to system design.

SECONDARY CIRCULATION

If secondary circulation is required it is recommended that it be connected to the cylinder as shown in Fig 5 below via a swept tee joint into the cold feed to the unit. **NOTE: A SECONDARY CIRCULATION CONNECTION AT THIS POINT MUST NOT BE USED ON SOLAR MODELS AS IT WILL DISTURB THE DEDICATED SOLAR VOLUME OF THE CYLINDER.**

The secondary return pipe should be in 15mm pipe and incorporate a check valve to prevent back flow. A suitable WRAS approved bronze circulation pump will be required. On large systems, due to the increase in system water content, it may be necessary to fit an additional expansion vessel to the secondary circuit. This should be done if the capacity of the secondary circuit exceeds 10 litres.

Fig 5 - Secondary circulation connection

Pipe capacity (copper):

15mm O.D. = 0.13 l/m (10 litres = 77m)

22mm O.D. = 0.38 l/m (10 litres = 26m)

28mm O.D. = 0.55 l/m (10 litres = 18m)

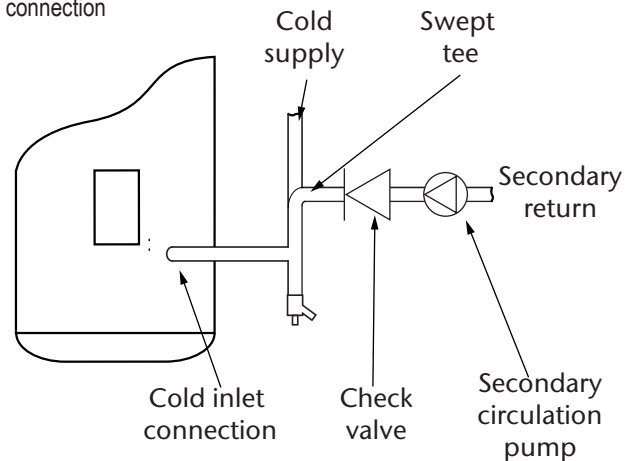

Note: 210L, 250L & 300L Standard models only have a secondary return tapping

WARNINGS

- i) Under no circumstances should the factory fitted temperature/pressure relief valve be removed other than by authorised service personnel. To do so will invalidate any guarantee or claim.
- ii) The cold water combination valve must be fitted to the mains water supply to the unit.
- iii) No control or safety valves should be tampered with.
- iv) The discharge pipe should not be blocked or used for any other purpose.

Fig 6 - T&P Relief Valve insulation

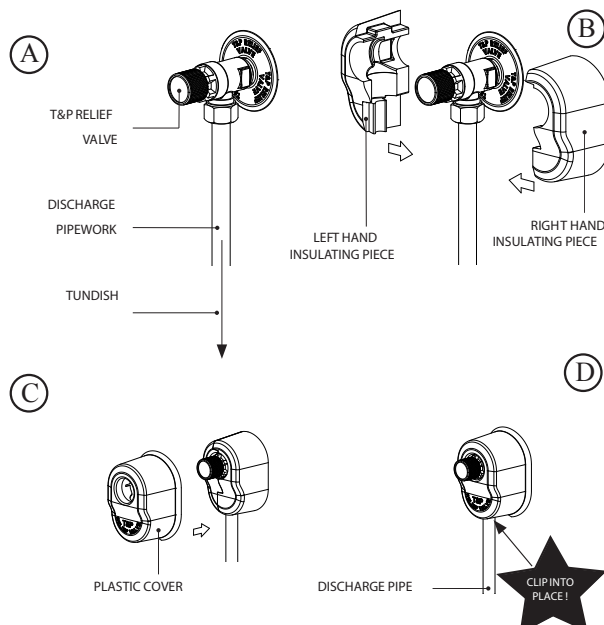
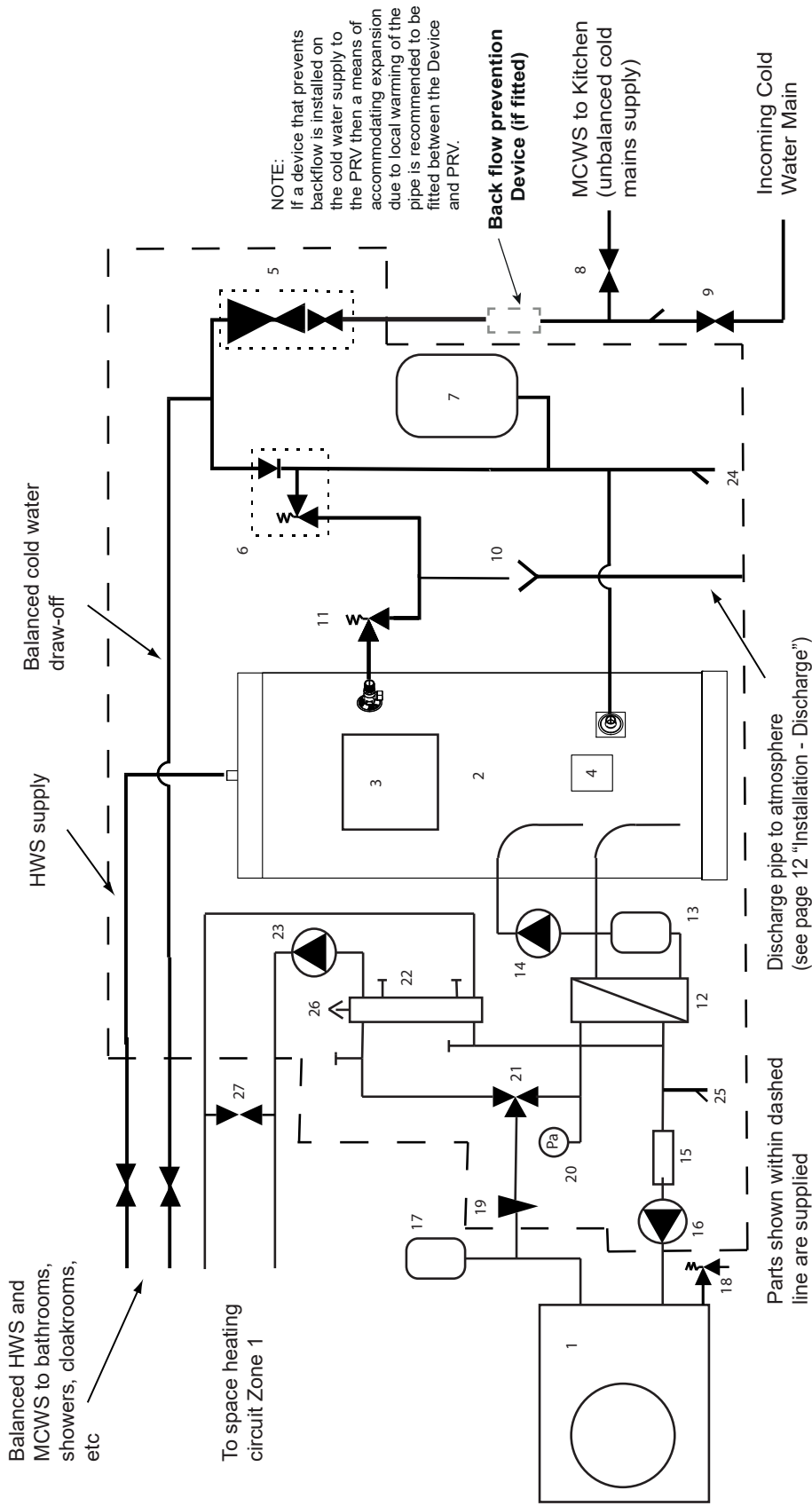

Fig 7 - Schematic installation diagram



KEY	1	2	3	4	5	6	7	8	9	10	11	12	13	14	15	16	17	18	19	20	21	22	23	24	25	26	27
	Heat Pump	Cylinder	FTC6 Controller	Immersion heater	3.5 bar Pressure reducing Valve incorporating Strainer and Check Valve (supplied loose)	8 bar Expansion Valve and Check Valve	DHW Expansion Vessel (supplied loose)	Stop Cock	Mains Stop Cock	Tundish	Temperature/Pressure relief Valve	Plate to Plate Heat Exchanger	Scale Trap	DHW Circulating Pump	Flow Sensor	Primary Pump	Primary Expansion Vessel	Primary Pressure Relief valve	Magnetic Filter	Primary System Pressure Gauge	3 Way Motorised Diverter Valve	Low Loss Header incorporating ports for 2nd heating zone and alternative heat source	Heating Pump	DHW Drainoff point	Primary circuit draw off point	Automatic Air Vent	Differential Pressure Bypass Valve (NOT supplied)

INSTALLATION - DISCHARGE

It is a requirement of Building Regulation G3 that any discharge from an unvented system is conveyed to where it is visible, but will not cause danger to persons in or about the building. The tundish and discharge pipes should be fitted in accordance with the requirements and guidance notes of Building Regulation G3. The G3 Requirements and Guidance section 3.50 - 3.63 are reproduced in the following sections of this manual. For discharge pipe arrangements not covered by G3 Guidance advice should be sought from your local Building Control Officer. Any discharge pipe connected to the pressure relief devices (Expansion Valve and Temperature/Pressure Relief Valve) must be installed in a continuously downward direction and in a frost free environment.

Water may drip from the discharge pipe of the pressure relief device. This pipe must be left open to the atmosphere. The pressure relief device is to be operated regularly to remove lime deposits and to verify that it is not blocked.

G3 REQUIREMENT

"...there shall be precautions...to ensure that the hot water discharged from safety devices is safely conveyed to where it is visible but will not cause danger to persons in or about the building."

Notes:

Discharge pipe-work D2 can now be a plastic pipe but only pipes that have been tested to a minimum 110°C must be used. Discharge pipe D2 can now be plumbed into the soil stack but only soil stacks that can handle temperatures of 99°C or greater should be used.

The following extract is taken from the latest G3 Regulations

Discharge pipe D1

3.50 Safety devices such as temperature relief valves or combined temperature and pressure and pressure relief valves (see paragraphs 3.13 or 3.18) should discharge either directly or by way of a manifold via a short length of metal pipe (D1) to a tundish.

3.51 The diameter of discharge pipe (D1) should be not less than the nominal outlet size of the safety device, e.g. temperature relief valve.

3.52 Where a manifold is used it should be sized to accept and discharge the total discharge from the discharge pipes connected to it.

3.53 Where valves other than the temperature and pressure relief valve from a single unvented hot water system discharge by way of the same manifold that is used by the safety devices, the manifold should be factory fitted as part of the hot water storage system unit or package.

Tundish

3.54 The tundish should be vertical, located in the same space as the unvented hot water storage system and be fitted as close as possible to, and lower than, the valve, with no more than 600mm of pipe between the valve outlet and the tundish (Fig. 8 & Table 5, page 23).

Note: To comply with the Water Supply (Water Fittings) Regulations, the tundish should incorporate a suitable air gap.

3.55 Any discharge should be visible at the tundish. In addition, where discharges from safety devices may not be apparent, e.g. in dwellings occupied by people with impaired vision or mobility, consideration should be given to the installation of a suitable safety device to warn when discharge takes place, e.g. electronically operated.

Discharge pipe D2

3.56 The discharge pipe (D2) from the tundish should:

- (a) have a vertical section of pipe at least 300mm long below the tundish before any elbows or bends in the pipework (see Diagram 1, G3), (Fig. 8, page 21); and
- (b) be installed with a continuous fall thereafter of at least 1 in 200.

3.57 The discharge pipe (D2) should be made of:

- (a) metal; or
- (b) other material that has been demonstrated to be capable of safely withstanding temperatures of the water discharged and is clearly and permanently marked to identify the product and performance standard (e.g. as specified in the relevant part of BS 7291-1:2006 *Thermostatic pipes and fittings for hot and cold water for domestic purposes and heating installations in buildings, General requirements*).

3.58 The discharge pipe (D2) should be at least one pipe size larger than the nominal outlet size of the safety device unless its total equivalent hydraulic resistance exceeds that of a straight pipe 9m long, i.e. for discharge pipes between 9m and 18m the equivalent resistance length should be at least two sizes larger than the nominal outlet size of the safety device; between 18 and 27m at least 3 sizes larger, and so on; bends must be taken into account in calculating the flow resistance. (See Diagram 1, Table 1, G3), (Fig. 8 & Table 5, page 21) and the worked example.

Note: An alternative approach for sizing discharge pipes would be to follow Annex D, section D.2 of BS 6700:2006 +A1:2009 *Specification for design, installation, testing and maintenance of services supplying water for domestic use within buildings and their curtilages*.

3.59 Where a single common discharge pipe serves more than one system, it should be at least one pipe size larger than the largest individual discharge pipe(D2) to be connected.

3.60 The discharge pipe should not be connected to a soil discharge stack unless it can be demonstrated that that the soil discharge stack is capable of safely withstanding temperatures of the water discharged, in which case, it should:

- (a) contain a mechanical seal, not incorporating a water trap, which allows water into the branch pipe without allowing foul air from the drain to be ventilated through the tundish;
- (b) be a separate branch pipe with no sanitary appliances connected to it;
- (c) if plastic pipes are used as branch pipes carrying discharge from a safety device they should be either polybutalene (PB) or cross linked polyethylene (PE-X) to Class S of BS 7291-2:2006 or Class S of BS 7291-3:2006 respectively; and
- (d) be continuously marked with a warning that no sanitary appliances should be connected to the pipe.

Note:

1. Plastic pipes should be joined and assembled with fittings appropriate to the circumstances in which they are used as set out in BS EN ISO 1043-1:2002 *Plastics. Symbols and abbreviated terms. Basic polymers and their special characteristics*.
2. Where pipes cannot be connected to the stack it may be possible to route a dedicated pipe alongside or in close proximity to the discharge stack.

Termination of discharge pipe

3.61 The discharge pipe (D2) from the tundish should terminate in a safe place where there is no risk to persons in the vicinity of the discharge.

3.62 Examples of acceptable discharge arrangements are:

- (b) to a trapped gully with the end of the pipe below a fixed grating and above the water seal;
- (c) downward discharges at low level; i.e. up to 100mm above external surfaces such as car parks, hard standings, grassed areas etc. are acceptable providing that a wire cage or similar guard is positioned to prevent contact, whilst maintaining visibility; and
- (d) discharges at high level: e.g. into a metal hopper and metal downpipe with the end of the discharge pipe clearly visible or onto a roof capable of withstanding high temperature discharges of water and 3m from any plastic guttering system that would collect such discharges.

3.63 The discharge would consist of high temperature water and steam. Asphalt, roofing felt and non-metallic rainwater goods may be damaged by such discharges.

Worked example of discharge pipe sizing

Fig. 8, page 23: shows a G1/2 temperature relief valve with a discharge pipe (D2) having 4 No. elbows and length of 7m from the tundish to the point of discharge.

From Table 5, page 23:

Maximum resistance allowed for a straight length of 22mm copper discharge pipe (D2) from a G1/2 temperature relief valve is 9.0m.

Subtract the resistance for 4 No. 22mm elbows at 0.8m each = 3.2m

Therefore the permitted length equates to: 5.8m

5.8m is less than the actual length of 7m therefore calculate the next largest size.

Maximum resistance allowed for a straight length of 28mm pipe (D2) from a G1/2 temperature relief valves equates to 18m. Subtract the resistance of 4 No. 28mm elbows at 1.0m each = 4.0m

Therefore the maximum permitted length equates to: 14m

As the actual length is 7m, a 28mm (D2) copper pipe will be satisfactory.

WARNINGS:

- Under no circumstances should the factory fitted temperature/pressure relief valve be removed other than by a competent person. To do so will invalidate any guarantee or claim.
- The cold water combination valve assembly must be fitted on the water supply to the Pre-plumbed cylinder.
- No control or safety valves should be tampered with or used for any other purpose.
- The discharge pipe should not be blocked or used for any other purpose.
- The tundish should not be located adjacent to any electrical components.

Table 5 - Sizing of copper discharge pipe (D2) for common temperature relief valve outlet sizes

VALVE OUTLET SIZE	MINIMUM SIZE OF DISCHARGE PIPE D1	MINIMUM SIZE OF DISCHARGE PIPE D2 FROM TUNDISH	MAXIMUM RESISTANCE ALLOWED, EXPRESSED AS A LENGTH OF STRAIGHT PIPE (i.e. NO ELBOWS OR BENDS)	RESISTANCE CREATED BY EACH ELBOW OR BEND
G 1/2	15mm	22mm 28mm 35mm	UP TO 9m UP TO 18m UP TO 27m	0.8m 1.0m 1.4m
G 3/4	22mm	28mm 35mm 42mm	UP TO 9m UP TO 18m UP TO 27m	1.0m 1.4m 1.7m
G1	28mm	35mm 42mm 54mm	UP TO 9m UP TO 18m UP TO 27m	1.4m 1.7m 2.3m

NOTE: The above table is based on copper tube. Plastic pipes may be of different bore and resistance. Sizes and maximum lengths of plastic should be calculated using data prepared for the type of pipe being used.

Fig. 8: Typical discharge pipe arrangement (extract from latest Building Regulation G3 Guidance section 3.5)

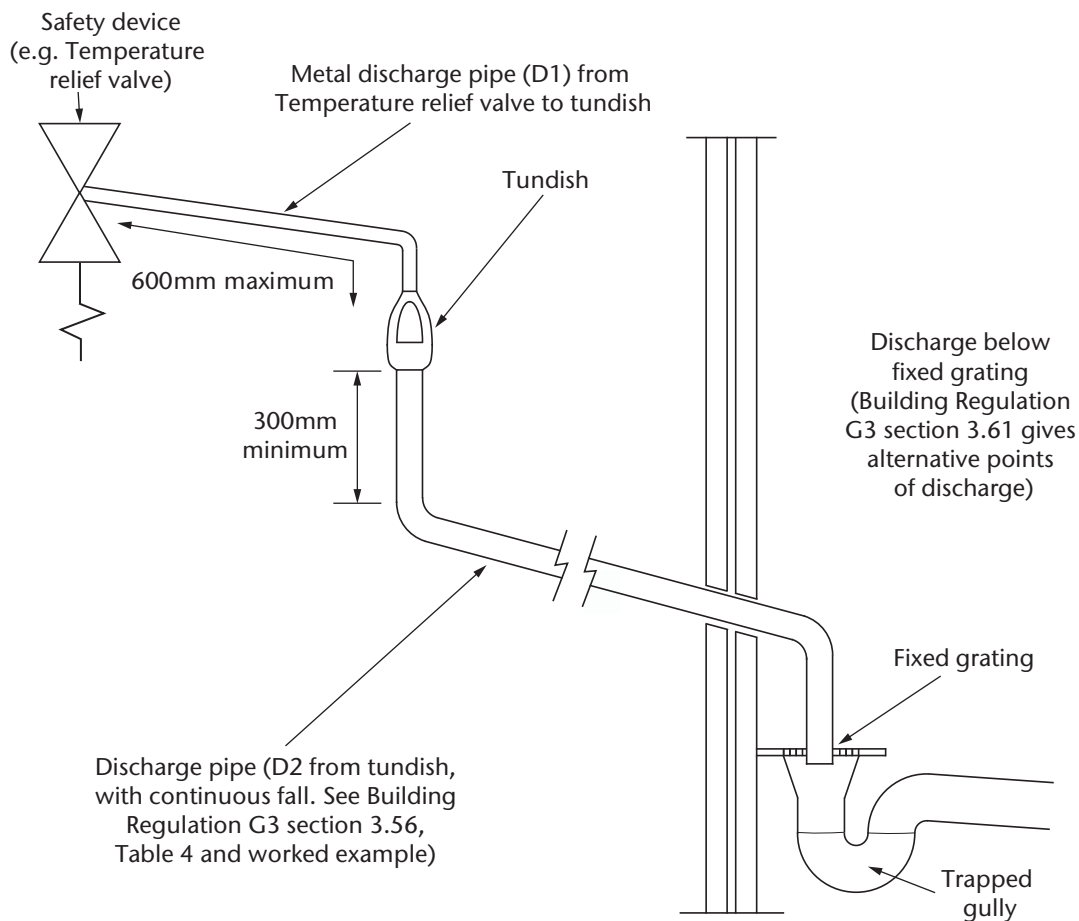

INSTALLATION - HEAT PUMP PRIMARY CIRCUIT

HEAT PUMP SELECTION

- The Pre-plumbed cylinders are suitable for use with the Mitsubishi Electric Ecodan Air Source heat pumps listed in Table 6 below
- If in doubt consult Mitsubishi Electric for further advice.
- Solid fuel boilers or any other boiler in which the energy input is not under effective thermostatic control unless additional and appropriate safety measures are installed should NOT be used.
- The primary circuit must be a sealed system type, maximum primary circuit pressure 3 bar.
- The primary flow from the heat pump MUST be pumped. Gravity circulation will not work due to the special design of the primary heat exchanger.
- The heat pump cannot be vented through the Pre-plumbed cylinder unit.

Table 6

Cylinder/HP Matrix										
Heat Pump Output kW	150Std	170Std	210Std	250Std	300Std	150Slim	170Slim	210Solar	250Solar	300Solar
5.0	x	x	x			x	x	x		
6.0	x	x	x			x	x	x		
8.5	x	x	x	x	x	x	x	x	x	x
11.2			x	x	x			x	x	x
14.0			x	x	x			x	x	x

WATER QUALITY AND SYSTEM PREPARATION

General

The water in both primary and DHW circuits should be clean and with a pH value of 6.5 to 8.0

The following values should not be exceeded in the water supply conditions:

Calcium: 100mg/L

Ca hardness: 250mg/L

Chlorine: 100mg/L

Chloride: 250mg/L

Copper: 0.3mg/L

Iron/Manganese: 0.5mg/L

Other constituents should comply with European Directive 98/83 EC

In known hard water areas, to minimise any scaling the stored DHW temperature should be restricted to 60°C

Anti-freeze

Anti-freeze solutions MUST use Propylene glycol with a toxicity rating of Class 1 as listed in the Clinical Toxicology of Commercial Products, 5th Edition

Note:

1. Ethylene glycol is toxic and MUST NOT be used in the primary water circuit in case of any cross contamination of the potable water circuit
2. For 2 zone valve ON/OFF control, Propylene glycol MUST be used

New and Existing Installations (primary water circuit)

Before connecting the outdoor unit, thoroughly cleanse the primary pipework of building debris, solder, fluxes, etc. using a suitable chemical cleansing agent.

Flush the system to remove the chemical cleanser

Add a combined inhibitor and anti-freeze solution to prevent damage to the pipework and system components.

Corrosion inhibitor should always be used.

When using chemical cleansers and inhibitors always follow the manufacturer's instructions and ensure the product is appropriate for the materials used in the water circuit.

Minimum required water volume and required primary flow rates.

Outdoor heat pump unit	Min water volume	Required flow rate
PUZ-WM50-VHA	7	14.3 L/min
PUZ-WM60-VAA	9	17.2 L/min
PUZ-WM85-VAA	12	24.4 L/min
PUZ-WM112-VAA	16	32.1 L/min
PUZ-HWM140-V(Y)HA	20	40.0 L/min

If the interlock operation primary and secondary pump is available ensure minimum water volume in primary and secondary circuit. If the interlock operation of primary and secondary pump is not available ensure minimum water volume in only primary circuit. In case of shortage of minimum water volume install a buffer tank.

MAIN CONTROLLER FLOW RATE LOOK UP

The main controller can now show you the flow rates by using Request Code 540 in the Service Menu (see FTC6 main manual).

WIRING

All electrical wiring should be carried out by a competent electrician and be in accordance with the latest I.E.E. Wiring Regulations.

The Pre-plumbed cylinder thermal controls and circulating pumps are factory pre-wired. Further wiring will be required between the FTC6 controller, the programmer, room temperature sensor and the Heat Pump. Additional controls and wiring will be required if a second CH zone is to be fitted to the installation.

Any thermal controls and over-temperature thermal cut-outs **MUST NOT** be bypassed.

The mains supply must be via a double pole isolating switch with a contact separation of at least 3mm in both poles. The supply must be fused 16 amp. A supply cable of minimum 1.5mm² cross sectional area should be used.

THIS APPLIANCE MUST BE EARTHED

HEATING SYSTEM CONTROLS

The controls provided with the Air Source Heat Pump pre-plumbed cylinder will ensure the safe operation of the unit within a central heating system.

Connection to the various system components is made via the FTC6 Controller fitted to the front of the Pre-plumbed cylinder, refer to the Manual supplied for the FTC6 Controller and the terminal identification labels within the FTC6 Controller to aid in connecting the various external system components such as the mains supply, programmer and heat pump. The wiring to the external components is made using flexible cable, this should be secured using the integral cable grips located in the FTC6 Controller.

Provision is made for the connection of a second CH zone (connections supplied blanked off). Additional controls will be necessary to control the operation of the second CH zone. Connection terminals are provided and identified in the FTC6 Controller to enable any wiring to be connected to the same central position.

Fig 9 - Optional 2 zone control pack - plumbing schematic

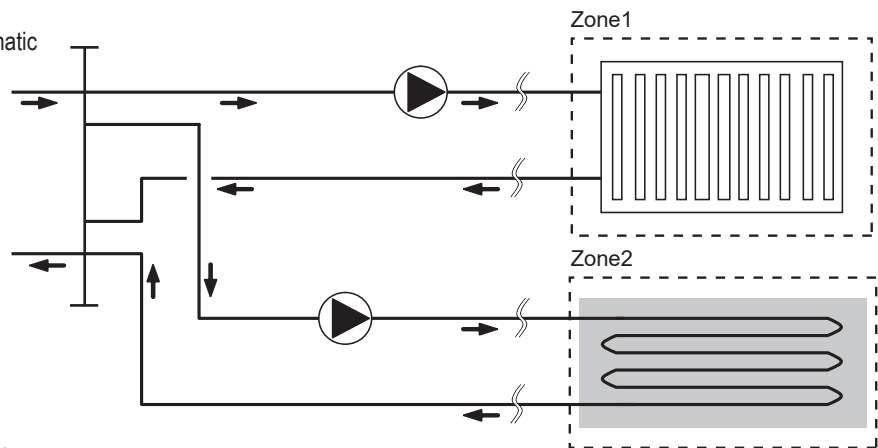

Fig 10 - Optional 2 zone control pack - component wiring

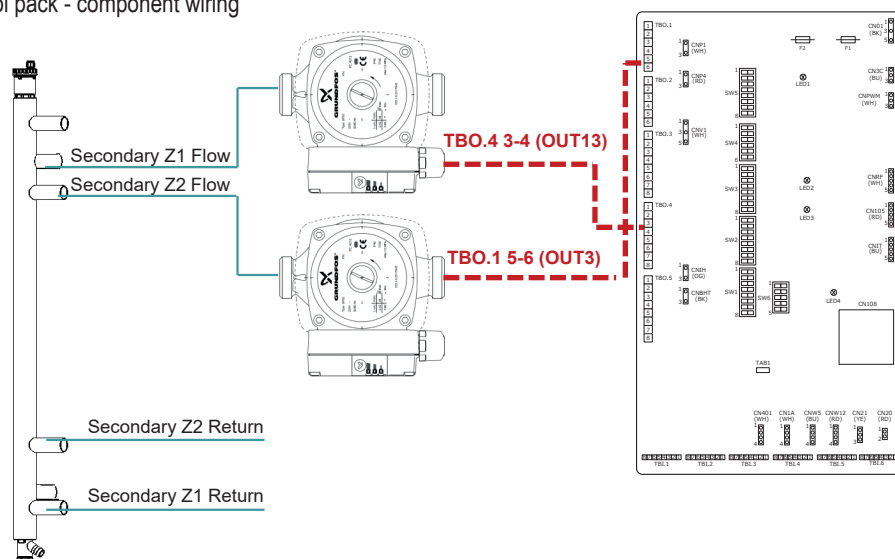

Fig 11 - Optional 2 zone control pack – dip switch settings

DIP switch	Function	OFF	ON	Default settings: Indoor unit model
SW1	SW1-1 Boiler	WITHOUT Boiler	WITH Boiler	OFF
	SW1-2 Heat pump maximum outlet water temperature	55°C	60°C	ON *1
	SW1-3 DHW tank	WITHOUT DHW tank	WITH DHW tank	OFF: PAC-IF071B-E ON : PAC-IF072/073B-E
	SW1-4 Immersion heater	WITHOUT Immersion heater	WITH Immersion heater	OFF: PAC-IF071B-E ON : PAC-IF072/073B-E
	SW1-5 Booster heater	WITHOUT Booster heater	WITH Booster heater	OFF
	SW1-6 Booster heater function	For heating only	For heating and DHW	OFF
	SW1-7 Outdoor unit type	Split type	Packaged type	OFF: PAC-IF071B-E ON : PAC-IF072/073B-E
	SW1-8 Wireless remote controller	WITHOUT Wireless remote controller	WITH Wireless remote controller	OFF
SW2	SW2-1 Room thermostat1 input (IN1) logic change	Zone1 operation stop at thermostat short	Zone1 operation stop at thermostat open	OFF
	SW2-2 Flow switch1 input (IN2) logic change	Failure detection at short	Failure detection at open	OFF
	SW2-3 Booster heater capacity restriction	Inactive	Active	OFF
	SW2-4 Cooling mode function	Inactive	Active	OFF
	SW2-5 Automatic switch to backup heat source operation (When outdoor unit stops by error)	Inactive	Active *2	OFF
	SW2-6 Mixing tank	WITHOUT Mixing tank	WITH Mixing tank	OFF
	SW2-7 2-zone temperature control	Inactive	Active *6	OFF
	SW2-8 Flow sensor	WITHOUT Flow sensor	WITH Flow sensor	OFF
SW3	SW3-1 Room thermostat 2 input (IN6) logic change	Zone2 operation stop at thermostat short	Zone2 operation stop at thermostat open	OFF
	SW3-2 Flow switch 2 and 3 input logic change	Failure detection at short	Failure detection at open	OFF
	SW3-3 —	—	—	OFF
	SW3-4 Electric energy meter	WITHOUT Electric energy meter	WITH Electric energy meter	OFF
	SW3-5 Heating mode function *3	Inactive	Active	ON
	SW3-6 2-zone valve ON/OFF control	Inactive	Active	OFF
	SW3-7 Heat exchanger for DHW	Coil in tank	External plate HEX	OFF
	SW3-8 Heat meter	WITHOUT Heat meter	WITH Heat meter	OFF
SW4	SW4-1 Multiple outdoor unit control	Inactive	Active	OFF
	SW4-2 Position of multiple outdoor unit control *7	Slave	Master	OFF
	SW4-3 —	—	—	OFF
	SW4-4 Indoor unit only operation (during installation work) *4	Inactive	Active	OFF
	SW4-5 Emergency mode (Heater only operation)	Normal	Emergency mode (Heater only operation)	OFF *5
	SW4-6 Emergency mode (Boiler operation)	Normal	Emergency mode (Boiler operation)	OFF *5
SW5	SW5-1 —	—	—	OFF
	SW5-2 Advanced auto adaptation	Inactive	Active	ON
	SW5-3 —	—	—	OFF
	SW5-4 —	—	—	OFF
	SW5-5 —	—	—	OFF
	SW5-6 —	—	—	OFF
	SW5-7 —	—	—	OFF
	SW5-8 —	—	—	OFF
SW6	SW6-1 —	—	—	OFF: PAC-IF071/072B-E ON: PAC-IF073B-E
	SW6-2 —	—	—	OFF
	SW6-3 Pressure sensor	Inactive	Active	OFF
	SW6-4 Analog output signal (0-10V)	Inactive	Active	OFF
	SW6-5 —	—	—	OFF

SW3-6 - ON



Fig 12 - Optional 2 zone twin temperature control pack - plumbing schematic

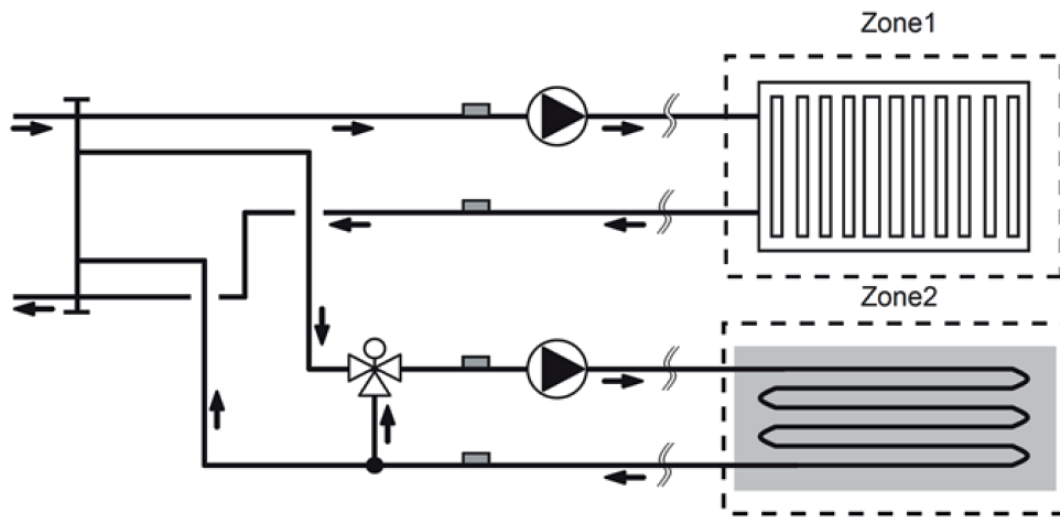

Fig 13 - Optional 2 zone twin temperature control pack - component wiring

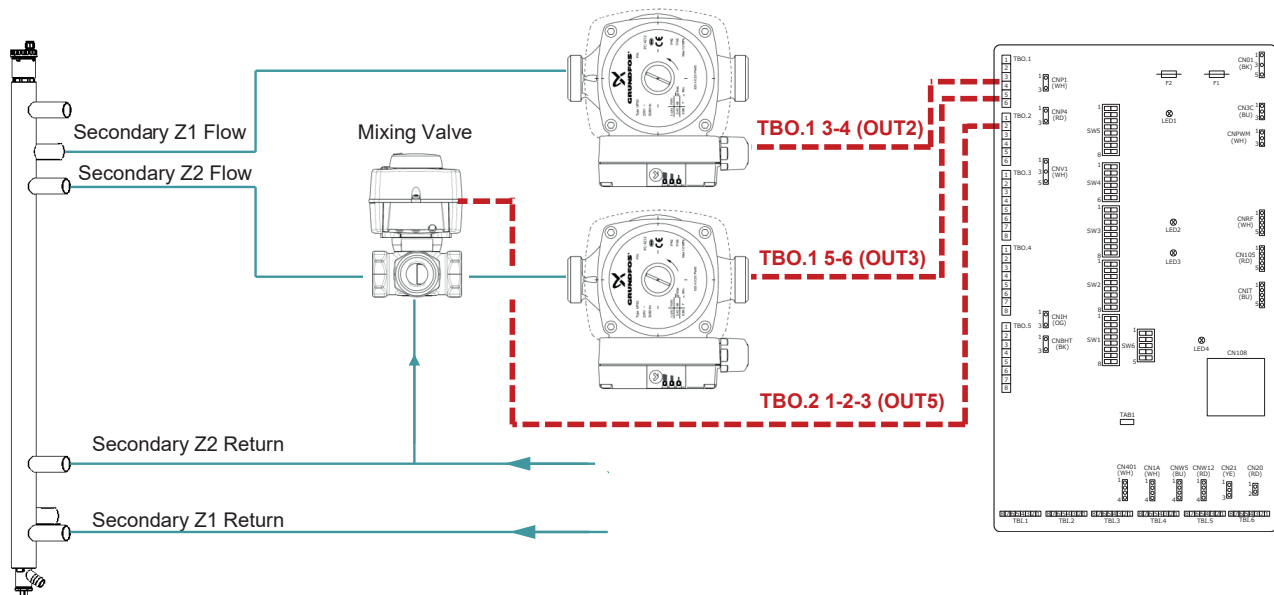

Fig 14 - Optional 2 zone twin temperature control pack - sensor wiring

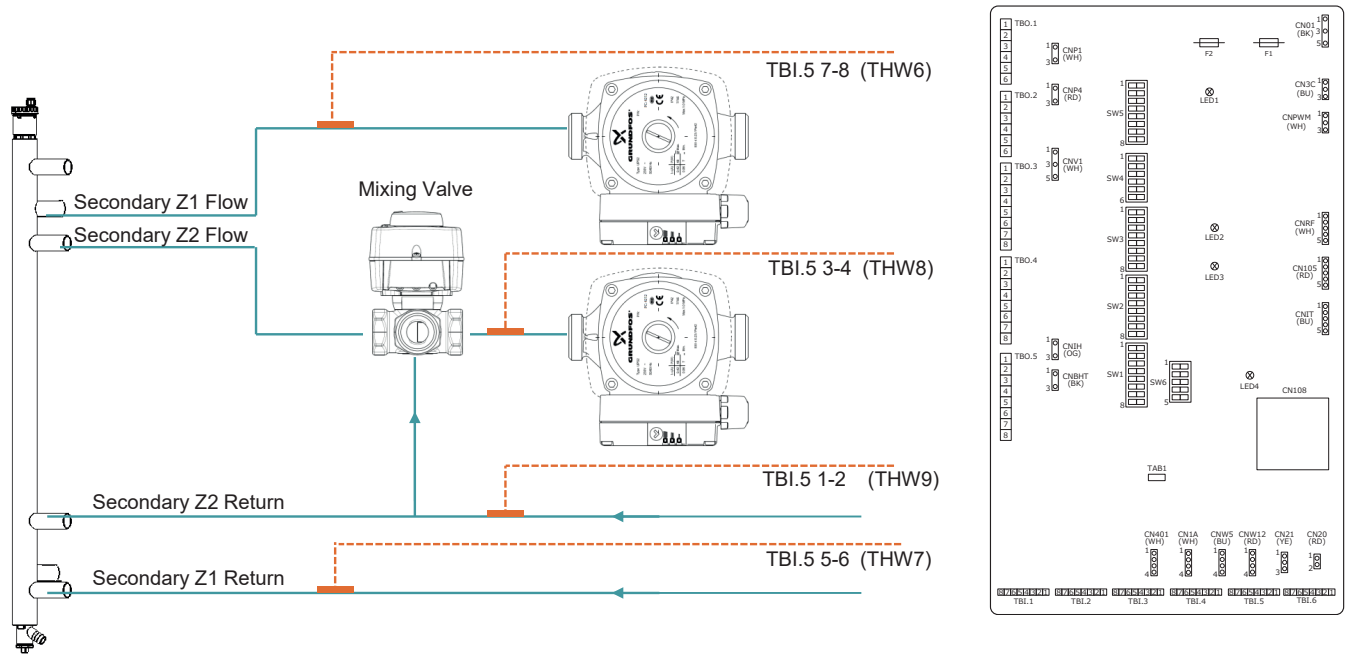

Fig 15 - Optional 2 zone twin temperature control pack - dip switch settings

DIP switch	Function	OFF	ON	Default settings: Indoor unit model
SW1	SW1-1 Boiler	WITHOUT Boiler	WITH Boiler	OFF
	SW1-2 Heat pump maximum outlet water temperature	55°C	60°C	ON *1
	SW1-3 DHW tank	WITHOUT DHW tank	WITH DHW tank	OFF: PAC-IF071B-E ON : PAC-IF072/073B-E
	SW1-4 Immersion heater	WITHOUT Immersion heater	WITH Immersion heater	OFF: PAC-IF071B-E ON : PAC-IF072/073B-E
	SW1-5 Booster heater	WITHOUT Booster heater	WITH Booster heater	OFF
	SW1-6 Booster heater function	For heating only	For heating and DHW	OFF
	SW1-7 Outdoor unit type	Split type	Packaged type	OFF: PAC-IF071B-E ON : PAC-IF072/073B-E
	SW1-8 Wireless remote controller	WITHOUT Wireless remote controller	WITH Wireless remote controller	OFF
SW2	SW2-1 Room thermostat1 input (IN1) logic change	Zone1 operation stop at thermostat short	Zone1 operation stop at thermostat open	OFF
	SW2-2 Flow switch1 input (IN2) logic change	Failure detection at short	Failure detection at open	OFF
	SW2-3 Booster heater capacity restriction	Inactive	Active	OFF
	SW2-4 Cooling mode function	Inactive	Active	OFF
	SW2-5 Automatic switch to backup heat source operation (When outdoor unit stops by error)	Inactive	Active *2	OFF
	SW2-6 Mixing tank	WITHOUT Mixing tank	WITH Mixing tank	OFF
	SW2-7 2-zone temperature control	Inactive	Active *6	OFF
	SW2-8 Flow sensor	WITHOUT Flow sensor	WITH Flow sensor	OFF
SW3	SW3-1 Room thermostat 2 input (IN6) logic change	Zone2 operation stop at thermostat short	Zone2 operation stop at thermostat open	OFF
	SW3-2 Flow switch 2 and 3 input logic change	Failure detection at short	Failure detection at open	OFF
	SW3-3	—	—	OFF
	SW3-4 Electric energy meter	WITHOUT Electric energy meter	WITH Electric energy meter	OFF
	SW3-5 Heating mode function *3	Inactive	Active	ON
	SW3-6 2-zone valve ON/OFF control	Inactive	Active	OFF
	SW3-7 Heat exchanger for DHW	Coil in tank	External plate HEX	OFF
	SW3-8 Heat meter	WITHOUT Heat meter	WITH Heat meter	OFF
SW4	SW4-1 Multiple outdoor unit control	Inactive	Active	OFF
	SW4-2 Position of multiple outdoor unit control *7	Slave	Master	OFF
	SW4-3	—	—	OFF
	SW4-4 Indoor unit only operation (during installation work) *4	Inactive	Active	OFF
	SW4-5 Emergency mode (Heater only operation)	Normal	Emergency mode (Heater only operation)	OFF *5
	SW4-6 Emergency mode (Boiler operation)	Normal	Emergency mode (Boiler operation)	OFF *5
SW5	SW5-1	—	—	OFF
	SW5-2 Advanced auto adaptation	Inactive	Active	ON
	SW5-3	—	—	OFF
	SW5-4	—	—	OFF
	SW5-5	—	—	OFF
	SW5-6	—	—	OFF
	SW5-7	—	—	OFF
	SW5-8	—	—	OFF
SW6	SW6-1	—	—	OFF: PAC-IF071/072B-E ON: PAC-IF073B-E
	SW6-2	—	—	OFF
	SW6-3 Pressure sensor	Inactive	Active	OFF
	SW6-4 Analog output signal (0-10V)	Inactive	Active	OFF
	SW6-5	—	—	OFF

SW2-7- ON

Fig 16 - Wiring of Motorised Mixing valve

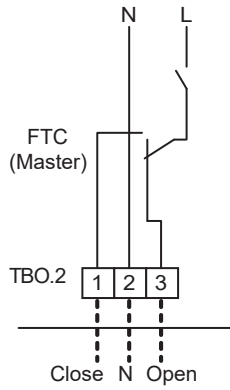

Fig 17 - Schematic of Motorised Mixing Valve hydraulic connections

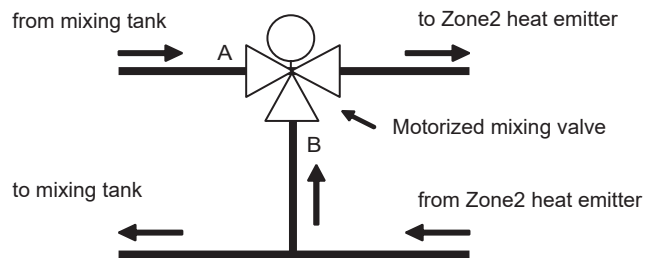
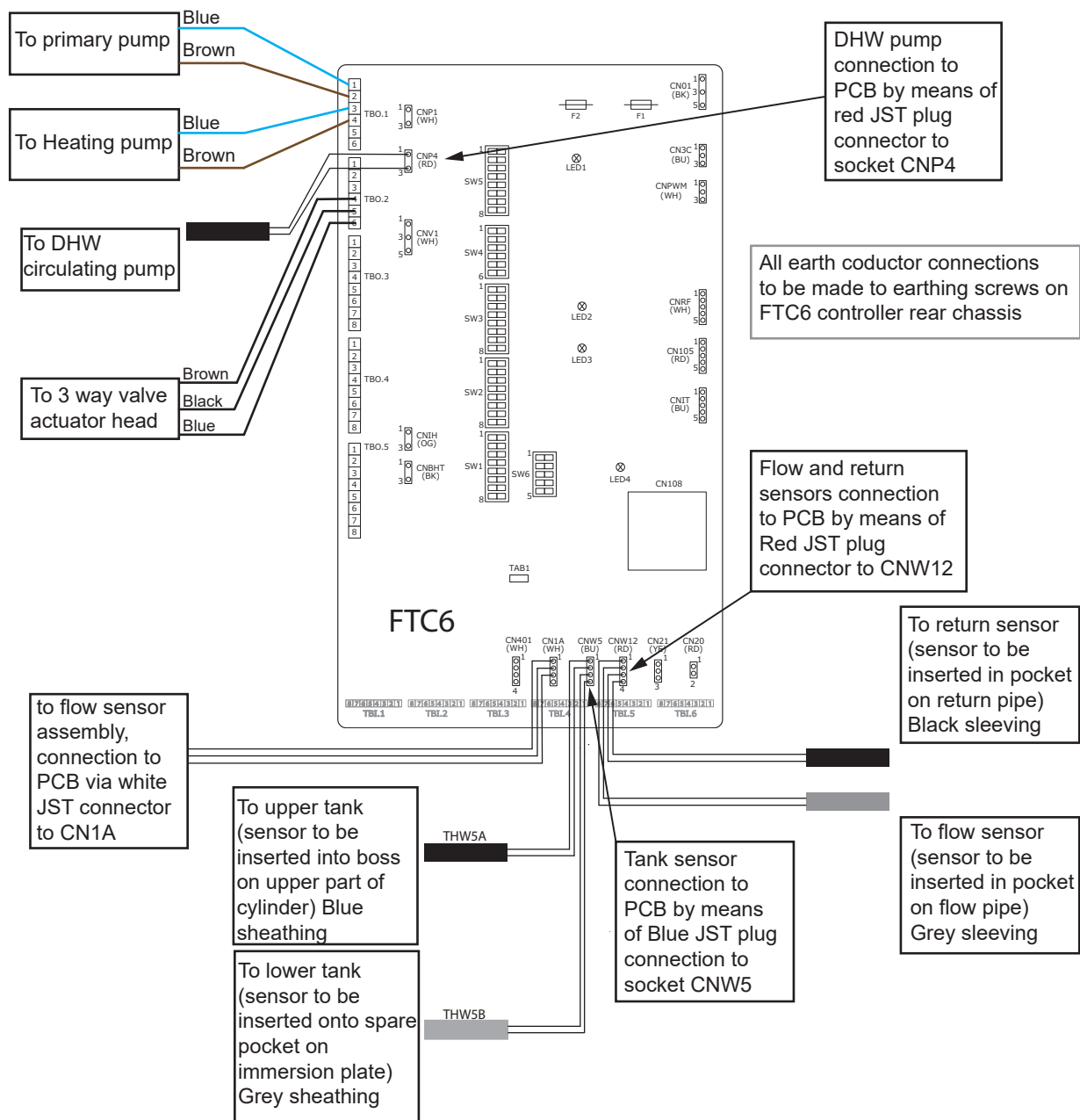

Fig 18 - Factory made connections to FTC6 controller PCB



ELECTRICAL WORK

FTC (Master) powered by independent source

If FTC (Master) and outdoor units have separate power supplies, the following requirements MUST be carried out:

- **FTC (Master) unit electrical box connector connections changed.** (see Fig. 4.1.3)
 - **Outdoor unit DIP switch settings changed to SW8-3 ON.**
 - **Turn on the outdoor unit before the FTC (Master).**
 - **Power by independent source is not available for particular models of outdoor unit model.**
- For more detail, refer to the connecting outdoor unit installation manual.

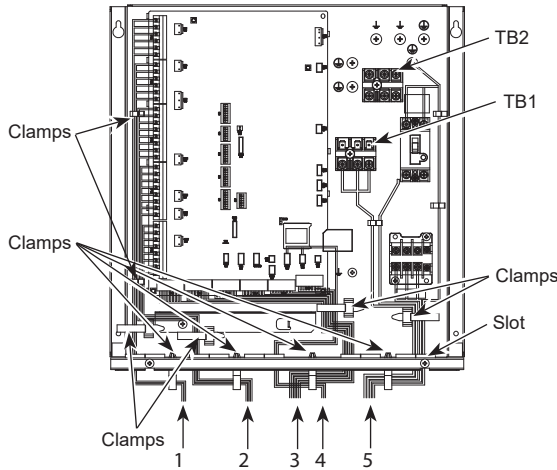

- 1 High voltage cables (OUTPUT)
- 2 High voltage cables (OUTPUT)
- 3 Low voltage cables (INPUT) and wireless receiver's cable
- 4 Thermistor cables
- 5 Power cables

Wiring for PAC-IF07*B-E

- Notes: 1. Do not run the low voltage cables through a slot that the high voltage cables go through.
 2. Do not run other cables except low voltage cables through a slot that the wireless receiver's cable goes through.
 3. Do not bundle power cables together with other cables.
 4. Bundle cables as figure above by using clamps.

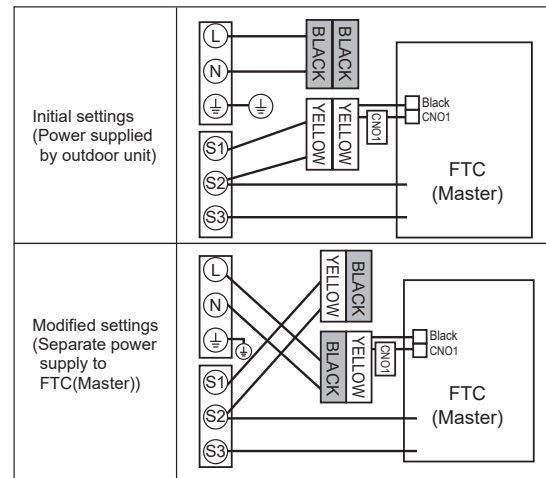

<Fig. 4.1.3>

<1 phase>

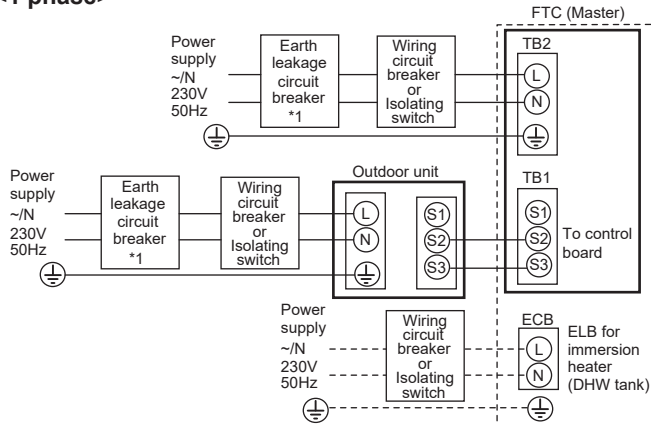

<3 phase>

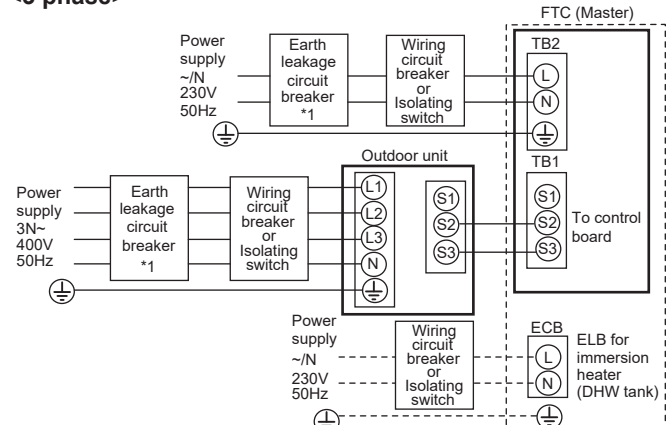

□ : PAC-IF071B-E

□ : PAC-IF072/073B-E

Electrical connections 1 phase/3 phase

*1. If the installed earth leakage circuit breaker does not have an over-current protection function, install a breaker with that function along the same power line.

A breaker with at least 3.0 mm contact separation in each pole shall be provided. Use earth leakage breaker (NV).

The breaker shall be provided to ensure disconnection of all active phase conductors of the supply.

Note: In accordance with IEE regulations the circuit breaker/isolating switch located on the outdoor unit should be installed with lockable devices (health and safety).

FTC (Master) power supply		~N 230 V 50 Hz
FTC (Master) input capacity Main switch (Breaker)		*1 16 A
Wiring No. Wiring No. × size (mm ²)	FTC (Master) power supply	2 × Min. 1.5
	FTC (Master) power supply earth	1 × Min. 1.5
	FTC (Master) - Outdoor unit	*2 2 × Min. 0.3
	FTC (Master) - Outdoor unit earth	—
Circuit rating	FTC (Master) L - N	*3 230V AC
	FTC (Master) - Outdoor unit S1 - S2	*3 —
	FTC (Master) - Outdoor unit S2 - S3	*3 24V DC

*2. Max. 120 m

*3. The values given in the table above are not always measured against the ground value.

- Notes: 1. Wiring size must comply with the applicable local and national codes.
 2. FTC (Master) unit/outdoor unit connecting cords shall not be lighter than polychloroprene sheathed flexible cord. (Design 60245 IEC 57)
 FTC (Master) unit power supply cords shall not be lighter than polychloroprene sheathed flexible cord. (Design 60227 IEC 53)
 3. Install an earth longer than other cables.
 4. Please keep enough output capacity of power supply for each individual heater. Insufficient power supply capacity might cause chattering.

ELECTRICAL WORK

Connecting inputs/outputs

For multiple outdoor units control with FTC (Slave), see section 9.

Signal inputs

Name	Terminal block	Connector	Item	OFF (Open)	ON (Short)
IN1	TBI.1 7-8	—	Room thermostat 1 input *1	Refer to SW2-1 in <5.1 DIP Switch Functions>.	
IN2	TBI.1 5-6	—	Flow switch 1 input	Refer to SW2-2 in <5.1 DIP Switch Functions>.	
IN3	TBI.1 3-4	—	Flow switch 2 input (Zone1)	Refer to SW3-2 in <5.1 DIP Switch Functions>.	
IN4	TBI.1 1-2	—	Demand control input	Normal	Heat source OFF/ Boiler operation *3
IN5	TBI.2 7-8	—	Outdoor thermostat input *2	Standard operation	Heater operation/ Boiler operation *3
IN6	TBI.2 5-6	—	Room thermostat 2 input *1	Refer to SW3-1 in <5.1 DIP Switch Functions>.	
IN7	TBI.2 3-4	—	Flow switch 3 input (Zone2)	Refer to SW3-2 in <5.1 DIP Switch Functions>.	
IN8	TBI.3 7-8	—	Electric energy meter 1	*4	
IN9	TBI.3 5-6	—	Electric energy meter 2		
IN10	TBI.2 1-2	—	Heat meter		
IN11	TBI.3 3-4	—	Smart grid ready input	*5	
IN12	TBI.3 1-2	—	Smart grid ready input	*5	
INA1	TBI.4 1-3	CN1A	Flow sensor input	*6	

*1. Set the ON/OFF cycle time of the room thermostat for 10 minutes or more; otherwise the compressor may be damaged.

*2. If using outdoor thermostat for controlling operation of heaters, the lifetime of the heaters and related parts may be reduced.

*3. To turn on the boiler operation, use the main remote controller to select "Boiler" in "External input setting" screen in the service menu.

*4. Connectable electric energy meter and heat meter

- Pulse type Voltage free contact for 12VDC detection by FTC (TBI.2 1 pin, TBI.3 5 and 7 pins have a positive voltage.)
- Pulse duration Minimum ON time: 40ms
Minimum OFF time: 100ms
- Possible unit of pulse 0.1 pulse/kWh 1 pulse/kWh 10 pulse/kWh
100 pulse/kWh 1000 pulse/kWh

Those values can be set by the main remote controller. (Refer to the menu tree in "7.2 Main remote controller".)

*5. As for the smart grid ready, refer to "4.9 Smart grid ready".

*6. Connectable flow sensor

- Power supply 5 V DC
- Measuring range 5 to 100 L/min
Those values can be set by the main remote controller. (Refer to <Auxiliary setting> on this page.)
- Flow signal 0.5 V (at minimum flow rate) to 3.5 V (at maximum flow rate)

Wiring specification and local supply parts

Item	Name	Model and specifications
Signal input function	Signal input wire	Use sheathed vinyl coated cord or cable. Max. 30 m Wire type: CV, CVS or equivalent Wire size: Stranded wire 0.13 mm ² to 0.52 mm ² Solid wire: ø0.4 mm to ø0.8 mm
	Switch	Non-voltage "a" contact signals Remote switch: minimum applicable load 12 V DC, 1 mA

Note:

Stranded wire should be processed with insulation-covered bar terminal (DIN46228-4 standard compatible type).

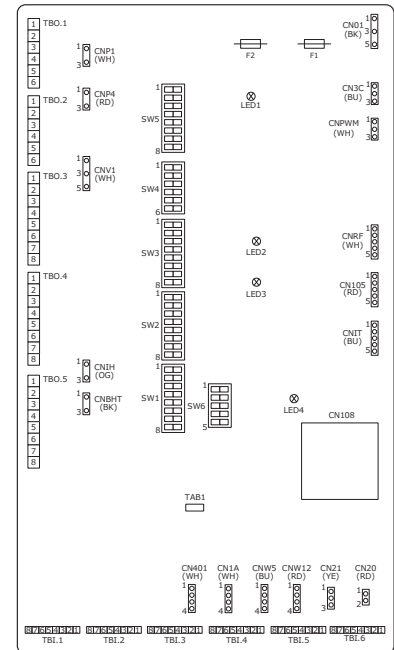

Thermistor inputs

Name	Terminal block	Connector	Item	Optional part model
TH1	—	CN20	Thermistor (Room temp.) (Option) *1	PAC-SE41TS-E
TH2	—	CN21	Thermistor (Ref. liquid temp.) *2	—
THW1	—	CNW12 1-2	Thermistor (Flow water temp.)	—
THW2	—	CNW12 3-4	Thermistor (Return water temp.)	—
THW5A	—	CNW5 1-2	Thermistor (DHW tank upper water temp.)	—
THW5B	—	CNW5 3-4	Thermistor (DHW tank water temp.)	—
THW6	TBI.5 7-8	—	Thermistor (Zone1 flow water temp.) (Option) *1	PAC-TH011-E
THW7	TBI.5 5-6	—	Thermistor (Zone1 return water temp.) (Option) *1	
THW8	TBI.5 3-4	—	Thermistor (Zone2 flow water temp.) (Option) *1	PAC-TH011-E
THW9	TBI.5 1-2	—	Thermistor (Zone2 return water temp.) (Option) *1	
THWB1	TBI.6 7-8	—	Thermistor (Boiler flow water temp.) (Option) *1	PAC-TH012HT(L)-E
THW10	TBI.6 5-6	—	Thermistor (Mixing tank water temp.) (Option) *1	

Ensure to wire thermistor wirings away from the power line and/or OUT1 to 16 wirings.

*1. The maximum length of the thermistor wiring is 30 m.

The length of the optional thermistors are 5 m. If you need to splice and extend the wirings, following points must be carried out.

1) Connect the wirings by soldering.

2) Insulate each connecting point against dust and water. Stranded wire should be processed with insulation-covered bar terminal (DIN46228-4 standard compatible type).

*2. Except PAC-IF072/073B-E.

Outputs

Name	Terminal block	Connector	Item	OFF	ON	Signal/Max. current	Max. total current
OUT1	TBO.1 1-2	CNP1	Water circulation pump 1 output (Space heating/cooling & DHW)	OFF	ON	230 V AC 1.0 A Max. (Inrush current 40A Max.)	4.0A (a)
OUT2	TBO.1 3-4	—	Water circulation pump 2 output (Space heating/cooling for Zone1)	OFF	ON	230 V AC 1.0 A Max. (Inrush current 40A Max.)	
OUT3	TBO.1 5-6	—	Water circulation pump 3 output (Space heating/cooling for Zone2) *1 2-way valve 2b output *2	OFF	ON	230 V AC 1.0 A Max. (Inrush current 40A Max.)	
OUT4	TBO.2 4-6	CNV1	3-way valve (2-way valve 1) output	Heating	DHW	230 V AC 0.1 A Max.	3.0 A (b)
OUT5	TBO.2 1-2 TBO.2 2-3	—	Mixing valve output *1	Stop	Close Open	230 V AC 0.1 A Max.	
OUT6	TBO.5 5-6	—	Booster heater 1 output	OFF	ON	230 V AC 0.5 A Max. (Relay)	3.0 A (b)
OUT7	TBO.5 7-8	—	Booster heater 2 output	OFF	ON	230 V AC 0.5 A Max. (Relay)	
OUT8	TBO.4 7-8	—	Cooling signal output	OFF	ON	230 V AC 0.5 A Max.	
OUT9	TBO.4 5-6	CNIH	Immersion heater output	OFF	ON	230 V AC 0.5 A Max. (Relay)	
OUT10	TBO.3 1-2	—	Boiler output	OFF	ON	non-voltage contact ·220 - 240 V AC (30 V DC) 0.5 A or less ·10 mA 5 V DC or more	—
OUT11	TBO.3 5-6	—	Error output	Normal	Error	230 V AC 0.5 A Max.	3.0 A (b)
OUT12	TBO.3 7-8	—	Defrost output	Normal	Defrost	230 V AC 0.5 A Max.	
OUT13	TBO.4 3-4	—	2-way valve 2a output *2	OFF	ON	230 V AC 0.1 A Max.	
OUT14	—	CNP4	Water circulation pump 4 output (DHW)	OFF	ON	230 V AC 1.0 A Max.	4.0 A (a)
OUT15	TBO.4 1-2	—	Comp ON signal	OFF	ON	230 V AC 0.5 A Max.	3.0 A (b)
OUT16	TBO.3 3-4	—	Heating/Cooling thermo ON signal	OFF	ON	non-voltage contact ·220 - 240 V AC (30V DC) 0.5 A or less ·10 mA 5 V DC or more	—
OUTA1	TBI.4 7-8	—	Analog output	—	—	0 - 10 V DC 5 mA max.	—
BC	TBO.5 3-4	—	Booster heater protection output	OFF (BHT open)	ON (BHT short)	230 V AC 0.5 A Max.	—
BHT	TBO.5 1-2	CNBHT	Thermostat for booster heater	Thermostat Normal: short	High temp. : open	—	—

Do not connect to the terminals that are indicated as “—” in the “Terminal block” field.

*1 For 2-zone temperature control.

*2 For 2-zone valve ON/OFF control.

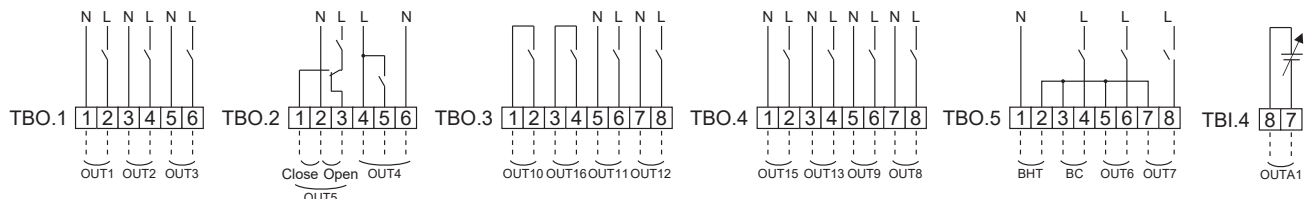

Wiring specification and local supply parts

Item	Name	Model and specifications
External output function	Outputs wire	Use sheathed vinyl coated cord or cable. Max. 30 m Wire type: CV, CVS or equivalent Wire size: Stranded wire 0.25 mm ² to 1.5 mm ² Solid wire: 0.25 mm ² to 1.5 mm ²

Note:

- When the FTC is powered via outdoor unit, the maximum grand total current of (a)+(b) is 3.0 A.
- Do not connect multiple water circulation pumps directly to each output (OUT1, OUT2, and OUT3). In such a case, connect them via (a) relay(s).
- Connect an appropriate surge absorber to OUT10 (TBO.3 1-2) depending on the load at site.
- Stranded wire should be processed with insulation-covered bar terminal (DIN46228-4 standard compatible type).

How to use TBO.1 to 5

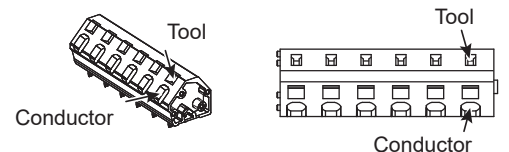

Connect them using either way as shown above.

INSTALLATION - SOLAR PRIMARY

CONNECTION TO THE SOLAR PRIMARY CIRCUIT

The lower coil of the Solar models must be connected to a fully pumped solar primary circuit. The connections are suitable for a 22mm copper pipe direct to compression fittings provided. The connections are also threaded 3/4" BSP male parallel should BSP connections be required.

The solar primary circuit must have its own dedicated circulating pump, thermal and safety controls which must be installed as per the manufacturer's instructions.

CONTROL OF SOLAR PRIMARY CIRCUIT

Temperature control of the Solar models when heated by a solar thermal system must be carried out using a suitable proprietary solar differential temperature controller. The cylinder temperature sensing probe (usually supplied with the solar differential temperature controller) should be inserted into the pocket provided on the cylinder and its cable secured using the cable clamp supplied.

The solar controller and solar primary circulation pump must be wired via the over-temperature cut-out mounted in the lower solar controls housing (see Fig 19). This will ensure that the heat input to the solar coil is interrupted in the event of the cylinder over-heating. There must also be suitable Check (non-return) valves installed in the solar primary flow and return to prevent the possibility of any thermo-syphoning if the solar circulation is stopped.

Connection to the solar differential temperature controller should be in accordance with the manufacturer's instructions. The controller should be set to give a recommended cylinder temperature of approx. 60°C otherwise nuisance operation of the thermal cut-outs may occur.

Fig 19 - Solar thermal cut-out wiring

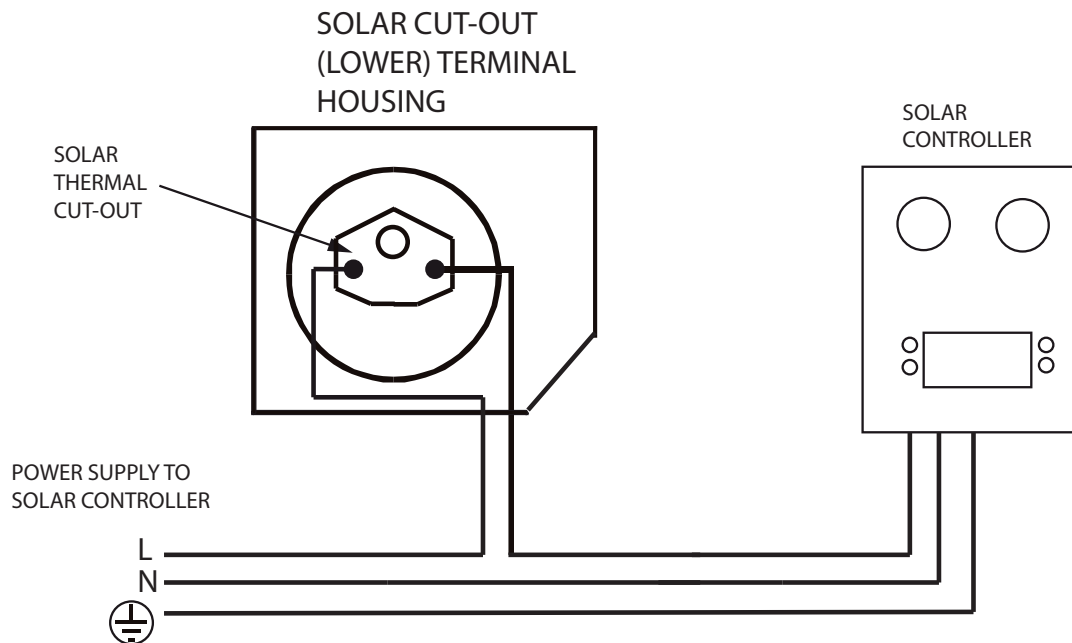

INSTALLATION - IMMERSION HEATER ELECTRICAL SUPPLY

The pre-plumbed cylinder units are supplied fitted with an immersion heater which can be used to supplement the Air Source Heat Pump heating input. The immersion heater is located within the controls housing. Refer to Fig 20 below for details of wiring of the immersion heater. **The mains supply circuit to the immersion heater must be protected by a suitable fuse and double pole isolating switch with a contact separation of at least 3mm in both poles. THE IMMERSION HEATER MUST BE EARTHED.** The supply cable for the immersion heater must be a minimum of 1.5mm² 3 core HO5 VV-F sheathed.

DO NOT BYPASS THE THERMAL CUT-OUT IN ANY CIRCUMSTANCES

Fig 20 - Immersion heater wiring

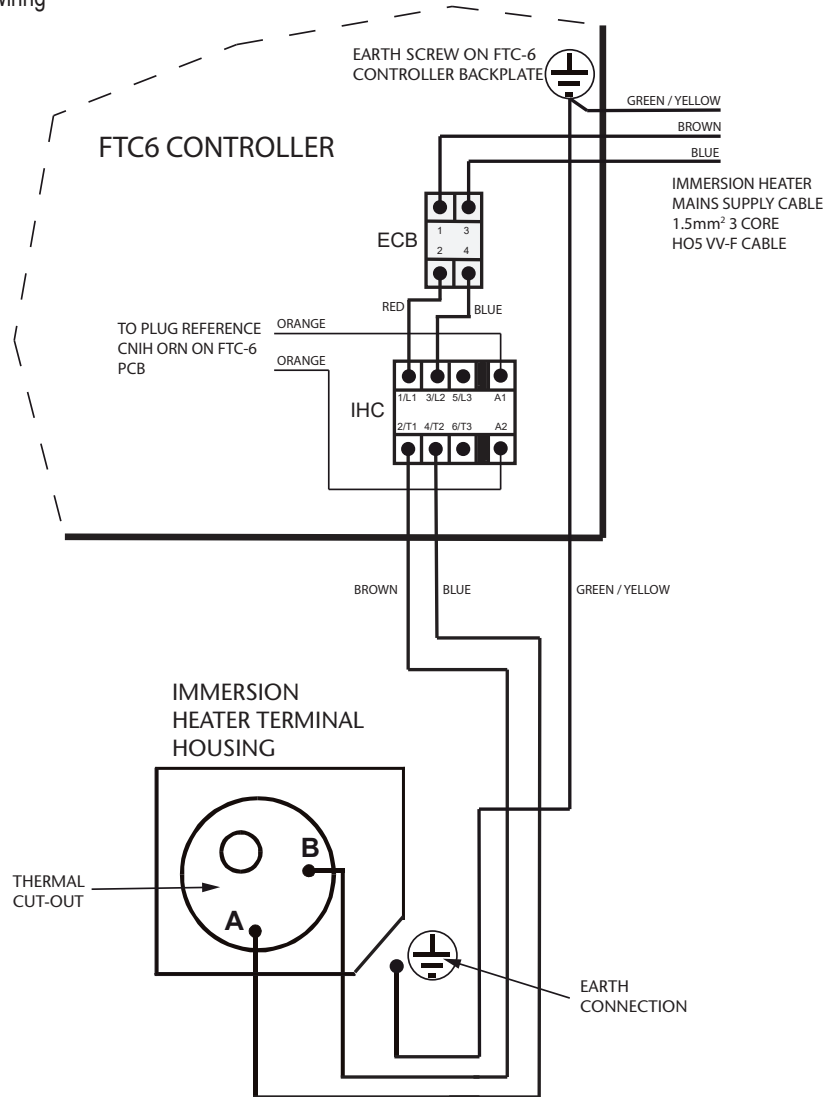

INSTALLATION - Wi-Fi ADAPTER

The pre-plumbed cylinder units are supplied fitted with a Wi-Fi adapter which can be used to easily pair your Ecodan system to the internet to enable remote control, monitoring, maintenance and technical support. The Wi-Fi adapter is pre-wired to the Mitsubishi Electric FTC controller and is contained within a transport bag at the front of the unit.

The installer must locate and mount the Wi-Fi adapter in a suitable location with good Wi-Fi signal strength (i.e. NOT within the FTC controller and not nearby automatic control devices such as automatic doors or fire alarms).

Please refer to the specific installation manual and setup quick reference guide provided. An instructional video is also available via the below QR code.



COMMISSIONING

At the time of commissioning, please ensure a Commissioning Checklist is completed for the installation.

FILLING THE UNIT WITH WATER

- BEFORE FILLING CHECK AND TIGHTEN ALL MECHANICAL JOINTS AND CONNECTIONS IN CASE THESE HAVE LOOSENED DURING TRANSIT.
- Check expansion vessel pre-charge pressure. The vessel is supplied pre-charged to 3.5 bar to match the control pressure of the pressure reducing valve. The pre-charge pressure is checked using a car tyre gauge by unscrewing the plastic cap opposite the water connection.
- Check all connections for tightness including the immersion heater(s). An immersion heater key spanner is supplied for this purpose.
- Ensure the drain cock is CLOSED.
- Open a hot tap furthest from the cylinder.
- Open the cylinder isolating valve to fill the unit. When water flows from the tap, allow to run for a few minutes to thoroughly flush through any residue, dirt or swarf, then close the tap.
- Open successive hot taps to purge the system of air.

SYSTEM CHECKS

- Check all water connections for leaks and rectify as necessary.
- Turn off water supply to the cylinder.
- Remove the Pressure Reducing Valve head work to access the strainer mesh, clean and re-fit.
- Manually open, for a few seconds, each relief valve in turn, checking that water is discharged and runs freely through the tundish and out at the discharge point.
- Ensure that the valve(s) re-seat satisfactorily.

DOMESTIC HOT WATER (DHW) CIRCULATION

Ensure the DHW circulation pump is set to speed setting II to ensure optimum DHW heating performance. Failure to do so can result in excessive use of the back-up immersion heater or lower storage temperatures than required.

PRIMARY CIRCUIT

Fill the primary circuit following the Air Source Heat Pump commissioning instructions. Vent any trapped air, If necessary, re-pressurise the system. After removing the air, automatic air vent(s) MUST be closed. Check the primary system for leaks and rectify as necessary. Flush the primary system in accordance with the instructions on Page 24 and add a suitable inhibitor and anti-freeze solution when re-filling.

Switch on the electrical supply to the Air Source Heat Pump and immersion heater. Programme the Air Source Heat Pump controller as detailed in the fitting and user instructions supplied with the controller. Set the controller for hot water operation only. After a short delay the primary pump on the return to the Heat Pump and the DHW pump should run and the Heat Pump operate. The temperature of the primary flow to the cylinder should increase, if it does not, check for a wiring or piping error.

Allow the unit to heat up.

Select the heating only function on the controller. The primary pump and the heating pump should run and the Heat Pump operates. The primary flow to the cylinder primary pipe work manifold and the radiator circuit should become hot, if it does not check for a wiring or piping error.

The minimum hot water setting is 40 °C. The maximum hot water setting is 60 °C. In hard water areas a maximum of 60 °C is recommended.

When the heating and hot water temperatures are reached, the pumps should stop running and the Heat Pump stop operating.

Check that no water is discharged from either the expansion valve or temperature and pressure relief valve during the heating cycle. If the user temperatures or "On" and "Off" times have been adjusted for commissioning purposes, the controller should be reset to the desired settings. The operation of the controller should be demonstrated to the user and the controller installation and user instructions left with them for future reference.

MAINTENANCE

MAINTENANCE REQUIREMENTS

Unvented hot water systems have a continuing maintenance requirement in order to ensure safe working and optimum performance. It is essential that the relief valve(s) are periodically inspected and manually opened to ensure no blockage has occurred in the valves or discharge pipe work. Similarly cleaning of the strainer element and replacement of the air in the expansion vessel will help to prevent possible operational faults.

The maintenance checks described below should be performed by a competent person on a regular basis, e.g. Annually to coincide with Heat Pump maintenance.

After any maintenance, please complete the relevant service interval record documentation for the installation.

INSPECTION

The immersion heater boss can be used as an access for inspecting the cylinder internally.

SAFETY VALVE OPERATION

Manually operate the temperature/pressure relief valve for a few seconds. Check water is discharged and that it flows freely through the tundish and discharge pipe work. Check valve re-seats correctly when released. NOTE: Water discharged may be very hot!

Repeat the above procedure for the expansion relief valve.

STRAINER

Turn off the cold water supply, Heat Pump and immersion heater. The lowest hot water tap should then be opened to depressurise the system. Remove the Pressure Reducing Cartridge to access the strainer mesh. Wash any particulate matter from the strainer under clean water. Re-assemble ensuring the seal is correctly fitted. DO NOT use any other type of sealant.

DESCALING IMMERSION HEATER(S)

Before removing the immersion heater, the unit must be drained. Ensure the water, electrical supply and Heat Pump are OFF before draining. Attach a hosepipe to the drain cock having sufficient length to take water to a suitable discharge point below the level of the unit. Open a hot tap close to the unit and open the drain cock to drain the unit.

IMMERSION HEATER REMOVAL

Open the cover to the immersion heater housing and disconnect wiring from immersion heater over-temperature cut-out. Remove the over-temperature cutout by pulling from the terminal connections on the immersion heater. Unscrew immersion heater backnut and remove immersion heater from the unit. A key spanner is supplied with the cylinder unit for easy removal/tightening of the backnut(s). Over time, the immersion heater gasket may become stuck to the mating surface. To break the seal, insert a round bladed screwdriver into one of the pockets on the immersion heater and gently lever up and down.

Carefully remove any scale from the surface of the element. DO NOT use a sharp implement as damage to the element surface could be caused. Ensure sealing surfaces are clean and seals are undamaged, if in doubt fit a new gasket.

Replace immersion heater ensuring the (right angled) element hangs vertically downwards towards the base of the unit. It may be helpful to support the immersion heater using a round bladed screwdriver inserted into one of the thermal control pockets whilst the backnut is tightened. Replace over-temperature cutout rod into pocket. Replace the immersion heater over-temperature cutout by carefully plugging the two male spade terminations on the underside of the thermostat head into the corresponding terminations on the element. Rewire, check, close and secure immersion heater housing cover.

EXPANSION VESSEL CHARGE PRESSURE

Remove the dust cap on top of the vessel. Check the charge pressure using a tyre pressure gauge. The pressure (with system de-pressurised) should be 0.35MPa (3.5 bar). If it is lower than the required setting it should be re-charged using a tyre pump (Schrader valve type). DO NOT OVER-CHARGE. Re-check the pressure and when correct replace the dust cap.

RE-COMMISSIONING

Check all electrical and plumbing connections are secure. Close the drain cock. With a hot tap open, turn on the cold water supply and allow unit to refill. DO NOT switch on the immersion heater or Heat Pump until the unit is full. When water flows from the hot tap, allow to flow for a short while to purge air and flush through any disturbed particles. Close hot tap and then open successive hot taps in the system to purge any air. When completely full and purged, check system for leaks. The heating source (immersion heater and Heat Pump) can then be switched on.

CLEANING THE FERNOX TF-1 COMPACT MAGNETIC FILTER

Note: There is no need to remove the cap of the TF-1 filter for cleaning

Close the isolating valves either side of the TF-1 magnetic filter. Remove the magnetic core by pulling upwards. Wait 30 seconds for any collected particles to settle in the filter body. Open the lower isolating valve then open the drain valve, collect any fluid and debris in a suitable container. Close the drain valve and open the upper isolating valve. Vent any trapped air from the filter by opening the air bleed screw on the cap. If necessary, re-pressurise the system using the filling loop fitted to the unit. After removing the air, air vent(s) MUST be closed.

Should the cap need to be removed a spanner is provided in the accessory kit for this purpose. When replacing the cap a new 'o' ring should be used, this is also provided in the kit. Air can be vented by opening the bleed screw in the centre of the air vent valve, the complete valve does not need to be removed. Should the valve be removed a replacement 'o' ring should be used (provided in accessory kit) when re-assembling. After removing the air, air vent(s) MUST be closed.

SERVICE LOG BOOK

On completion of any maintenance or service of the pre-plumbed cylinder, the Service Log Book should be filled in to record the actions taken and the date the work was undertaken.

Fig 21 - Fernox TF-1 Compact Magnetic Filter assembly

**CAUTION: CONTAINS STRONG MAGNETIC FIELDS
IF YOU HAVE AN IMPLANTED CARDIAC DEVICE EXTRA
CAUTION SHOULD BE TAKEN WHEN HANDLING THE
TF-1 COMPACT FILTER AND MAGNETIC CORE**

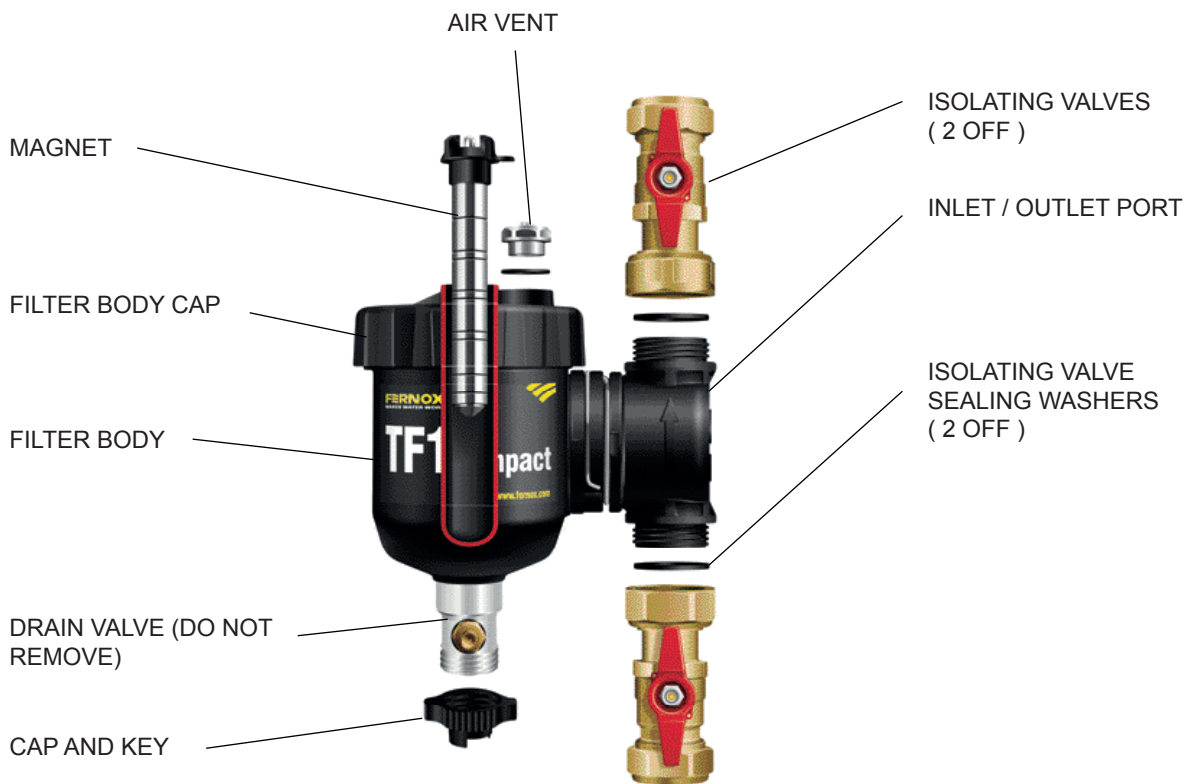

FAULT FINDING & SERVICING

IMPORTANT

- After servicing, complete the relevant Service Interval Record for the installation.
- Servicing should only be carried out by competent persons in the installation and maintenance of unvented water heating systems.
- Any spare parts used **MUST** be authorised Mitsubishi Electric parts.
- Disconnect the electrical supply before removing any electrical equipment covers.
- **NEVER** bypass any thermal controls or operate system without the necessary safety valves.
- Water contained in the Air Source Heat Pump pre-plumbed cylinder may be very hot, especially following a thermal control failure. Caution must be taken when drawing water from the unit.

Table 7 - Fault Finding Table

FAULT	POSSIBLE CAUSE	REMEDY
No hot water flow	1. Mains supply off.	2. Check and open stock cock.
	2. Strainer blocked.	2. Turn off water supply. Remove strainer and clean (see maintenance section).
	3. Cold water combination valve incorrectly fitted.	3. Check and refit as required.
Water from hot taps is cold	1. BACK UP immersion heater not switched on.	1. Check and switch on.
	2. BACK UP immersion heater thermal cut-out has operated.	2. Check. Reset by pushing button.
	3. Programmer set to Central Heating only.	3. Check. Set to Domestic Hot Water programme.
	4. Air Source Heat Pump not working.	4. Check heat pump operation. If fault is suspected, consult heat pump instructions.
	5. Thermal cut-out has operated.	5. Check. Reset by pushing button on cut-out. Check operation of DHW thermal sensor
	6. DHW circulating pump not connected correctly.	6. Check wiring and/or plumbing connections to DHW circulating pump. Check isolating valves are open
Water discharges from Expansion Valve	1. INTERMITTENTLY Expansion vessel charge pressure has reduced below 3.5bar.	1. See Maintenance section for re-charging procedure.
	2. CONTINUALLY a. Cold water combination valve pressure reducer not working correctly. b. Expansion valve seat damaged.	2a. Check pressure from cold water combination valve. If greater than 3.6 bar, replace pressure reducer cartridge. 2b. Remove expansion valve cartridge. Check condition of seat. If necessary, fit new expansion valve cartridge.
Water discharges from T&P Relief Valve	1. Thermal control failure. NOTE water will be very hot.	1. Switch off power to immersion heater(s) and /or shut down Heat Pump. DO NOT turn off water supply. When discharge stops check all thermal controls, replace if faulty.
Milky water	1. Oxygenated water.	1. Water from a pressurised system releases oxygen bubbles when flowing. The milkiness will disappear after a short while.

SPARE PARTS

A full range of spare parts are available for the Mitsubishi Air Source Heat Pump pre-plumbed cylinder range (see Table 8, page 39). Refer to the technical data label on the unit to identify the model installed and ensure the correct part is ordered. You will need to quote the serial number which is printed on the data label.

FAULT FINDING

The fault finding chart (above) will enable operational faults to be identified and their possible causes rectified. Any work carried out on this unvented water heater and its associated controls **MUST** be carried out by a competent installer for unvented water heating systems. In case of doubt contact Service Support (see contact details on back page).

WARNING

DO NOT TAMPER WITH ANY OF THE SAFETY VALVES OR CONTROLS SUPPLIED WITH THE PRE-PLUMBED CYLINDER AS THIS WILL INVALIDATE ANY GUARANTEE.

Table 8 - Spares list

	DESCRIPTION	PART NO.
1	Immersion heater (including terminal shroud and gasket)	95602002
2	Immersion heater gasket	95611026
3	Immersion heater backnut	95605204
4	Immersion heater key spanner	95605205
5	Tundish	95607881
6	Expansion Valve Cartridge 8 bar	95605206
7	Expansion Valve 8 bar Complete	95605207
8	Temperature / pressure relief valve	95605209
9	DHW Expansion vessel 12 litre (150 litre models)	95970022
10	DHW Expansion vessel 18 litre (170 and 210 litre models)	95970023
11	DHW Expansion vessel 24 litre (250 and 300 litre models)	95970024
12	Pressure Reducing Valve (3.5 bar)	95605211
13	Nut and olive pack (4 of each)	95970026
14	TSRU immersion heater over-temperature cutout	95602003
16	Heating circulating pump - UPM3	7696407
17	Primary circulating pump 150 - 210L models - UPM GEO	7696408
18	Primary circulating pump 250 & 300L models - UMPXL GEO	7696409
19	DHW circulating pump	54HSHDHW
20	Filling loop	95970029
21	Automatic air vent	95970032
22	Primary system pressure gauge	95970033
23	Drain valve	95605210
24	Terminal shroud	95970034
25	Flow sensor Body	307286
26	Flow sensor cable	307287
27	O rings for Flow Sensor body (2 per)	307288
28	Fastner clip for Flow sensor body (2 per)	307289
29	Plate to plate heat exchanger	54HSHPEX
30	Plate to plate heat exchanger insulation set	95970037
31	Terminal box cover (Standard and Solar models)	95970038
32	Terminal box cover (Slimline models)	95970039
33	Fernox TF1 magnetic filter	95970061
34	Primary pump isolating valve	95605212
35	DHW pump isolating valve	95605213
36	Scale trap assembly	95970062
37	3 way motorised diverter valve - Actuator head	54HSH3WV-ACT
38	3 way motorised diverter valve - Valve body	54HSH3WV-VLV
39	Flow temperature sensor assembly	PAC-TH011-E
40	Return temperature sensor assembly	PAC-TH011-E
41	DHW tank thermal sensor assembly	S70 C68 202
42	Solar sensor pocket assembly including gasket (Solar models only)	95970025
43	Solar thermal over-temperature cutout (Solar models only)	95970060
44	Low loss header pipe	7726888
45	Header to heat exchanger pipe	7730373
46	Inlet pipe	See table 9 page 41
47	Pump cable (not shown)	7726887

Fig 22 - Spares Diagram

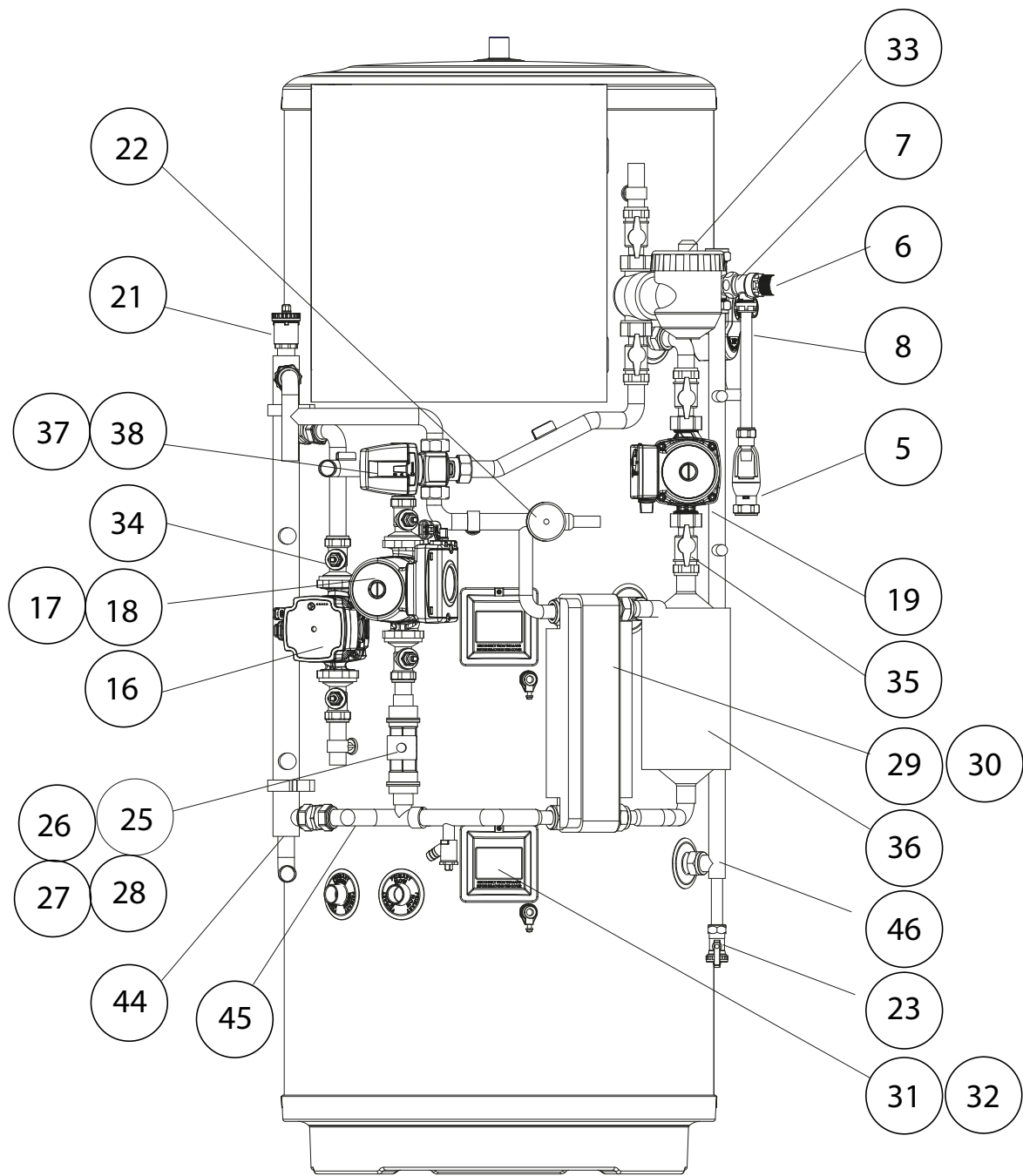

Fig 23 - Pressure Reducing valve 3.5 bar

Fig 24 - Element spares

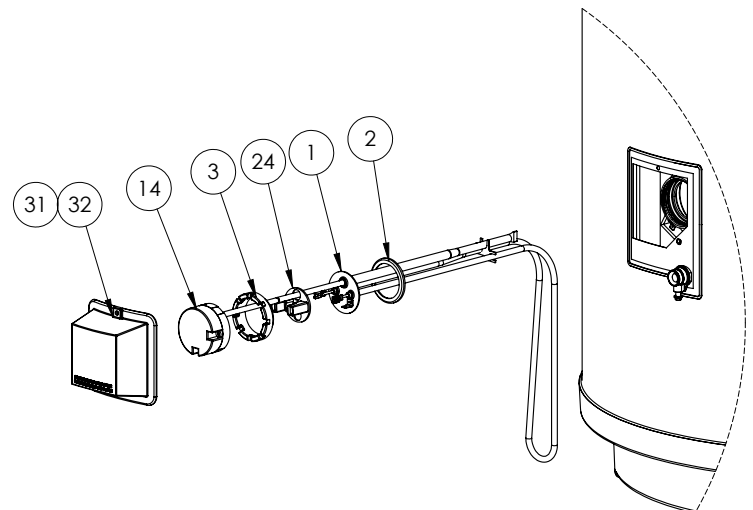
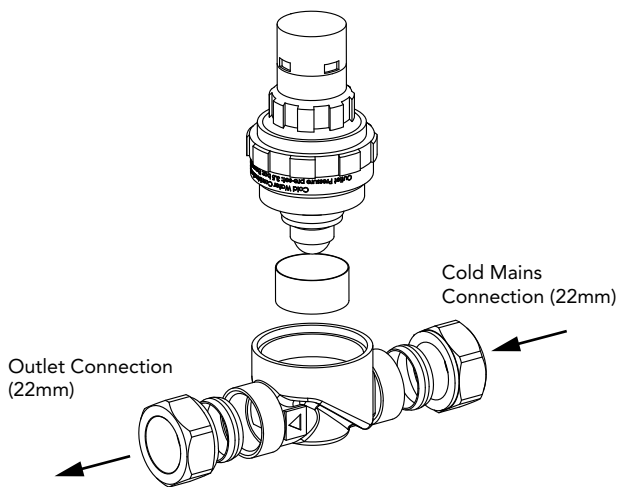

Table 9 - Inlet pipes

150 STD	7726891		150 SLIM	7726889
170 STD	7726892		170 SLIM	7726890
210 STD	7726893		210 SOLAR	7726896
250 STD	7726894		250 SOLAR	7726897
300 STD	7726895		300 SOLAR	7726898

USER INSTRUCTIONS

WARNINGS

IF WATER ISSUES FROM THE TEMPERATURE/PRESSURE RELIEF VALVE ON THE PRE-PLUMBED CYLINDER, SHUT DOWN THE HEAT PUMP AND IMMERSION HEATER. DO NOT TURN OFF ANY WATER SUPPLY. CONTACT A COMPETENT INSTALLER FOR UNVENTED WATER HEATERS TO CHECK THE SYSTEM.

DO NOT TAMPER WITH ANY OF THE SAFETY VALVES FITTED TO THE PRE-PLUMBED CYLINDER. IF A FAULT IS SUSPECTED, CONTACT A COMPETENT INSTALLER.

COMMISSIONING RECORD

Please ensure that the installer has fully completed a Commissioning Checklist and Record for the installation and that you have signed it to say that you have received a full and clear explanation of its operation. The installer is legally required to complete a commissioning checklist as a means of complying with the appropriate Building Regulations (England and Wales).

All installations must be notified to Local Area Building Control either directly or through a Competent Persons Scheme. A Building Regulations Compliance Certificate will then be issued to the customer who should, on receipt, write the Notification Number on the Commissioning Checklist.

This product should be serviced regularly to optimise its safety, efficiency and performance. The service engineer should complete the relevant Service Record document after each service.

TEMPERATURE CONTROLS IMMERSION HEATER

The hot water storage temperature is set on the Programmer, the water temperature is sensed by means of a thermistor sensor located in a pocket on the immersion heater assembly. This should be set to give a water storage temperature of approx. 55° to 60°C. The immersion heater assembly is also fitted with an over-temperature cut-out. Access to the temperature sensor and over-temperature cut-out can be made by opening the immersion heater cover - **DISCONNECT THE ELECTRICAL SUPPLY BEFORE OPENING THE COVER.**

DO NOT bypass the thermal cut-out(s) in any circumstances.

HEATING BY HEAT PUMP

The space heating control temperature and the operating times for heating and hot water are set using the remotely mounted controller. The optimum temperatures and times will have been set during commissioning. Should the temperatures or timings need to be altered, refer to the installation and user instructions leaflet supplied with the controller for the method of adjustment.

FLOW PERFORMANCE

When initially opening hot outlets a small surge in flow may be noticed as pressures stabilise. This is quite normal with unvented systems. In some areas cloudiness may be noticed in the hot water. This is due to aeration of the water is quite normal and will quickly clear.

OPERATIONAL FAULTS

Operational faults and their possible causes are detailed in the Fault Finding section (page 36) of this manual. It is recommended that faults should be checked by a competent installer.

The air volume within the expansion vessel will periodically require recharging to ensure expanded water is accommodated within the unit. A discharge of water INTERMITTENTLY from the expansion valve will indicate the air volume has reduced to a point where it can no longer accommodate the expansion.

NOTES:

NOTES:

ENVIRONMENTAL INFORMATION

Products are manufactured from many recyclable materials. At the end of their useful life they should be disposed of at a Local Authority Recycling Centre in order to realise the full environmental benefits.

Insulation is by means of an approved CFC/HCFC free polyurethane foam with an ozone depletion factor of zero.

WEEE Declaration

Disposal of Waste Equipment by Users in Private Household in the European Union.



This symbol on the product indicates that this product must not be disposed of with your other household waste. Instead, it is your responsibility to dispose of your waste equipment by handing it over to a designated collection point for the recycling of waste electrical equipment.

The separate collection and recycling of your waste equipment at the time of disposal will help to conserve natural resources and ensure that it is recycled in a manner that protects human health and the environment.

For more information about where you can drop off your waste equipment for recycling, please contact your local city office, your household waste disposal service or the company where this product was purchased.

TECHNICAL SUPPORT

Residential Heating & Ventilation Telephone: 01707 278666

MELSmart Customer Services & Support: 0161 866 6089

Option 1 - Air Conditioning Technical

Option 4 - Heating Technical

Option 2 - Spares

Option 5 - Returns

Option 3 - Warranty

Option 6 - Product Training & Site Services

Email: livingenvironmentalsystems@meuk.mee.com

Website: les.mitsubishielectric.co.uk

UNITED KINGDOM

Mitsubishi Electric Europe

Living Environmental Systems Division

Travellers Lane

Hatfield

Hertfordshire

AL10 8XB

General Enquiries

Telephone: 01707 282880

Fax: 01707 278881