

HITACHI

—
**Catalogue
2020**



Cooling & Heating



CONTENTS

Introduction	6
Yutaki Aeroheat	22
1X1 Systems	62
Multizone	104
VRF Systems	112
Outdoor units	116
Indoor units	148
Air renewal	184
Chillers	194
General conditions	218



Welcome to Hitachi Cooling and Heating, climate control solutions

—
**Over
100 years
of history
and culture**

**Japanese
technology**

**24 factories
around the
world**

**Born in Japan,
with a global
presence**

Hitachi is the global brand for premium climate control solutions, renowned for its ability to create unique spaces, understand installation requirements and meet customer demands.

By designing, engineering and manufacturing reliable, efficient, high-quality heating and cooling systems, we help people find their optimal air conditioning solution, always meeting their expectations.

Our goal is to create a world where, thanks to our cutting-edge Japanese technology, people can live in harmony with themselves, with their families, and with the environment around them.

To ensure it reaches all over the world, Hitachi has 24 factories around the globe to produce its different climate control ranges and components: residential, commercial, heating, VRF, chillers and compressors.





Hitachi's European climate control solutions factory, based in Spain

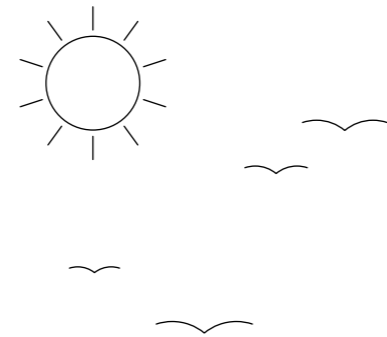

The Spanish factory in Vacarisses, Barcelona is responsible for designing, manufacturing and quality checking all climate control equipment made in Europe. It also supplies equipment to Africa, Australasia and parts of South America.

Its location within Europe means we can control the design and manufacturing process to ensure we meet the specific needs of our market. We also offer high availability of spare parts for fast replenishments.

The factory currently produces the following lines: Samurai L Chillers, VRF systems, Yutaki heat pumps, IVX commercial range and the System Free indoor units. This represents almost the entire Hitachi portfolio manufactured here in Europe for the European market.

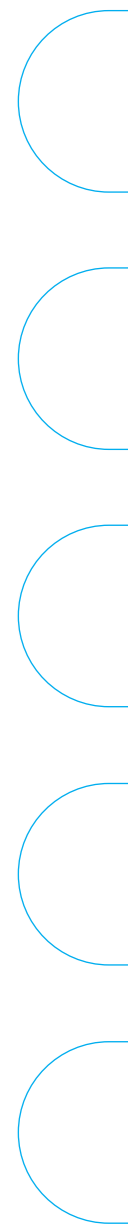
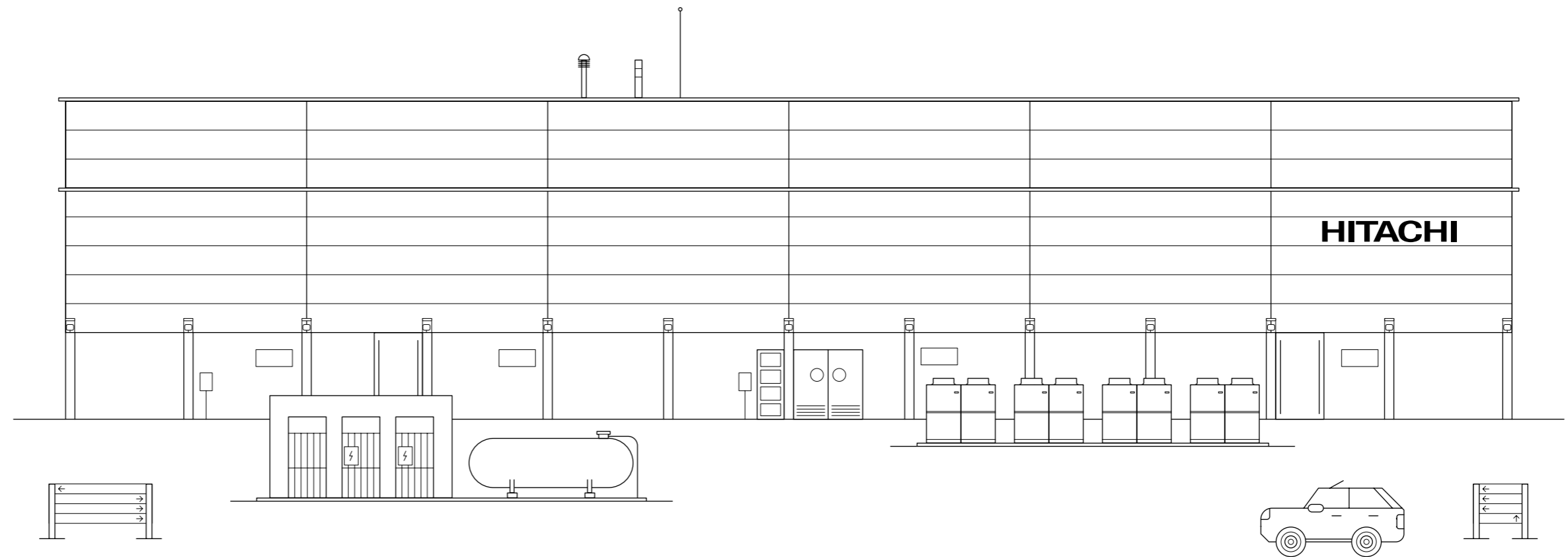

We design cutting-edge technology to meet your needs and desires



Quality you can count on

Quality guarantee

How do our products achieve this quality?

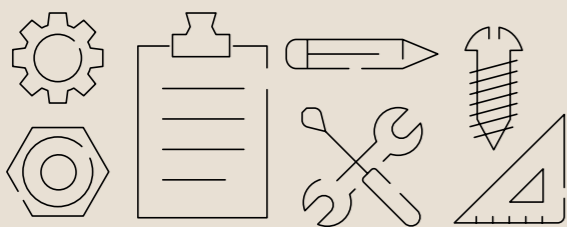

All components in our equipment are manufactured with the highest quality materials, provided by carefully selected suppliers. This guarantees the durability of our systems for lifetime climate control.

Quality assurance

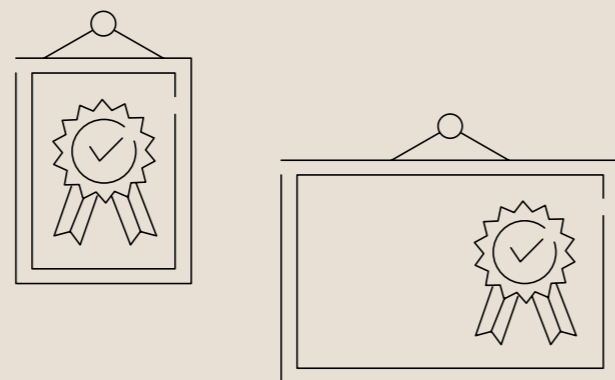

All air conditioning systems are tested one by one rather than by sampling, ensuring the required quality standards and the reliability of all our units.

We support you to support the environment

Environmental management certificate

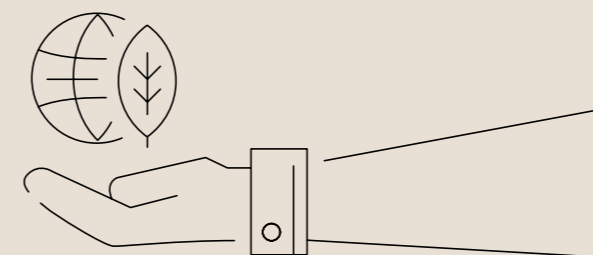

Refrigerant



Certified performance

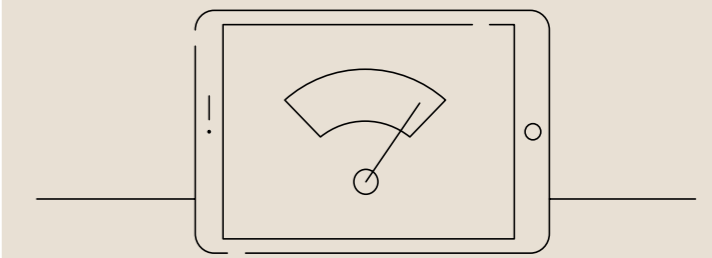

Several Hitachi ranges have the best seasonal performance on the market.

No waste goes to landfill



100% of waste generated in the factory is recycled or recovered. Our factory puts all waste to good use, helping to ensure the sustainability of the environment.

As a sign of Hitachi's commitment to the environment, many of our systems require less refrigerant to operate, making a positive contribution to both nature and society.

We're here to help you

Trusted systems with the customer service that you deserve

For product training dates and all the latest news from Hitachi, HVAC industry & renewables updates plus trends in engineering and social innovation follow us on twitter.

@hitachiairconUK

Hitachi official technical service

For fast, efficient technical help please contact our Hitachi trained engineers. They have an in-depth knowledge of the whole Hitachi range and can attend site to aid commissioning and or troubleshooting if required.

UK & Ireland Technical
(+44) 0203 901 0913
Aircon.technical@jci-hitachi.com

Spares

New European spares warehouse means most common spares available for immediate dispatch. Hi-Parts is an intuitive and simple to use online tool for spare parts enquiries and orders.

<http://www.hitachi-hvac.co.uk/apps>
(+44) 0203 901 0912
Aircon.spares@jci-hitachi.com

Warranty

Login securely, place and track warranty claims online whenever it suits you. We believe in the quality of our product and so our warranty is with the equipment and remains it with it for the duration so you and your customers can believe in it too.

<http://www.hitachi-hvac.co.uk/apps>
(+44) 0203 901 0913
Aircon.warranty@jci-hitachi.com

Standard warranty terms are:

- RAC – 3 years
- IVX Utopia, System Free, Global PAC, Sigma VRF and Yutaki – 5 years (7 available subject to terms)
- Samurai L – 3 years
- Samurai M & Samurai S – 18 months.

Free product training

We run a series of one day product specific training courses run from our aircademy training centres in Maidenhead, Dublin and Glasgow.

Contact our training team for the latest available dates.

Aircon.training@jci-hitachi.com

A variety of useful tools are available for your use from our website

<https://www.hitachi-hvac.co.uk/apps>

Hi-toolkit for home

Online selection software for air to water heat pumps for domestic applications.

Yutaki Schematics

Access to hydraulic schematics and terminal board configuration for simplified installations.

Call us on:

Tel: + 44 (0)203 901 0912
Business hours: Mon - Fri 9am - 5pm

Or send an email to:

aircon.uk@jci-hitachi.com or
aircon.ireland@jci-hitachi.com

Erp labels for Eco design

Generate energy labels for all products covered by the EcoDesign Directive, including Lot 1, Lot 2, Lot 6, Lot 10 and Lot 21 products.

Alarm Codes

24/7 Troubleshooting with explanations and error code descriptions.

BIM Library

Find BIM files of our products for your projects.

Eurovent Certification. First Japanese manufacturer to certify its products at Eurovent

Hitachi's climate control systems are Eurovent certified for full reassurance in all types of installations. Certification guarantees the performance of our systems under the most demanding conditions giving consultants, installers and end users the peace of mind that the Hitachi systems they have selected will perform as specified.



Discover the meaning of the technology icons.

We make your work selecting which units are suitable for your project easy by using technology icons to differentiate our models from each other.

Refer back to these icons to understand the unique features of each product.



Heating
This unit can operate in heating mode.



A+++
The highest possible energy class as certified by Eurovent.



Energy saving
The unit will operate in the most energy efficient way possible.



Power consumption
The consumption of your device will be displayed in heating and cooling modes.



Compatible with H-Link
The unit has an H-Link interface for connection to centralised controllers and a common communication bus.



Free Cooling
The unit uses the outside air for cooling.



External Expansion Valve
The external expansion valve can be installed away from the unit (in an adjoining corridor) in order to reduce noise.



Independent Louvre Control
Individual control of the exhaust louvres to manage the airflow.



Compatible with all System Free indoor units
Flexibility in the combination of indoor units and outdoor units.



Passivhaus Ready
Suitable for use in passive houses.



Wide operating range
Systems can perform in a wide range of ambient temperatures.



Cooling
This unit can operate in cooling mode.



Smart Cascade
Adjusts the operation automatically according to the thermal requirements.



80°C
The Yutaki S80 produces water up to 80°C.



Automatic filter cleaning
Integrated filter self-cleaning robot.



4 Way Swing
For ideal air distribution, the air can be distributed in 4 different directions.



External Pressure
Adaptive pressure that allows installation with different sizes and lengths of ducts.



Constant air flow
The fan motor adjusts the air pressure whilst maintaining a constant air flow.



Adaptable
Change the air outlet easily depending on installation requirements.



Independent Control
Control the individual temperature from each indoor unit.



Air Curtain
Compatible with a range of commercially available air curtains.



R32
Equipment uses new sustainable R32 refrigerant.



Hot water
Produces hot water for your house.



ECO-Motion sensor
Detects movements in the room and adjusts the operation of the unit to save energy.



Hi-Kumo
Compatible with the control app from Hitachi.



7 day schedule
Program the units operation for a whole week.



CO2-Sensor
Control the air quality with connection to CO2-Sensors.



Compact
The cassette panel fits perfectly into a standard ceiling tile.



Guaranteed comfort
The new louvres guarantee the best comfort for users.



Independent louvres control
Amend the louvre direction to adjust the air flow.



Energy Recovery
Produces hot water for free by the use of heat recovery.



Product Certification
Eurovent and Keymark certification ensure products are tested to the highest standards in Europe for piece of mind installations.



Reduced dimensions
Compact and lightweight equipment for easier more aesthetic installations.



Renewable technologies
Climate friendly solutions without direct CO2 emissions.



Silent
Unit has very quiet operation.



Energy Class
Unit meets the high requirements of EU directives.



Integral H-Link
Integrated H-link control protocol and ability to connect to central controls.



Multizone compatibility
Indoor unit is compatible with Multizone outdoor units.



Exclusive to Hitachi
Unique and exclusive products to Hitachi.



Smooth Drive
Compressor speed is regulated in steps of 0.1Hz. This enables pinpoint accuracy in power control and comfort.



Heat pump or Heat recovery
Units can be used as either 2 pipe heat pumps or as 3 pipe heat recovery systems with CH boxes.



High H Speed
An extra speed setting has been added to make 4 in total. Ideal for applications with high ceilings.



















New to Hitachi
Discover Hitachi's latest range of innovative products.















Frost Wash
Automatic cleaning of the heat exchanger in the indoor unit for fresher air.







New products for 2019

RAC

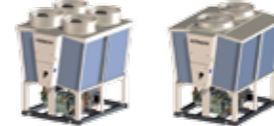







R32 PREMIUM WALL Exclusive design and features to meet new market opportunities	RAK-PSE(W/S) 2.5~5.0kW  
	RAC-WSE 2.5~5.0kW  
R32 STANDARD WALL The most discreet and flexible unit on the market	RAK-(Q/R)PE 1.5~5.0kW  
	RAC-WPE 1.5~5.0kW  
R32 HI-END WALL Economic heating solution with a differentiated design	RAK-(Q/R)XE 1.8~5.0kW  
	RAC-WXE 1.8~5.0kW  
R32 HI-END FLOOR Exclusive design and high performance to match end-user requirements	RAF-RXE 2.5~5.0kW  
	RAC-FXE 2.5~5.0kW  

R32 DUCTED Wide, complete and consistent range to match all applications	RAD-(Q/R)PE 2.0~7.0kW  
	RAC-NPE 2.0~7.0kW  
R32 CASSETTE Wide complete and consistent range to match light commercial applications requirements	RAI-RPE 2.5~6.0kW  
	RAC-NPE 2.5~6.0kW  
R32 MULTI SPLIT One of the widest R32 multi ranges on the market	RAM-NP-E 3.3~10.6kW  
MULTI + YUTAMPO The first multi on the market providing triple comfort heating, cooling and domestic hot water Tanks available in 190 litre & 270 litre* <small>* Hot water tank shown is not currently available in the UK</small>	RAM-90NYP5B 8.5 kW 
CONTROLS	
HI-KUMO PRO An intuitive web platform to remotely check the status of Hitachi units from anywhere	
A platform dedicated to remote maintenance for professionals	

CHILLER

SAMURAI (AH2-WH1 SERIES) Now with improved expanded options	R(C/H)ME 60-140AH2 60.0~140.0HP 
	RCME 40-70WH1/CLH1 40.0~70.0HP 
SAMURAI S Modular DC Inverted heat pump	RHMA 4-7AVN 4.0~7.0HP 
SAMURAI M Hybrid chiller combining the best of monobloc and modular flexibility	R(C/H)MA 18-24AN 18.0~24.0HP 
	R(C/H)MA 90-100AN 90.0~100.0HP 
PAC / VRF	
SIDE FLOW VRF The first side flow VRF on the market providing simultaneous heat pump and heat recovery from 22.4 to 33.5 Kw	RAS-FS(V)NME 12.1~15.5kW 
	RAS-FSXNME 24.4~33.5kW 

HEATING

YUTAKI S Environmentally friendly refrigerant within a versatile heat pump range Widest range on the market	RWM-2.0~3.0NRE 2.0~3.0HP  
YUTAKI S COMBI The all-in-one compact product, best seller of the heating range Best in class performances for new housing market Solar version, standard version	RWD-2.0~3.0NRW(S) E-(200/260)S(-K) 2.0~3.0HP  
YUTAKI M Plug and Play solution requiring no indoor space Operating range improved for R32 models	RASM-2-3VRE 2.0~3.0HP  
CONTROLS	
WIRED REMOTE CONTROLS Wired individual controllers with new functions <ul style="list-style-type: none"> - Energy saving modes - Frost protection - Power consumption estimation - Comfort functions (gentle cool / off coil control) 	PC-ARH1E 
	PC-ARFP1E 
HI-KUMO PRO An intuitive web platform to remotely check the status of Hitachi units from anywhere A platform dedicated to remote maintenance for professionals	

To find out more about Hitachi's new products contact your Area Sales Manager or call Hitachi Direct Sales on 020 3901 0912

The Yutaki range is part of the product group known as air source heat pumps, systems that use the latent heat in ambient air to generate energy and provide all the heating and hot water needs in the home.

Begur Son Rich housing development, air conditioned with Hitachi's Yutaki air to water heat pumps



Yutaki Air to water heat pumps



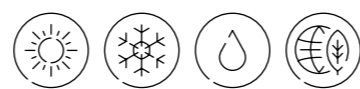

Yutaki S



Yutaki S Combi



Yutaki S80



Yutaki M



Yutaki T



Quick selection table

	Yutaki S	Yutaki S Combi	Yutaki S80	Yutaki M	Yutaki T
	Heating, cooling and hot water	Heating, cooling and hot water	Heating and hot water	Heating, cooling and hot water	Hot water
Range	RWM-2~10 NE	RWD-2~6 NW(S)E - (200/260)K(S)	RWH-4~6 (V)NF(W)E	RASM-3~6(V)NE	TAW-(190/270)NHB
Applications	Low temperature radiators, underfloor heating, fan coil, hot water and pool heating. Ideal for new builds and for replacing wall-mounted boilers.	Low temperature radiators, underfloor heating, fan coil, built-in hot water and pool heating. Ideal for homes with little space, thanks to the integrated hot water tank.	High and/or low temperature radiators, underfloor heating, fan coil (heat-only), hot water and pool heating. Ideal for installations requiring high temperatures, e.g. replacing diesel boilers.	Low temperature radiators, underfloor heating, fan coil, hot water and pool heating. Compact unit, ideal for installations with little indoor space.	Hot water production.
Heating capacity kW (built-in min/max)	1.85 - 32.00	1.85 - 17.80	4.30 - 17.80	2.10 - 17.80	—
COP up to 7 °C out/ 30 - 35 °C water	5.25	5.25	5.00	5.00	3.20
Cooling capacity (built-in min/max)	3.80 - 20.60	3.80 - 13.70	—	6.00 - 13.70	—
EER up to 35 °C out/ 7 - 12 °C water	3.54	3.54	—	3.54	—
Production temperature (up to) °C	60	60	80	60	—
Heating operating range °C	-25 ~ 25	-25 ~ 25	-25 ~ 25	-25 ~ 25	—
Cooling operating range °C	10 ~ 46	10 ~ 46	—	10 ~ 46	—
Domestic hot water operating range °C	-25 ~ 35	-25 ~ 35	-25 ~ 35	-25 ~ 35	-15 ~ 37
Compressor	Scroll DC Inverter	Scroll DC Inverter	Scroll DC Inverter	Scroll DC Inverter	Rotary
Efficiency	A+++	A+++	A+++	A+++	—



Benefits

Yutaki air to water heat pumps

1 Your needs change, Yutaki adapts

The day to day needs of your customers will change from heating in winter to cooling in summer and sanitary hot water water all year round. They may want to connect solar panels and heat their swimming pools. It's therefore important to have a system able to meet all these needs; able to connect to any style of emitter, new or existing: radiators, underfloor or fan coils.

Able to supply two different zones with different flow temperatures simultaneously such as underfloor downstairs and radiators upstairs.

2 Renewable energy, guaranteed savings



Air source heat pumps are considered one of the most energy efficient technologies around, on account that they produce more energy in heat than they consume in electricity.

The Yutaki range has the maximum A+++ energy classification in all its ranges ensuring you make savings on your energy bills, reduce electricity consumption and the impact on the environment.

3 Hitachi now offers the widest range of R32 air source heat pumps on the market. The new 4.3 kW R32 monobloc is ideal for new builds

	Min - Max
RAS-2WHVNP	1.85 - 7.0
RAS-2.5WHVNP	1.95 - 9.0
RAS-3WHVNP	2.1 - 11.0
RAS-4WH(V)NPE	4.3 - 15.2
RAS-5WH(V)NPE	4.8 - 16.7
RAS-6WH(V)NPE	5.5 - 17.8
RAS-8WHNPE	9.0 - 25.5
RAS-10WHNPE	10.0 - 32.0

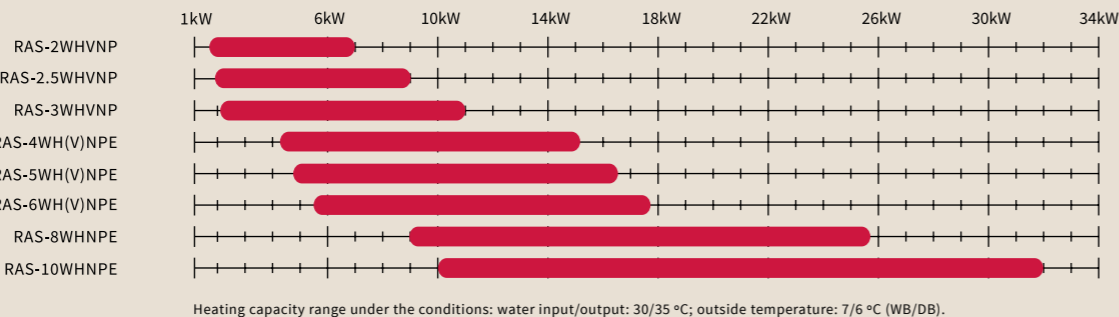

	Nom-Max
RAS-2WHVNP	3.8 - 4.9
RAS-2.5WHVNP	5.0 - 5.8
RAS-3WHVNP	6.0 - 7.0
RAS-4WH(V)NPE	7.2 - 11.8
RAS-5WH(V)NPE	9.5 - 12.6
RAS-6WH(V)NPE	10.5 - 13.7
RAS-8WHNPE	14.0 - 16.4
RAS-10WHNPE	17.5 - 20.6

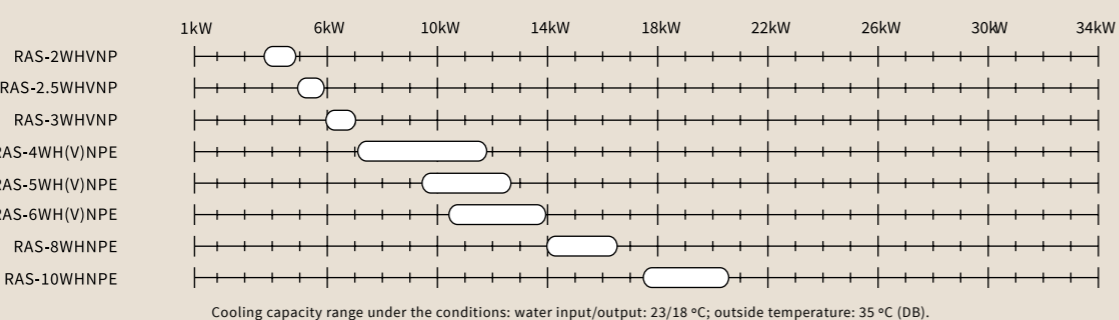

4 Hitachi high-efficiency Scroll Compressor



The Hitachi DC Inverter Scroll compressor has been designed to increase seasonal performance and reliability while reducing energy consumption.

The compressor is particularly efficient in intermediate seasons, offering high performance at low partial charges.

5 Proven quality



SG Ready

Hitachi heat pumps can be integrated into the smart energy grids of the future to help provide the low cost heating systems required to meet carbon reduction targets.



Proven quality

All heat pumps and water heaters in the European market are continuously tested by various certification schemes. These are usually the basis for qualifying for state subsidies. Hitachi heat pumps meet the high standards of the following quality accreditation schemes: Eurovent, MCS, Keymark, NF PAC, KIWA, EHPA.



Benefits

Yutaki air to water heat pumps

6 Savings from the very first bill

	Conventional gas boiler	Condensation gas boiler	Diesel boiler	Electricity (radiators)	Heat pump (Yutaki S 6 HP)
Performance (%)	92%	109%	89%	100%	457%
Energy consumption (kWh/year)	21,042.39	17,760.55	21,751.69	19,359.00	4,236.11
Energy cost (£/kWh)	0.0542	0.0542	0.08	0.15	0.15
Energy cost (£/year)	1,140.50	962.62	1,740.13	2,903.85	635.42
Gas emissions (kg CO2/kWh)	0.252	0.252	0.311	0.331	0.357
Gas emissions (tonne CO2/year)	5.30	4.48	6.76	6.40	1.51
Easy installation	Medium	Medium	High	Low	Medium
Maintenance	Medium	Medium	High	Low	Low
Additional energy costs compared to the heat pump installation	505.08	327.21	1,104.72	2,268.43	—

Estimate based on a 150 m² single-family property:
 Energy demand for heating + hot water (kWh/m²): 129.06.
 Energy demand for heating + hot water (kWh/year): 19,359.

Information sources:
 - CO₂ emission values taken from the report prepared by the Ministry of Energy, Tourism and Digital Agenda.
 - Energy prices taken from the Energy Prices Report: Fuels. Data correct at 20th December 2016.



7 Hitachi Experience

Hitachi has more than 60 years' experience in manufacturing heating equipment, with over 4.5 million ASHP systems produced and in excess of 400,000 customers throughout Europe. Our European factory produces the entire Yutaki ASHP range, designing it to meet the needs of the local European market. Its nearby location means we can control the whole design and manufacture process, thus guaranteeing the highest levels of quality, reliability and durability in all our equipment.

8 Optimised performance with the highest efficiency

The Yutaki range can provide heat with outside temperatures down to -25, uniquely to the market. It can also produce hot water up to 60c without the need for a backup heater.
 Yutaki systems are designed to work without backup electrical heaters but some have them factory fitted and for others they are an optional extra. Even when fitted the user can use the simple control systems to disable them.

9 Simple installation with easy maintenance

Unlike other models on the market, all Yutaki systems are designed for easy access to the components, thus allowing straightforward maintenance and ensuring cost savings.

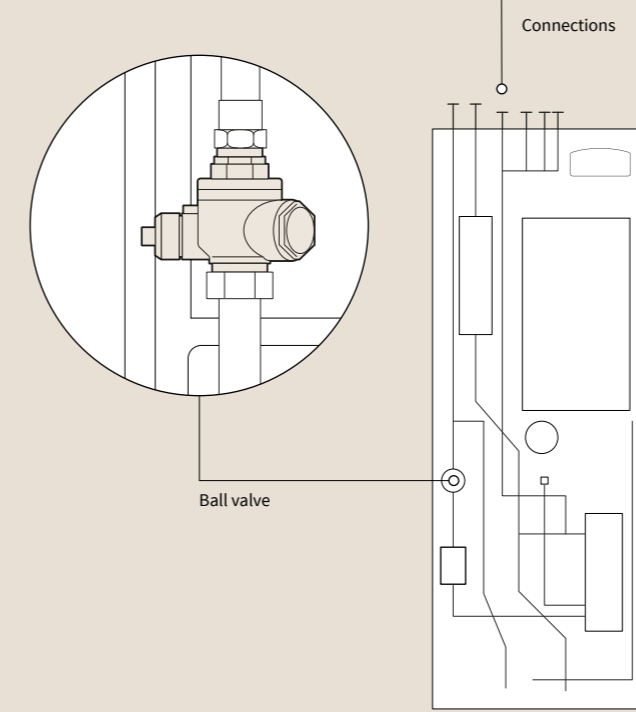
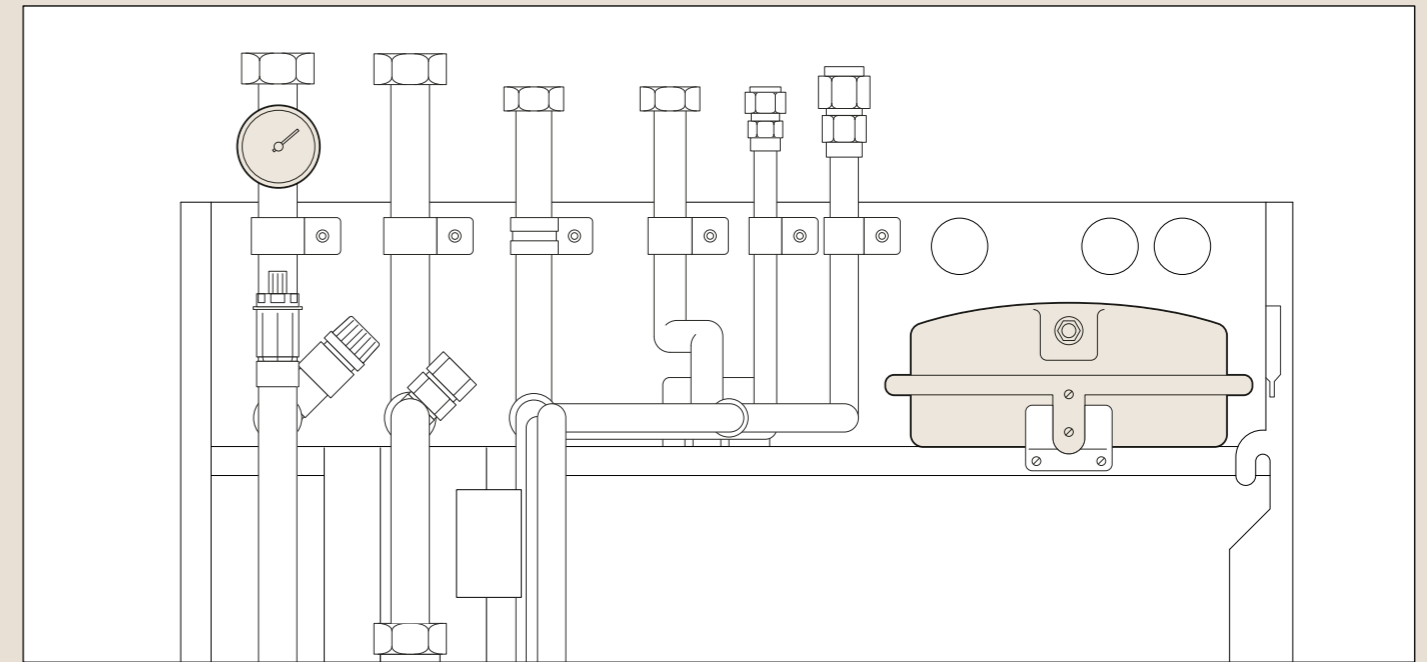

- Filter Plus shut-off valve: Yutaki units are fitted with a ball valve containing an interchangeable cylindrical filter that is easy to inspect and remove for maintenance work. The individual valve has two important functions: to perfectly seal the ball valves and to carefully filter the fluid, with its high-reliability protecting all the components in Hitachi's Yutaki systems.
- Compared to traditional use of three components (one filter and two shut-off valves), the Filter Plus guarantees lower charge losses, in addition to the obvious benefits in terms of cost, installation and space.
- Accessibility: easy access to all components from the front of the machine.
- Pipes: the pipes are perfectly aligned at the back of the unit, making installation much easier compared to other manufacturers.

10 Yutaki, configured in under 5 minutes

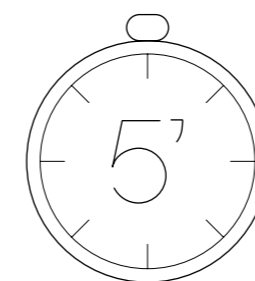

Quick, easy configuration thanks to its intuitive new wizard set-up interface.
 Having the same control throughout the range means any Yutaki can be configured in just 5 minutes.

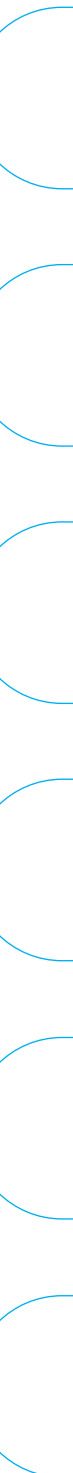

Benefits

Yutaki air to water heat pumps

11 Easy, smart control



Hitachi has the same controller and functions for all ranges. Designed to be user-friendly, handling all system functions: heating, cooling, hot water and swimming pool settings.

The control, with an LCD display and thermostat, centralises all applications without the need for external elements. It can be used for straightforward control of operations such as daily and weekly programming, managing water production temperature, operating modes, etc. It can also be used as a zone thermostat, and even combined with Hitachi's wireless thermostat.

12 Yutaki adapts to the needs of modern properties

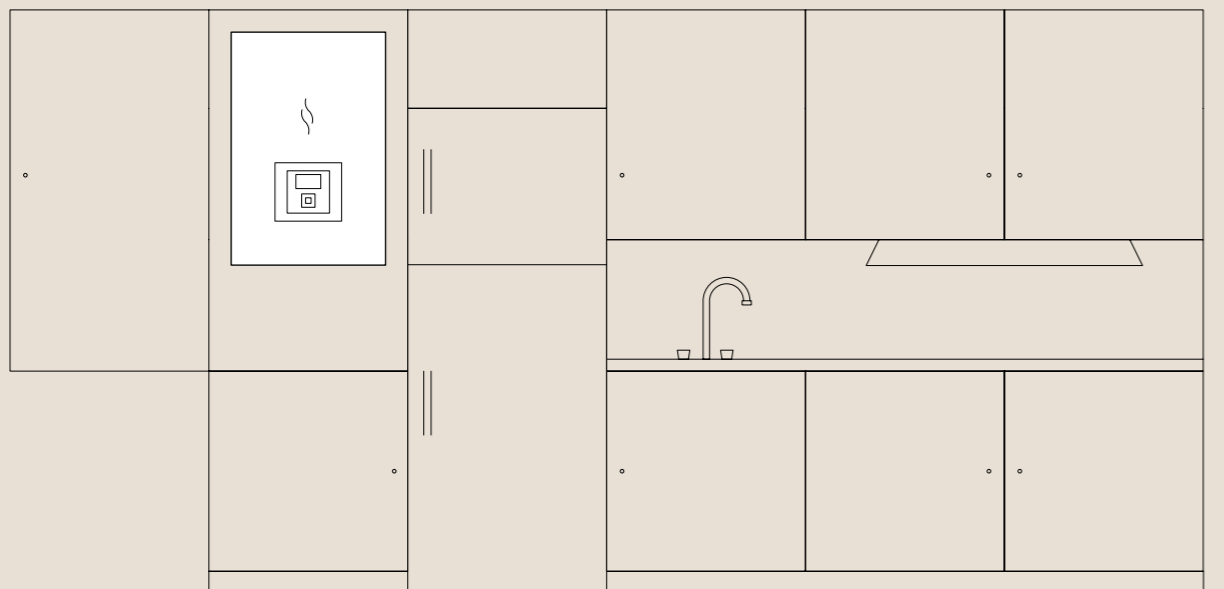

All Yutaki models have been designed to ensure space is not a problem. Their compact size means they can be hidden away in confined spaces, even inside a kitchen cabinet.

Yutaki models are compact and lightweight, designed for smaller surfaces, without sacrificing power and efficiency.

13 No matter where you are



Turn the system on and off and regulate the temperature, or turn on pool heating from anywhere thanks to Yutaki's Hi-Box pack and the free Hi-Kumo app.

14 Smart defrost cycle

Optimised refrigerant cycle thanks to smart defrost control and a hot gas bypass to the outdoor unit's heat exchanger, making defrosting virtually unnoticeable.

This exclusive improvement reduces time between defrosts, improves energy efficiency, and guarantees machine power at low temperatures, avoiding the need for the backup heating element.

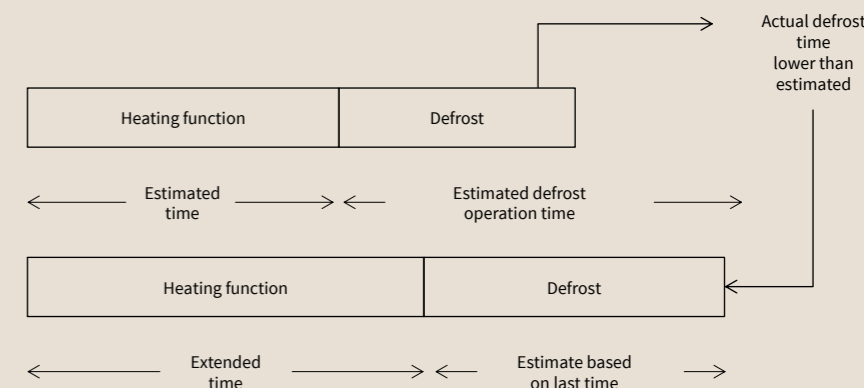

15 Additional benefits

Having an expansion valve in the indoor unit allows longer pipe installations while minimising energy losses in the cooling section.

Thanks to the longer pipe length, the Yutaki range can supply greater cooling power to the installation in the summer cycle without affecting the system's electrical consumption.

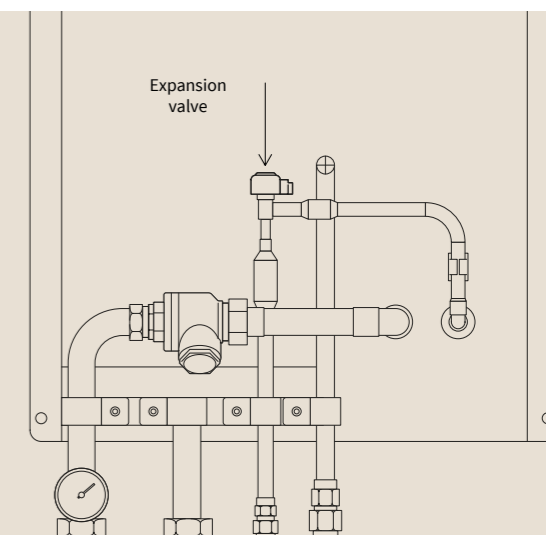

Yutaki air to water heat pumps

Hi-Toolkit for Home

Yutaki ASHP energy simulation and sizing software

This functional software can be used to quickly and easily select all the systems in Hitachi's Yutaki Air source heat pump range, generating a detailed report with information about the selected machine.

It has a complete database of the main cities in the UK & Ireland and their annual temperatures, in order to carry out an annual energy simulation for the 8,760 hours of the year. Once the simulation is complete, the software compares energy consumption and CO2 emissions with other conventional heating systems in order to evaluate the energy savings that can be achieved when installing Yutaki Air source heat pump equipment.

The website can be found at: www.hitachi-hitoolkit.com/heating

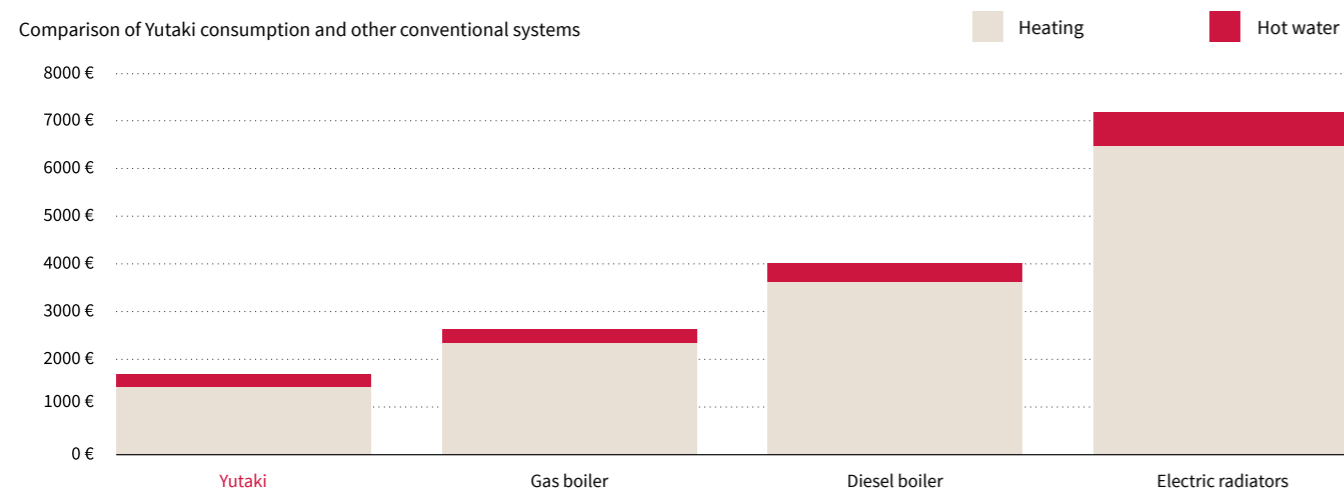
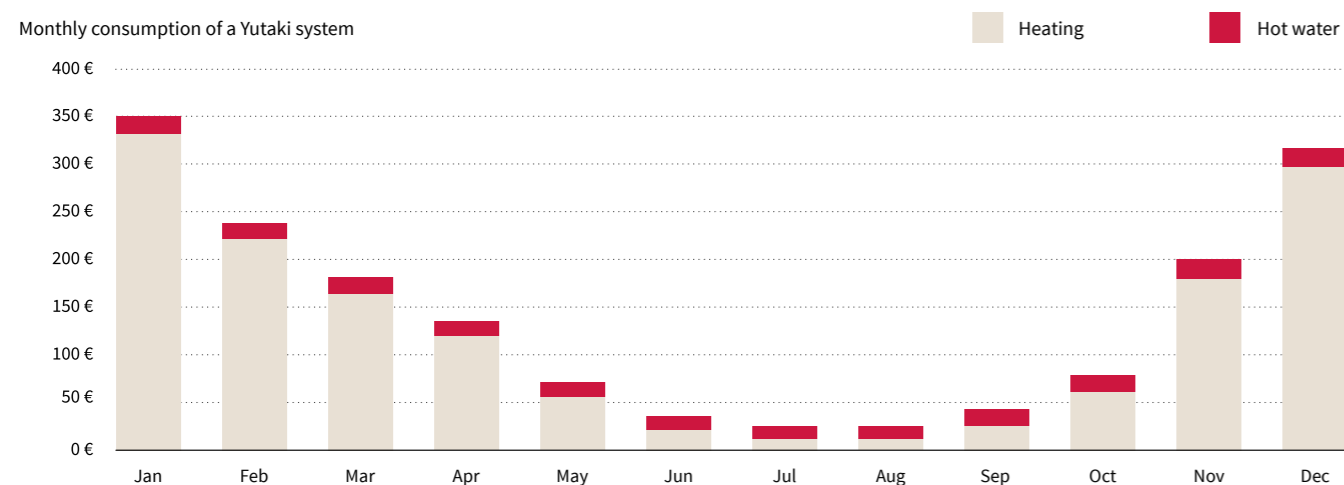

Hitachi has a free online tool for simplified hydraulic configurations of its whole Yutaki ASHP range.

The main elements of the installation can be configured in a few simple steps by simply answering a series of basic questions.

This also makes it easier to install the system, as it indicates directly where each sensor, pump and all other elements on the machine's connections board go.

The website can be found at: www.yutaki-applications.com/en

Hydraulic diagrams
Contact your usual Hitachi direct sales contact or distributor for more detailed hydraulic layouts or any special configurations your installation requires.

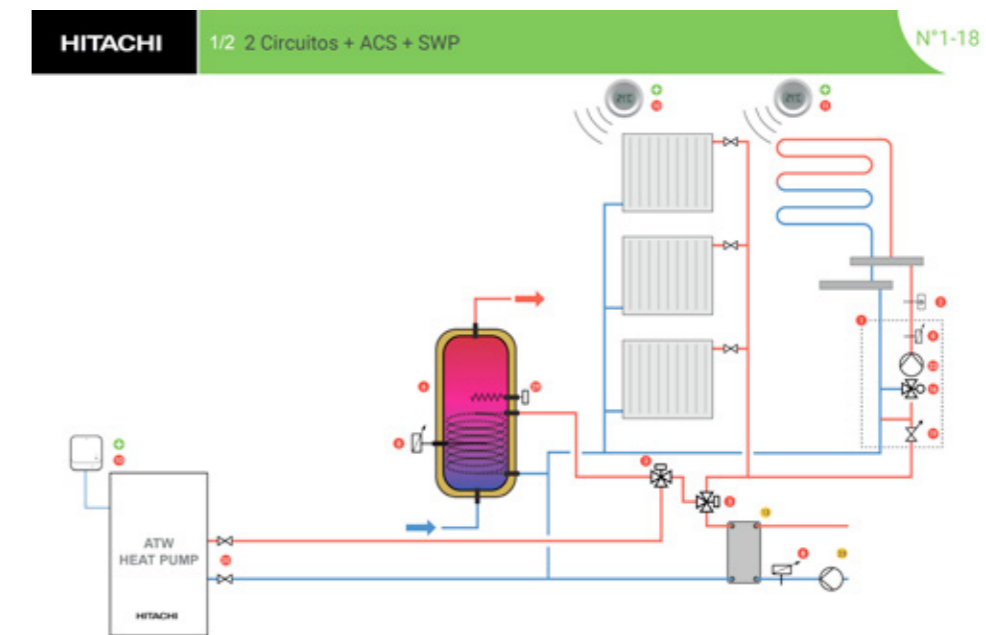

Multiple installation options

Yutaki air to water heat pumps

All your projects have different requirements and so you need flexible solutions. The Yutaki range is adaptable to the needs of each project from the simplest heating only set up to more complex configurations.

Below are some simplified configurations, as examples of the most common installations. Please contact our Technical Service team department if you would like further details about them or their components, or information about more complex configurations.

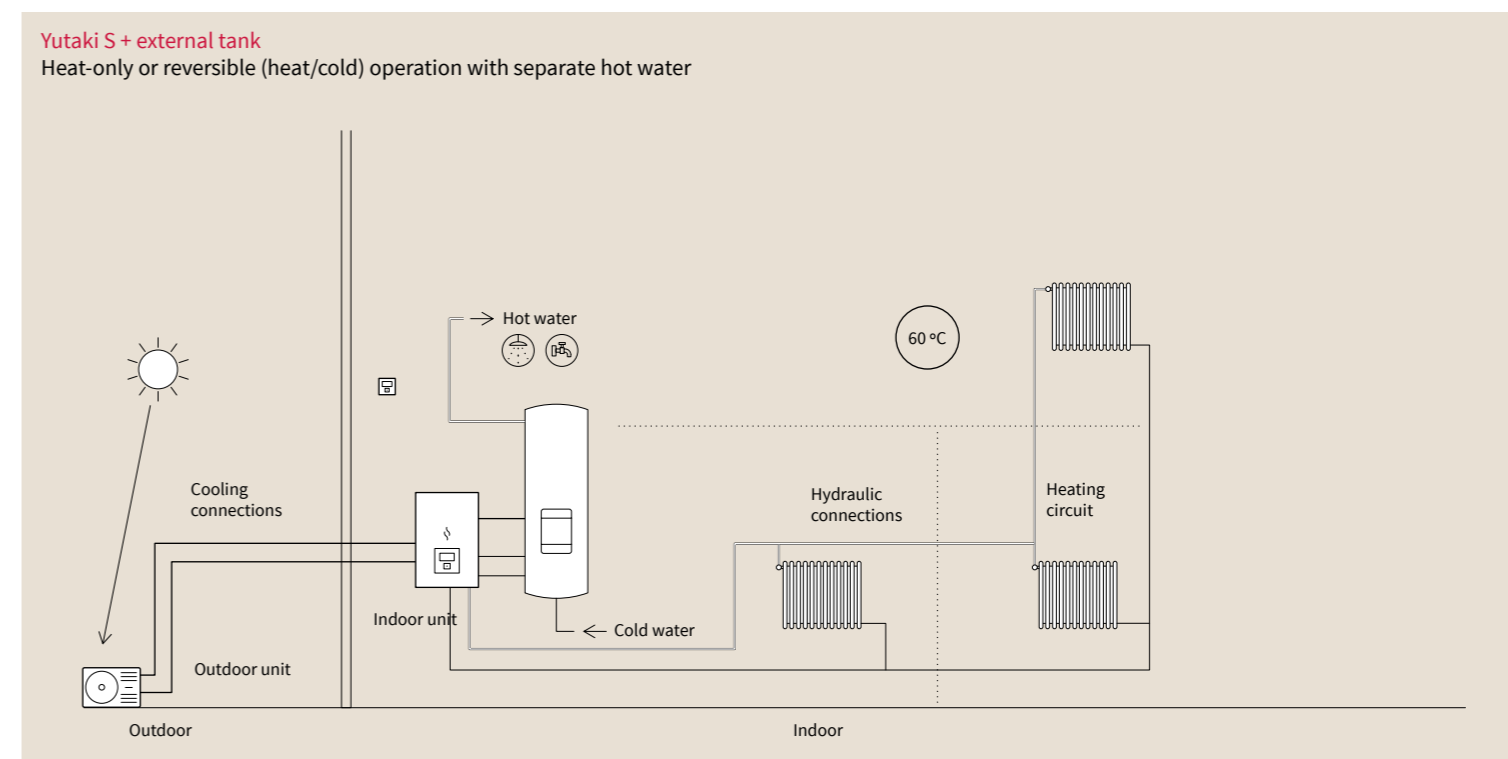
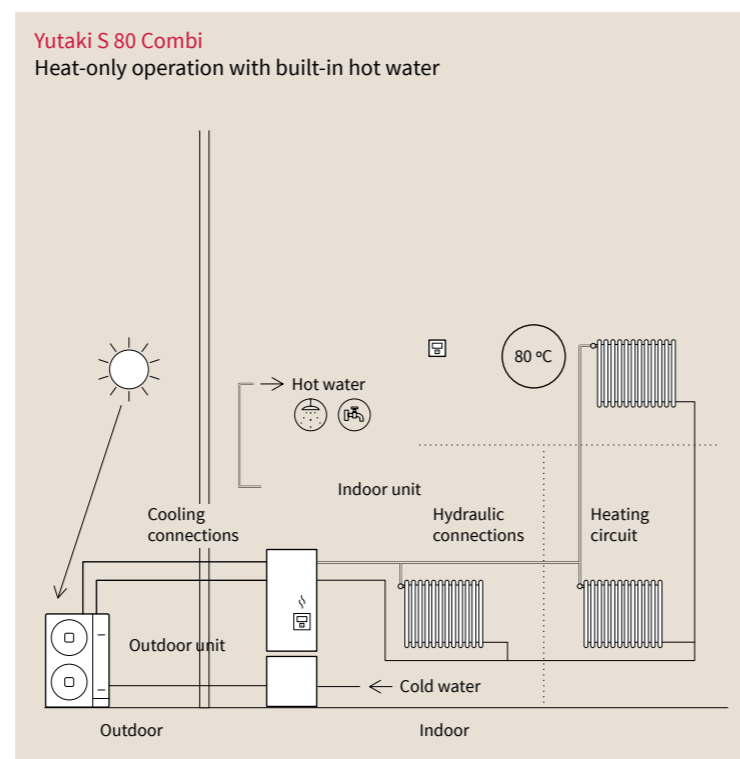
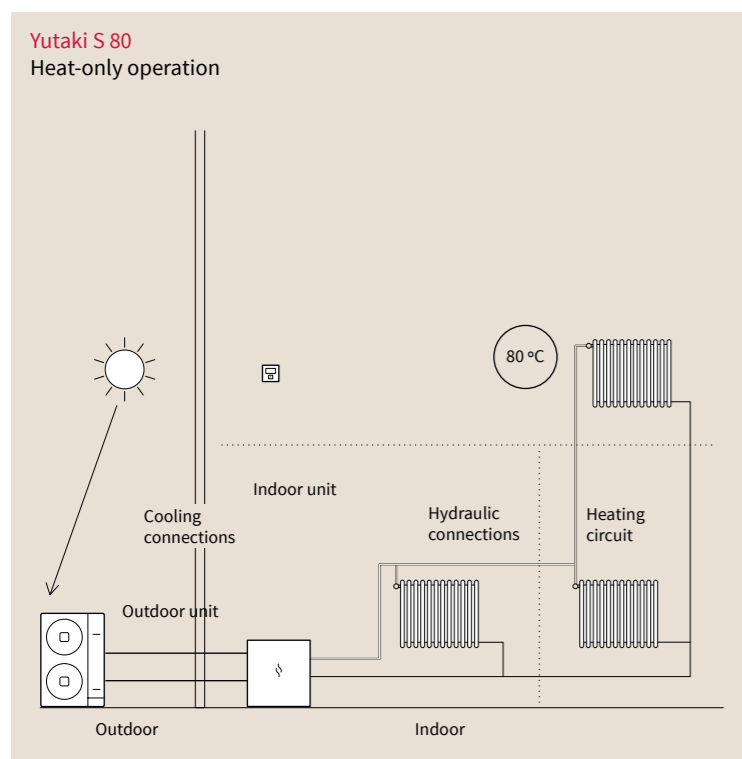
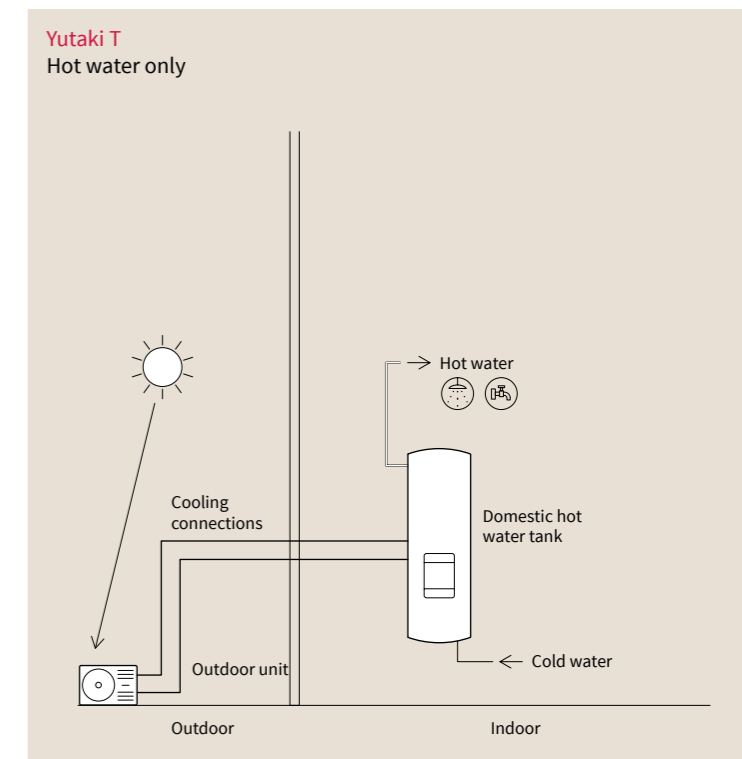
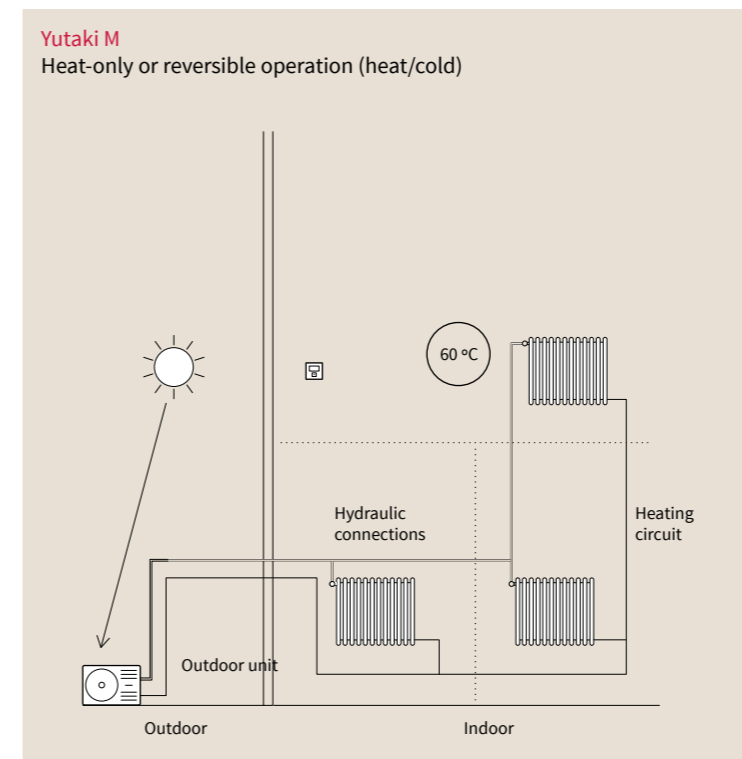
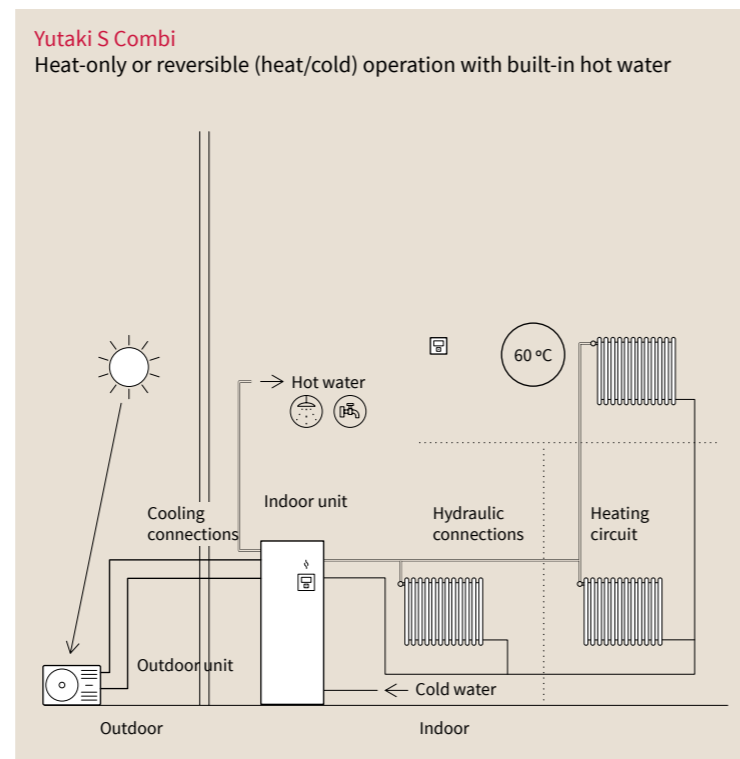
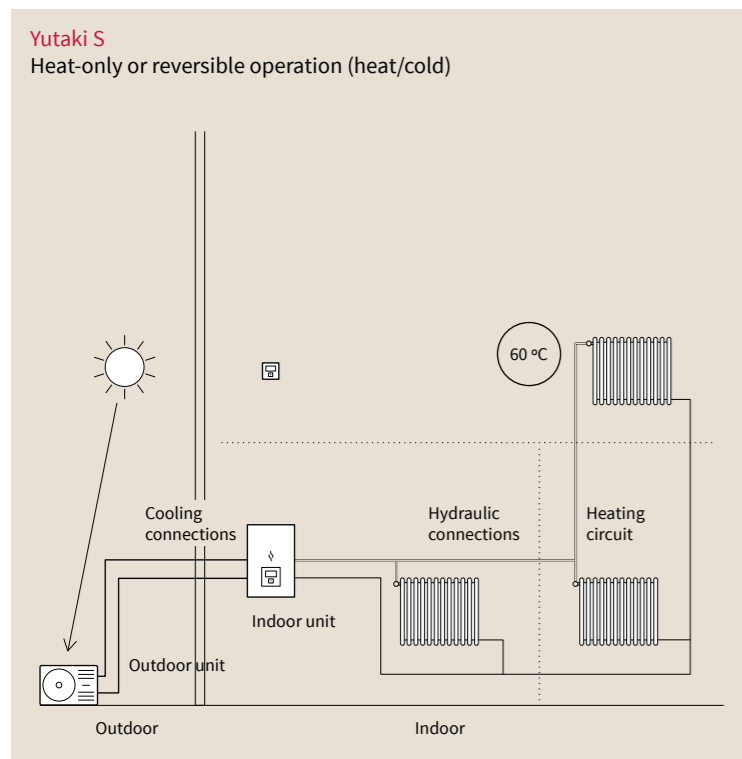

Multiple installation options

Air source heat pumps with cascade control

To cover the larger installations where a high thermal load is required an optional cascade controller can be installed (ATW-YCC-01). This intelligent controller manages up to

8 Yutaki ASHPs capable of producing 256 kW of renewable heat. Each unit works together as one to deliver the most efficient solution for your building whatever the requirements.

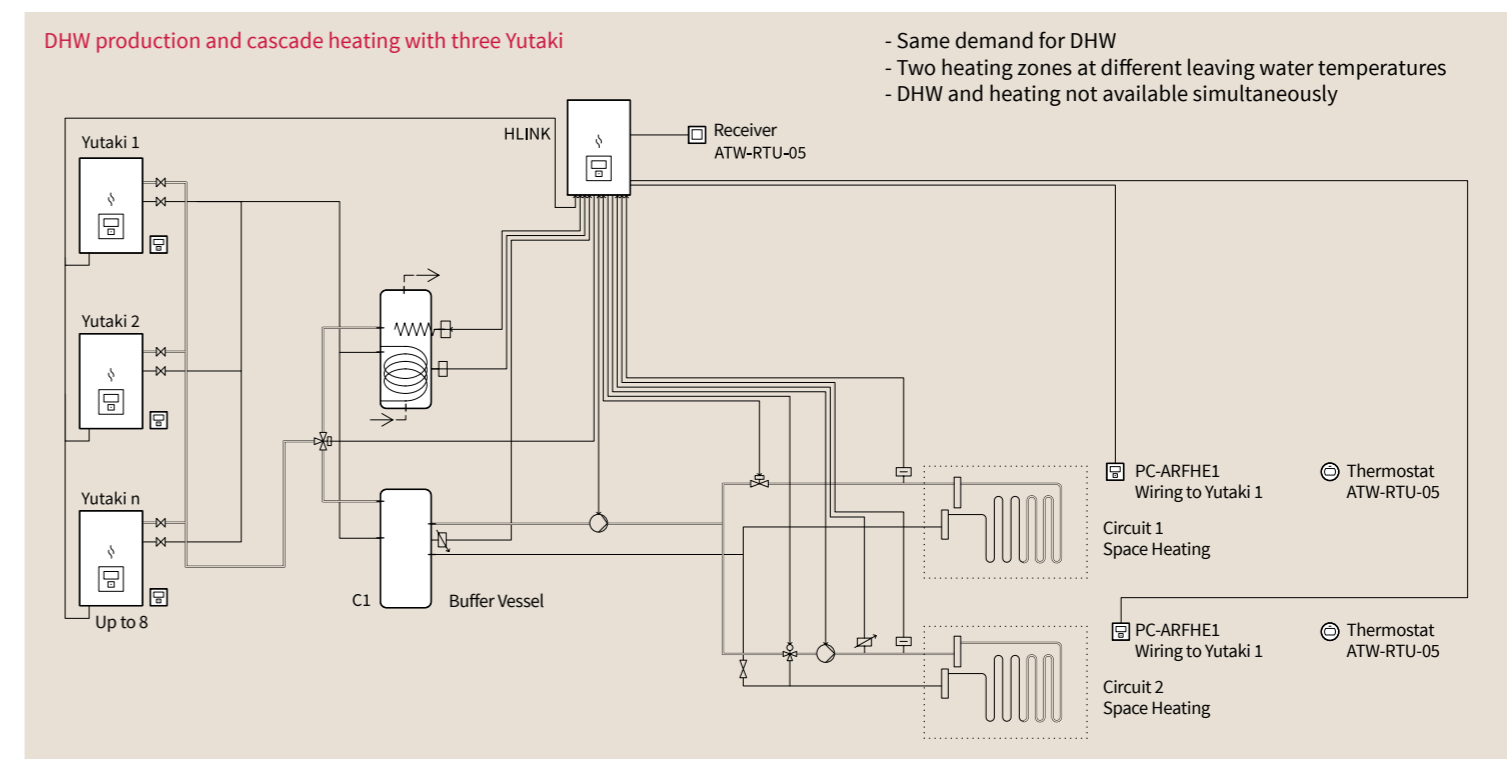
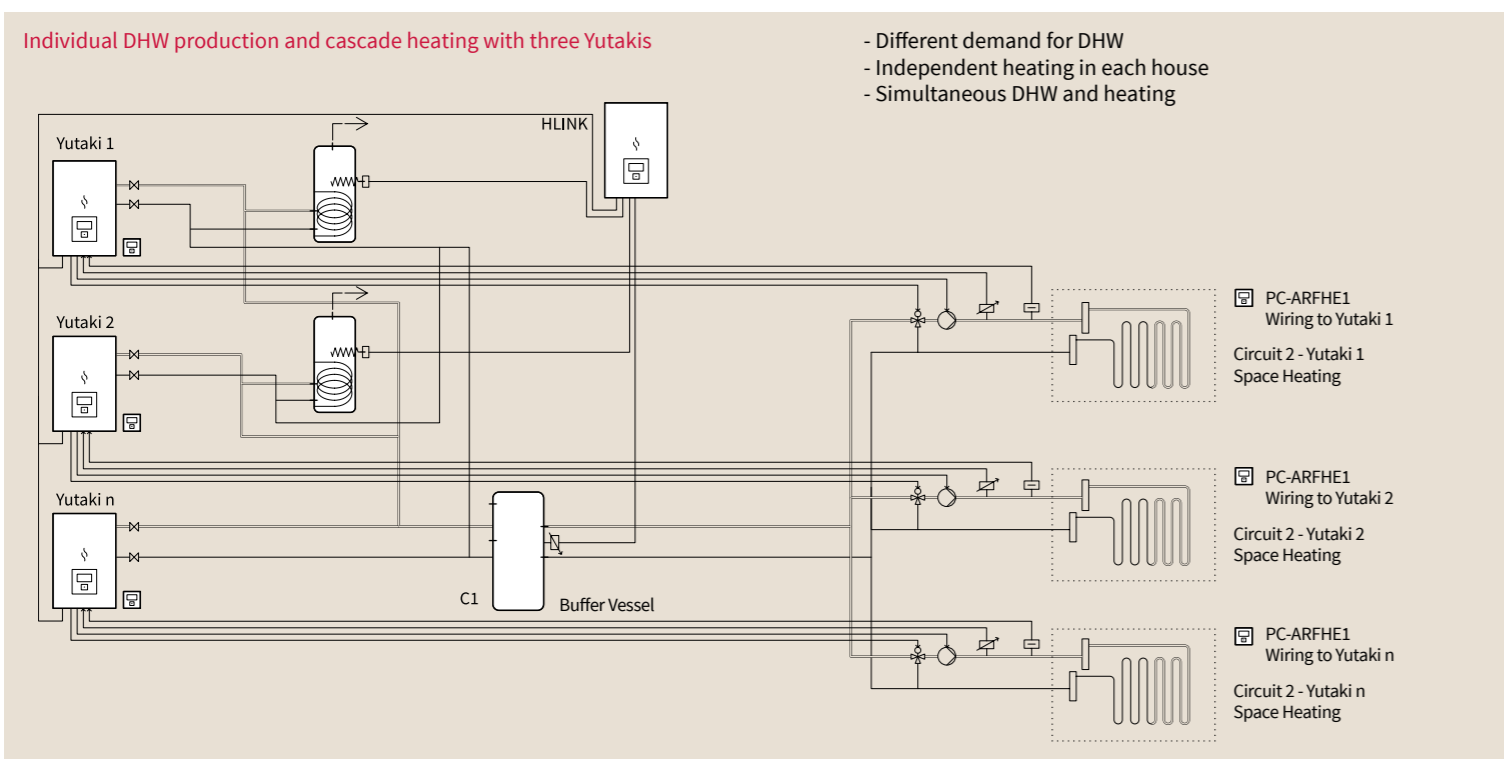
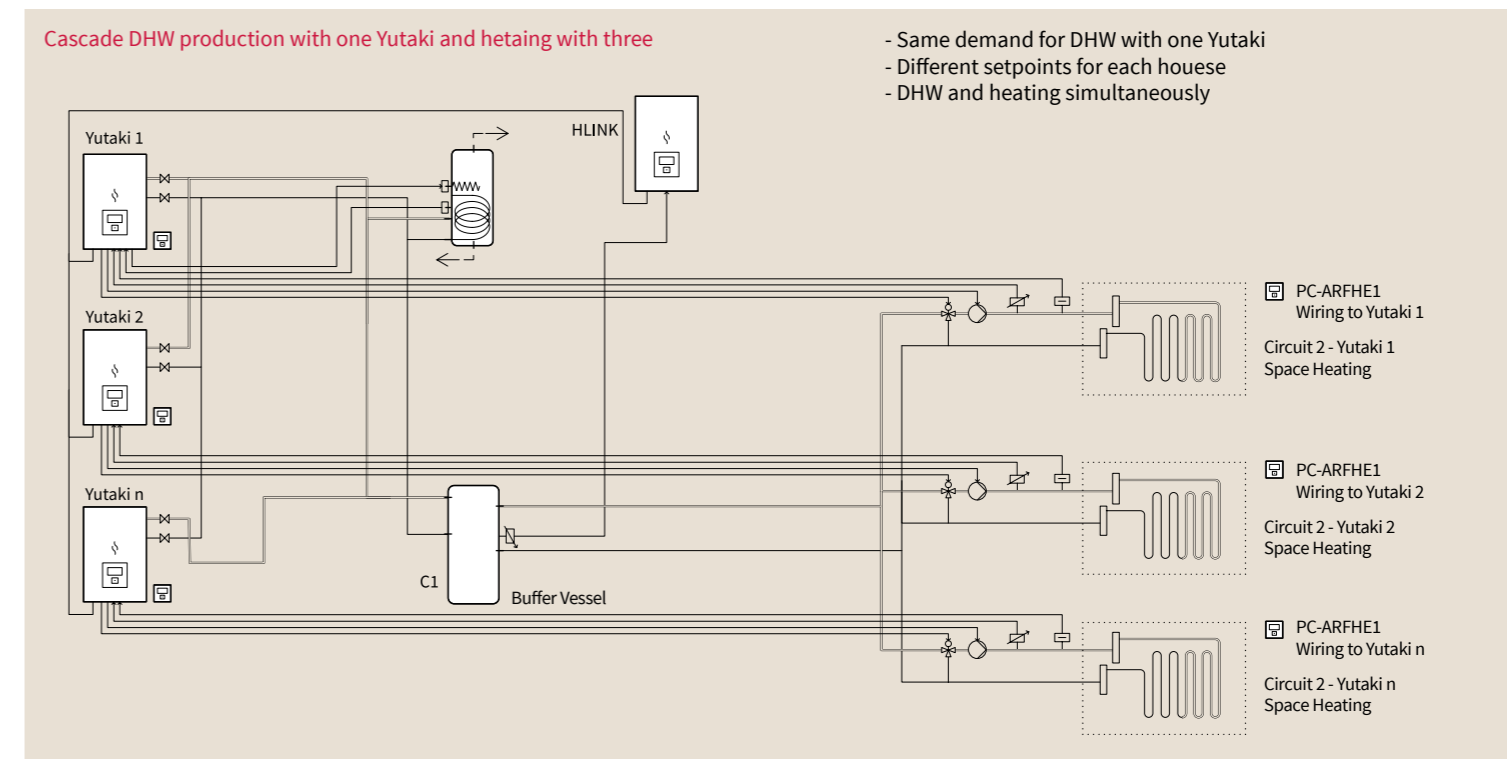
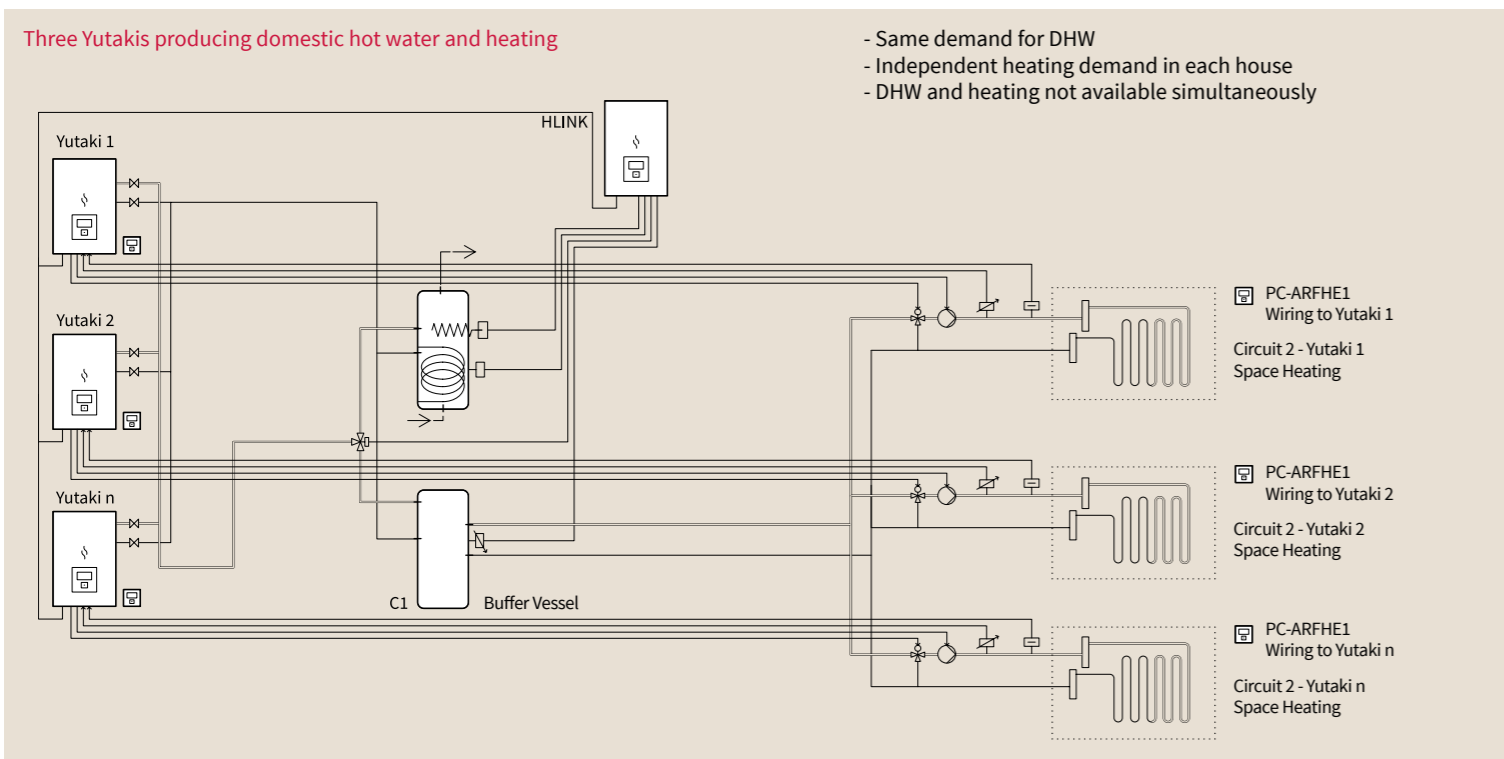

Yutaki S

Compact, highly efficient system: heating, hot water and cooling



Satisfies all demands

Extensive range of outputs from 1.85 kW to 32.00 kW for heating, and from 3.80 kW to 20.60 kW for cooling.
25.50 and 32.00 kW models are unique on the market.

Compact dimensions

Its compact size and easy installation make it the perfect system for confined spaces. Models from 4.30 to 7.50 kW, even fitting in a kitchen cabinet. (Fig. 1)

Fig. 1

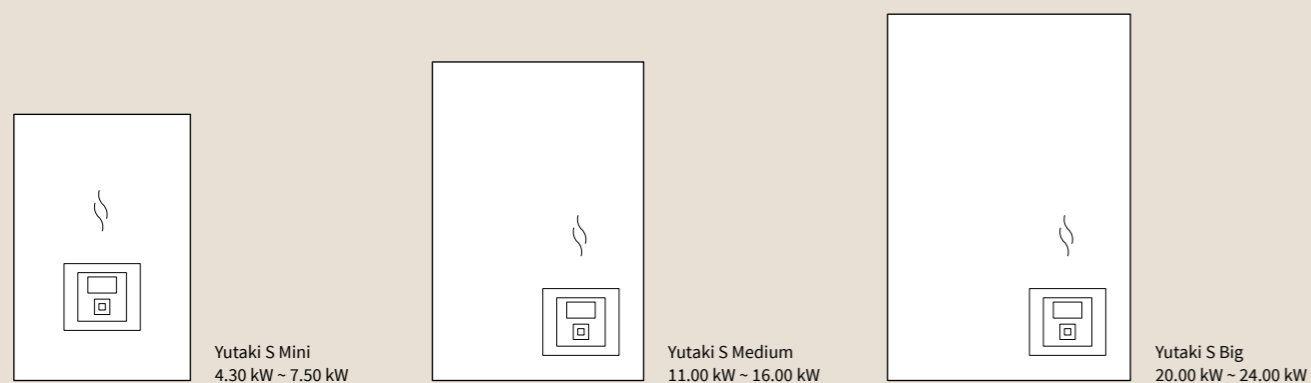

Best performance on the market*

The Yutaki S has the **highest COP** compared to competing systems, which translates into lower energy consumption and bigger savings. All units have up to A+++ maximum energy efficiency.
*Depends on model.

Exclusive design to work in the most extreme conditions

Its broad operating range means the system can work in extreme outdoor conditions: **from -25°C to +46°C**.

Reduced consumption

Unique on the market - water temperature up to 60 °C without the need for a backup heating element, achieving significant savings compared to other manufacturer models.

Indoor units

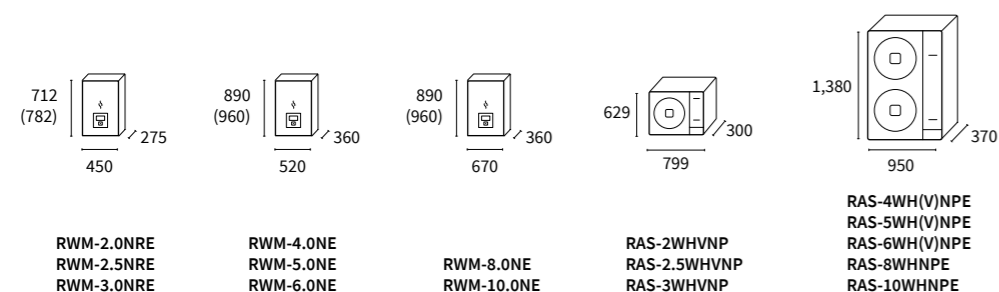

Outdoor units

Yutaki S

System		Yutaki S 2	Yutaki S 2.5	Yutaki S 3	Yutaki S 4	Yutaki S 5	Yutaki S 6	Yutaki S 8	Yutaki S 10
Capacity	Heating (Min/Nom/Max) kW	1.85/4.30/7.00	1.85/6.00/8.60	2.10/8.00/11.00	4.30/11.00/15.20	4.80/14.00/16.70	5.50/16.00/17.80	9.00/20.00/25.50	10.00/24.00/32.00
	Cooling (Nom/Max) kW	4.00/5.00	5.30/6.20	6.50/7.00	7.20/11.80	9.50/12.60	10.50/13.70	14.00/16.40	17.50/20.60
Consumption	Heating (Nom) kW	0.82	1.25	1.74	2.20	2.97	3.50	4.65	5.59
	Cooling (Nom) kW	1.00	1.47	1.94	2.18	2.68	3.17	4.48	6.22
Electrical power	1~230V 50Hz	-	-	-	-	-	-	-	-
	3N~400V 50 Hz	-	-	-	-	-	-	-	-
COP (Water 35°C, Ambient 7°C)	Nominal	5.25	4.80	4.60	5.00	4.71	4.57	4.30	4.29
EER (Water 7°C, Ambient 35°C)	Nominal	4.00	3.60	3.35	3.30	3.30	3.31	3.12	2.81
Energy rating at 35°C		A+++	A+++	A+++	A+++	A+++	A++	A++	A+
Seasonal efficiency at 35°C, SCOP / ηs		4.93/181	4.58/177	4.25/175	4.75/189	4.45/176	3.90/153	3.83/152	3.60/142
Energy rating at 55°C		A++	A++	A++	A++	A++	A++	A+	A+
Seasonal efficiency at 55°C, SCOP / ηs	Medium climate	3.58/133	3.38/130	3.25/125	3.50/137	3.43/134	3.23/126	3.13/122	2.98/118
ESEER		3.36	3.26	3.26	3.33	3.29	2.84	3.56	3.32
SEER / ηs	Single-phase	4.11/162	4.13/162	3.95/155	4.93/194	4.83/190	4.70/185	4.29/169	4.06/159
	Three-phase	-	-	-	5.05/199	4.92/194	4.78/188	-	-
Outdoor operating temperatures	Heating (DB) °C	-20 to 25	-20 to 25	-20 to 25	-25 to 25	-25 to 25	-25 to 25	-25 to 25	-25 to 25
	Hot water (DB) °C	-20 to 35	-20 to 35	-20 to 35	-25 to 35	-25 to 35	-25 to 35	-25 to 35	-25 to 35
	Cooling (DB) °C	10 to 46	10 to 46	10 to 46	10 to 46	10 to 46	10 to 46	10 to 46	10 to 46
Water production temperatures	Heating °C	20 to 55	20 to 55	20 to 55	20 to 60	20 to 60	20 to 60	20 to 60	20 to 60
	Hot water °C	30 to 75	30 to 75	30 to 75	30 to 75	30 to 75	30 to 75	30 to 75	30 to 75
	Cooling °C	5 to 22	5 to 22	5 to 22	5 to 22	5 to 22	5 to 22	5 to 22	5 to 22
Refrigerant pipe diameter	Liquid-gas inches	1/4-1/2	1/4-1/2	1/4-5/8	3/8-5/8	3/8-5/8	3/8-5/8	3/8-1	1/2-1
Water pipe diameter	Input-output inches	1-1	1-1	1-1	1-1/4 - 1-1/4	1-1/4 - 1-1/4	1-1/4 - 1-1/4	1-1/4 - 1-1/4	1-1/4 - 1-1/4
Indoor unit		RWM-2.ONRE	RWM-2.5NRE	RWM-3.ONRE	RWM-4.ONE	RWM-5.ONE	RWM-6.ONE	RWM-8.ONE	RWM-10.ONE
Minimum water volume of the installation	l	28	28	28	38	46	55	76	79
Water flow	(Min-Nom-Max) m ³ /h	0.50 - 0.77 - 1.90	0.60 - 1.03 - 2.00	0.60 - 1.29 - 2.10	1.00 - 1.89 - 2.90	1.10 - 2.41 - 3.00	1.2 - 2.75 - 3.00	2.00 - 3.44 - 4.50	2.20 - 4.13 - 4.60
Emergency heating element in primary	Steps/Capacity n°/kW	3 / 1 - 1 - 1	3 / 1 - 1 - 1	3 / 1 - 1 - 1	3 / 2 - 2 - 2	3 / 2 - 2 - 2	3 / 2 - 2 - 2	3 / 3 - 3 - 3	3 / 3 - 3 - 3
Sound power	dB(A)	37	37	37	39	39	39	47	47
Dimensions (H (with connections) x W x D)	mm	712(782) x450x275	712(782) x450x275	712(782) x450x275	890(960) x520x360	890(960) x520x360	890(960) x520x360	890(960) x670x360	890(960) x670x360
Weight	kg	35	36	37	46	48	48	60	62
Maximum current	Single-phase A	28.9	28.9	28.9	43.4	43.4	43.4	-	-
	Three-phase A	-	-	-	24.2	24.2	24.2	29.2	29.2
Outdoor unit		RAS-2.WHVNP	RAS-2.5WHVNP	RAS-3.WHVNP	RAS-4.WH(V)NPE	RAS-5.WH(V)NPE	RAS-6.WH(V)NPE	RAS-8.WHNPE	RAS-10.WHNPE
Air flow	m ³ /h	2,526	2,526	2,982	4,800	5,400	6,000	7,620	8,040
Sound pressure	dB(A)	46	47	50	49	50	50	59	60
Sound power	dB(A)	61	63	64	64	65	67	73	74
Minimum pipe length	m	3	3	3	5	5	5	5	5
Maximum pipe length	m	50	50	50	75	75	75	70	70
Maximum height difference (highest OU/lowest OU)	m	30/20	30/20	30/20	30/20	30/20	30/20	30/20	30/20
Compressor		Scroll DC Inverter R32	Scroll DC Inverter R32	Rotary DC Inverter R32	Scroll DC Inverter R410A	Scroll DC Inverter R410A	Scroll DC Inverter R410A	Scroll DC Inverter R410A	Scroll DC Inverter R410A
Refrigerant		R32	R32	R32	R410A	R410A	R410A	R410A	R410A
Refrigerant charge (length without additional charge)	kg (m)	1.2 (10)	1.3 (10)	1.3 (10)	3.3 (15)	3.4 (15)	3.4 (15)	5.0 (15)	5.3 (15)
Additional refrigerant charge	g/m	15	15	15	60	60	60	65	65
Dimensions (H x W x D)	mm	629x799x300	629x799x300	629x799x300	1,380x950x370	1,380x950x370	1,380x950x370	1,380x950x370	1,380x950x370
Weight	kg	45	45	44	103	103	103	137	139
Maximum current	Single-phase	13	13	17	30	30	30	-	-
	Three-phase	-	-	-	14	14	16	24	24

Compatible controls and accessories:

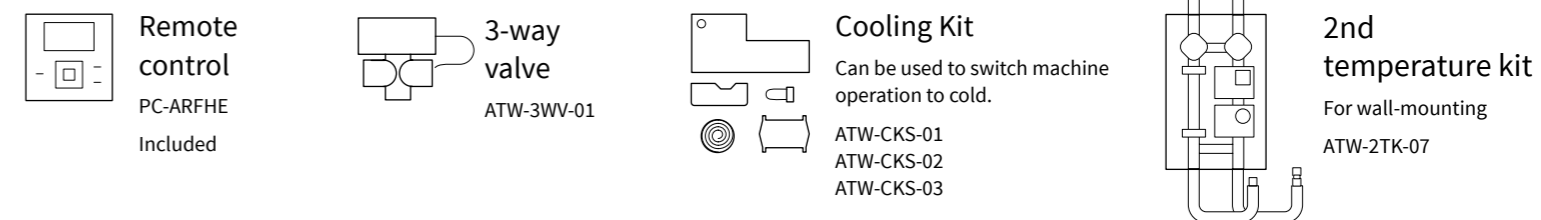

Internal design

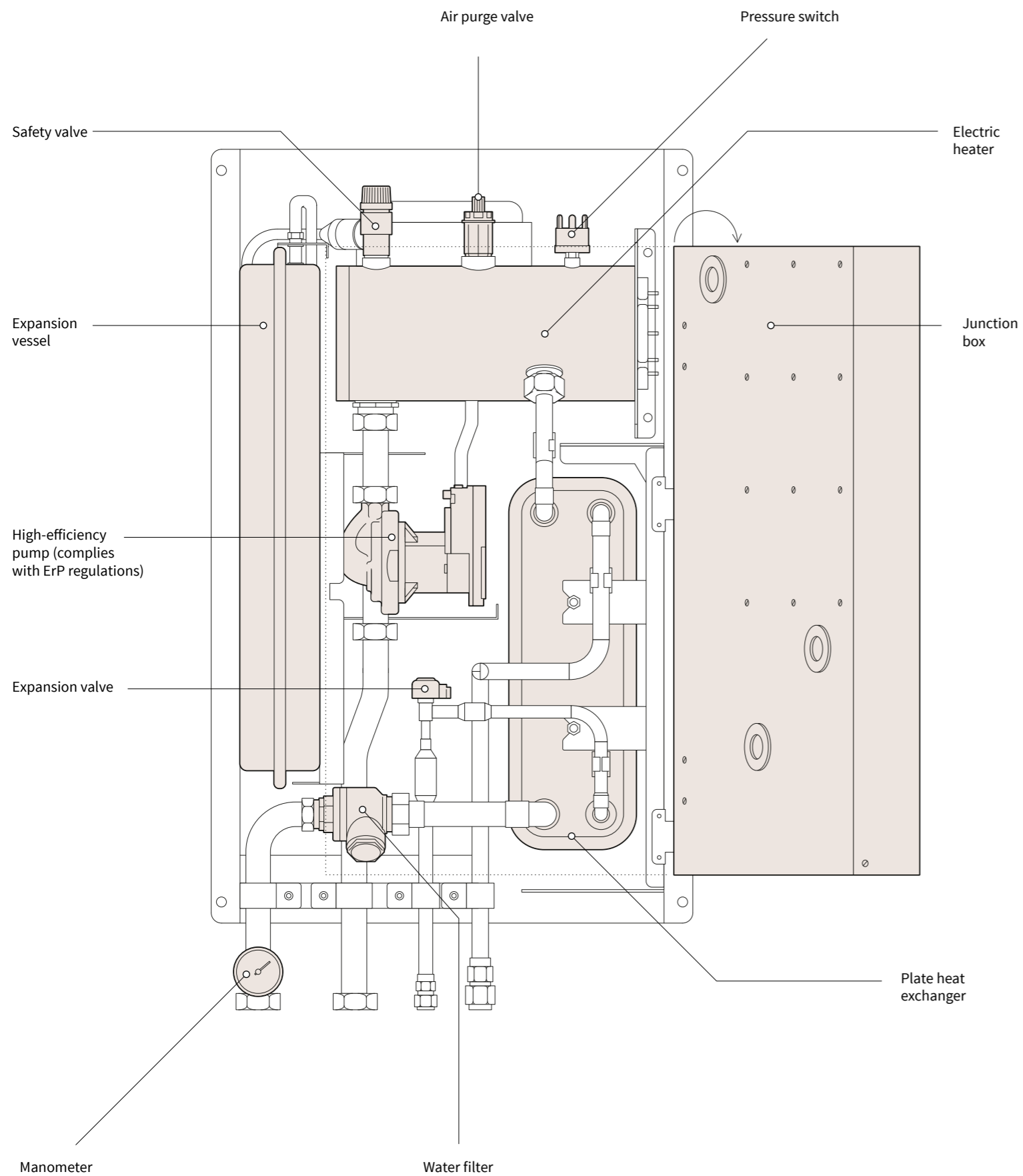

Configurations

Radiator and underfloor heating at the same temperature; one zone + hot water by external tank.

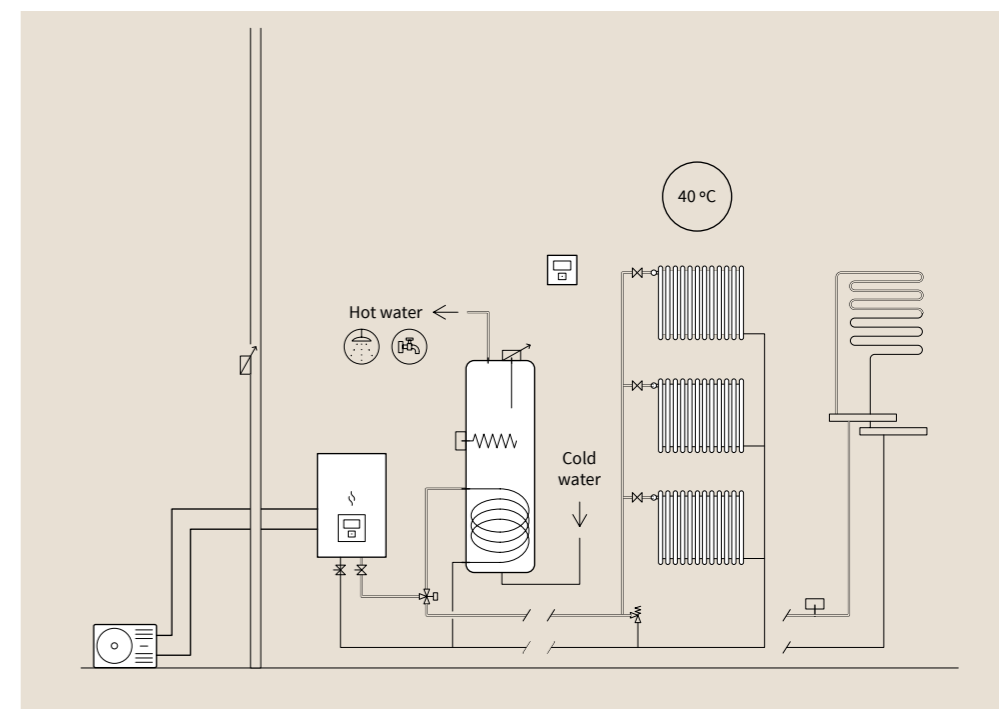

Radiator and underfloor heating at different temperatures; two zones + hot water by external tank.

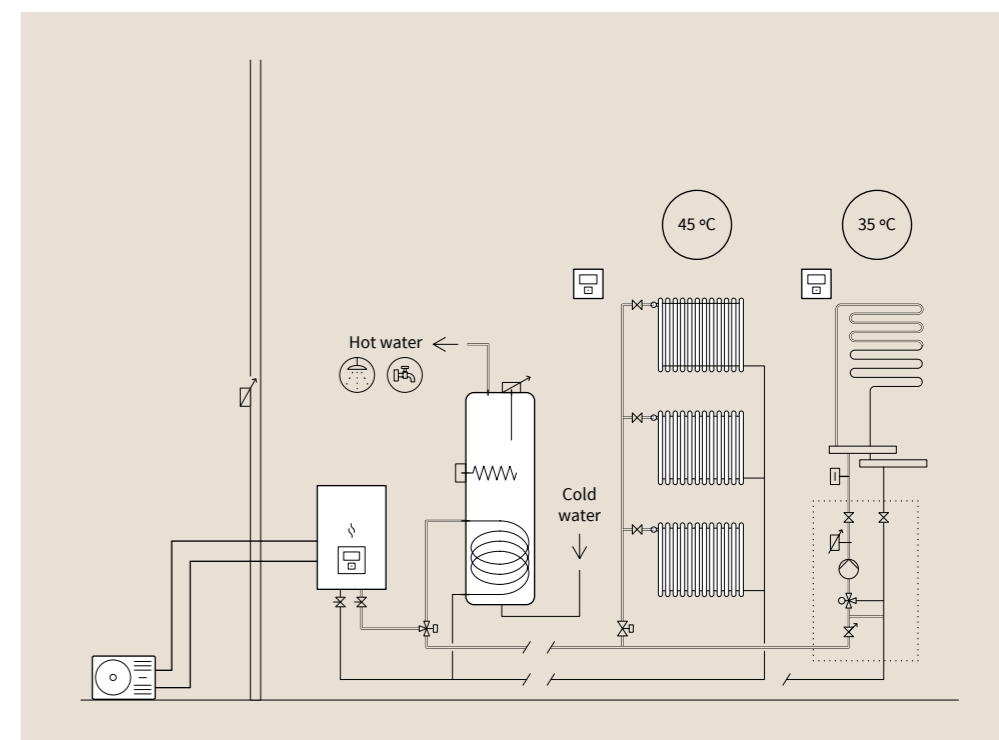

Cascade operation. Heating or cooling.

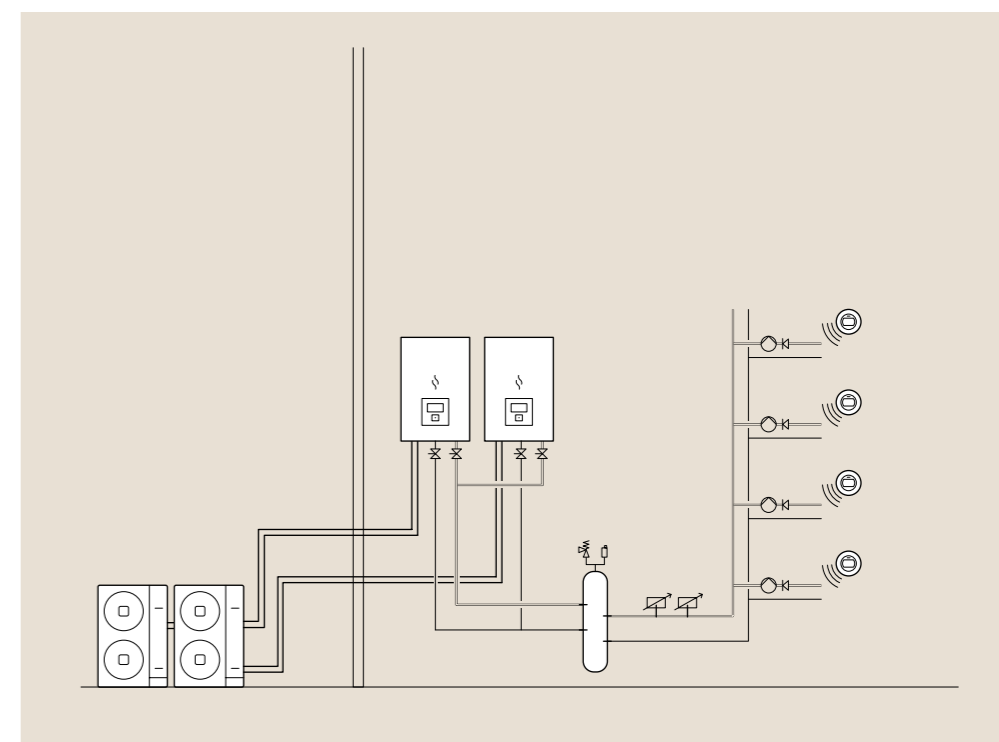

Yutaki S Combi

Compact all-in-one system: heating, hot water and cooling with integrated stainless steel tank



Extensive range of models

The Yutaki S Combi is designed for any type of installation thanks to its wide range of models. From 1.85 kW to 17.80 kW for heating, and from 3.80 kW to 13.70 kW for cooling.

Space-saving and ultraquiet

The Yutaki S Combi unit can be installed in the kitchen thanks to its compact size and low noise level.

The large space saving of up to 70 % compared to other system is due to the innovative hot water tank integrated into the indoor unit.

Choose your size

The Yutaki S Combi includes 2 tank models: 200 and 260 L

Moreover, the 2nd temperature kit can be incorporated into the 200 L unit.

Easy installation and maintenance

Compared to a split system (indoor unit-hot water tank), the Yutaki S Combi allows fast installation with minimal costs since:

- All water and refrigerant connections are aligned at the top. (Fig. 1)
- Most components are accessible from the front of the unit.
- Easy access to information from the LCD control without having to open the indoor unit.

Stainless steel tank with built-in heating element

The only compact model fitted with a hot water tank with backup heating element for emergency hot water, activated with a single button.

Fig. 1

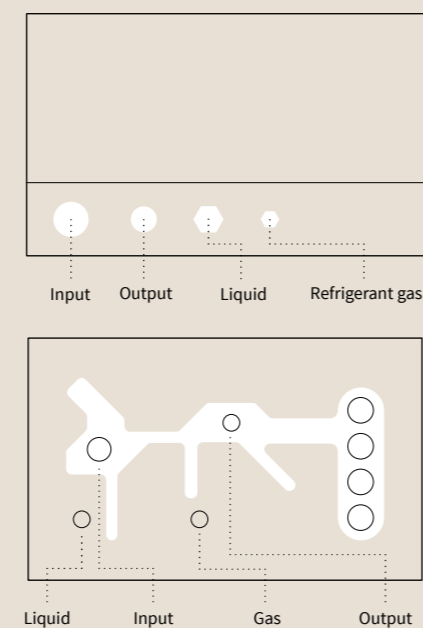

Indoor units

Outdoor units

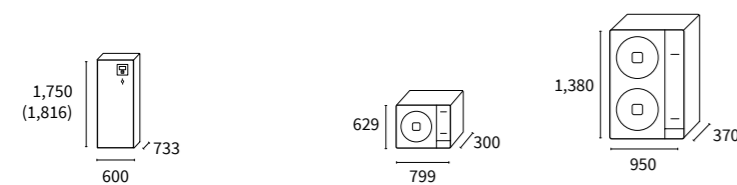

RWD-2.0NRW(S)E RWD-4.0NW(S)E
RWD-2.5NRW(S)E RWD-5.0NW(S)E
RWD-3.0NRW(S)E RWD-6.0NW(S)E

RAS-2WHVNRP RAS-2.5WHVNRP
RAS-3WHVNRP

RAS-4WH(V)NPE RAS-5WH(V)NPE
RAS-6WH(V)NPE

Yutaki S Combi

System		Yutaki S 2 Combi	Yutaki S 2.5 Combi	Yutaki S 3 Combi	Yutaki S 4 Combi	Yutaki S 5 Combi	Yutaki S 6 Combi	
Capacity	Heating (Min/Nom/Max) kW	1.85/4.30/6.50	1.85/6.00/8.60	2.10/8.00/11.00	4.30/11.00/15.20	4.80/14.00/16.70	5.50/16.00/17.80	
	Cooling (Nom/Max) kW	4.00/5.00	5.30/6.00	6.50/7.00	7.20/11.80	9.50/12.60	10.50/13.70	
Consumption	Heating (Nom) kW	0.82	1.25	1.65	2.20	2.97	3.50	
	Cooling (Nom) kW	1.00	1.47	1.94	2.18	2.68	3.17	
Electrical power	1 ~230V 50Hz	-	-	1 ~230V 50Hz	1 ~230V 50Hz	1 ~230V 50Hz	1 ~230V 50Hz	
	3N ~400V 50 Hz	-	-	-	3N ~400V 50 Hz	3N ~400V 50 Hz	3N ~400V 50 Hz	
COP (Water 35°C, Ambient 7°C)	Nominal	5.25	4.80	4.60	5.00	4.71	4.57	
EER (Water 7°C, Ambient 35°C)	Nominal	3.12	3.60	3.35	3.54	3.54	3.31	
Hot water energy rating (Profile L - 200l)		A+	A+	A+	A+	A+	A+	
Seasonal efficiency hot water, COP _{oHW} / ηs (Profile L - 200l)		3.30/132	3.30/132	3.30/132	3.25/130	3.25/130	3.25/130	
Hot water energy rating (Profile XL - 260l)		A+	A+	A+	A+	A+	A+	
Seasonal efficiency hot water, COP _{oHW} / ηs (Profile XL - 260l)		3.40/136	3.40/136	3.40/136	3.35/134	3.35/134	3.35/134	
Energy rating at 35°C	Medium climate	A+++	A+++	A+++	A+++	A+++	A++	
Seasonal efficiency at 35°C, SCOP / ηs		4.93/181	4.58/177	4.25/175	4.80/189	4.48/176	3.90/153	
Energy rating at 55°C		A++	A++	A++	A++	A++	A++	
Seasonal efficiency at 55°C, SCOP / ηs		3.58/133	3.38/130	3.25/125	3.50/137	3.43/134	3.23/126	
ESEER		3.36	3.26	3.26	3.33	3.29	2.84	
SEER / ηs	Single-phase	4.11/162	4.13/162	3.95/155	4.93/194	4.83/190	4.70/185	
	Three-phase	-	-	-	5.05/199	4.92/194	4.78/188	
Outdoor operating temperatures	Heating (DB) °C	-20 to 25	-20 to 25	-20 to 25	-25 to 25	-25 to 25	-25 to 25	
	Hot water (DB) °C	-20 to 35	-20 to 35	-20 to 35	-25 to 35	-25 to 35	-25 to 35	
	Cooling (DB) °C	10 to 46	10 to 46	10 to 46	10 to 46	10 to 46	10 to 46	
Water production temperatures	Heating °C	20 to 60	20 to 60	20 to 60	20 to 60	20 to 60	20 to 60	
	Hot water °C	30 to 75	30 to 75	30 to 75	30 to 75	30 to 75	30 to 75	
	Cooling °C	5 to 22	5 to 22	5 to 22	5 to 22	5 to 22	5 to 22	
Refrigerant pipe diameter	Liquid-gas inches	1/4-1/2	1/4-1/2	1/4-5/8	3/8-5/8	3/8-5/8	3/8-5/8	
Water pipe diameter	Input-output inches	1-1	1-1	1-1	1-1/4 - 1-1/4	1-1/4 - 1-1/4	1-1/4 - 1-1/4	
Hot water pipe diameter	Input-output inches	3/4-3/4	3/4-3/4	3/4-3/4	3/4-3/4	3/4-3/4	3/4-3/4	
Indoor unit			RWD-2.0NRW(S)E	RWD-2.5NRW(S)E	RWD-3.0NRW(S)E	RWD-4.0NW(S)E	RWD-5.0NW(S)E	RWD-6.0NW(S)E
Minimum water volume of the installation	l	28	28	28	38	46	55	
Water flow	(Min-Nom-Max) m ³ /h	0.50 - 0.77 - 1.80	0.60 - 1.03 - 1.90	0.60 - 1.03 - 1.90	1.00 - 1.89 - 2.70	1.10 - 2.41 - 2.80	1.20 - 2.75 - 2.80	
Emergency heating element in primary	Steps/Capacity n ^o /kW	3 / 1 - 1 - 1	3 / 1 - 1 - 1	3 / 1 - 1 - 1	3 / 2 - 2 - 2	3 / 2 - 2 - 2	3 / 2 - 2 - 2	
Hot water emergency heating element	Steps/Capacity n ^o /kW	1 / 2.7	1 / 2.7	1 / 2.7	1 / 2.7	1 / 2.7	1 / 2.7	
Sound power	dB(A)	37	37	37	39	39	39	
Dimensions (H (with connections) x W x D)	mm	1,750(1,816) x600x733	1,750(1,816) x600x733	1,750(1,816) x600x733	1,750(1,816) x600x733	1,750(1,816) x600x733	1,750(1,816) x600x733	
Tank weight 200l / 260l / 260l solar	kg	121/131/131	122/132/132	122/132/132	120/130/130	122/132/132	122/132/132	
Solar pipe diameter (260l solar tank)	Input-output inches	1/2-1/2	1/2-1/2	1/2-1/2	1/2-1/2	1/2-1/2	1/2-1/2	
Solar exchange surface (260l solar tank)	m ²	0.37	0.37	0.37	0.37	0.37	0.37	
Maximum current	Single-phase A	27	27	27	41.5	41.5	41.5	
	Three-phase A	-	-	-	22.4	22.4	22.4	
Outdoor unit			RAS-2WHVNRP	RAS-2.5WHVNRP	RAS-3WHVNRP	RAS-4WH(V)NPE	RAS-5WH(V)NPE	RAS-6WH(V)NPE
Air flow	m ³ /h	2,526	2,526	2,982	4,800	5,400	6,000	
Sound pressure	dB(A)	46	47	50	49	50	50	
Sound power	dB(A)	61	63	64	64	65	67	
Minimum pipe length	m	3	3	3	5	5	5	
Maximum pipe length	m	50	50	50	75	75	75	
Maximum height difference (highest OU/lowest OU)	m	30/20	30/20	30/20	30/20	30/20	30/20	
Compressor		Scroll DC Inverter	Scroll DC Inverter	Rotary DC Inverter	Scroll DC Inverter	Scroll DC Inverter	Scroll DC Inverter	
Refrigerant		R32	R32	R32	R410A	R410A	R410A	
Refrigerant charge (length without additional charge)	kg (m)	1.2 (10)	1.3 (10)	1.3 (10)	3.3 (15)	3.4 (15)	3.4 (15)	
Additional refrigerant charge	g/m	15	15	15	60	60	60	
Dimensions (H x W x D)	mm	600x792x300	600x792x300	600x792x300	1,380x950x370	1,380x950x370	1,380x950x370	
Weight	kg	45	45	44	103	103	103	
Maximum current	Single-phase/Three-phase	13/-	13/-	17/-	30/14	30/14	30/16	

Compatible controls and accessories:



Remote control
PC-ARFHE
Included

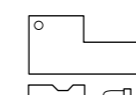

Cooling Kit
ATW-CKM-01
Can be used to switch machine operation to cold.

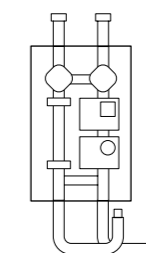

2nd temperature kit
ATW-2TK-06
Only compatible with built-in Yutaki S Combi 200L.

ATW-2TK-07
For wall-mounting. Compatible with the entire Yutaki range

Internal design

Yutaki S Combi

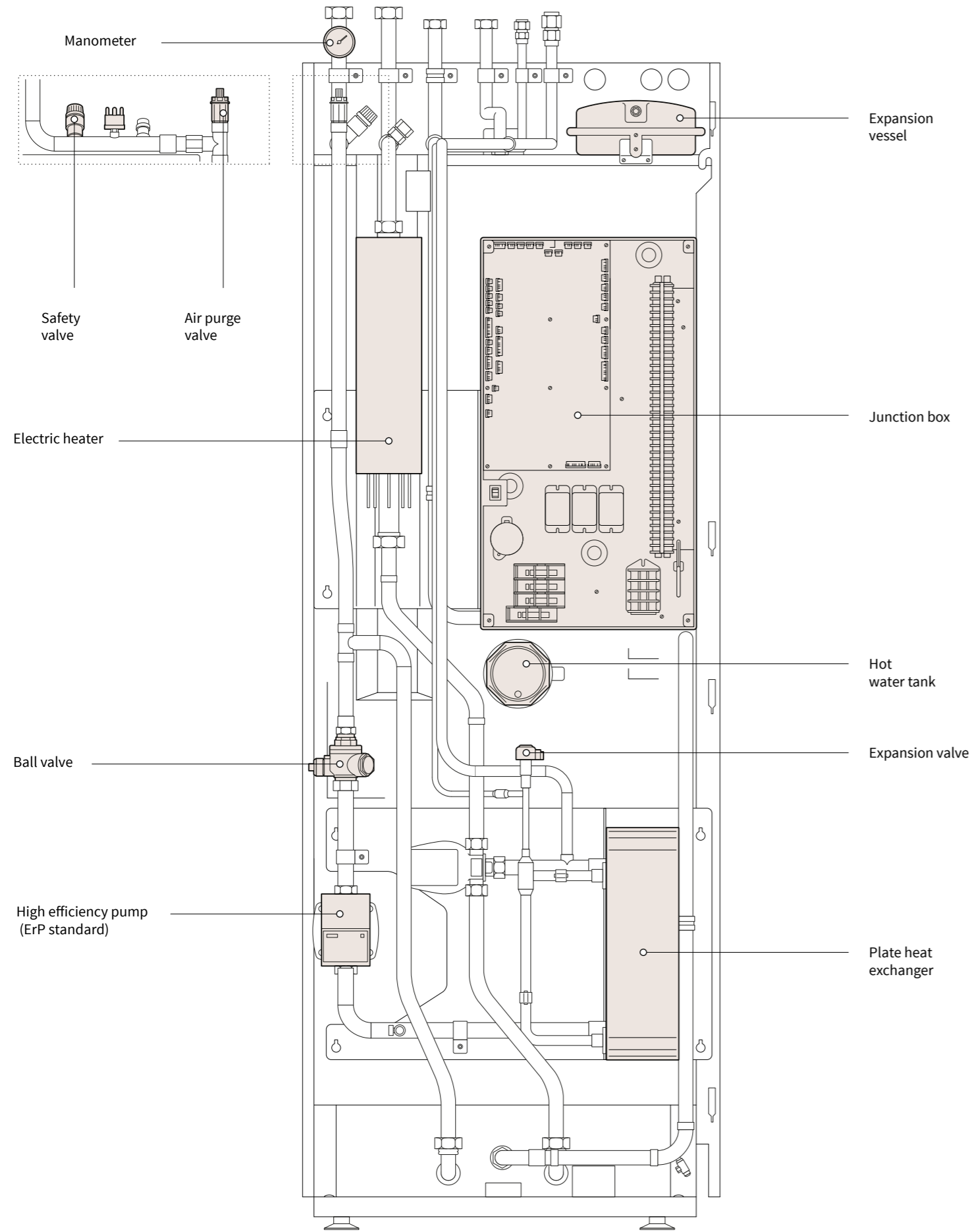

Configurations

Radiator and underfloor heating at the same temperature; one zone + hot water by built-in tank.

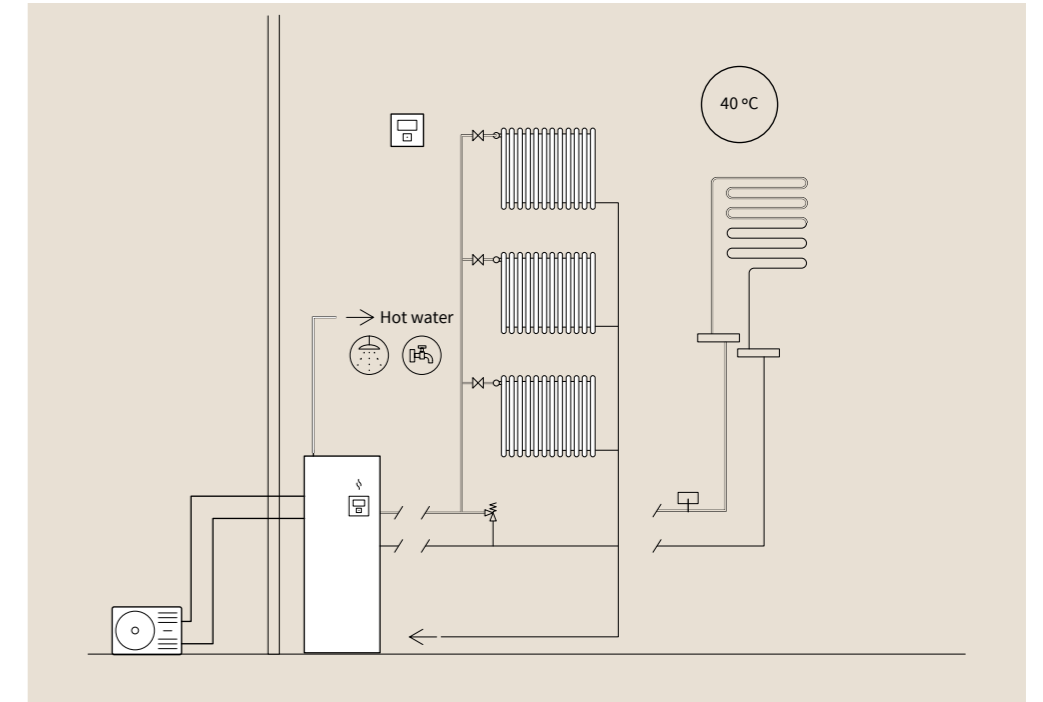

Radiator and underfloor heating at different temperatures; two zones + hot water by built-in tank.

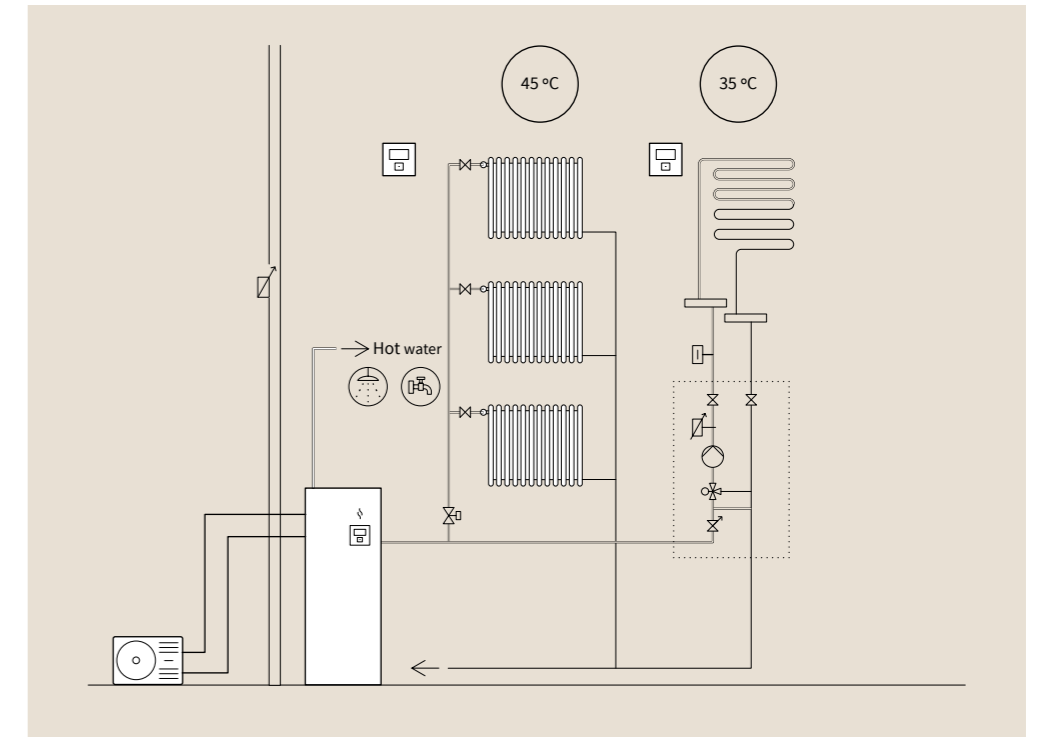

Yutaki ASHP



Yutaki S80

Water temperature up to 80 °C for heating and hot water without an electric heater

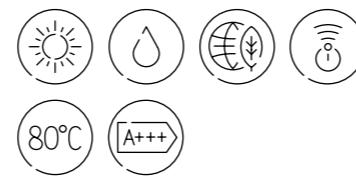

Maximum efficiency with smart cascade cycle

Yutaki S80 uses two refrigerants: R410A and R134a. Thanks to the unique **Smart Cascade cycle**, the equipment automatically adjusts operation according to heating requirements. When the heating requirement is lower (water temperature up to 53 °C), it only uses the R410A refrigerant; when this requirement increases (water temperature up to 80 °C), it activates the second cycle of R134a refrigerant. Consumption is under control and comfort is guaranteed at all times. (Fig. 1)

Maximum heating capacity

It can heat water up to 80°C using renewable energy, even at extreme temperatures down to -25°C.

Easy installation and maintenance

Its design allows easy access to the water and refrigerant connections, which are fitted in the top of the indoor unit and at the back of the tank unit.

Fig. 1: Smart Cascade cycle configuration

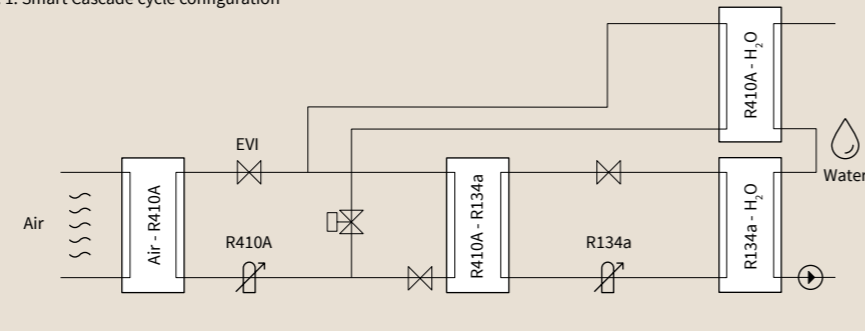

Adapted to each installation

The Yutaki S80 is available in two models, adapting to any needs which may arise: one for heating, and one for heating and hot water.

There are two tanks, with 200 and 260-litre capacity, that can be installed as a built-in unit on or next to the indoor unit. (Fig. 2)*

Fig. 2

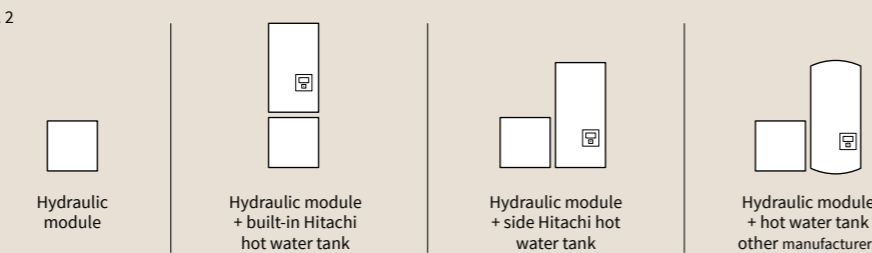

Indoor units

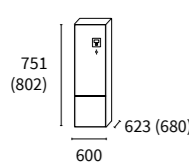

Outdoor units

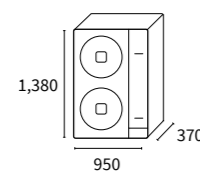

RWH-4.0VNFWE
RWH-5.0VNFWE
RWH-6.0VNFWE

RWH-4.0VNFWE
RWH-5.0VNFWE
RWH-6.0VNFWE

RAS-4WH(V)NPE
RAS-5WH(V)NPE
RAS-6WH(V)NPE

* Two tank options not available in the UK

Yutaki S80

System		Yutaki S80 4	Yutaki S80 5	Yutaki S80 6
Capacity	Heating (Min/Nom/Max) kW	4.30/11.00/15.20	4.80/14.00/16.70	5.50/16.00/17.80
Consumption	Heating (Nom) kW	2.12	2.90	3.43
Electrical power		1 ~230V 50Hz	1 ~230V 50Hz	1 ~230V 50Hz
		3N ~400V 50 Hz	3N ~400V 50 Hz	3N ~400V 50 Hz
COP	Nominal	5.00	4.71	4.57
Energy rating at 35°C		A+++	A++	A++
Seasonal efficiency at 35°C, SCOP / ηs	Medium climate	4.75/187	4.43/174	3.88/152
Energy rating at 55°C		A++	A++	A++
Seasonal efficiency at 55°C, SCOP / ηs		3.63/142	3.35/131	3.23/126
Outdoor operating temperatures	Heating (DB) °C	-25 to 25	-25 to 25	-25 to 25
	Hot water (DB) °C	-25 to 35	-25 to 35	-25 to 35
Water production temperatures	Heating °C	20 to 80	20 to 80	20 to 80
	Hot water °C	30 to 75	30 to 75	30 to 75
Refrigerant pipe diameter	Liquid-gas inches	3/8-5/8	3/8-5/8	3/8-5/8
Water pipe diameter	Input-output inches	1-1/4 - 1-1/4	1-1/4 - 1-1/4	1-1/4 - 1-1/4
Hot water pipe diameter	Input-output inches	3/4-3/4	3/4-3/4	3/4-3/4
Indoor unit (without tank)		RWH-4.0VNFWE	RWH-5.0VNFWE	RWH-6.0VNFWE
Indoor unit (with hot water tank)		RWH-4.0VNFWE	RWH-5.0VNFWE	RWH-6.0VNFWE
Minimum water volume of the installation	l	40	50	50
Water flow	(Min/Nom/Max) m ³ /h	1.00 - 1.26 - 2.80	1.10 - 1.64 - 3.20	1.20 - 1.83 - 3.20
Sound power	dB(A)	57	57	58
Refrigerant		R-134A	R-134A	R-134A
Refrigerant charge	kg	1.90	1.90	1.90
Compressor		Scroll DC Inverter	Scroll DC Inverter	Scroll DC Inverter
Dimensions model S80 (H (with connections) x W x D)	mm	751(802)x600x623	751(802)x600x623	751(802)x600x623
Dimensions model S80 COMBI (H x W x D (with connections))	mm	751x600x623(680)	751x600x623(680)	751x600x623(680)
Model weight without tank	Single-phase kg	125	129	129
	Three-phase kg	127	136	136
Model weight with tank	Single-phase kg	135	139	139
	Three-phase kg	137	146	146
Maximum current	Single-phase	36	40	43
	Three-phase	22	22	22
Outdoor unit		RAS-4WH(V)NPE	RAS-5WH(V)NPE	RAS-6WH(V)NPE
Air flow	m ³ /h	4,800	5,400	6,000
Sound pressure	dB(A)	49	50	50
Sound power	dB(A)	61	63	64
Minimum pipe length	m	5	5	5
Maximum pipe length	m	75	75	75
Maximum height difference (highest OU/lowest OU)	m	30/20	30/20	30/20
Compressor		Scroll DC Inverter	Scroll DC Inverter	Scroll DC Inverter
Refrigerant		R410A	R410A	R410A
Refrigerant charge (length without additional charge)	kg (m)	3.3 (15)	3.4 (15)	3.4 (15)
Additional refrigerant charge	g/m	60	60	60
Dimensions (H x W x D)	mm	1,380x950x370	1,380x950x370	1,380x950x370
Weight	kg	103	103	103
Maximum current	Single-phase	20	25	25
	Three-phase	14	14	16
Outdoor unit	Single-phase £	2,665	2,928	3,311
	Three-phase £	2,851	3,095	3,499
Indoor unit	Single-phase £	5,075	5,482	5,961
	Three-phase £	5,638	5,991	6,627

*The control must be purchased when installing the tankless version.

Compatible controls and accessories:

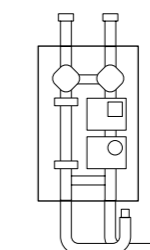
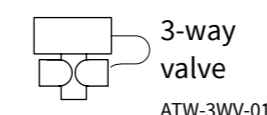
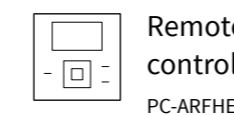

2nd temperature kit
ATW-2T-07
For wall-mounting

Others:
- Heating element. WEH-6E. Price: £660
- Kit for installation with tank next to the S80 indoor unit. mod. ATW-FWP-02

Internal design

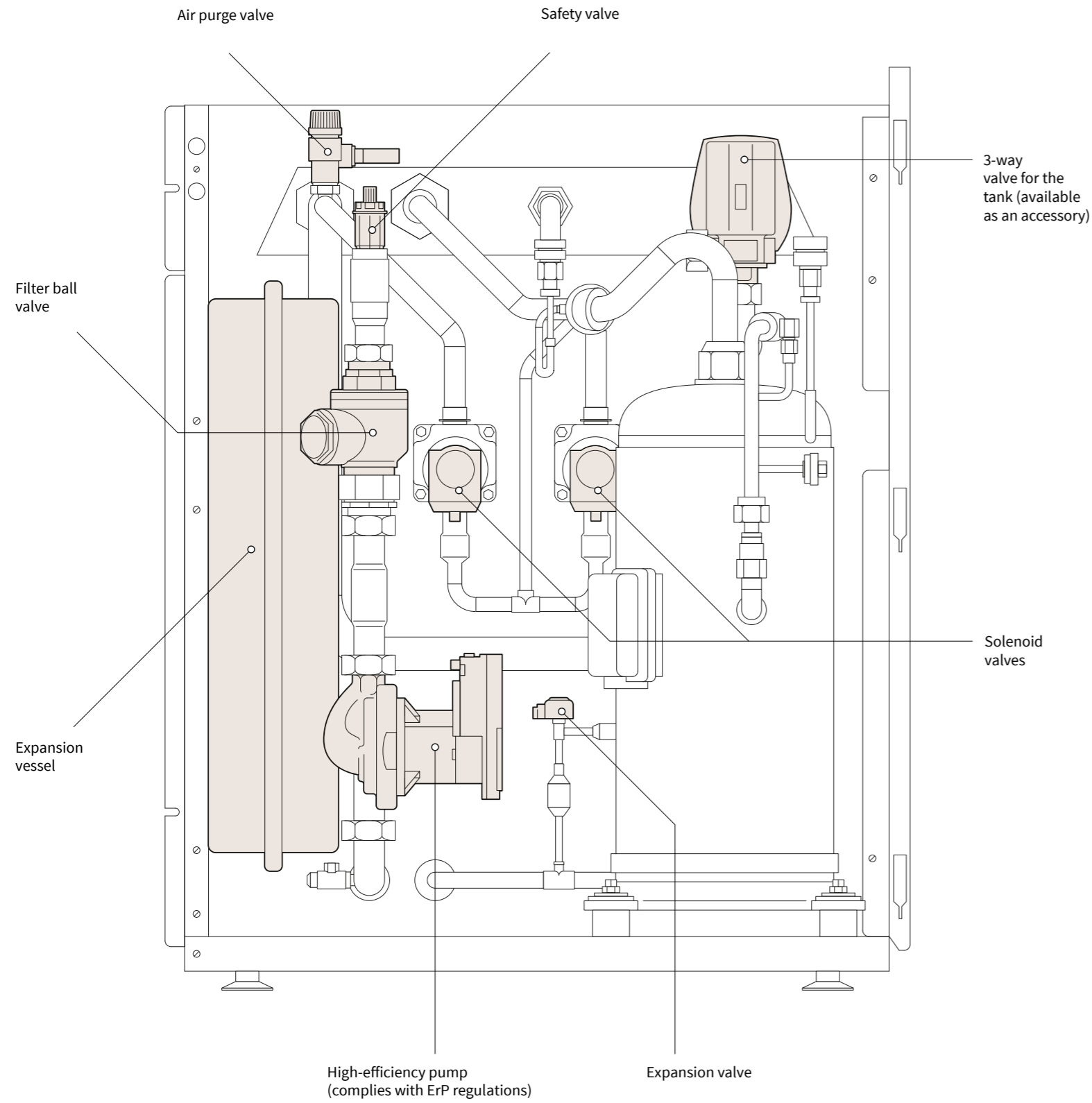

Its flexible design allows different installation possibilities and flexible pipe connection.

- Hydraulic module.
- Hydraulic module + built-in Hitachi hot water tank (not available in the UK).
- Hydraulic module + Hitachi hot water tank on one side (not available in the UK).
- Hydraulic module + third-party hot water tank.

Configurations

Heating, one circuit.

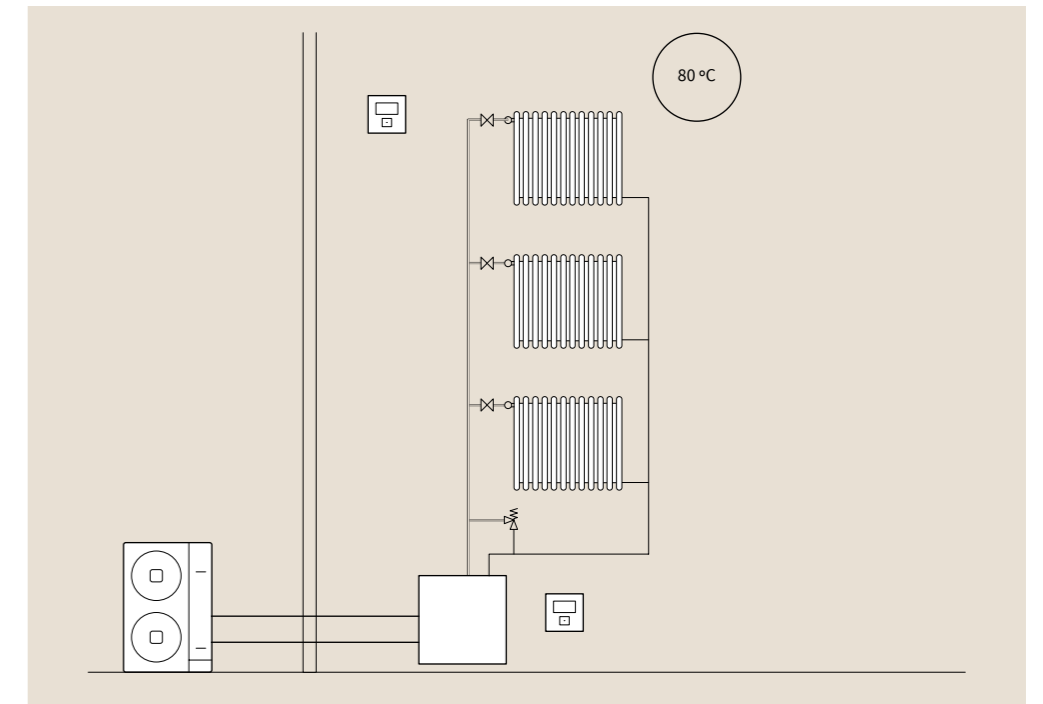

Heating, radiators and underfloor heating at different temperatures; two zones.

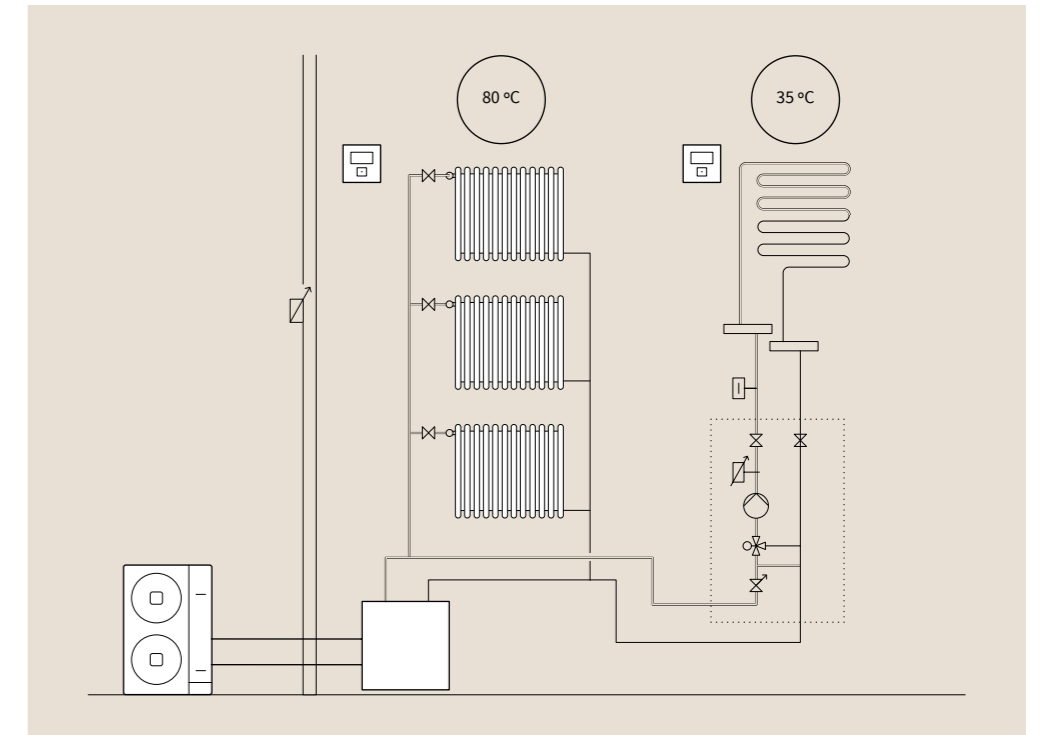

Heating, cascade operation.

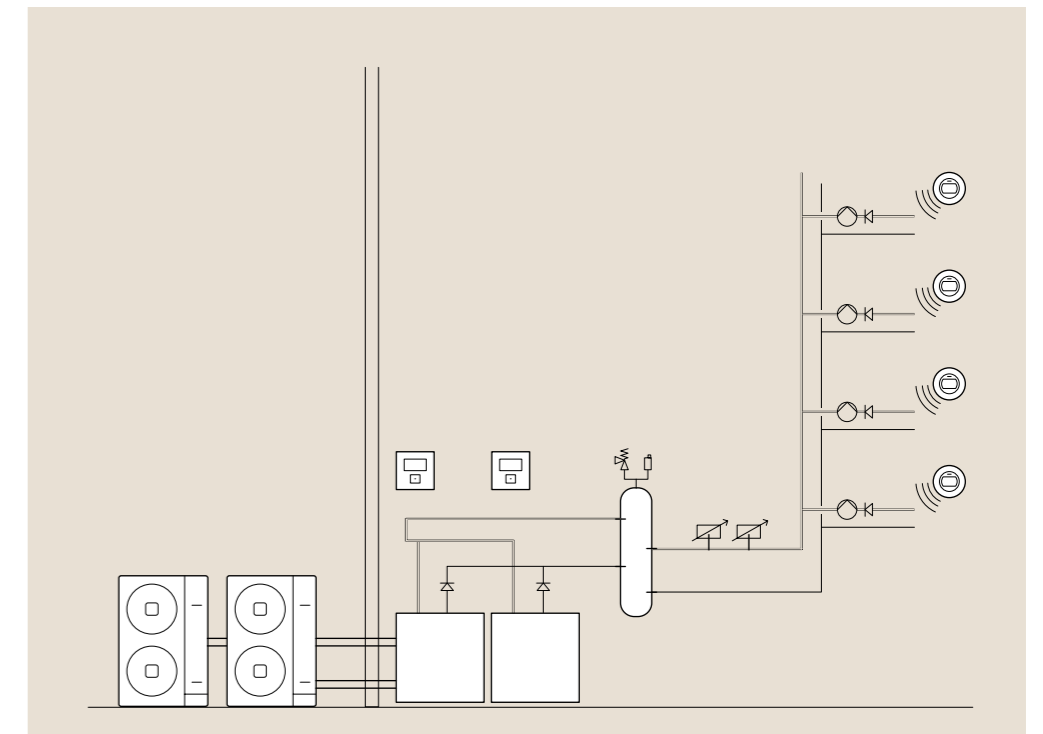

Yutaki M

Compact unit for heating, hot water and cooling without refrigeration connections



Perfect for small spaces

The Hitachi monobloc system is designed for installation in any type of property, especially homes with limited space.

Being a compact system with a single unit installed outdoors means the available space indoors remains unchanged.

Easy to install

The monobloc system ensures all functions are achieved with a single outdoor unit, bringing significant cost savings. Furthermore, installation time is much shorter since practically no pipes are required, there are no cooling connections, and the product is pre-charged at the factory.

Heating and cooling in a single system all year round

By combining the Yutaki M and the **Cooling Kit**, the accessory used to reverse heat pump operation ensures maximum comfort can be enjoyed all year round. The system therefore offers heating in winter and cooling in summer, all with straightforward installation.

Easy, smart control

The control with LCD screen can be used for daily and weekly programming, managing water production temperature, operating modes, etc. (Fig. 1)

Fig. 1

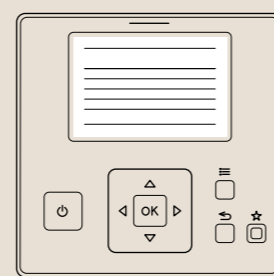

PC-ARFHE control

Outdoor units

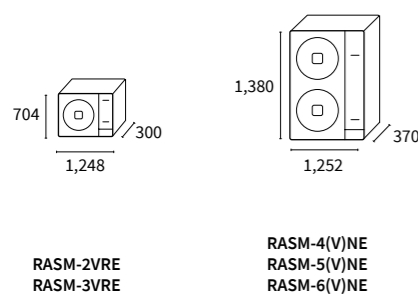

Yutaki M

Name of the system			Yutaki M 2	Yutaki M 3	Yutaki M 4	Yutaki M 5	Yutaki M 6
Outdoor unit			RASM-2VRE	RASM-3VRE	RASM-4(V)NE	RASM-5(V)NE	RASM-6(V)NE
Capacity	Heating (Min/Nom/Max)	kW	1.85/4.30/6.50	2.1/8.00/11.00	4.30/11.00/15.20	4.80/14.00/16.70	5.50/16.00/17.80
	Cooling (Nom/Max)	kW	4.00/5.00	6.50/7.00	7.20/11.80	9.50/12.60	10.50/13.70
Consumption	Heating (Nom)	kW	0.82	1.74	2.20	2.97	3.50
	Cooling (Nom)	kW	1.00	1.94	2.18	2.68	3.17
Electrical power	Single-phase		1 ~230V 50Hz	1 ~230V 50Hz	1 ~230V 50Hz	1 ~230V 50Hz	1 ~230V 50Hz
	Three-phase		-	-	3N ~400V 50 Hz	3N ~400V 50 Hz	3N ~400V 50 Hz
COP (Water 35°C, Ambient 7°C)	Nominal		5.25	4.60	5.00	4.71	4.57
EER (Water 7°C, Ambient 35°C)	Nominal		4.00	3.35	3.54	3.54	3.31
Energy rating at 35°C			A+++	A+++	A+++	A+++	A++
Seasonal efficiency at 35°C, SCOP / ηs			4.93/181	4.25/177	4.75/187	4.45/175	3.90/153
Energy rating at 55°C			A++	A++	A++	A++	A++
Seasonal efficiency at 55°C, SCOP / ηs	Medium climate		3.58/133	3.25/125	3.48/136	3.40/133	3.30/125
ESEER			3.36	3.26	3.33	3.29	2.84
SEER / ηs	Single-phase		4.11/162	3.95/155	4.93/194	4.83/190	4.70/185
	Three-phase		-	-	5.05/199	4.92/194	4.78/188
Outdoor operating temperatures	Heating (DB)	°C	-20 to 25	-20 to 25	-25 to 25	-25 to 25	-25 to 25
	Hot water (DB)	°C	-20 to 35	-20 to 35	-25 to 35	-25 to 35	-25 to 35
	Cooling (DB)	°C	10 to 46	10 to 46	10 to 46	10 to 46	10 to 46
Water production temperatures	Heating	°C	20 to 60	20 to 60	20 to 60	20 to 60	20 to 60
	Hot water	°C	30 to 75	30 to 75	30 to 75	30 to 75	30 to 75
	Cooling	°C	5 to 22	5 to 22	5 to 22	5 to 22	5 to 22
Maximum current	Single-phase		12.7	17.2	30.8	30.8	30.8
	Three-phase		-	-	14.3	14.3	16.3
Water pipe diameter	Input-output	inches	1-1	1-1	1-1/4 - 1-1/4	1-1/4 - 1-1/4	1-1/4 - 1-1/4
Minimum water volume of the installation		l	28	28	38	46	55
Water flow	(Min/Nom/Max)	m3/h	0.50 - 0.77 - 1.90	0.60 - 1.29 - 2.10	1.00 - 1.89 - 2.80	1.10 - 2.41 - 3.00	1.20 - 2.75 - 3.00
Air flow		m3/h	2,526	2,982	4,800	5,400	6,000
Sound power		dB(A)	61	69	64	65	69
Compressor			Scroll DC Inverter	Rotary DC Inverter	Scroll DC Inverter	Scroll DC Inverter	Scroll DC Inverter
Refrigerant			R32	R32	R410A	R410A	R410A
Refrigerant charge		kg (m)	1.20	1.30	2.80	3.10	3.10
Dimensions (H x W x D)		mm	704 x 1,248 x 300	704 x 1,248 x 300	1,380x1,252x370	1,380x1,252x370	1,380x1,252x370
Weight	Single-phase	kg	76	78	131	133	133
	Three-phase		-	-	130	132	132

*The control must be purchased for operation.

Compatible controls and accessories:

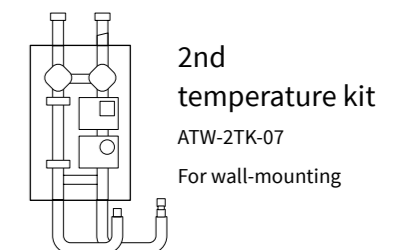
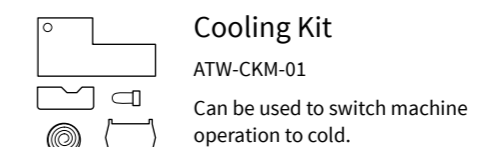
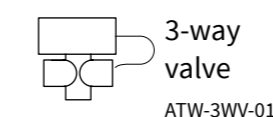
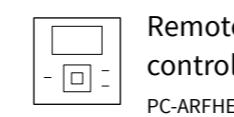

Internal design

Yutaki M

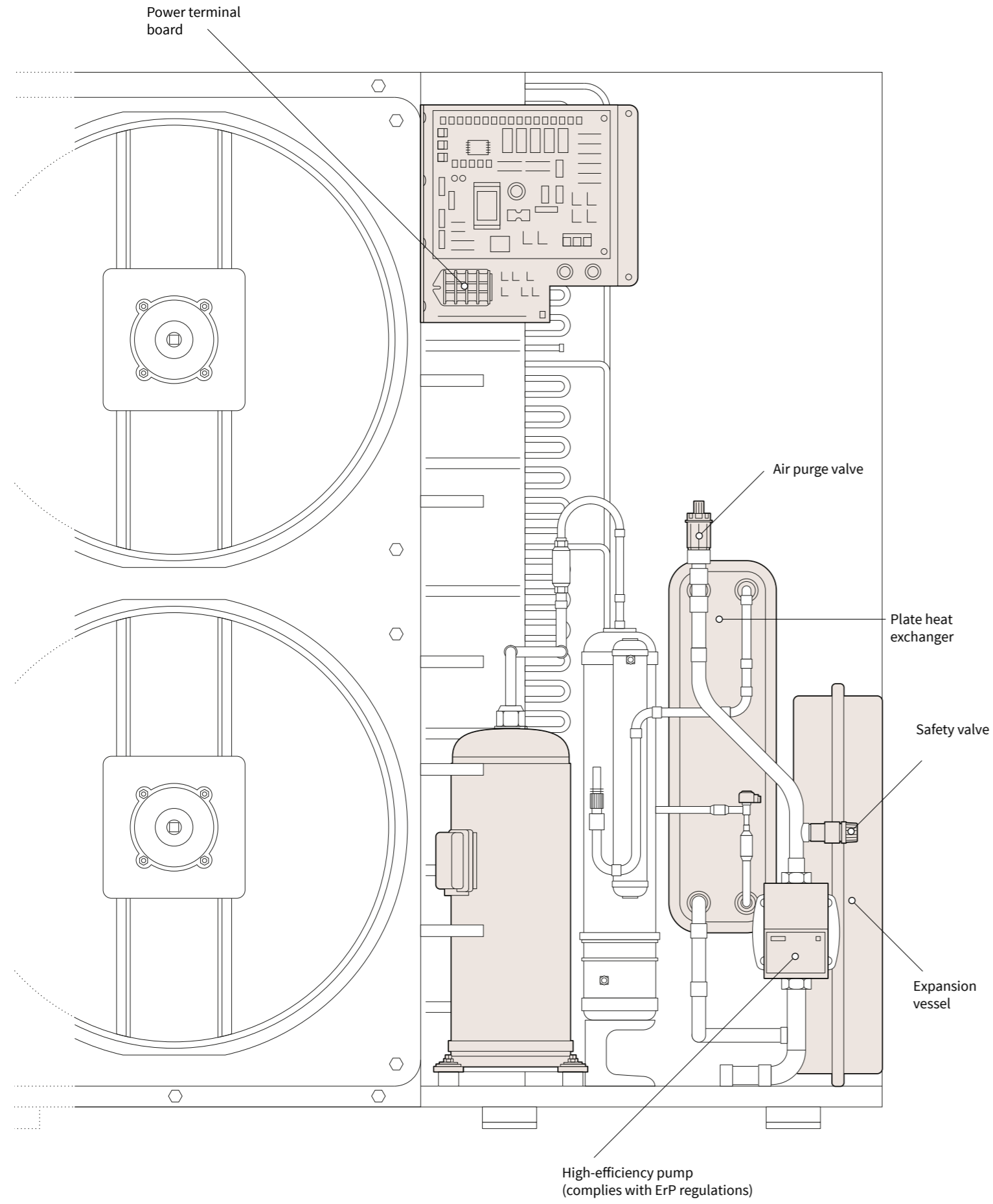

Configurations

Radiator and underfloor heating at the same temperature; one zone + hot water by external tank.

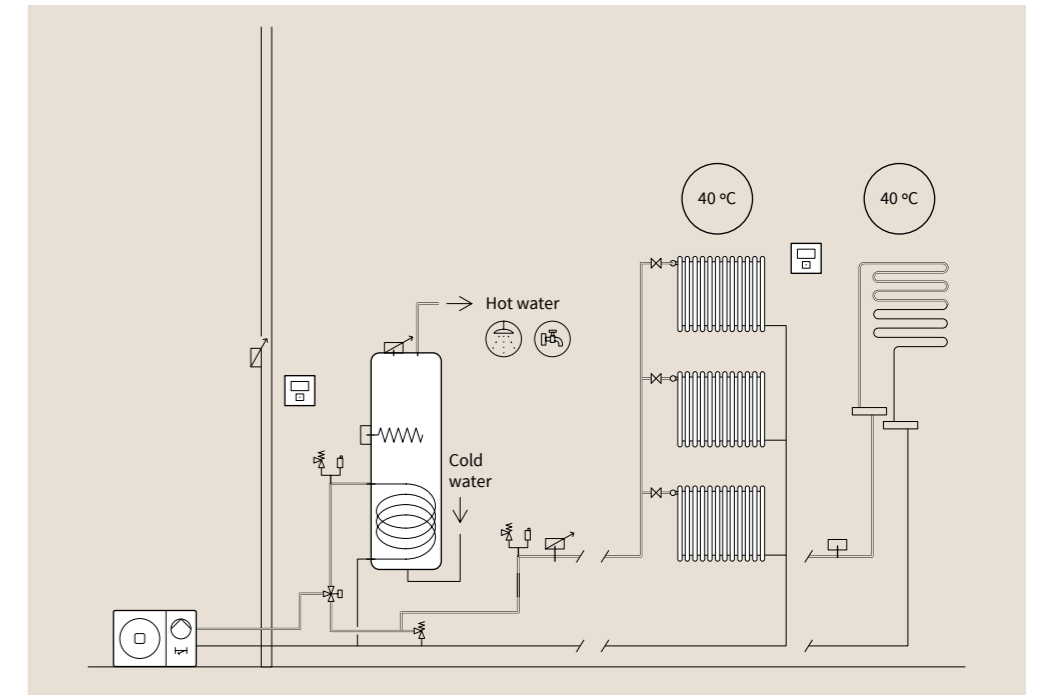

Yutaki ASHP

Radiator and underfloor heating at different temperatures; two zones + hot water by external tank.

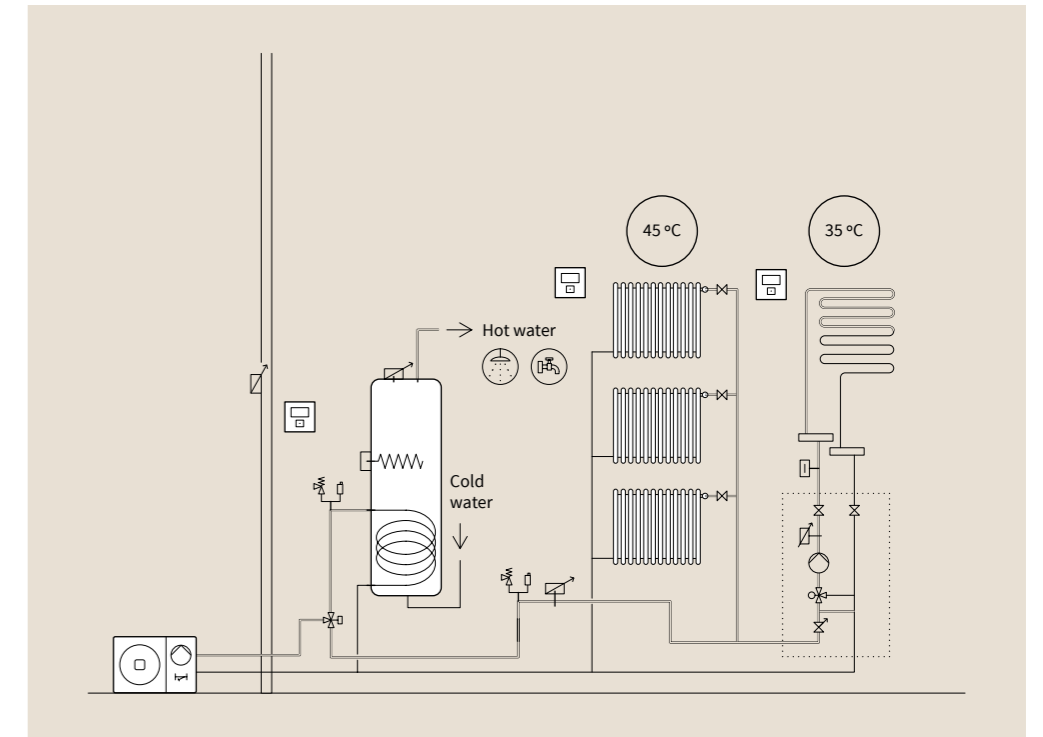

Yutaki T

The simplest and most economical way to produce hot water



Maximum comfort, minimum consumption

The unit absorbs heat from the outdoor air, and transfers it to the tank to heat the water up to 55 °C. This achieves **savings of 70%** compared to traditional heaters.

Greater durability

Yutaki tanks are now coated with duplex stainless steel, a material that offers greater resistance to high temperatures and corrosion.

More ecological

By using renewable energy to heat the water, it does not emit CO₂, and allows smart management of operation thanks to the weekly programmable clock.

Bespoke tank

The Yutaki T range is made up of two models, 190 and 270 litre-capacity, tailored to the needs of each home. The compact 190 litre model can be installed in standard 600 x 600 mm cabinets. It is now also 10 kilos lighter and has a refrigerant coil on the outside, thus increasing the volume of refrigerant.

Control operation from anywhere

The smart function allows operation to be programmed in advance, bringing significant savings in consumption. It can also be connected to MODBUS for home automation.

Error identifier

The equipment has a self-diagnostic system, allowing errors to be identified easily thanks to the flashing LED on the indoor and outdoor units.

Yutaki T configuration

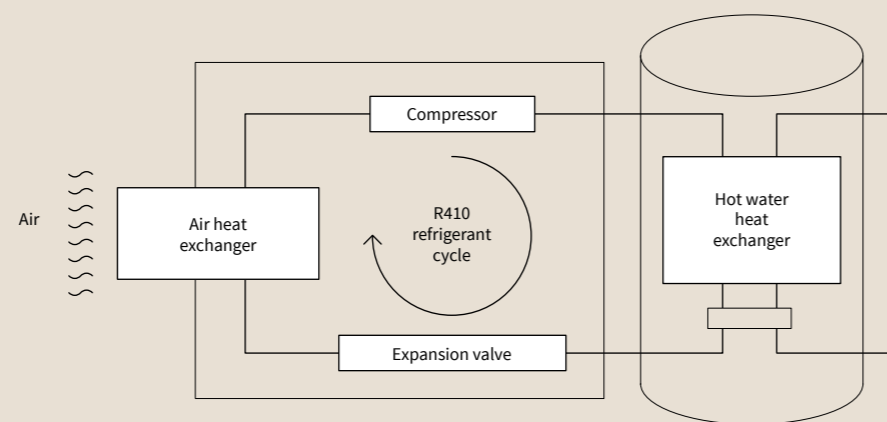

Hot water tank

Outdoor units

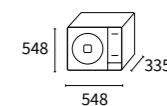
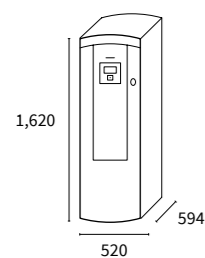

TAW-190NHB
TAW-270NHB

RAW-35NHB

* Product range is not currently available in the UK.

Yutaki T

Hot water tank			TAW-190NHB	TAW-270NHB
Capacity	l		190	270
Hot water energy rating			A+	A+
Seasonal efficiency hot water, COP DHW /ηs	Medium climate		3.10/123	3.20/125
Material			Duplex stainless steel	Duplex stainless steel
Declared charge profile			L	XL
Energy consumed in standby mode	kWh		24.90	20.00
Maximum volume of usable water (At 40°C)	l		256	356
Heating time	h:min		3:15	3:35
Maximum water temp. (with heating element)	°C		55 (75)	55 (75)
Electrical power			1 ~230V 50Hz	1 ~230V 50Hz
Electrical power	Liquid-gas	inches	1/4-3/8	1/4-3/8
Hot water pipe diameter	Input-output	inches	3/4-3/4	3/4-3/4
Dimensions (H x W x D)	mm		1,620x520x594	1,620x600x674
Weight	Kg		49	54
Outdoor unit			RAW-35NHB	RAW-35NHB
Air flow	m ³ /h		1,620	1,620
Sound power	dB(A)		63	63
Minimum pipe length	m		5	5
Maximum pipe length	m		20	20
Maximum height difference-highest OU	m		10	10
Outdoor operating temperatures	Hot water (DB)	°C	-15 to 37	-15 to 37
Compressor			Rotary	Rotary
Refrigerant			R410A	R410A
Refrigerant charge (length without additional charge)	kg (m)		1.2 (20)	1.2 (20)
Additional refrigerant charge	g/m		not required	not required
Dimensions (H x W x D)	mm		548x841x335	548x841x335
Weight	kg		33	33
Electrical power			1 ~230V 50Hz	1 ~230V 50Hz

Compatible controls and accessories:



Hi-Kumo

Internal design

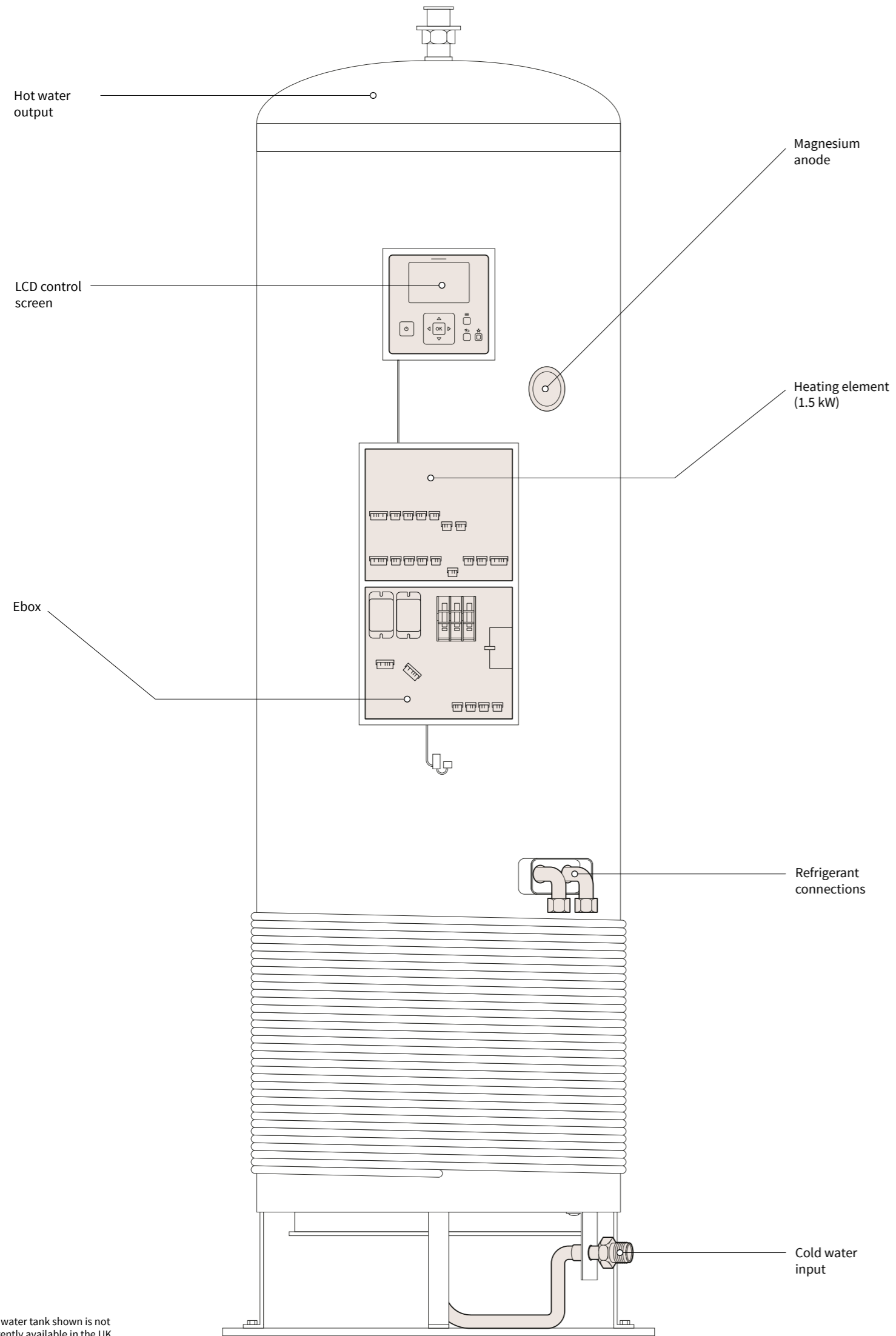

Hot water tank shown is not currently available in the UK



Controls

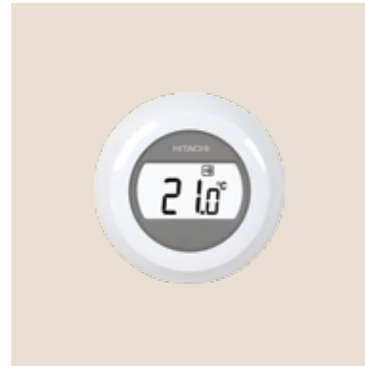

Wireless thermostat ON/OFF
ATW-RTU-04

- Includes receiver.
- ON/OFF function.
- Easy to install.

Compatibility: Entire Yutaki range.



Smart wireless thermostat
ATW-RTU-05

- Includes receiver.
- Multifunction.
- Easy to install.

Compatibility: Entire Yutaki range.

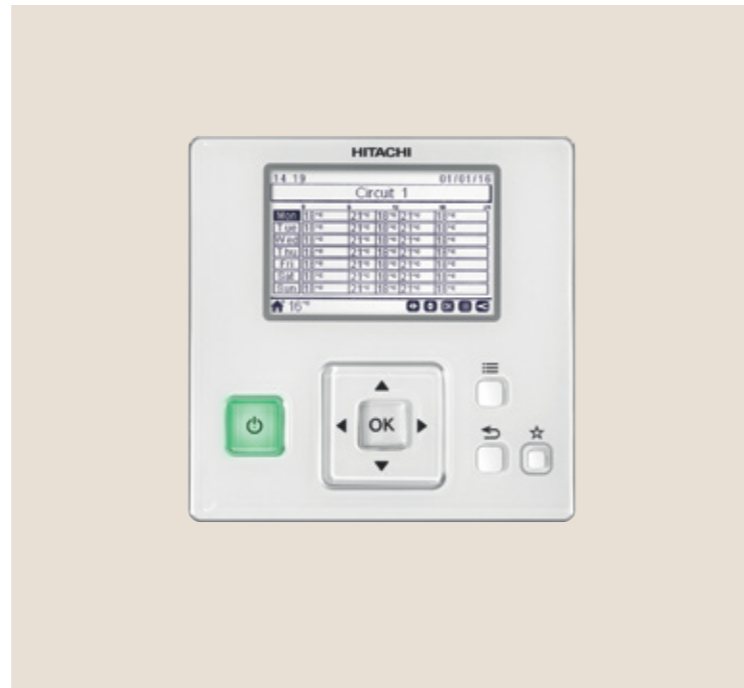

Wired control
PC-ARFHE

- Weekly programming.
- Multifunction: modes, temperatures.
- Eco mode.
- Configure, set and display operating parameters.
- Several languages.
- Can work as a thermostat.
- On-screen error codes.

Compatibility: Entire Yutaki range.



Wireless thermostat for second circuit
ATW-RTU-06

- Multifunction.
- Easy to install.
- To control the temperature of a second circuit.

Compatibility: Entire Yutaki range.



KNX Interface
ATW-KNX-02

- Centralises the control.
- Allows the Yutaki range to be integrated in KNX home automation systems.

Compatibility: Entire Yutaki range.



Modbus for Yutaki
ATW-MBS-02

- Centralises the control.
- Allows the Yutaki range to be integrated in Modbus systems.

Compatibility: Entire Yutaki range.

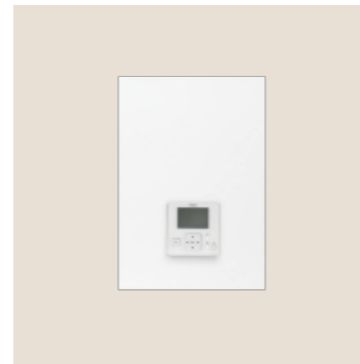

Cascade control
ATW-YCC-01

- Suitable for high power installations.
- Centralised control of up to 8 Yutaki units.
- Different control options: cascade, rotary, smart defrost...

Compatibility: The entire Yutaki range except for Yutaki T.



Wi-Fi adapter for Hi-Kumo app
ATW-TAG-02

- Connect the Yutaki range using the Hi-Kumo app in order to manage it from any mobile device.
- Requires Hi-Box AHP-SMB-01.



Hi-Box Yutaki
AHP-SMB-01

- Accessory for the ATW-TAG-02 Wi-Fi adapter.
- Ensures compatibility with the Hi-Kumo app, in order to manage the Yutaki system from any mobile device.

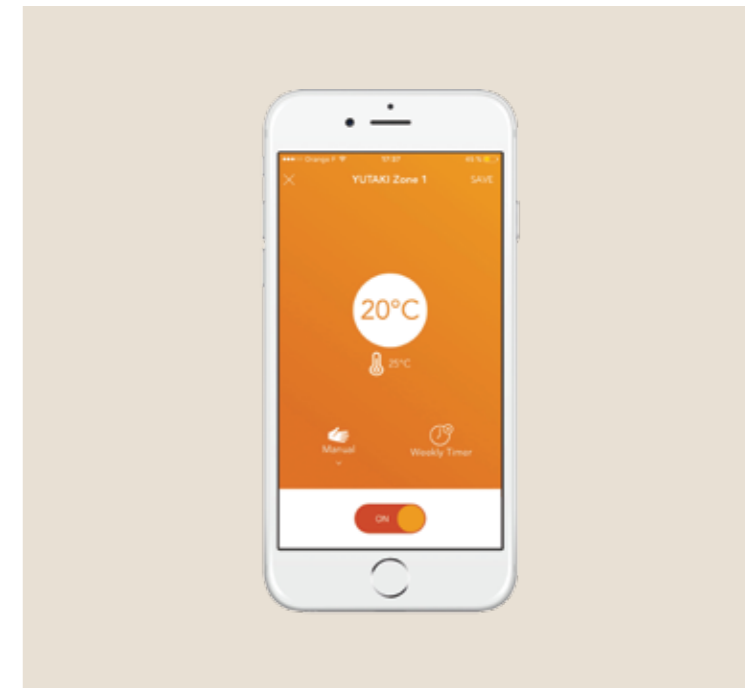

How to enjoy Hi-Kumo

1. Connect the Hi-Box to the router and the adapter to the Yutaki.
2. Download the app to your smartphone, tablet or computer.
3. Configure by simply searching for connected units and pairing them with the app.

Accessories

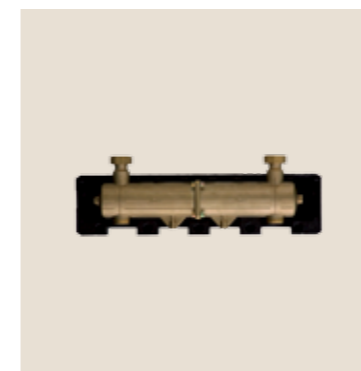

Hydraulic separator
ATW-HSK-01

- Non-corrosive (brass).
- 4 connection paths.
- With insulation.

Compatibility: Entire Yutaki range.



Second temperature kit
ATW-2TK-06

- Incorporated into 200 L hot water tank.

Compatibility: Yutaki S Combi with 200 L hot water tank.



Second temperature kit
ATW-2TK-07

- Wall-mounted model.

Compatibility: Entire Yutaki range.



Safety aquastat
ATW-AQT-01

- Recommended for underfloor heating applications.

Compatibility: Entire Yutaki range.



3-way valve
ATW-3WV-01

- Valve to allow operation in heating/hot water.

Compatibility: Entire Yutaki range.



Proportional discharge valve
ATW-DPOV-01

- Proportional for variable flow installations.
- Included as standard in UK version tanks.

Compatibility: Entire Yutaki range.



Second outdoor ambient temperature sensor
ATW-2OS-02

- Used to measure outside temperatures in the area where the outdoor unit is installed.

Compatibility: Entire Yutaki range.



Wired wall-mounted sensor for indoor ambient temperature
ATW-ITS-01

Compatibility: Entire Yutaki range.

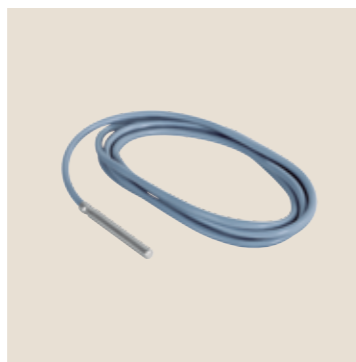

Universal water temperature sensor
ATW-WTS-02Y

Compatibility: Entire Yutaki range.



Backup heating element
WEH-6E

- 6 kW single/three phase.
- 3 x 2 kW stages.
- Built-in power relay.
- Steel body with external insulation.

Compatibility: Yutaki S80, Yutaki M.



Unit controller cover
ATW-FCP-01

- Used to cover the gap left in the indoor unit when removing the programmer control and using it as a thermostat in any area.

Compatibility: Entire Yutaki range.



Mirror box
ATW-YMM-01

- Simplifies installation when the Yutaki M is far from the property, avoiding the need to install large cable runs, using just two communication cables.

Compatibility: Yutaki M.

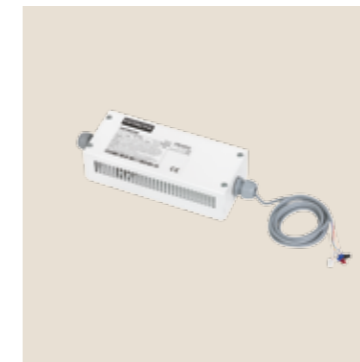

Auxiliary output signal box
ATW-AOS-02

- Relay box for additional output signals.

Compatibility: Entire Yutaki range.



Yutaki Range Cooling Kit
ATW-CKS-01/ATW-CKS-02/ATW-CKS-03/ATW-CKSC-01/ATW-CKM-01

- Used to switch the Yutaki range to work in both heat and cold.

ATW-CKS-01 (Yukaki S 2-3HP):
ATW-CKS-02 (Yukaki S 4-6HP):
ATW-CKS-03 (Yukaki S 8-10HP):
ATW-CKSC-01 (Yukaki S Combi):
ATW-CKM-01 (Yukaki M):
Compatibility: The entire range except for Yutaki S80.



Domestic hot water tank 200/300 L
DHWT-200/300 S-3.0H2E

Compatibility: Yutaki S, Yutaki S80, Yutaki M.

Hitachi tanks not currently available in the UK. G3 compliant Kingspan DHW cylinders are optional - speak to your Hitachi area sales manager or distributor for details.

Hot water tanks

			DHWT200S-3.0H2E	DHWT300S-3.0H2E
Water accumulator	Volume	L	200	300
	Maximum temperature	°C	75	75
	Maximum pressure	bar	10	10
Water heat exchanger	Maximum coil temperature	°C	99	99
	Maximum coil pressure	bar	10	10
	Exchanger surface	m ²	1.4	1.8
Type of insulation	Polyurethane	mm	50	50
Auxiliary heating element	Power	kW	3	3
Hydraulic connection	In DHW	inches	3/4 (f)	3/4 (f)
	Out DHW	inches	3/4 (f)	3/4 (f)
	Recirculation DHW	inches	3/4 (f)	3/4 (f)
	In coil water	inches	3/4 (f)	3/4 (f)
	Out coil water	inches	3/4 (f)	3/4 (f)
Accessories	Thermometer		Yes	Yes
	Safety thermostat		Yes	Yes



Domestic hot water tank 200 and 260 L
DHWS200/260 S-2.7H2E

Compatibility: Yutaki S80.

			DHWS200S-2.7H2E	DHWS260S-2.7H2E
Power			1 ~ 230 V 50 Hz	1 ~ 230 V 50 Hz
Dimensions	Separate tank height (Built-in tank height)	mm	1282 (1980) *	1591 (2289) *
	Width	mm	600	600
	Depth (with connections)	mm	648 (675)	648 (675)
Weight	kg		62	81
Net capacity	L		200	260
Maximum operating temperature			75	75
Pipe diameter	Water input	inches	G 3/4 male	G 3/4 male
	Water output	inches	G 3/4 male	G 3/4 male
Wired control			PC-ARFHE	PC-ARFHE

Hot water tank shown is not currently available in the UK

Hitachi's new R32 systems are the answer to an increasingly sustainable world and our commitment to the environment. We have been preparing for this change since 2013 by developing R32 equipment in Japan. Our new systems comply with F-GAS regulations and are designed to create harmony between people and their environments.



R32 1x1 Systems

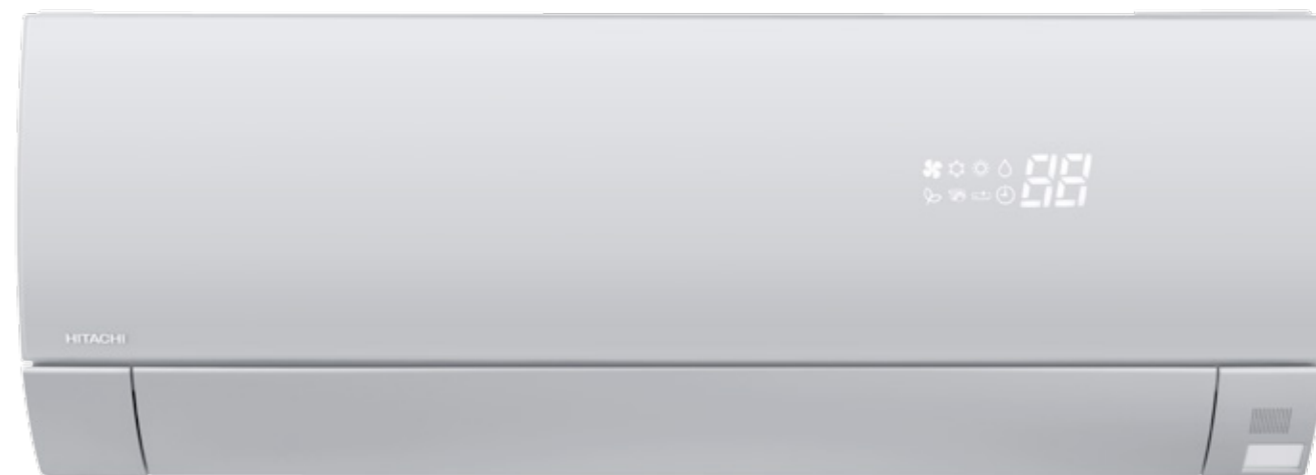

Discover Hitachi's new R32 range, designed to meet your home and business climate control needs

Summit



Performance



Light Commercial Wall-Mounted



Shirokuma



S-Premium white

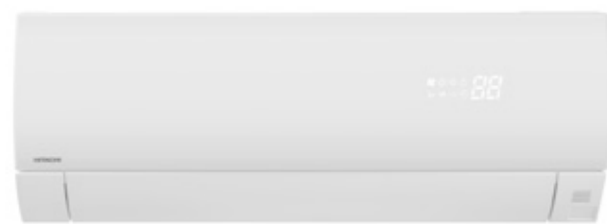

S-Premium silver





Light Commercial Cassette



Light Commercial Ducts

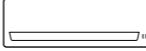
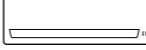
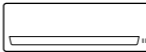
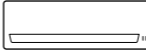
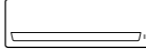
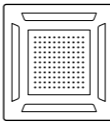

Quick selection table

	Nominal cooling powers (kW)							SCOP	SEER
	2	2.5	3.5	4.2	5	6	7		
Summit 	•	•	•		•			4.30	6.10
Performance 	•	•	•	•	•			4.90	8.50
Light Commercial Wall-Mounted 					•	•	•	4.61	7.40
Shirokuma 	•		•		•			5.20	8.70
S-Premium 		•	•		•			5.10	9.00
Light Commercial Cassette 		•	•		•	•		4.40	6.50
Light Commercial Ducts 		•	•		•	•	•	4.30	6.50

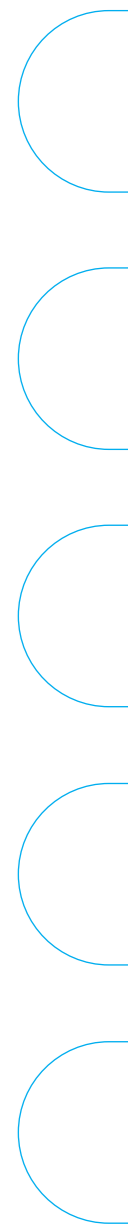

Benefits

R32



1 New regulation, new R32 refrigerant for a sustainable environment



European regulation F-GAS (517/2014) came into force on 1st January 2015, in order to reduce greenhouse gas emissions. It aims to reduce the amount of HFC (hydrofluorocarbon) refrigerant used in cooling and heating systems by 79% by 2030.

Although R32 is part of the HFC refrigerants group, its properties mean it is a more environmentally friendly and efficient refrigerant.

These properties mean that:

- It is easier to recover and recycle, as it is a pure refrigerant (without mixture).
- It is more environmentally friendly as it has a lower PCA than other refrigerants.
- It has no impact on the ozone layer.
- With this refrigerant, the system needs 30% less refrigerant than with other systems.
- Its cost and associated tax are significantly lower than for other refrigerants.
- It works more efficiently, reducing electrical consumption and making it easier to attain high energy ratings in A+++ equipment.

Consumption of HFC compared to CO₂ equivalent tonnes



A step forward in respect for the environment

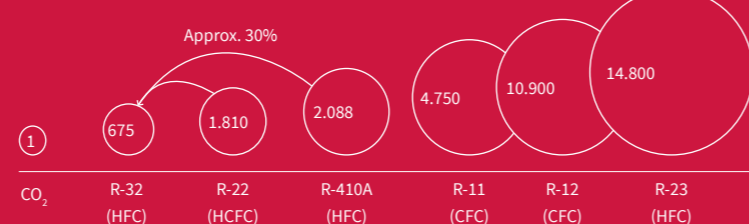

2 The new R32 range looks to protect the environment

At Hitachi we want to be part of this change and provide future systems which connect to the environment, creating harmony between people and their sustainable

lives, something we've been working on since 2013. Our goal is to complete the R32 range by 2025.



3 Discover the latest Hitachi devices with R32

Our indoor climate range includes different styles of indoor units between 2 to 7 kW. Attention is always paid to energy efficiency, appealing aesthetics and quiet operation.

4 Frost Wash

This unique patented technology allows the unit to self clean the heat exchanger by freezing it and then melting the ice to wash away the dust and allergens.



https://youtu.be/qNH_YXhWM2o

5 Compatible with Hi-Kumo App

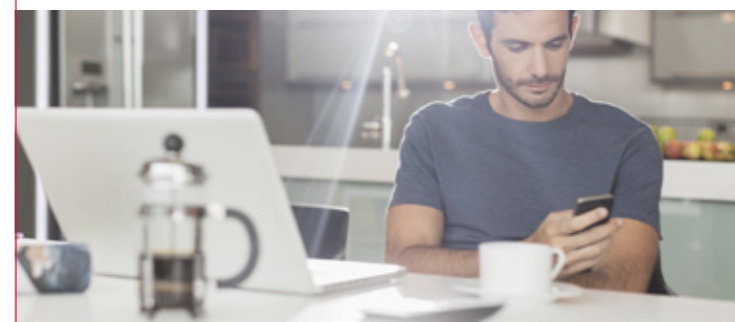

The whole indoor climate range is compatible with the Hi-Kumo app. Your smartphone becomes a remote control and you can switch your unit on and off, set the temperature and alter the schedule from anywhere in the world.

6 ECO - Human sensor

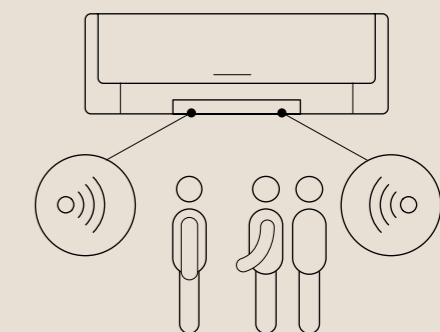

The Human sensor detects movement in the room and automatically adjusts the operation of the unit to save unnecessary operating costs.

Summit

High-efficiency and simplicity



Compatible with Hi-Kumo Wi-Fi control

This control can be used to turn the unit on or off, increase or decrease the temperature, or programme the system from anywhere in the world. All you need is a mobile phone, internet connection and Wi-Fi equipment (optional) to connect to the air unit.

Full use of space

It can be installed discreetly thanks to its compact size. For instance, above a door it is only 780 mm long. (Fig. 1)

Ultraquiet operation

Its low noise level of just 19dB means you will enjoy a comfortable environment without even noticing that the indoor unit is on.
*check model

Fig. 1

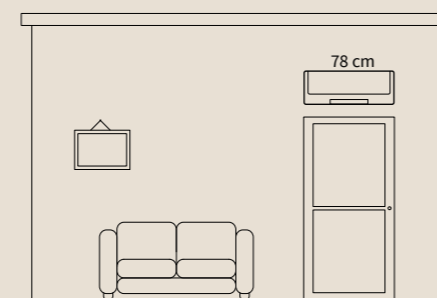

Indoor units

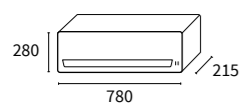

RAK-18PED
RAK-25PED
RAK-35PED
RAK-50PED

Outdoor units

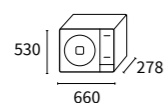

RAC-18WED
RAC-25WED
RAC-35WED

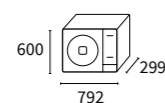

RAC-50WED

Summit

System			Summit 18	Summit 25	Summit 35	Summit 50
Capacity	Cooling (Min/Nom/Max)	kW	0.90-2.00-2.50	0.90-2.50-3.10	0.90-3.50-4.00	1.90-5.00-5.20
	Heating (Min/Nom/Max)	kW	0.90-2.50-3.20	0.90-3.40-4.40	0.90-4.20-5.00	2.20-6.00-7.30
Consumption	Cooling (Min/Nom/Max)	kW	0.25-0.58-1.01	0.25-0.70-1.29	0.25-1.09-1.46	0.50-1.56-2.10
	Heating (Min/Nom/Max)	kW	0.28-0.62-0.97	0.25-0.88-1.25	0.25-1.10-1.70	0.50-1.66-2.75
Electrical power			1 ~230V 50Hz	1 ~230V 50Hz	1 ~230V 50Hz	1 ~230V 50Hz
Indoor/outdoor wiring section (shielded)		mm2	1.5 x 3 + E	1.5 x 3 + E	1.5 x 3 + E	1.5 x 3 + E
EER			3.45	3.57	3.21	3.21
COP			4.03	3.86	3.82	3.61
SEER			6.1	6.10	6.10	6.10
SCOP			4.2	4.20	4.20	4.30
Energy rating (medium zone)	Cooling/Heating		A++/A+	A++/A+	A++/A+	A++/A+
Outside operating temperatures	Cooling (DB)	°C	-10 to 43	-10 to 43	-10 to 43	-10 to 43
	Heating (DB)	°C	-15 to 21	-15 to 21	-15 to 21	-15 to 21
Pipe diameter	Liquid-gas	inches	1/4-3/8	1/4-3/8	1/4-3/8	1/4-1/2
Remote control included			RAR-5F1	RAR-5F1	RAR-5F1	RAR-5F1
Indoor unit			RAK-18PED	RAK-25PED	RAK-35PED	RAK-50PED
Air flow (Very low - Low - Medium - High)	Cooling	m3/h	312-350-400-440	333-370-430-510	333-400-485-600	333-450-600-700
	Heating	m3/h	313-350-420-480	333-400-500-570	333-520-550-660	433-510-650-770
Sound pressure (Very low - Low - Medium - High)	Cooling	dB(A)	21-24-33-37	22-24-33-40	25-26-36-43	28-30-40-46
	Heating	dB(A)	19-22-33-38	20-23-34-41	26-27-36-44	25-30-38-47
Sound power		dB(A)	51	54	57	60
Dimensions (H x W x D)		mm	280x780x215	280x780x215	280x780x215	280x780x215
Weight		kg	7.5	7.5	7.5	8.0
Condensate pipe diameter (out)		mm	16	16	16	16
Outdoor unit			RAC-18WED	RAC-25WED	RAC-35WED	RAC-50WED
Air flow	Cooling	m3/h	1,860	1,860	1,860	2,160
	Heating	m3/h	1,620	1,620	1,620	2,160
Sound pressure	Cooling	dB(A)	45	47	48	50
	Heating	dB(A)	46	48	49	50
Sound power		dB(A)	59	61	62	64
Maximum pipe length		m	20	20	20	20
Maximum height difference		m	10	10	10	10
Compressor			Rotary	Rotary	Rotary	Rotary
Refrigerant			R32	R32	R32	R32
Refrigerant charge (length without additional charge)		kg (m)	0.53 (20)	0.53 (20)	0.70 (20)	0.93 (20)
Additional refrigerant charge		g/m	not required	not required	not required	not required
Dimensions (H x W x D)		mm	530x660x278	530x660x278	530x660x278	600x792x299
Weight		kg	23.0	23.0	24.5	39.5

Compatible controls and accessories:



Wireless control
RAR-5F1
Included



Simplified wired control
SPX-RCDB



Programmable wired control
SPX-WKT3

Others:

- SPX-DST1 distributor
- H-Link PSC-6RAD box
- SPX-WFG01 Wi-Fi adapter

Performance

Compact size and high performance

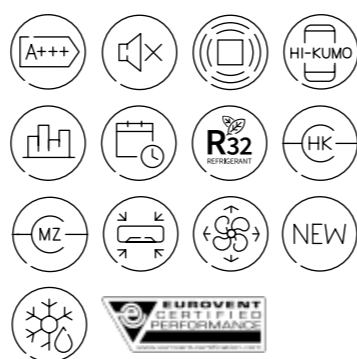

Enhanced comfort with 4-Way Swing

The vertical and horizontal movement of the slats ensures a more uniform distribution of air for greater comfort in the room. (Fig. 1)

Presence sensor

These units are fitted with a presence sensor to ensure optimal consumption in accordance with the number of people in a room. This sensor gradually decreases energy consumption as the room empties, and increases it as human movement is detected. (Fig. 2)

Compatible with Hi-Kumo Wi-Fi control

This control can be used to turn the unit on or off, increase or decrease the temperature, or programme the system from anywhere in the world. All you need is a mobile phone, internet connection and Wi-Fi equipment (optional) to connect to the air unit.

Full use of space

It can be installed discreetly thanks to its compact size. For instance, above a door it is only 780 mm long. (Fig. 3)

Ultraquiet operation

Its low noise level of just 19dB means you will enjoy a comfortable environment without even noticing that the indoor unit is on. *check model

First-class energy efficiency

Lower energy consumption thanks to its A+++ energy rating. Use your air conditioning while barely noticing its effect on your electricity bill. *check model

ADJUST YOUR SETPOINT TEMPERATURE:
1°C = 7% ENERGY SAVING

Fig. 1

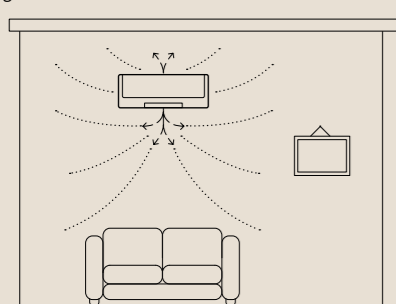

Fig. 2

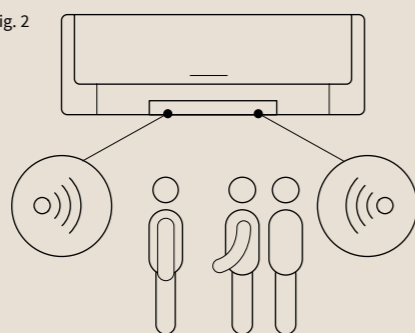
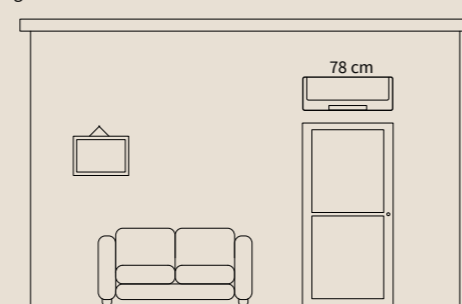
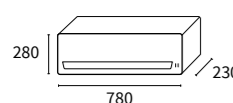

Fig. 3



Indoor units

Outdoor units



RAK-18RPE
RAK-25RPE
RAK-35RPE
RAK-42RPE
RAK-50RPE

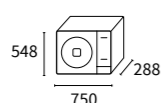

RAC-18WPE
RAC-25WPE
RAC-35WPE

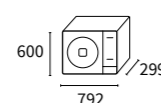

RAC-42WPE
RAC-50WPE

Performance

System			Performance 18	Performance 25	Performance 35	Performance 42	Performance 50
Capacity	Cooling (Min/Nom/Max)	kW	0.90-2.00-2.50	0.90-2.50-3.10	0.90-3.50-4.00	1.70-4.20-5.00	1.90-5.00-5.20
	Heating (Min/Nom/Max)	kW	0.90-2.50-3.20	0.90-3.40-4.40	0.90-4.20-5.00	1.70-5.40-6.00	2.20-6.00-7.30
Consumption	Cooling (Min/Nom/Max)	kW	0.25-0.42-1.01	0.25-0.55-1.29	0.25-0.94-1.46	0.30-1.12-1.70	0.30-1.47-2.10
	Heating (Min/Nom/Max)	kW	0.25-0.52-0.97	0.25-0.73-1.50	0.25-1.00-1.70	0.50-1.32-2.10	0.50-1.56-2.75
Electrical power			1 ~230V 50Hz	1 ~230V 50Hz	1 ~230V 50Hz	1 ~230V 50Hz	1 ~230V 50Hz
Indoor/outdoor wiring section (shielded)		mm2	1.5 x 3 + E	1.5 x 3 + E	1.5 x 3 + E	2.5 x 3 + E	2.5 x 3 + E
EER			4.77	4.55	3.72	3.75	3.40
COP			4.82	4.64	4.20	4.10	3.85
SEER			8.50	8.50	7.80	7.50	7.35
SCOP			4.90	4.90	4.90	4.60	4.60
Energy rating (medium zone)	Cooling/Heating		A+++/A++	A+++/A++	A++/A++	A++/A++	A++/A++
Outside operating temperatures	Cooling (DB)	°C	-10 to 43	-10 to 43	-10 to 43	-10 to 43	-10 to 43
	Heating (DB)	°C	-15 to 21	-15 to 21	-15 to 21	-15 to 21	-15 to 21
Pipe diameter	Liquid-gas	inches	1/4-3/8	1/4-3/8	1/4-3/8	1/4-1/2	1/4-1/2
Remote control included			RAR-6NE1	RAR-6NE1	RAR-6NE1	RAR-6NE1	RAR-6NE1
Indoor unit			RAK-18RPE	RAK-25RPE	RAK-35RPE	RAK-42RPE	RAK-50RPE
Air flow (Very low - Low - Medium - High)	Cooling	m3/h	312-350-400-440	333-370-430-510	353-420-485-680	353-410-540-720	353-410-540-750
	Heating	m3/h	312-350-420-480	333-400-500-570	363-480-570-780	380-500-610-800	380-500-610-820
Sound pressure (Very low - Low - Medium - High)	Cooling	dB(A)	21-24-33-37	22-24-33-40	25-26-36-43	25-28-39-46	25-28-39-46
	Heating	dB(A)	19-22-33-38	20-23-34-41	26-27-36-44	27-31-39-46	27-31-39-46
Sound power		dB(A)	51	54	57	60	60
Dimensions (H x W x D)		mm	280x780x230	280x780x230	280x780x230	280x780x230	280x780x230
Weight		kg	8.5	8.5	8.5	8.5	8.5
Condensate pipe diameter (out)		mm	16	16	16	16	16
Outdoor unit			RAC-18WPE	RAC-25WPE	RAC-35WPE	RAC-42WPE	RAC-50WPE
Air flow	Cooling	m3/h	1,860	1,860	1,920	2,160	2,160
	Heating	m3/h	1,620	1,620	1,620	2,160	2,160
Sound pressure	Cooling	dB(A)	44	46	48	49	49
	Heating	dB(A)	45	47	49	50	50
Sound power		dB(A)	58	60	61	63	63
Maximum pipe length		m	20	20	20	20	20
Maximum height difference		m	10	10	10	10	10
Compressor			Rotary	Rotary	Rotary	Rotary	Rotary
Refrigerant			R32	R32	R32	R32	R32
Refrigerant charge (length without additional charge)		kg (m)	0.87 (20)	0.87 (20)	0.87 (20)	1.05 (20)	1.05 (20)
Additional refrigerant charge		g/m	not required	not required	not required	not required	not required
Dimensions (H x W x D)		mm	548x750x288	548x750x288	548x750x288	600x792x299	600x792x299
Weight		kg	32.5	32.5	32.5	39.0	39.0

Compatible controls and accessories:

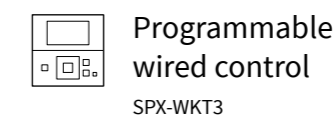

Others:
- SPX-DST1 distributor
- H-Link PSC-6RAD box
- SPX-WFG01 Wi-Fi adapter

Light Commercial Wall-Mounted

High performance and built-in presence sensor

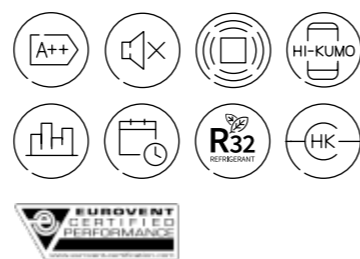

Enhanced comfort with 4-Way Swing

Air distribution is more uniform thanks to the vertical and horizontal movement of the slats, thus improving comfort in the room. (Fig. 1)

First-class energy efficiency

Lower energy consumption thanks to its A++ energy rating.* Use your air conditioning while barely noticing its effect on your electricity bill. *check model

Presence sensor

Air conditioning without any unnecessary consumption thanks to the presence sensor, which decreases the system's energy consumption gradually when the room empties, and puts it back into operation when it detects human movement. (Fig. 2)

Enhanced comfort

This system allows us to choose where to measure the setpoint temperature (in the control, in the return, or the average of both values). This feature ensures enhanced comfort in the room.

Flexible installation

There is up to 30 m of cooling pipe between the indoor and outdoor units, meaning the system can be installed almost anywhere in the building. Furthermore, the height difference between them can reach up to 20 m.

Compatible with Hi-Kumo Wi-Fi control

This control can be used to turn the unit on or off, increase or decrease the temperature, or programme the system from anywhere in the world. All you need is a mobile phone, internet connection and Wi-Fi equipment (optional) to connect to the air unit.

Compact indoor unit

The indoor unit is only 900 mm wide, which means it can be installed virtually anywhere without interfering with other elements. Other systems on the market are around 1,000 mm wide, and some of them even exceed this width.

Fig. 1

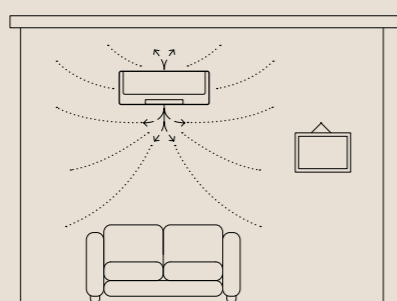
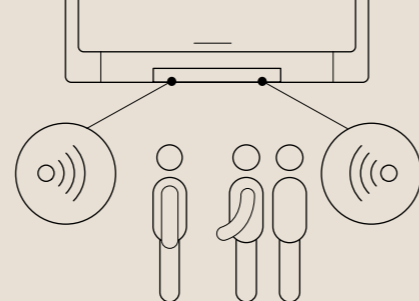
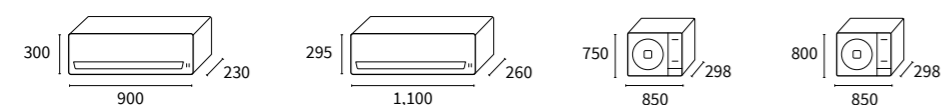

Fig. 2



Indoor units



RAK-50RPE1
RAK-60RPE

RAK-70RPD

RAC-50NPE
RAC-60NPE

RAC-70NPD

Outdoor units

Light Commercial Wall-mounted

System			Light commercial 50	Light commercial 60	Light commercial 70
Capacity	Cooling (Min/Nom/Max)	kW	1.20-5.00-5.80	1.20-6.00-6.50	1.50-7.00-8.00
	Heating (Min/Nom/Max)	kW	1.20-6.00-6.80	1.20-7.00-8.00	1.50-8.00-8.50
Consumption	Cooling (Min/Nom/Max)	kW	0.30-1.42-2.50	0.30-1.71-2.65	0.50-2.00-2.70
	Heating (Min/Nom/Max)	kW	0.30-1.50-2.65	0.30-1.84-2.65	0.50-2.10-2.80
Electrical power			1 ~230V 50Hz	1 ~230V 50Hz	1 ~230V 50Hz
Indoor/outdoor wiring section (shielded)		mm2	1.5 x 3 + E	1.5 x 3 + E	1.5 x 3 + E
EER			3.52	3.51	3.50
COP			4.00	3.80	3.81
SEER			7.30	6.50	7.00
SCOP			4.60	4.20	4.60
Energy rating (medium zone)	Cooling/Heating		A+/A++	A+/A+	A+/A++
Outside operating temperatures	Cooling (DB)	°C	-15 to 46	-15 to 46	-15 to 46
	Heating (DB)	°C	-15 to 24	-15 to 24	-15 to 24
Pipe diameter	Liquid-gas	inches	1/4-1/2	1/4-1/2	1/4-5/8
Remote control included			not included	not included	not included
Indoor unit			RAK-50RPE1	RAK-60RPE	RAK-70RPD
Air flow (Very low - Low - Medium - High)	Cooling	m3/h	310-410-570-720	480-540-690-930	510-630-870-1,020
	Heating	m3/h	350-460-640-800	480-510-720-1050	510-630-870-1,080
Sound pressure (Very low - Low - Medium - High)	Cooling	dB(A)	26-33-39-47	30-33-42-48	30-36-42-47
	Heating	dB(A)	26-33-39-47	33-34-42-49	30-36-42-47
Sound power		dB(A)	60	60	60
Dimensions (H x W x D)		mm	300x900x230	300x900x230	300x1100x260
Weight		kg	11.5	11.5	15.0
Condensate pipe diameter (out)		mm	16	16	16
Outdoor unit			RAC-50NPE	RAC-60NPE	RAC-70NPD
Air flow	Cooling	m3/h	2,160	2,160	2,700
	Heating	m3/h	2,160	2,160	2,700
Sound pressure	Cooling	dB(A)	50	50	52
	Heating	dB(A)	53	53	54
Sound power		dB(A)	60/65	60/65	60/67
Maximum pipe length		m	30	30	30
Maximum height difference		m	20	20	20
Compressor			Rotary	Rotary	Rotary
Refrigerant			R32	R32	R32
Refrigerant charge (length without additional charge)		kg (m)	1.5 (30)	1.5 (30)	1.6 (30)
Additional refrigerant charge		g/m	not required	not required	not required
Dimensions (H x W x D)		mm	750x850x298	750x850x298	800x850x298
Weight		kg	50.0	50.0	52.0

Compatible controls and accessories:

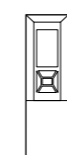

Wireless Eco Control
SPX-RCKA2



Simplified wired control
SPX-RCDB

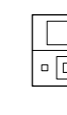

Programmable wired control
SPX-WKT3

Others:
- SPX-DST1 distributor
- H-Link PSC-6RAD box
- SPX-WFG01 Wi-Fi adapter

Shirokuma

Highest performance with the best options

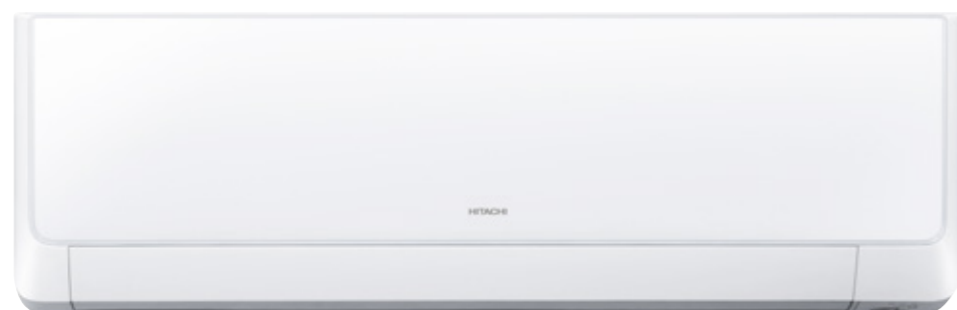
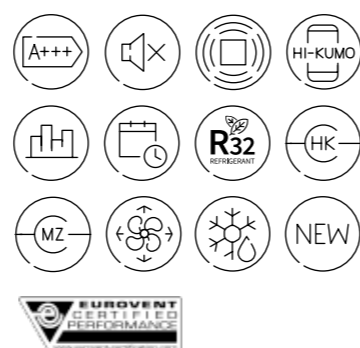

Presence sensor

Air conditioning without any unnecessary consumption thanks to the presence sensor, which decreases the system's energy consumption gradually when the room empties, and puts it back into operation when it detects human movement. (Fig. 1)

Enhanced comfort with 4-Way Swing

Air distribution is more uniform thanks to the vertical and horizontal movement of the slats, thus improving comfort in the room. (Fig. 2)

Constant power

The system guarantees heating operation without any loss of heat with an outside temperature of up to -15 °C. Optimal heating power when you need it most. (Fig. 3)

First-class energy efficiency

Lower energy consumption thanks to its A+++ energy rating.* Use your air conditioning while barely noticing its effect on your electricity bill.* check model

ADJUST YOUR SETPOINT TEMPERATURE:
1°C = 7% ENERGY SAVING

High-quality components

The indoor unit components, including the filter, are made of stainless steel, bringing increased durability and improved air quality.

Compatible with Hi-Kumo Wi-Fi control

This control can be used to turn the unit on or off, increase or decrease the temperature, or programme the system from anywhere in the world. All you need is a mobile phone, internet connection and Wi-Fi equipment (optional) to connect to the air unit.

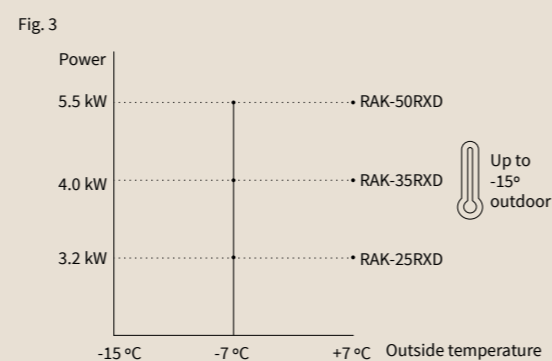
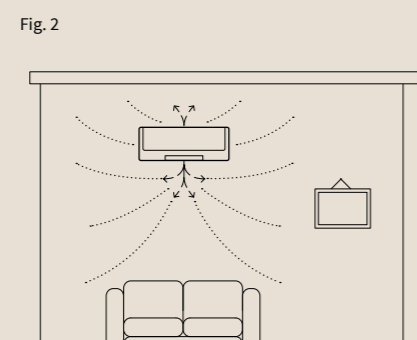
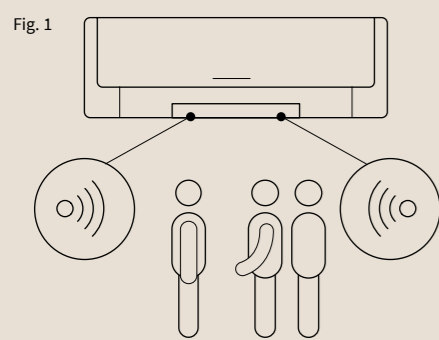

Indoor units

Outdoor units

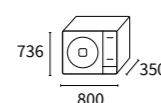
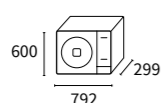
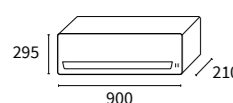

RAK-25RXE
RAK-35RXE
RAK-50RXE

RAC-25WXE
RAC-35WXE

RAC-50WXE

Shirokuma

System			Shirokuma 25	Shirokuma 35	Shirokuma 50
Capacity	Cooling (Min/Nom/Max)	kW	0.90-2.50-3.10	0.90-3.50-4.00	1.90-5.00-5.20
	Heating (Min/Nom/Max)	kW	0.90-3.20-4.20	0.90-4.00-4.80	2.20-5.80-7.00
Consumption	Cooling (Min/Nom/Max)	kW	0.25-0.48-1.00	0.25-0.81-1.40	0.50-1.40-2.10
	Heating (Min/Nom/Max)	kW	0.25-0.59-1.20	0.25-0.80-1.60	0.50-1.42-2.70
Electrical power			1 ~230V 50Hz	1 ~230V 50Hz	1 ~230V 50Hz
Indoor/outdoor wiring section (shielded)		mm2	1.5 x 3 + E	1.5 x 3 + E	2.5 x 3 + E
EER			5.20	4.30	3.58
COP			5.40	5.00	4.10
SEER			8.50	8.70	7.50
SCOP			5.20	5.20	4.70
Energy rating (medium zone)	Cooling/Heating		A+++/A+++	A+++/A+++	A++/A++
Outside operating temperatures	Cooling (DB)	°C	-10 to 43	-10 to 43	-10 to 43
	Heating (DB)	°C	-20 to 21	-20 to 21	-20 to 21
Pipe diameter	Liquid-gas	inches	1/4-3/8	1/4-3/8	1/4-1/2
Remote control included			RAR-6NE1	RAR-6NE1	RAR-6NE1
Indoor unit			RAK-25RXE	RAK-35RXE	RAK-50RXE
Air flow (Very low - Low - Medium - High)	Cooling	m3/h	300-330-510-600	320-340-520-660	350-400-580-720
	Heating	m3/h	290-370-560-680	310-380-570-720	350-420-620-800
Sound pressure (Very low - Low - Medium - High)	Cooling	dB(A)	20-27-35-43	22-29-37-45	25-31-39-47
	Heating	dB(A)	20-28-36-43	22-30-37-45	25-31-39-48
Sound power		dB(A)	58	60	60
Dimensions (H x W x D)		mm	295x900x210	295x900x210	295x900x210
Weight		kg	11	11	11
Condensate pipe diameter (out)		mm	16	16	16
Outdoor unit			RAC-25WXE	RAC-35WXE	RAC-50WXE
Air flow	Cooling	m3/h	1,860	1,920	2,160
	Heating	m3/h	1,620	1,620	2,160
Sound pressure	Cooling	dB(A)	47	48	51
	Heating	dB(A)	48	50	51
Sound power		dB(A)	61	62	65
Maximum pipe length		m	20	20	30
Maximum height difference		m	10	10	10
Compressor			Rotary	Rotary	Rotary
Refrigerant			R32	R32	R32
Refrigerant charge (length without additional charge)		kg (m)	0.98	0.98	1.30
Additional refrigerant charge		g/m	not required	not required	not required
Dimensions (H x W x D)		mm	600x792x299	600x792x299	736x800x350
Weight		kg	37.5	37.5	51.5

Compatible controls and accessories:

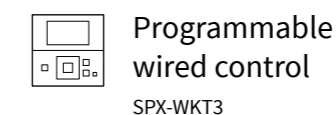

Others:
- SPX-DST1 distributor
- H-Link PSC-6RAD box
- SPX-WFG01 Wi-Fi adapter

S-Premium

An air conditioner for life, with stainless steel interior and automated self-cleaning.

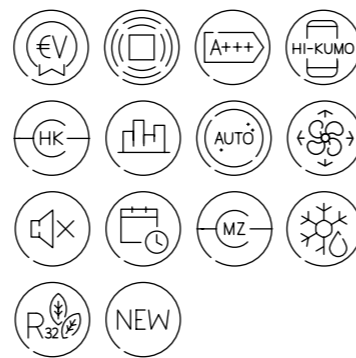

Clean, more efficient air conditioning

The interiors of the premium indoor unit series are made from stainless steel reducing the accumulation of dust by 51% compared to plastic models. The stainless steel air filter is self cleaned automatically on a regular basis (Fig. 1). The new Frost wash function automatically cleans the heat exchanger ensuring the purest air possible for your rooms.

Energy class A+++*

High efficiency for optimal performance and significant running cost savings.

*2.5 and 3.5kW units



Excellent Design

Premium series wall mounts are available in silver and matt white. The simple design and classy finish ensures the unit blends in perfectly to your premises.



Fig. 1 Hitachi "Self-cleaning" robot

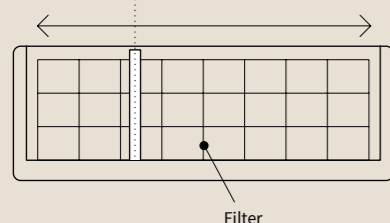

Increased comfort through Human sensor

Air conditioning without any unnecessary consumption thanks to the presence sensor, which decreases the system's energy consumption gradually when the room empties, and puts it back into operation when it detects human movement.

Everything at a glance

The LCD display is integrated into the front of the device, which on request, can display information about the operation such as temperature setting and mode.

Indoor units

Outdoor units

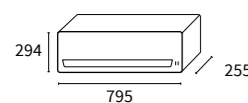

RAK-25PSE(W/S)
RAK-35PSE(W/S)
RAK-50PSE(W/S)

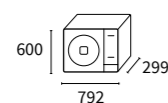

RAC-25WSE
RAC-35WSE

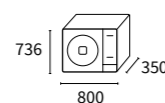

RAC-50WSE

S-Premium

System			Premium 25	Premium 35	Premium 50
Capacity	Cooling (Min/Nom/Max)	kW	0.50-2.50-3.40	0.50-3.50-4.10	1.90-5.00-5.20
	Heating (Min/Nom/Max)	kW	0.60-3.20-5.80	0.60-4.00-6.60	2.20-6.00-7.00
Consumption	Cooling (Min/Nom/Max)	kW	0.30-0.49-0.92	0.35-0.78-1.35	0.40-1.39-1.82
	Heating (Min/Nom/Max)	kW	0.44-0.62-1.50	0.50-0.80-2.00	0.60-1.62-2.65
Electrical power			1 ~230V 50Hz	1 ~230V 50Hz	1 ~230V 50Hz
Indoor/outdoor wiring section (shielded)		mm ²	1.5 × 3 + E	1.5 × 3 + E	1.5 × 3 + E
EER			5.10	4.50	3.60
COP			5.15	5.00	3.70
SEER			9.00	9.00	7.50
SCOP			5.10	5.10	4.70
Energy rating (Average climate)	Cooling/Heating		A++/A++	A++/A++	A++/A++
Outside operating temperatures	Cooling (DB)	°C	-10 to 43	-10 to 43	-10 to 43
	Heating (DB)	°C	-20 to 24	-20 to 24	-20 to 24
Pipe diameter	Liquid-Gas	inches	1/4-3/8	1/4-3/8	1/4-1/2
Remote control included			RAR-6NE2	RAR-6NE2	RAR-6NE2
Indoor unit			RAK-25PSE(W/S)	RAK-35PSE(W/S)	RAK-50PSE(W/S)
Air flow (Very low - Low - Medium - High)	Cooling	m ³ /h	270-320-420-510	270-340-440-540	300-400-490-590
	Heating	m ³ /h	310-400-490-600	310-430-520-630	330-450-560-680
Sound pressure (Very low - Low - Medium - High)	Cooling	dB(A)	22-28-34-41	22-29-36-43	25-31-38-46
	Heating	dB(A)	22-28-34-42	22-29-36-44	25-31-38-48
Sound power		dB(A)	55	57	60
Dimensions (H × W × D)		mm	294 × 795 × 250	294 × 795 × 250	294 × 795 × 250
Weight		kg	11.0	11.0	11.0
Condensate pipe diameter (out)		mm	16	16	16
Outdoor unit			RAC-25WSE	RAC-35WSE	RAC-50WSE
Air flow	Cooling	m ³ /h	1,860	1,920	2,160
	Heating	m ³ /h	1,620	1,620	2,160
Sound pressure	Cooling	dB(A)	47	48	51
	Heating	dB(A)	48	50	51
Sound power		dB(A)	61	62	65
Minimum pipe length		m	3	3	3
Maximum pipe length		m	20	20	30
Maximum height difference		m	10	10	10
Compressor			Rotary	Rotary	2 Cylinder Rotary
Refrigerant			R32	R32	R32
Refrigerant charge (Length without additional charge)		kg (m)	0.98 (20)	0.98 (20)	1.24 (30)
Additional refrigerant charge		g/m	-	-	-
Dimensions (H × W × D)		mm	600 × 792 × 299	600 × 792 × 299	736 × 800 × 350
Weight		kg	37.0	37.0	51.0

Compatible controls and accessories:

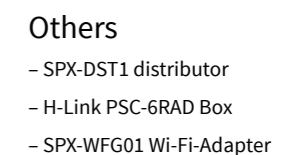
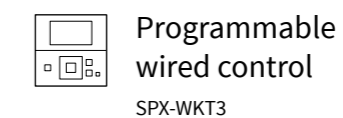
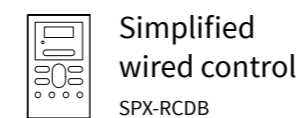

Light Commercial Cassette

High performance control options

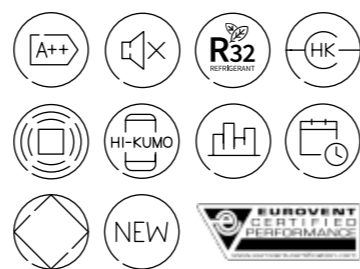

Condensate pump included

The LC cassette is fitted with its own pump to automatically remove condensate liquid. No need to purchase additionally. (Fig. 1)

First-class energy efficiency

Lower energy consumption thanks to its A++ energy rating.* Use your air conditioning while barely noticing its effect on your electricity bill. *check model

Enhanced comfort

This system allows us to choose where to measure the setpoint temperature (in the control, in the return, or the average of both values). This feature ensures enhanced comfort in the room.

Flexible installation

There is up to 30 m of cooling pipe between the indoor and outdoor units, meaning the system can be installed almost anywhere in the building. Furthermore, the height difference between them can reach up to 20 m.

Compatible with Hi-Kumo Wi-Fi control

This control can be used to turn the unit on or off, increase or decrease the temperature, or programme the system from anywhere in the world. All you need is a mobile phone, internet connection and Wi-Fi equipment (optional) to connect to the air unit.

Individual louvre control

Each louvre of the cassette can be individually controlled for a comfortable air flow and adaptability to all room configurations. (Fig. 2)

Fig. 1

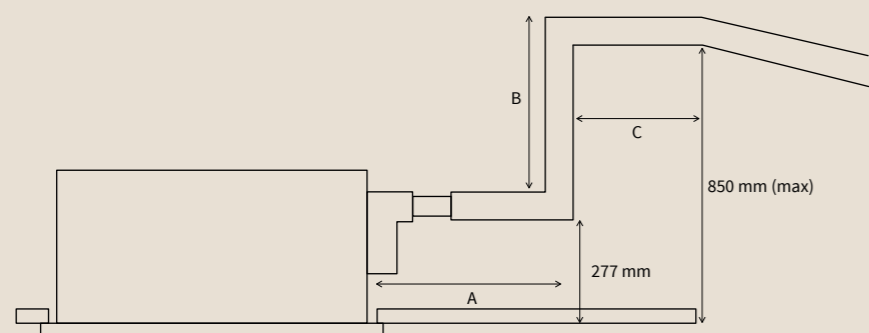
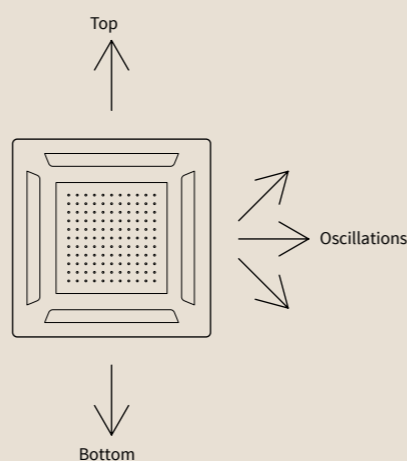
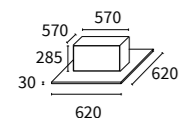

Fig. 2



Indoor units



RAI-25RPE
RAI-35RPE
RAI-50RPE
RAI-60RPE

Outdoor units

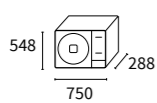

RAC-25NPE
RAC-35NPE

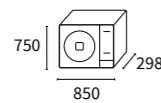

RAC-50NPE
RAC-60NPE

Light Commercial Cassette

System			RAI 25 RPE	RAI 35 RPE	RAI 50 RPE	RAI 60 RPE
Capacity	Cooling (Min/Nom/Max)	kW	0.90-2.50-3.00	0.90-3.50-4.00	1.20-5.00-5.80	1.20-6.00-6.50
	Heating (Min/Nom/Max)	kW	0.90-3.50-5.00	0.90-4.80-6.60	1.20-6.00-6.80	1.20-7.00-8.00
Consumption	Cooling (Min/Nom/Max)	kW	0.25-0.60-1.29	0.25-0.88-1.46	0.30-1.42-2.50	0.30-1.71-2.60
	Heating (Min/Nom/Max)	kW	0.25-0.88-1.50	0.25-1.23-1.92	0.30-1.57-2.65	0.30-1.84-2.65
Electrical power			1 ~230V 50Hz	1 ~230V 50Hz	1 ~230V 50Hz	1 ~230V 50Hz
Indoor/outdoor wiring section (shielded)		mm2	1.5 x 3 + E	1.5 x 3 + E	1.5 x 3 + E	1.5 x 3 + E
EER			4.20	4.00	3.52	3.51
COP			4.00	3.90	3.82	3.80
SEER			6.20	6.50	6.20	6.20
SCOP			4.30	4.30	4.40	4.40
Energy rating (medium zone)	Cooling/Heating		A++/A+	A++/A+	A++/A+	A++/A+
	Outside operating temperatures					
Pipe diameter	Cooling (DB)	°C	-10 to 46	-10 to 46	-15 to 46	-15 to 46
	Heating (DB)	°C	-15 to 24	-15 to 24	-15 to 24	-15 to 24
	Liquid-gas	inches	1/4-3/8	1/4-3/8	1/4-1/2	1/4-1/2
Indoor unit			RAI-25RPE	RAI-35RPE	RAI-50RPE	RAI-60RPE
Air flow (Very low - Low - Medium - High)	Cooling	m3/h	360-505-590-660	360-505-590-660	390-540-630-720	390-540-630-720
	Heating	m3/h	444-540-630-720	444-540-630-720	450-600-690-780	450-600-690-780
Sound pressure (Very low - Low - Medium - High)	Cooling	dB(A)	27-31-35-38	27-33-37-40	29-35-39-43	29-35-39-43
	Heating	dB(A)	28-32-36-39	28-34-38-41	30-36-40-44	30-36-40-44
Sound power		dB(A)	54	56	56	56
Cassette dimensions (H x W x D)		mm	285x570x570	285x570x570	285x570x570	285x570x570
Cassette weight		kg	17	17	17.0	17.0
Panel dimensions (H x W x D)		mm	30x620x620	30x620x620	30x620x620	30x620x620
Panel weight		kg	2.8	2.8	2.8	2.8
Condensate pipe diameter (out)		mm	32	32	32	32
Condensate pump			Included	Included	Included	Included
Outdoor unit			RAC-25NPE	RAC-35NPE	RAC-50NPE	RAC-60NPE
Air flow	Cooling	m3/h	1920	1920	2,160	2,160
	Heating	m3/h	1620	1620	2,160	2,160
Sound pressure	Cooling	dB(A)	48	48	50	50
	Heating	dB(A)	49	49	53	53
Sound power		dB(A)	61	61	56/65	56/65
Maximum pipe length		m	20	20	30	30
Maximum height difference		m	10	10	20	20
Compressor			Rotary	Rotary	Rotary	Rotary
Refrigerant			R32	R32	R32	R32
Refrigerant charge (length without additional charge)		kg (m)	0.9 (20)	0.9 (20)	1.5 (30)	1.5 (30)
Additional refrigerant charge		g/m	not required	not required	not required	not required
Dimensions (H x W x D)		mm	548x750x288	548x750x288	750x850x298	750x850x298
Weight		kg	32.5	32.5	50.0	50.0

Compatible controls and accessories:

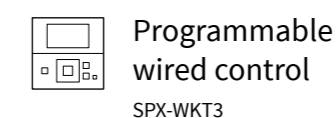

Others:
- SPX-DST1 distributor
- H-Link PSC-6RAD box
- SPX-WFG01 Wi-Fi adapter

Light Commercial Ducts

Operation down to -15°C

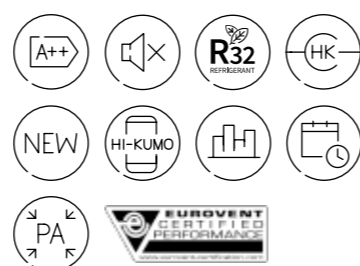

Condensate pump included

The LC duct is fitted with its own pump to automatically remove condensate liquid. No need to purchase additionally. (Fig. 1)

First-class energy efficiency

Lower energy consumption thanks to its A++ energy rating.* Use your air conditioning while barely noticing its effect on your electricity bill. *check model

High static pressure

Since the unit has 150Pa pressure, the ducts unit can be installed wherever they cause least disturbance. The user therefore does not have to worry about not getting enough air to the room furthest away.

Flexible installation

There is up to 30 m of cooling pipe between the indoor and outdoor units, meaning the system can be installed almost anywhere in the building. Furthermore, the height difference between them can reach up to 20 m.

Compatible with Hi-Kumo Wi-Fi control

This control can be used to turn the unit on or off, increase or decrease the temperature, or

programme the system from anywhere in the world. All you need is a mobile phone, internet connection and Wi-Fi equipment (optional) to connect to the air unit.

Enhanced comfort

This system allows us to choose where to measure the setpoint temperature (in the control, in the return, or the average of both values). This feature ensures enhanced comfort in the room.

Fig. 1

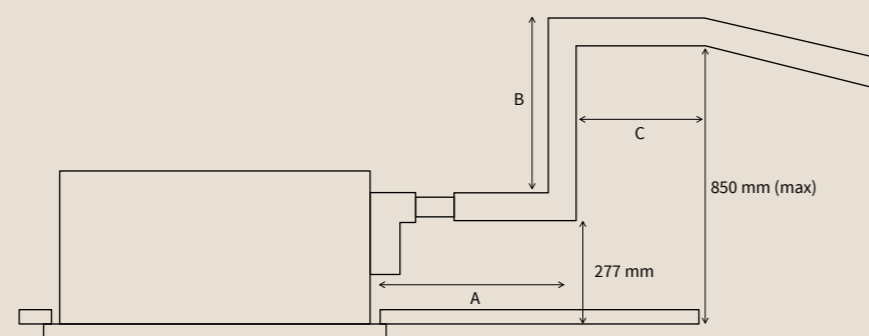

Indoor units

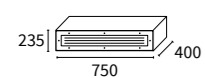

RAD-25RPE
RAD-35RPE

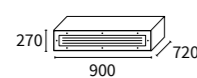

RAD-50RPE
RAD-60RPE
RAD-70PPD

Outdoor units

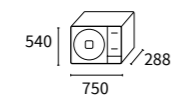

RAC-25NPE
RAC-35NPE

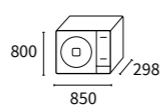

RAC-50NPE
RAC-60NPE
RAC-70NPD

Light Commercial Ducts

System			RAD 25 RPE	RAD 35 RPE	RAD 50RPE	RAD 60RPE	RAD 70PPD
Capacity	Cooling (Min/Nom/Max)	kW	0.90-2.50-3.00	0.90-3.50-4.00	1.20-5.00-5.80	1.20-6.00-6.50	1.50-7.00-8.00
	Heating (Min/Nom/Max)	kW	0.90-3.50-5.50	0.90-4.80-6.60	1.20-6.00-6.80	1.20-7.00-8.00	1.50-8.00-8.50
Consumption	Cooling (Min/Nom/Max)	kW	0.25-0.60-1.29	0.25-0.95-1.46	0.30-1.42-2.50	0.30-1.71-2.60	0.50-2.11-2.70
	Heating (Min/Nom/Max)	kW	0.25-0.88-1.50	0.25-1.26-1.92	0.30-1.57-2.65	0.30-1.84-2.65	0.50-2.20-2.80
Electrical power			1 ~230V 50Hz	1 ~230V 50Hz	1 ~230V 50Hz	1 ~230V 50Hz	1 ~230V 50Hz
Indoor/outdoor wiring section (shielded)		mm2	1.5 x 3 + E	1.5 x 3 + E	1.5 x 3 + E	1.5 x 3 + E	1.5 x 3 + E
EER			4.20	3.70	3.52	3.51	3.32
COP			4.00	3.81	3.82	3.80	3.64
SEER			6.20	6.50	6.20	6.20	6.10
SCOP			4.30	4.30	4.00	4.00	4.00
Energy rating (medium zone)	Cooling/Heating		A++/A+	A++/A+	A++/A+	A++/A+	A++/A+
Outside operating temperatures	Cooling (DB)	°C	-10 to 46	-10 to 46	-15 to 46	-15 to 46	-15 to 46
	Heating (DB)	°C	-15 to 24	-15 to 24	-15 to 24	-15 to 24	-15 to 24
Pipe diameter	Liquid-gas	inches	1/4-3/8	1/4-3/8	1/4-1/2	1/4-1/2	1/4-5/8
Indoor unit			RAD-25RPE	RAD-35RPE	RAD-50RPE	RAD-60RPE	RAD-70PPD
Air flow (Very low - Low - Medium - High)	Cooling	m3/h	330-390-450-510	330-390-450-510	350-540-800-1,140	350-540-800-1,140	350-540-800-1,140
	Heating	m3/h	330-390-450-510	330-390-450-510	350-540-800-1,140	350-540-800-1,140	350-540-800-1,140
Sound pressure (Very low - Low - Medium - High)	Cooling	dB(A)	30-33-37-41	30-33-37-41	29-32-35-39	29-32-35-39	29-32-35-39
	Heating	dB(A)	30-34-38-42	30-34-38-42	29-32-35-40	29-32-35-40	29-32-35-40
Sound power		dB(A)	57	57	53	53	53
Dimensions (H x W x D)		mm	235x750x400	235x750x400	270x900x720	270x900x720	270x900x720
Weight		kg	16.0	16.0	35.0	35.0	35.0
Condensate pipe diameter (out)		mm	16	16	32	32	32
Condensate pump			Included	Included	Included	Included	Included
Outdoor unit			RAC-25NPE	RAC-35NPE	RAC-50NPE	RAC-60NPE	RAC-70NPD
Air flow	Cooling	m3/h	1,920	1,920	2,160	2,160	2,700
	Heating	m3/h	1,620	1,620	2,160	2,160	2,700
Sound pressure	Cooling	dB(A)	48	48	50	50	50
	Heating	dB(A)	49	49	53	53	53
Sound power		dB(A)	61	61	53/65	53/65	53/65
Maximum pipe length		m	20	20	30	30	30
Maximum height difference		m	10	10	20	20	20
Compressor			Rotary	Rotary	Rotary	Rotary	Rotary
Refrigerant			R32	R32	R32	R32	R32
Refrigerant charge (length without additional charge)		kg (m)	0.9 (20)	0.9 (20)	1.5 (30)	1.5 (30)	1.6 (30)
Additional refrigerant charge		g/m	not required	not required	not required	not required	not required
Dimensions (H x W x D)		mm	548x750x288	548x750x288	750x850x298	750x850x298	800x850x298
Weight		kg	32.5	32.5	50.0	50.0	52.0

Compatible controls and accessories:

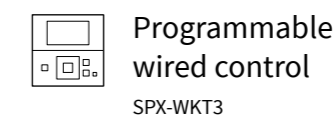
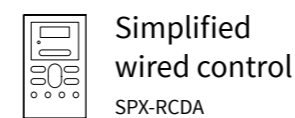

Others:
- SPX-DST1 distributor
- H-Link PSC-6RAD box
- SPX-WFG01 Wi-Fi adapter

Shirokuma Console

A unit with discreet design and high performance

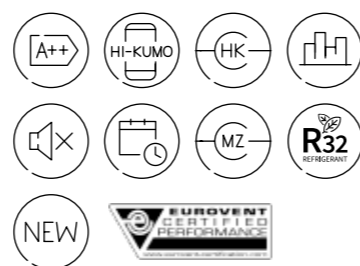

Extended air flow

The air can reach every corner of the room thanks to its greater **dynamic air flow**. The room is air conditioned (heated or cooled) at the touch of a button on the remote control.

(Fig. 1)

Flexibility with Multizone range

The Shirokuma console is compatible with all Multizone outdoor units, so more than one can be installed in multiple rooms with a single outdoor unit.

High performance

The system has A++ energy rating, ensuring high performance with low running costs.

Control options

The system is fitted with Eco Control as standard. It is also compatible with the wired remote control with 12 h timer and with the H-Link adapter.

Compatible with Hi-Kumo

The entire Hitachi residential range is compatible with the Hi-Kumo system, which allows the system to be controlled **from any mobile device** as if it were a remote control.

Fig. 1

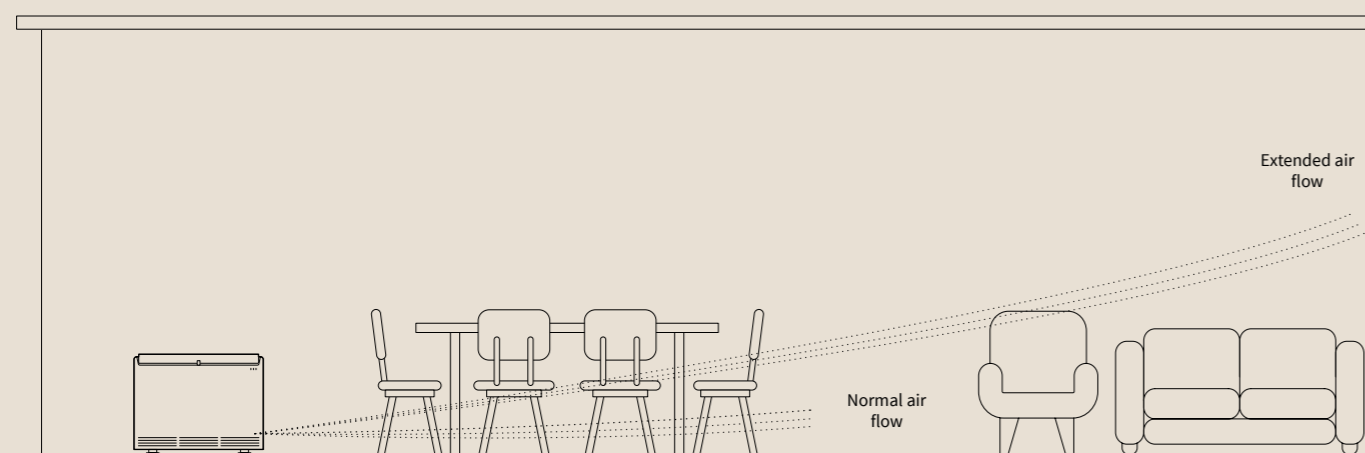

Indoor units

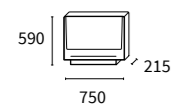

RAF-25RXE
RAF-35RXE
RAF-50RXE

Outdoor units

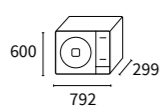

RAC-25FXE
RAC-35FXE

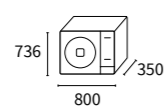

RAC-50FXE

Shirokuma Console

System			Shirokuma F 25 RXE	Shirokuma F 35 RXE	Shirokuma F 50 RXE
Capacity	Cooling (Min/Nom/Max)	kW	0.90-2.50-3.10	0.90-3.50-4.00	0.90-5.00-5.20
	Heating (Min/Nom/Max)	kW	0.90-3.40-4.40	0.90-4.50-5.00	0.90-6.00-8.10
Consumption	Cooling (Min/Nom/Max)	kW	0.25-0.54-1.00	0.25-0.93-1.38	0.50-1.39-2.10
	Heating (Min/Nom/Max)	kW	0.25-0.76-1.20	0.25-1.15-1.50	0.50-1.58-2.70
Electrical power			1 ~230V 50Hz	1 ~230V 50Hz	1 ~230V 50Hz
Indoor/outdoor wiring section (shielded)		mm2	3 x 1.5 + E	3 x 1.5 + E	3 x 2.5 + E
EER			4.65	3.75	3.60
COP			4.50	3.90	3.80
SEER			8.50	8.20	6.80
SCOP			4.60	4.60	4.30
Energy rating (medium zone)	Cooling/Heating		A+++/A+	A+/A++	A++/A+
Outside operating temperatures	Cooling (DB)	°C	-10 to 46	-10 to 46	-10 to 46
	Heating (DB)	°C	-20 to 24	-20 to 24	-20 to 24
Pipe diameter	Liquid-gas	inches	1/4-3/8	1/4-3/8	1/4-1/2
Remote control included			Wireless - RAR-6NE4	Wireless - RAR-6NE4	Wireless - RAR-6NE4
Indoor unit			RAF-25RXE	RAF-35RXE	RAF-50RXE
Air flow (Very low - Low - Medium - High)	Cooling	m3/h	270-390-510-630	270-390-510-660	300-450-540-720
	Heating	m3/h	300-420-540-660	300-420-540-690	330-480-570-750
Sound pressure (Very low - Low - Medium - High)	Cooling	dB(A)	20-26-31-38	20-26-31-39	22-29-36-43
	Heating	dB(A)	20-26-31-38	20-26-31-39	22-29-36-44
Sound power		dB(A)	52	53	57
Dimensions (H x W x D)		mm	590x750x215	590x750x215	590x750x215
Weight		kg	15.0	15.0	15.0
Condensate pipe diameter (out)		mm	16	16	16
Outdoor unit			RAC-25FXE	RAC-35FXE	RAC-50FXE
Air flow	Cooling	m3/h	1,860	1,920	2,160
	Heating	m3/h	1,620	1,620	2,160
Sound pressure	Cooling	dB(A)	45	47	51
	Heating	dB(A)	47	49	53
Sound power		dB(A)	59	61	65
Minimum pipe length		m	3	3	3
Maximum pipe length		m	20	20	30
Maximum height difference		m	10	10	10
Compressor			Rotary	Rotary	Rotary
Refrigerant			R32	R32	R32
Refrigerant charge (length without additional charge)		kg (m)	0.98 (20)	0.98 (20)	1.20 (30)
Additional refrigerant charge		g/m	-	-	-
Dimensions (H x W x D)		mm	600x792x299	600x792x299	736x800x350
Weight		kg	37	37	51

Compatible controls and accessories:

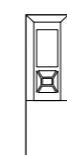

Eco Control
RAR-6NE4
Included



Wired control
SPX-RCDB



Programmable wired control
SPX-WKT3

Others:

- H-Link PSC-6RAD box
- SPX-WFG01 WIFI adapter

The R410A 1x1 systems are the ideal solution for high performance and maximum discretion in properties, shops or small independent spaces within large facilities. Its simple but precise technology ensures optimal comfort whatever the season.



R410A 1x1 Systems



Wall-mounted IVX

Quiet and compact perfect for homes and businesses

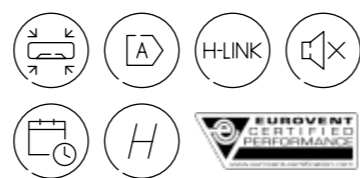

Improved performance at extreme temperatures

This system can work down to -20 °C in heating, and up to 46 °C in cooling.

Built-in expansion valve in the indoor unit

Being located inside the indoor unit ensures a more efficient process and more accurate temperature control.

Smart defrost control

The machine remembers previous defrost cycles and so can use intelligent predictions on when to start the cycle to reduce the length of time heating is suspended. It also detects ice buildup and sends hot gas to the OU so as to avoid activating the defrost cycle at all. (Fig. 1)

Compact unit

Up to 14 kW (6 HP) with a single fan; 0.35 m² of floorspace occupied.

Greater flexibility

The installation of 3 and 4 HP units allows up to 70m of pipe run and 30m of height difference. (Fig. 2)

Easy installation of up to 4 units

Allows independent climate control of up to 4 different spaces. Installation is simplified thanks to a common refrigerant circuit. See the VRF section for combinations and connections

Fig. 1

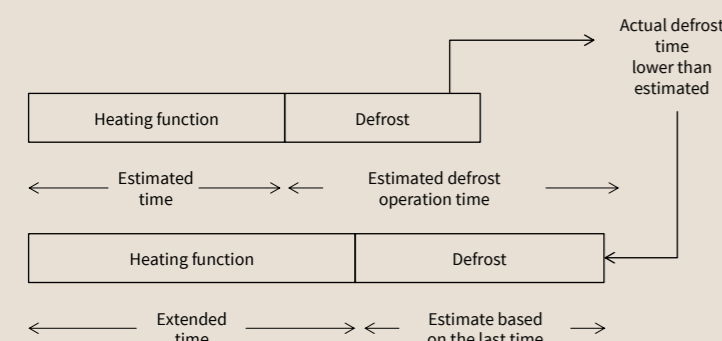
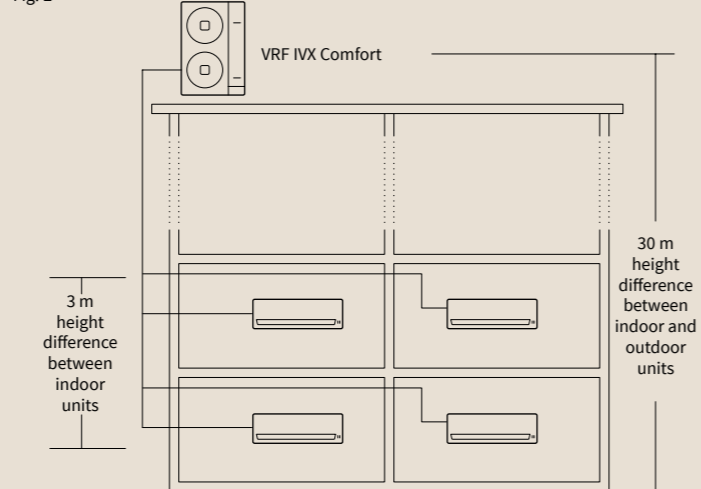
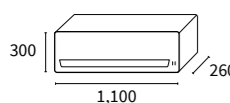

Fig. 2



Indoor units

Outdoor units



RPK-2.0FSN4M
RPK-2.5FSN4M
RPK-3.0FSN4M
RPK-4.0FSN4M

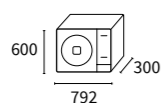

RAS-2HVNP1
RAS-2.5HVNP1
RAS-3HVNC1

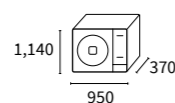

RAS-4H(V)NC1E

Wall-mounted IVX

System			RPK 2 IVX	RPK 2.5 IVX	RPK 3 IVX	RPK 4 IVX
Capacity	Cooling (Min/Nom/Max)	kW	2.20-5.00-5.60	2.20-5.60-6.30	3.20-7.10-8.00	4.50-10.00-11.20
	Heating (Min/Nom/Max)	kW	2.20-5.60-7.10	2.20-6.30-8.00	3.50-8.00-10.60	5.00-11.20-14.00
Consumption	Cooling (nom)	kW	1.55	1.69	2.64	4.65
	Heating (nom)	kW	1.51	1.68	2.73	3.56
Electrical power			1 ~230V 50Hz	1 ~230V 50Hz	1 ~230V 50Hz	1 ~230V 50Hz
			-	-	-	3N ~400V 50 Hz
Indoor/outdoor wiring section (shielded)		mm2	2 x 0.75	2 x 0.75	2 x 0.75	2 x 0.75
EER			3.23	3.31	2.69	2.15
COP			3.70	3.75	2.93	3.15
SEER	Single-phase		5.47	5.24	5.35	5.56
	Three-phase		-	-	-	5.45
SCOP	Single-phase		4.01	4.14	3.80	3.83
	Three-phase		-	-	-	3.83
Energy rating (medium zone)	Cooling/Heating		A/A+	A/A+	A/A	A/A
Outside operating temperatures	Cooling (DB)	°C	-5 to 46	-5 to 46	-5 to 46	-5 to 46
	Heating (WB)	°C	-20 to 15	-20 to 15	-20 to 15	-20 to 15
Pipe diameter	Liquid-gas	inches	1/4-1/2	1/4-1/2	3/8-5/8	3/8-5/8
Indoor unit			RPK-2.0FSN4M	RPK-2.5FSN4M	RPK-3.0FSN4M	RPK-4.0FSN4M
Air flow (Low - Medium - High - Very high)		m3/h	570-660-780-870	720-840-990-1,100	750-930-1,050-1,200	870-1,050-1,200-1,380
Sound pressure (Low - Medium - High - Very high)		dB(A)	31-34-37-40	35-38-42-45	35-40-44-47	41-46-49-51
Sound power		dB(A)	55	60	63	65
Dimensions (H x W x D)		mm	300x1,100x260	300x1,100x260	300x1,100x260	300x1,100x260
Weight		kg	14.5	15.0	15.0	15.0
Condensate pipe diameter (out)		mm	20	20	20	20
Outdoor unit			RAS-2HVNP1	RAS-2.5HVNP1	RAS-3HVNC1	RAS-4H(V)NC1E
Air flow		m3/h	2,436	2,436	2,682	3,720
Sound pressure	Cooling	dB(A)	44	45	48	52
	Heating	dB(A)	46	47	50	54
Sound power		dB(A)	62	63	66	68
N° fans			1	1	1	1
Maximum current	Single-phase	A	13.8	15.8	17.8	15.5
	Three-phase	A	-	-	-	28.5
Minimum pipe length		m	5	5	5	5
Maximum pipe length		m	50	50	50	70
Maximum height difference (highest OU/lowest OU)		m	30/20	30/20	30/20	30/20
Compressor			Scroll DC Inverter	Scroll DC Inverter	Scroll DC Inverter	Scroll DC Inverter
Refrigerant			R-410A	R-410A	R-410A	R-410A
Refrigerant charge (length without additional charge)		kg (m)	1.6 (30)	1.6 (30)	1.9 (20)	3.2 (30)
Additional refrigerant charge		g/m	30	30	40	40
Dimensions (H x W x D)		mm	600x792x300	600x792x300	600x792x300	1,140x950x370
Weight		kg	43.0	43.0	44.0	79.0

Compatible controls and accessories:



Wired control with timer
PC-ARFP1E



Wireless remote control
PC-AWR

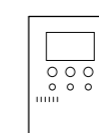

Simplified remote control
PC-ARH

Others:

- Optional functions connector (5 units): PCC- 1A
- Receiver kit for PC- AWR control PC-ALHZ1. Compatible with RPK-FSN(H)3M



Primary ducts

The best value for money



Highly flexible installation

The Primary range of ducts allows the outdoor unit to be installed up to 50m away from the indoor unit and has a potential height difference of 30m: great for installing on roofs out of sight. (Fig. 1)

Built-in drain pan

The new built in drainage tray reduces dust accumulation and prevents water leakage and mold buildup. (Fig. 2)

Extensive static pressure range

Greater flexibility thanks to the extensive range of optional static pressures for long ducts and multi-zone applications.

Extensive range for all types of installations

The extensive Primary range of 3, 4, 5, 6 and 6.5 HP ducts has up to A++ energy efficiency.

Flexible air return from the underneath or at the back

Different circumstances can require flexibility of air intake depending on needs such as space constraints. This intake can be changed without changing the unit. (Fig. 3)

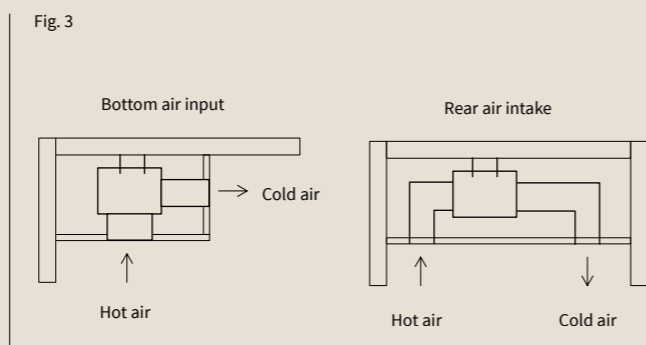
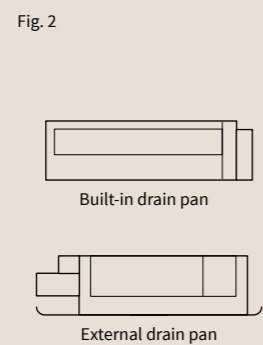
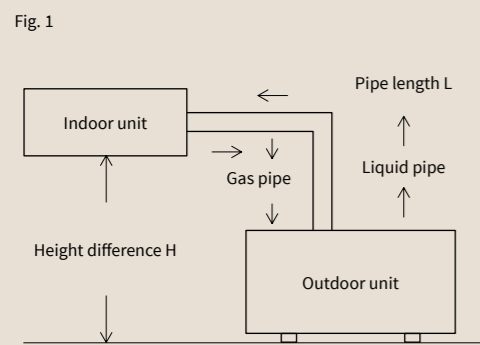

Indoor units

Outdoor units

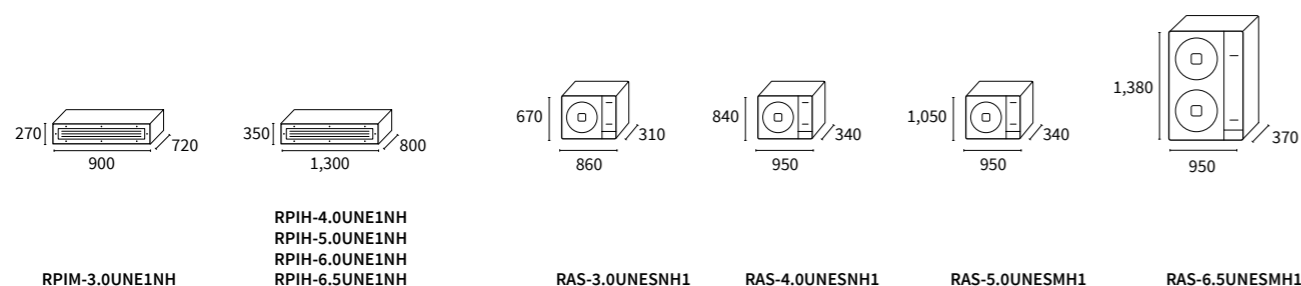

Primary Duct Range

System			RPIM-3.0UNE1NH	RPIH-4.0UNE1NH	RPIH-5.0UNE1NH	RPIH-6.0UNE1NH	RPIH-6.5UNE1NH
Capacity	Cooling (Min/Nom/Max)	kW	2.70-6.80-7.85	2.93-10.10-12.00	3.30-12.03-13.20	3.20-13.48-16.00	4.98-15.76-18.00
	Heating (Min/Nom/Max)	kW	2.77-7.94-8.70	3.32-11.45-13.00	3.00-14.00-14.60	3.40-16.70-18.50	5.20-18.46-20.50
Consumption	Cooling (nom)	kW	2.23	3.31	4.30	4.46	6.06
	Heating (nom)	kW	2.30	3.40	4.10	4.97	5.72
Electrical power			1 ~230V 50Hz	1 ~230V 50Hz	3N ~400V 50 Hz	3N ~400V 50 Hz	3N ~400V 50 Hz
Indoor/outdoor wiring section (shielded)		mm2	4 x 1.5	4 x 1.5	4 x 1.5	4 x 1.5	4 x 1.5
EER			3.05	3.05	2.80	3.02	2.60
COP			3.46	3.38	3.41	3.42	3.23
SEER			6.17	6.23	5.71	6.08	5.99
SCOP			3.85	3.80	3.77	3.78	3.68
Energy rating (medium zone)	Cooling/Heating		A++/A	A++/A	A+/A	A+/A	A+/A
Outside operating temperatures	Cooling (DB)	°C	-15 to 48	-15 to 48	-15 to 48	-15 to 48	-15 to 48
	Heating (DB)	°C	-15 to 24	-15 to 24	-15 to 24	-15 to 24	-15 to 24
Pipe diameter	Liquid-gas	inches	3/8-5/8	3/8-5/8*	3/8-5/8*	3/8-5/8*	3/8-5/8*
Remote control included			Wired - HCWA21NEWH	Wired - HCWA21NEWH	Wired - HCWA21NEWH	Wired - HCWA21NEWH	Wired - HCWA21NEWH
Indoor unit			RPIM-3.0UNE1NH	RPIH-4.0UNE1NH	RPIH-5.0UNE1NH	RPIH-6.0UNE1NH	RPIH-6.5UNE1NH
Air Flow (Low - Medium - High)		m3/h	852-976-1.100	1.050-1.250-1.450	1.300-1.500-1.750	1.900-2.200-2.400	1.900-2.200-2.400
Available pressure (range)		Pa	25 (0-80)	37 (0-120)	50 (0-120)	50 (0-120)	50 (0-120)
Sound pressure (Low - Medium - High)		dB(A)	38-36-34	39-36-35	41-39-35	46-43-40	46-43-40
Sound power		dB(A)	58	62	67	70	72
Dimensions (H x W x D)		mm	270x900x720	350x1,300x800	350x1,300x800	350x1,300x800	350x1,300x800
Weight		kg	32.0	51.0	51.0	51.0	51.0
Condensate pipe diameter (out)		mm	32	32	32	32	32
Condensate pump			Included	Included	Included	Included	Included
Outdoor unit			RAS-3.0UNESNH1	RAS-4.0UNESNH1	RAS-5.0UNESMH1	RAS-6.0UNESMH1	RAS-6.5UNESMH1
Air flow		m3/h	3,000	3,500	5,800	6,200	6,200
Sound Pressure (High)		dB(A)	53	56	58	56	57
Sound power		dB(A)	68	70	74	69	73
N° fans			1	1	1	2	2
Maximum current		A	18.1	22.5	11.6	12.0	13.1
Maximum pipe length		m	50	50	50	50	50
Maximum height difference		m	30	30	30	30	30
Compressor			Rotary	Rotary	Rotary	Rotary	Rotary
Refrigerant			R410A	R410A	R410A	R410A	R410A
Refrigerant charge (length without additional charge)		kg (m)	1.70 (5)	2.80 (5)	3.20 (5)	3.78 (5)	3.95 (5)
Additional refrigerant charge		g/m	35	35	35	35	35
Dimensions (H x W x D)		mm	670x860x310	840x950x340	1,050x950x340	1,386x950x340	1,386x950x340
Weight		kg	51.0	70.0	85.0	113.0	117.0

*Reducer required. If not, install with 3/8-3/4 diameter pipe

Compatible controls and accessories:

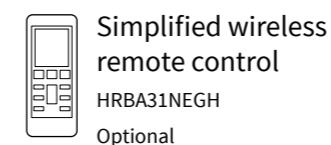
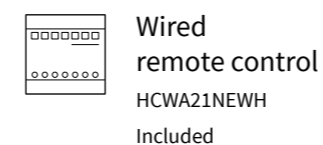

IVX ducts

Quiet and compact, perfect for homes and businesses

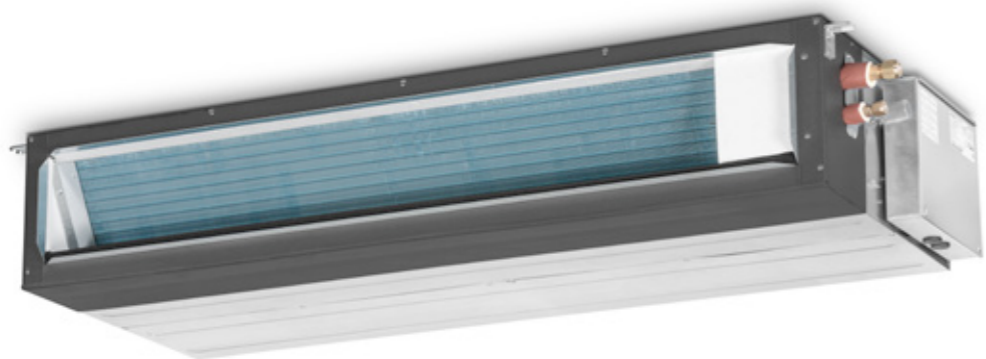
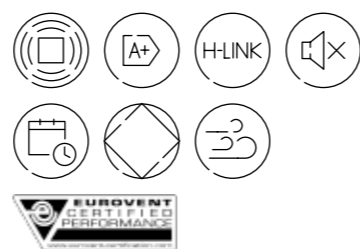

Built-in condensate pump

Hitachi ducts are fitted with a built-in pump to drive the condensate to a downpipe.

Compact unit

Up to 14 kW (6 HP) with a single fan; 0.35 m² of floorspace occupied.

Built-in expansion valve in the indoor unit

Being located inside the indoor unit ensures a more efficient process and more accurate temperature control.

Smart defrost control

The machine remembers previous defrost cycles and so can use intelligent predictions on when to start the cycle to reduce the length of time heating is suspended. It also detects ice buildup and sends hot gas to the OU so as to avoid activating the defrost cycle at all. (Fig. 1)

Greater flexibility

The installation of 3 and 4 HP units allows up to 70m of pipe run and 30m of height difference. (Fig. 2)

Easy installation of up to 4 units

Allows independent climate control of up to 4 different spaces. Installation is simplified thanks to a common refrigerant circuit. See the VRF section for combinations and connections

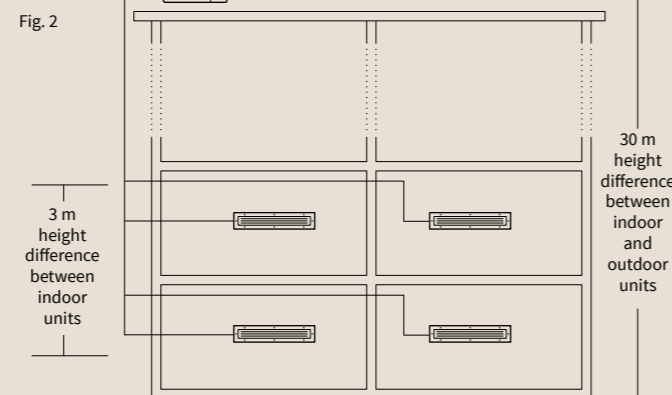
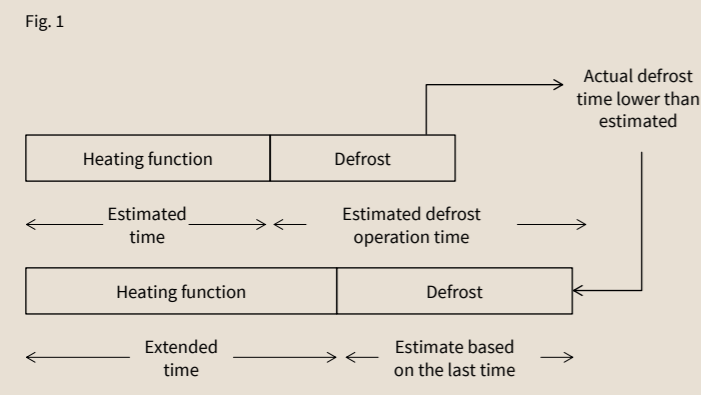

Indoor units

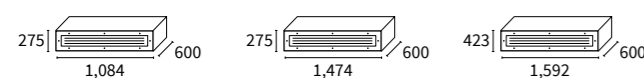

RPI-2.0FSN5E
RPI-2.5FSN5E
RPI-3.0FSN5E

RPI-4.0FSN5E
RPI-5.0FSN5E
RPI-6.0FSN5E

RPI-8.0FSN3E
RPI-10.0FSN3E

Outdoor units

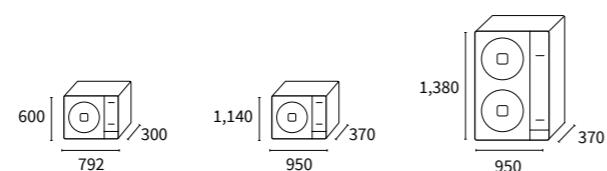

RAS-4H(V)NC1E
RAS-5H(V)NC1E
RAS-6H(V)NC1E

RAS-8HNCE
RAS-10HNCE

IVX ducts

System		RPI 2 IVX	RPI 2.5 IVX	RPI 3 IVX	RPI 4 IVX	RPI 5 IVX	RPI 6 IVX	RPI 8 IVX	RPI 10 IVX
Capacity	Cooling (Min/Nom/Max) kW	2.20-5.00-5.60	2.20-5.60-6.30	3.20-7.10-8.00	4.50-10.00-11.20	5.70-12.50-14.00	6.00-14.00-16.00	8.00-20.00-22.40	10.00-25.00-28.00
	Heating (Min/Nom/Max) kW	2.20-5.60-7.10	2.20-6.30-8.00	3.50-8.00-10.60	5.00-11.20-14.00	5.00-14.00-18.00	5.00-16.00-20.00	6.30-22.40-28.00	8.00-28.00-35.00
Consumption	Cooling (nom) kW	1.41	1.60	2.53	3.10	3.93	4.55	5.95	8.28
	Heating (nom) kW	1.50	1.65	2.26	2.78	3.95	4.40	5.88	7.71
Electrical power		1 ~230V 50Hz	1 ~230V 50Hz	1 ~230V 50Hz	1 ~230V 50Hz	1 ~230V 50Hz	1 ~230V 50Hz	-	-
		-	-	-	3N ~400V 50 Hz	3N ~400V 50 Hz	3N ~400V 50 Hz	3N ~400V 50 Hz	3N ~400V 50 Hz
Indoor/outdoor wiring section (shielded)	mm2	2 x 0.75	2 x 0.75	2 x 0.75	2 x 0.75	2 x 0.75	2 x 0.75	2 x 0.75	2 x 0.75
EER		3.54	3.49	2.81	3.23	3.18	3.08	3.36	3.02
COP		3.73	3.81	3.54	4.03	3.54	3.64	3.81	3.63
SEER	Single-phase	5.60	5.51	4.97	5.27	5.88	5.67	-	-
	Three-phase	-	-	-	5.38	5.84	5.64	6.79	6.61
SCOP	Single-phase	4.01	4.33	3.80	4.01	3.91	3.96	-	-
	Three-phase	-	-	-	4.01	3.90	3.96	4.19	3.79
Energy rating (medium zone)	Cooling/Heating	A+/A+	A/A+	B/A	A/A+	A/B	B/C	-	-
Outside operating temperatures	Cooling (DB) °C	-5 to 46	-5 to 46	-5 to 46	-5 to 46	-5 to 46	-5 to 46	-5 to 46	-5 to 46
	Heating (WB) °C	-20 to 15	-20 to 15	-20 to 15	-20 to 15	-20 to 15	-20 to 15	-20 to 15	-20 to 15
Pipe diameter	Liquid-gas inches	1/4-1/2	1/4-1/2	3/8-5/8	3/8-5/8	3/8-5/8	3/8-5/8	3/8-3/4	3/8-7/8
Indoor unit		RPI-2.0FSN5E	RPI-2.5FSN5E	RPI-3.0FSN5E	RPI-4.0FSN5E	RPI-5.0FSN5E	RPI-6.0FSN5E	RPI-8.0FSN3E	RPI-10.0FSN3E
Air flow (Low - Medium - High)	m ³ /h	600-750-960	780-960-1,140	960-1,140-1,320	1,500-1,680-1,800	1,740-1,920-2,100	1,800-1,980-2,160	3,570-3,960-4,500	4,056-4,500-4,500
Available pressure (range)	Pa	30 (0-120)	30 (0-125)	30 (0-125)	45 (0-120)	50 (0-140)	50 (0-140)	180 (140-220)	180 (140-220)
Sound pressure (Low - Medium - High)	dB(A)	27-29-29	28-30-30	29-31-31	32-35-37	33-35-38	33-36-39	51-54-54	52-55-55
Sound power (high)	dB(A)	55	56	57	62	65	66	77	78
Dimensions (H x W x D)	mm	275x1,084x600	275x1,084x600	275x1,084x600	275x1,474x600	275x1,474x600	275x1,474x600	423x1,592x600	423x1,592x600
Weight	kg	35.0	36.0	36.0	48.0	48.0	48.0	85.0	87.0
Condensate pipe diameter (out)	mm	32	32	32	32	32	32	25	25
Condensate pump		Included	Included	Included	Included	Included	Included	Not included	Not included
Maximum condensate height	mm	850	850	850	850	850	850	-	-
Outdoor unit		RAS-2HVNP1	RAS-2.5HVNP1	RAS-3HVNC1	RAS-4H(V)NC1E	RAS-5H(V)NC1E	RAS-6H(V)NC1E	RAS-8HNCE	RAS-10HNCE
Air flow	m ³ /h	2,436	2,436	2,682	3,720	4,080	4,800	7,620	8,040
Sound pressure	Cooling dB(A)	44	45	48	52	52	55	57	58
	Heating dB(A)	46	47	50	54	54	57	59	60
Sound power	dB(A)	62	63	66	68	69	71	76	76
N° fans		1	1	1	1	1	1	2	2
Maximum current	Single-phase A	13.8	15.8	17.8	15.5	15.0	15.5	-	-
	Three-phase A	-	-	-	28.5	28.0	28.5	24.0	24.0
Maximum pipe length	m	50	50	50	70	75	75	100	100
Maximum height difference (highest OU/lowest OU)	m	30/20	30/20	30/20	30/20	30/20	30/20	30/20	30/20
Compressor		Scroll DC Inverter	Scroll DC Inverter	Scroll DC Inverter	Scroll DC Inverter	Scroll DC Inverter	Scroll DC Inverter	Scroll DC Inverter	Scroll DC Inverter
Refrigerant		R-410	R-410	R410A	R410A	R410A	R410A	R410A	R410A
Refrigerant charge (length without additional charge)	kg (m)	1.6 (30)	1.6 (30)	1.9 (20)	3.2 (30)	3.2 (30)	3.2 (30)	5.7 (30)	6.2 (30)
Additional refrigerant charge	g/m	30	30	40	40	60	60	must be calculated	must be calculated
Dimensions (H x W x D)	mm	600x792x300	600x792x300	600x792x300	1,140x950x370	1,140x950x370	1,140x950x370	1,380x950x370	1,380x950x370
Weight	kg	43.0	43.0	44.0	79.0	89.0	89.0	136.0	138.0

Compatible controls and accessories:

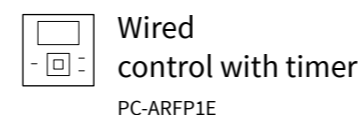

Wired control with timer
PC-ARFP1E

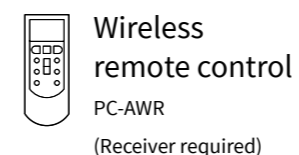

Wireless remote control
PC-AWR
(Receiver required)

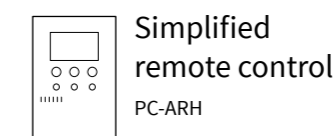

Simplified remote control
PC-ARH

Others:
- SOR-MSK presence sensor kit. Compatible with RPI-(0.4-3.0)FSN5E
- Optional functions connector (5 units) PCC- 1A

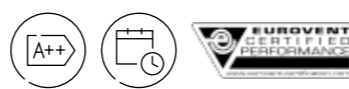

Primary Cassette

The best value for money



Uniform distribution of air in the room

The Primary range cassette-type units allow the air flow to be adjusted according to the user's preferences: horizontal or vertical. The air conditioning flow can also be directed for optimal comfort: it can be distributed throughout the room or positioned so it is directed at a particular point.

(Fig. 1)

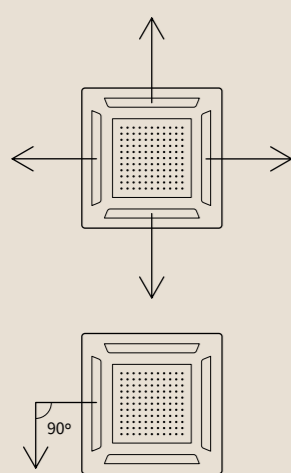

Cool, ventilated environment

These units have a fresh air input from outside to keep the environment fresh and ventilated. They allow approximately 15 m³/h of fresh air flow.

Clean air thanks to the washable easy-access filter.

The cassette filter is washable for easier cleaning and maintenance, always assuring fresh, clean air.

(Fig. 2)

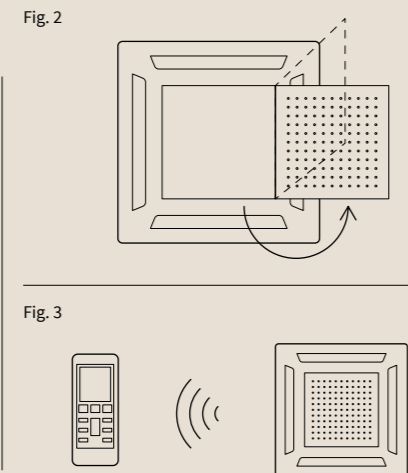

Straightforward control of the unit

The units have a built-in remote sensor for easy control from the remote control.

(Fig. 3)

Smart temperature setting

Fan speed can be adjusted according to the height of the cassette installation using the wireless control. This function corrects any temperature difference in the room to ensure user comfort.

(Fig. 4)

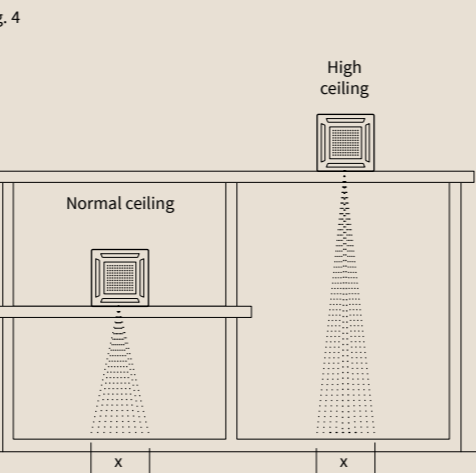

Indoor units

Outdoor units

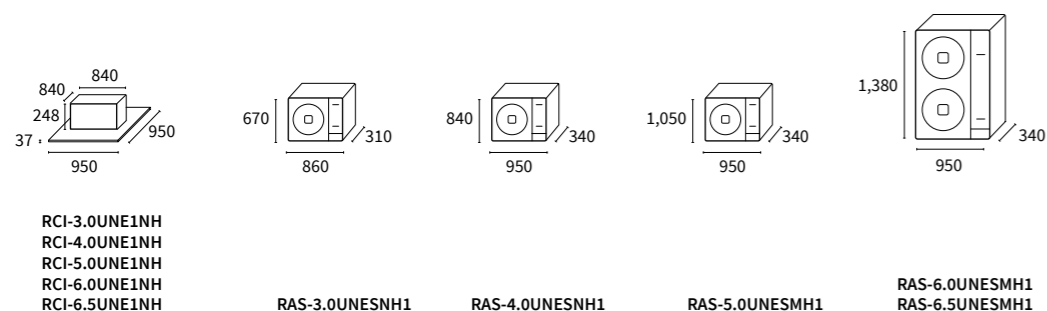

Primary Cassette

System			RCI-3.0UNE1NH	RCI-4.0UNE1NH	RCI-5.0UNE1NH	RCI-6.0UNE1NH	RCI-6.5UNE1NH
Capacity	Cooling (Min/Nom/Max)	kW	2.70-7.07-7.85	2.93-10.30-12.00	3.30-12.07-13.20	3.40-13.40-16.20	4.98-14.50-18.00
	Heating (Min/Nom/Max)	kW	2.77-8.20-8.80	3.32-11.50-13.00	3.00-14.00-14.60	3.30-16.44-18.00	5.00-17.60-21.00
Consumption	Cooling (nom)	kW	2.21	3.43	4.20	4.62	5.50
	Heating (nom)	kW	2.37	3.60	3.90	4.85	5.71
Electrical power			1 ~230V 50Hz	1 ~230V 50Hz	3N ~400V 50 Hz	3N ~400V 50 Hz	3N ~400V 50 Hz
Indoor/outdoor wiring section (shielded)		mm ²	4 x 1.5	4 x 1.5	4 x 1.5	4 x 1.5	4 x 1.5
EER			3.20	3.00	2.88	2.90	2.64
COP			3.46	3.19	3.59	3.39	3.08
SEER			6.46	6.13	5.72	6.01	5.87
SCOP			4.08	3.90	3.80	3.87	3.80
Energy rating (medium zone)	Cooling/Heating		A++/A+	A++/A	A+/A	A+/A	A+/A
Pipe diameter	Liquid-gas	inches	3/8-5/8	3/8-5/8*	3/8-5/8*	3/8-5/8*	3/8-5/8*
Remote control included			Wireless - HRBA31NEGH	Wireless - HRBA31NEGH	Wireless - HRBA31NEGH	Wireless - HRBA31NEGH	Wireless - HRBA31NEGH
Indoor unit			RCI-3.0UNE1NH	RCI-4.0UNE1NH	RCI-5.0UNE1NH	RCI-6.0UNE1NH	RCI-6.5UNE1NH
Air Flow (Low - Medium - High)		m ³ /h	852-976-1.100	1.000-1.300-1.600	1.550-1.700-1.850	1.700-1.900-2.000	1.700-1.900-2.000
Sound pressure (Low - Medium - High)		dB(A)	36-40-43	42-45-49	45-46-50	41-45-52	44-46-52
Sound power		dB(A)	57	61	62	64	62
Cassette dimensions (H x W x D)		mm	248x840x840	248x840x840	298x840x840	298x840x840	298x840x840
Cassette weight		kg	25.0	27.0	32.0	32.0	32.0
Panel dimensions (H x W x D)		mm	37x950x950	37x950x950	37x950x950	37x950x950	37x950x950
Panel weight		kg	6.0	6.0	6.0	6.0	6.0
Condensate pipe diameter (out)		mm	32	32	32	32	32
Condensate pump			Included	Included	Included	Included	Included
Outdoor unit			RAS-3.0UNESNH1	RAS-4.0UNESNH1	RAS-5.0UNESMH1	RAS-6.0UNESMH1	RAS-6.5UNESMH1
Air flow		m ³ /h	3,000	3,500	5,800	6,200	6,200
Sound pressure		dB(A)	53	56	58	56	57
Sound power		dB(A)	68	70	74	69	73
N° fans			1	1	1	2	2
Maximum current		A	18.1	22.5	11.6	11.0	13.1
Maximum pipe length		m	50	50	50	50	50
Maximum height difference (highest OU/lowest OU)		m	30	30	30	30	30
Compressor			Rotary	Rotary	Rotary	Rotary	Rotary
Refrigerant			R-410A	R-410A	R-410A	R-410A	R-410A
Refrigerant charge (length without additional charge)		kg (m)	1.7 (5)	2.8 (5)	3.2 (5)	3.78 (5)	3.95 (5)
Additional refrigerant charge		g/m	35	35	35	35	35
Dimensions (H x W x D)		mm	670x860x310	840x950x340	1,050x950x340	1,386x950x340	1,386x950x340
Weight		kg	51.0	70.0	85.0	113.0	117.0

*Reducer required. If not, install with 3/8-3/4 diameter pipe

Compatible controls and accessories:

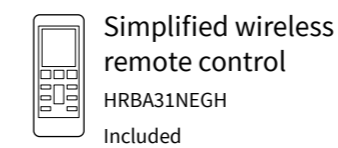

IVX Cassette

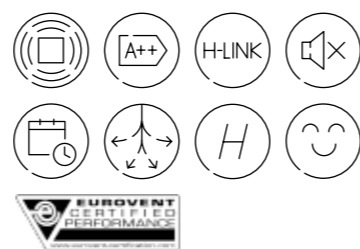

Quiet and compact, perfect for homes and businesses



Built-in condensate pump
Hitachi cassettes are fitted with a built-in pump to drive the condensate to a downpipe.

Presence sensor
A presence sensor can be fitted in order to optimise energy consumption. (Fig. 1)

Built-in expansion valve in the indoor unit
Being located inside the indoor unit ensures a more efficient process and more accurate temperature control.

Smart defrost control
The machine remembers previous defrost cycles and so can use intelligent predictions on when to start the cycle to reduce the length of time heating is suspended. It also detects ice buildup and sends hot gas to the OU so as to avoid activating the defrost cycle at all. (Fig. 1)

Greater flexibility
The installation of 3 and 4 HP units allows up to 70m of pipe run and 30m of height difference. (Fig. 2)

Easy installation of up to 4 units
Allows independent climate control of up to 4 different spaces. Installation is simplified thanks to a common refrigerant circuit.

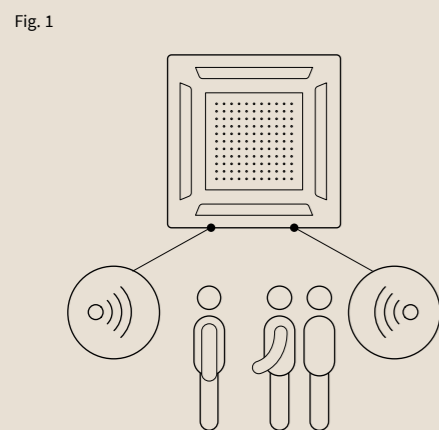
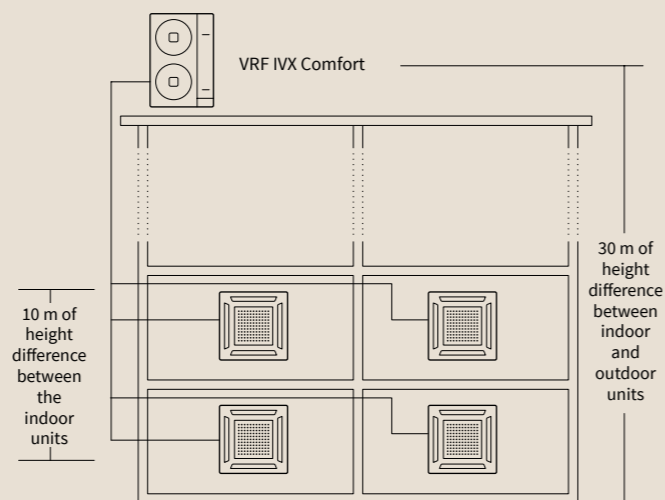
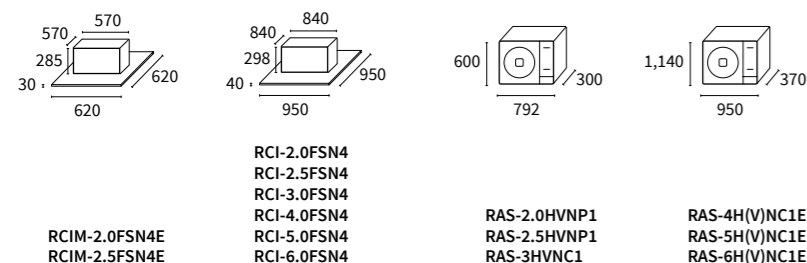

Fig. 2



Indoor units

Outdoor units



IVX Cassette

System			RCIM-2.0FSN4E	RCIM-2.5FSN4E	RCI-2.0FSN4	RCI-2.5FSN4	RCI-3.0FSN4	RCI-4.0FSN4	RCI-5.0FSN4	RCI-6.0FSN4
Capacity	Cooling (Min/Nom/Max)	kW	2.20-5.00-5.60	2.20-5.60-6.30	2.20-5.00-5.60	2.20-5.60-6.30	3.20-7.10-8.00	4.50-10.00-11.20	5.70-12.50-14.00	6.00-14.00-16.00
	Heating (Min/Nom/Max)	kW	2.20-5.60-7.10	2.20-6.30-8.00	2.20-5.60-7.10	2.20-6.30-8.00	3.50-8.00-10.60	5.00-11.20-14.00	5.00-14.00-18.00	5.00-16.00-20.00
Consumption	Cooling (nom)	kW	1.45	1.72	1.24	1.34	2.26	2.70	3.71	4.29
	Heating (nom)	kW	1.47	1.57	1.20	1.28	2.00	2.45	3.60	3.78
Electrical power			1 ~230V 50Hz	1 ~230V 50Hz	1 ~230V 50Hz	1 ~230V 50Hz	1 ~230V 50Hz	1 ~230V 50Hz	1 ~230V 50Hz	1 ~230V 50Hz
			-	-	-	-	- 3N ~400V 50 Hz	3N ~400V 50 Hz	3N ~400V 50 Hz	3N ~400V 50 Hz
Indoor/outdoor wiring section (shielded)		mm2	2 x 0.75	2 x 0.75	2 x 0.75	2 x 0.75	2 x 0.75	2 x 0.75	2 x 0.75	2 x 0.75
EER			3.45	3.25	4.03	4.18	3.14	3.70	3.37	3.26
COP			3.80	4.02	4.68	4.92	4.00	4.57	3.89	4.23
SEER	Single-phase		5.67	5.61	6.49	6.05	6.00	6.57	6.10	5.88
	Three-phase		-	-	-	-	-	6.41	6.06	5.85
SCOP	Single-phase		4.00	4.41	4.67	4.77	4.21	4.47	4.00	4.05
	Three-phase		-	-	-	-	-	4.47	4.00	4.05
Energy rating (medium zone)	Cooling/Heating		A+/A+	A+/A+	A++/A++	A+/A++	A+/A+	A++/A+	A/A	A/B
Outside operating temperatures	Cooling (DB)	°C	-5 to 46	-5 to 46	-5 to 46	-5 to 46	-5 to 46	-5 to 46	-5 to 46	-5 to 46
	Heating (WB)	°C	-20 to 15	-20 to 15	-20 to 15	-20 to 15	-20 to 15	-20 to 15	-20 to 15	-20 to 15
Pipe diameter	Liquid-gas	inches	1/4-1/2	3/8-5/8	1/4-1/2	3/8-5/8	3/8-5/8	3/8-5/8	3/8-5/8	3/8-5/8
Indoor unit			RCIM-2.0FSN4E	RCIM-2.5FSN4E	RCI-2.0FSN4	RCI-2.5FSN4	RCI-3.0FSN4	RCI-4.0FSN4	RCI-5.0FSN4	RCI-6.0FSN4
Air flow (Very low - Low - Medium - High)		m3/h	480-600-720-900	600-720-840-960	660-840-1.020-1.320	840-1.080-1.380-1.620	840-1.080-1.380-1.620	1.200-1.440-1.860-2.220	1.260-1.560-1.980-2.220	1.320-1.680-2.100-2.220
Sound pressure (Very low - Low - Medium - High)		dB(A)	31-35-39-45	35-39-43-47	27-30-32-37	28-32-36-42	28-32-36-42	33-39-43-48	35-40-45-48	37-41-46-48
Sound power		dB(A)	56	60	55	56	57	64	64	64
Cassette dimensions (H x W x D)		mm	285-570-570	285-570-570	248x840x840	248x840x840	298x840x840	298x840x840	298x840x840	298x840x840
Cassette weight		kg	17.0	17.0	21.0	22.0	26	26	26	26
Panel dimensions (H x W x D)		mm	30x620x620	30x620x620	40x950x950	40x950x950	40x950x950	40x950x950	40x950x950	40x950x950
Panel weight		kg	2.5	2.5	6.5	6.5	6.5	6.5	6.5	6.5
Condensate pipe diameter (out)		mm	32	32	32	32	32	32	32	32
Condensate pump			Included	Included	Included	Included	Included	Included	Included	Included
Maximum condensate height		mm	850	850	850	850	850	850	850	850
Outdoor unit			RAS-2.0HVNP1	RAS-2.5HVNP1	RAS-2.0HVNP1	RAS-2.5HVNP1	RAS-3.0HVNP1	RAS-4H(V)NC1E	RAS-5H(V)NC1E	RAS-6H(V)NC1E
Air flow		m3/h	2,436	2,436	2,436	2,436	2,682	3,720	4,080	4,800
Sound pressure	Cooling	dB(A)	44	45	44	45	48	52	52	55
	Heating	dB(A)	46	47	46	47	50	54	54	57
Sound power		dB(A)	62	63	62	63	66	68	69	71
N° fans			1	1	1	1	1	2	2	2
Maximum current	Single-phase	A	13.8	15.8	13.8	15.8	17.8	15.5	15.0	15.5
	Three-phase	A	-	-	-	-	-	28.5	28.0	28.5
Minimum pipe length		m	5	5	5	5	5	5	5	5
Maximum pipe length		m	50	50	50	50	50	70	75	75
Maximum height difference (highest OU/lowest OU)		m	30/20	30/20	30/20	30/20	30/20	30/20	30/20	30/20
Compressor			Scroll DC Inverter	Scroll DC Inverter	Scroll DC Inverter	Scroll DC Inverter	Scroll DC Inverter	Scroll DC Inverter	Scroll DC Inverter	Scroll DC Inverter
Refrigerant			R-410A	R-410A	R-410A	R-410A	R-410A	R-410A	R-410A	R-410A
Refrigerant charge (length without additional charge)		kg (m)	1.6 (30)	1.6 (30)	1.6 (30)	1.6 (30)	1.9 (30)	3.2 (30)	3.2 (30)	3.2 (30)
Additional refrigerant charge		g/m	30	30	30	30	40	40	60	60
Dimensions (H x W x D)		mm	600x792x300	600x792x300	600x792x300	600x792x300	600x792x300	1,140x950x370	1,140x950x370	1,140x950x370
Weight		kg	43.0	43.0	43.0	43.0	44.0	79.0	89.0	89.0

Compatible controls and accessories:

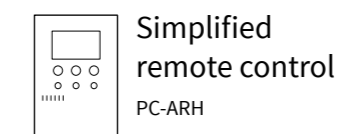
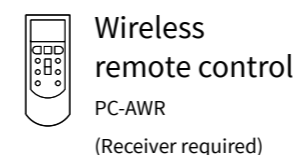

- Others:**
- PS-MSK2 Presence sensor kit. Compatible with RCI-FSN4
 - Optional functions connector (5 units PCC-1A)
 - SOR NEC Presence sensor kit. Compatible with RCIM-FSN4

Primary floor-ceiling

The best value for money

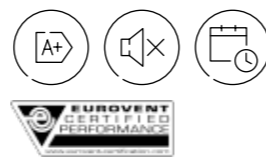

Greater durability of the units

Integrated high strength steel and PS design enhances the durability of the drain pan and improves both thermal insulation and condensate removal functions. (Fig. 1)

Less noise in the room

The plastic fan housing is effective in reducing noise level.

Fresh air inlet

Allows fresh air intake to improve indoor ventilation and air quality.

Flexibility in positioning: allows floor or ceiling installation

The Hitachi Primary range console can be installed both on the floor and on the ceiling, allowing the user to choose the most optimal room location for maximum comfort. (Fig. 2)

Fig. 1

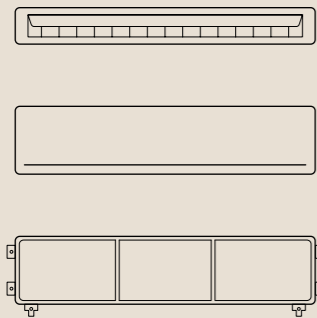
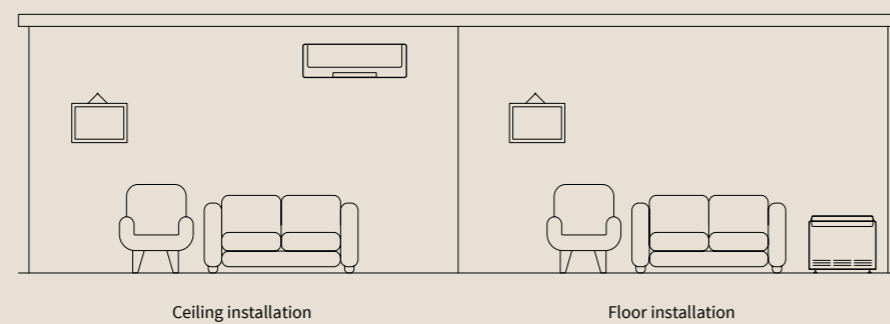
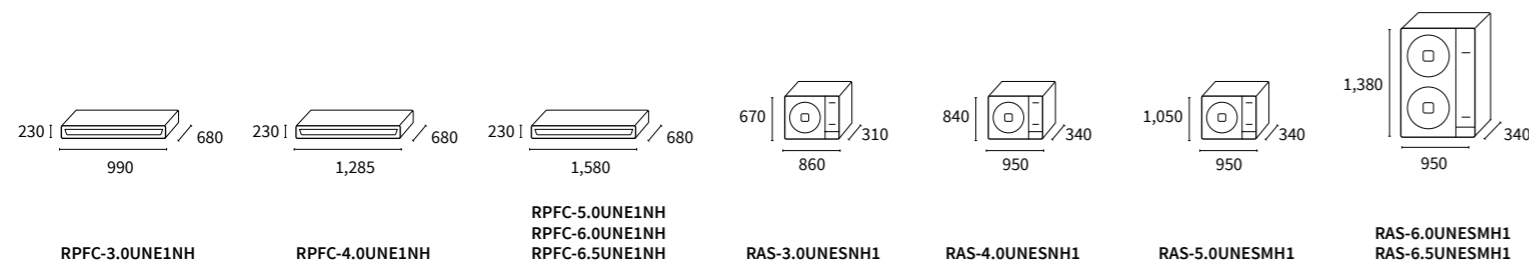

Fig. 2



Indoor units

Outdoor units



Primary floor-ceiling

System			RPFC-3.0UNE1NH	RPFC-4.0UNE1NH	RPFC-5.0UNE1NH	RPFC-6.0UNE1NH	RPFC-6.5UNE1NH
Capacity	Cooling (Min/Nom/Max)	kW	2.70-6.75-7.85	2.80-10.23-11.00	3.30-12.05-13.20	3.10-12.87-16.10	4.98-14.42-18.00
	Heating (Min/Nom/Max)	kW	2.77-8.21-9.20	3.32-11.25-12.00	3.00-14.00-14.60	3.30-16.12-18.00	5.20-17.56-21.00
Consumption	Cooling (nom)	kW	2.16	3.70	4.87	4.25	5.40
	Heating (nom)	kW	2.40	3.75	4.50	5.15	6.40
Electrical power			1 ~230V 50Hz	1 ~230V 50Hz	3N ~400V 50 Hz	3N ~400V 50 Hz	3N ~400V 50 Hz
Indoor/outdoor wiring section (shielded)		mm2	4 x 1.5	4 x 1.5	4 x 1.5	4 x 1.5	4 x 1.5
EER			3.12	2.78	2.48	3.03	2.68
COP			3.43	3.00	3.11	3.13	2.75
SEER			5.79	6.07	5.41	5.99	5.90
SCOP			3.92	3.97	3.79	3.80	3.80
Energy rating (medium zone)	Cooling/Heating		A+/A	A+/A	A/A	A+/A	A+/A
Outside operating temperatures	Cooling (DB)	°C	-15 to 48	-15 to 48	-15 to 48	-15 to 48	-15 to 48
	Heating (DB)	°C	-15 to 24	-15 to 24	-15 to 24	-15 to 24	-15 to 24
Pipe diameter	Liquid-gas	inches	3/8-5/8	3/8-5/8*	3/8-5/8*	3/8-5/8*	3/8-5/8*
Remote control included			Wireless - HRBA31NEGH	Wireless - HRBA31NEGH	Wireless - HRBA31NEGH	Wireless - HRBA31NEGH	Wireless - HRBA31NEGH
Indoor unit			RPFC-3.0UNE1NH	RPFC-4.0UNE1NH	RPFC-5.0UNE1NH	RPFC-6.0UNE1NH	RPFC-6.5UNE1NH
Air Flow (Low - Medium - High)		m3/h	800-950-1.100	1.300-1.500-1.700	1.600-1.800-2.000	1.200-1.600-2.000	1.500-1.700-2.000
Sound pressure (Low - Medium - High)		dB(A)	45-48-51	49-51-52	47-50-52	42-48-53	47-50-53
Sound power		dB(A)	63	64	66.00	67	66.00
Dimensions (H x W x D)		mm	230x990x680	230x1,285x680	230x1,580x680	230x1,580x680	230x1,580x680
Weight		kg	30	37	48	48	50
Condensate pipe diameter (out)		mm	25	25	25	25	25
Outdoor unit			RAS-3.0UNESNH1	RAS-4.0UNESNH1	RAS-5.0UNESMH1	RAS-6.0UNESMH1	RAS-6.5UNESMH1
Air flow		m3/h	3,000	3,500	5,800	6,200	6,200
Sound pressure		dB(A)	53	56	58	56	57
Sound power		dB(A)	68	70	74	69	73
N° fans			1	1	1	2	2
Maximum current		A	18.0	22.5	11.6	11.0	13.5
Maximum pipe length		m	50	50	50	50	50
Maximum height difference (highest OU/lowest OU)		m	30	30	30	30	30
Compressor			Rotary	Rotary	Rotary	Rotary	Rotary
Refrigerant			R-410A	R-410A	R-410A	R-410A	R-410A
Refrigerant charge (length without additional charge)		kg (m)	1.7 (5)	2.8 (5)	3.2 (5)	3.78 (5)	3.95 (5)
Additional refrigerant charge		g/m	35	35	35	35	35
Dimensions (H x W x D)		mm	670x860x310	840x950x340	1,050x950x340	1,386x950x340	1,386x950x340
Weight		kg	51.0	70.0	85.0	113.0	117.0

Compatible controls and accessories:

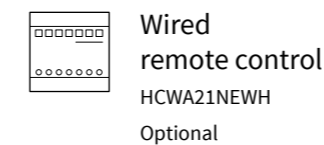

Ceiling-mounted IVX

Quiet and compact, perfect for homes and businesses



Improved performance at extreme temperatures

This system can work down to -20 °C in heating, and up to 46 °C in cooling.

Uniform temperature without drafts

The new design of the large automatic louvre achieves a more uniform temperature in the room and reduces cold drafts.

Flexible installation in high ceilings

The system is fitted with additional speed, high 2, now allowing 4 speeds. High speed does not need to be set using the remote control in the case of high ceilings.

Presence sensor

A presence sensor can be fitted in order to optimise energy consumption.

Greater flexibility

The installation of 3 and 4 HP units allows up to 70m of pipe run and 30m of height difference.

Easy installation of up to 4 units

Allows independent climate control of up to 4 different spaces. Installation is simplified thanks to a common refrigerant circuit.

Fig. 1

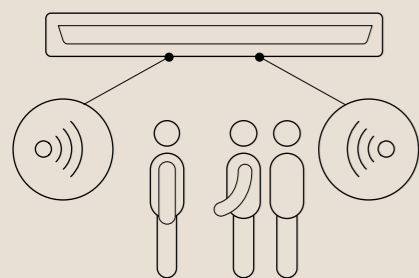
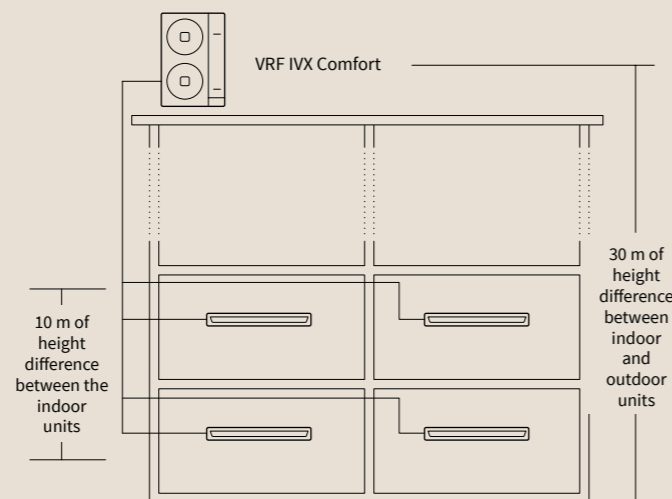
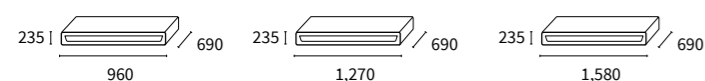

Fig. 2



Indoor units



RPC-2.0FSN3

RPC-2.5FSN3
RPC-3.0FSN3

RPC-4.0FSN3
RPC-5.0FSN3
RPC-6.0FSN3

Outdoor units

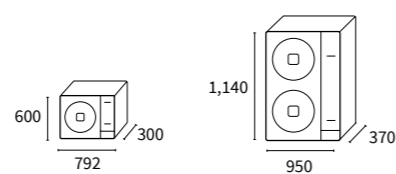

RAS-2HVN1
RAS-2.5HVN1
RAS-3HVC1

RAS-4H(V)NC1E
RAS-5H(V)NC1E
RAS-6H(V)NC1E

Ceiling-mounted IVX

System			RPC 2 IVX	RPC 2.5 IVX	RPC 3 IVX	RPC 4 IVX	RPC 5 IVX	RPC 6 IVX
Capacity	Cooling (Min/Nom/Max)	kW	2.20-5.00-5.60	2.20-5.60-6.30	3.20-7.10-8.00	4.50-10.00-11.20	5.70-12.50-14.00	6.00-14.00-16.00
	Heating (Min/Nom/Max)	kW	2.20-5.60-7.10	2.20-6.30-8.00	3.50-8.00-10.60	5.00-11.20-14.00	5.00-14.00-18.00	5.00-16.00-20.00
Consumption	Cooling (nom)	kW	1.34	1.41	2.29	3.25	4.60	5.49
	Heating (nom)	kW	1.38	1.53	2.33	2.91	3.94	4.40
Electrical power			1 ~230V 50Hz	1 ~230V 50Hz	1 ~230V 50Hz	1 ~230V 50Hz	1 ~230V 50Hz	1 ~230V 50Hz
			-	-	-	3N ~400V 50 Hz	3N ~400V 50 Hz	3N ~400V 50 Hz
Indoor/outdoor wiring section (shielded)		mm2	2 x 0.75	2 x 0.75	2 x 0.75	2 x 0.75	2 x 0.75	2 x 0.75
EER			3.72	4.00	3.10	3.08	2.72	2.55
COP			4.06	4.12	3.43	3.85	3.55	3.64
SEER	Single-phase		5.63	5.49	5.29	5.02	5.74	5.56
	Three-phase		-	-	-	4.93	5.71	5.53
SCOP	Single-phase		4.44	4.49	4.13	3.90	4.00	4.04
	Three-phase		-	-	-	3.90	4.00	4.04
Energy rating (medium zone)	Cooling/Heating		A+/A+	A/A+	A/A+	B/A	D/B	E/A
Outside operating temperatures	Cooling (DB)	°C	-5 to 46	-5 to 46	-5 to 46	-5 to 46	-5 to 46	-5 to 46
	Heating (WB)	°C	-20 to 15	-20 to 15	-20 to 15	-20 to 15	-20 to 15	-20 to 15
Pipe diameter	Liquid-gas	inches	1/4-5/8	3/8-5/8	3/8-5/8	3/8-5/8	3/8-5/8	3/8-5/8
Indoor unit			RPC-2.0FSN3	RPC-2.5FSN3	RPC-3.0FSN3	RPC-4.0FSN3	RPC-5.0FSN3	RPC-6.0FSN3
Air flow (Low - Medium - High - Very high)		m3/h	540-660-780-900	690-840-990-1.140	750-930-1.110-1.260	1.020-1.320-1.590-1.800	1.200-1.530-1.860-2.100	1.260-1.620-1.950-2.220
Sound pressure (Low - Medium - High - Very high)		dB(A)	28-31-35-38	28-31-35-38	29-33-37-40	32-37-42-44	35-41-45-48	36-42-47-49
Sound power		dB(A)	54	54	56	60	64	65
Dimensions (H x W x D)		mm	235x960x690	235x1,270x690	235x1,270x690	235x1,270x690	235x1,270x690	235x1,270x690
Weight		kg	27.0	35.0	35.0	41.0	41.0	41.0
Condensate pipe diameter (out)		mm	25	25	25	25	25	25
Outdoor unit			RAS-2HVN1	RAS-2.5HVN1	RAS-3HVC1	RAS-4H(V)NC1E	RAS-5H(V)NC1E	RAS-6H(V)NC1E
Air flow		m3/h	2,436	2,436	2,682	3,720	4,080	4,800
Sound pressure	Cooling	dB(A)	44	45	48	52	52	55
	Heating	dB(A)	46	47	50	54	54	57
Sound power		dB(A)	62	63	66	68	69	71
N° fans			1	1	1	1	1	1
Maximum current	Single-phase	A	13.8	15.8	17.8	15.5	15.0	15.5
	Three-phase	A	-	-	-	28.5	28.0	28.5
Minimum pipe length		m	5	5	5	5	5	5
Maximum pipe length		m	50	50	50	70	75	75
Maximum height difference (highest OU/lowest OU)		m	30/20	30/20	30/20	30/20	30/20	30/20
Compressor			Scroll DC Inverter	Scroll DC Inverter	Scroll DC Inverter	Scroll DC Inverter	Scroll DC Inverter	Scroll DC Inverter
Refrigerant			R-410A	R-410A	R-410A	R-410A	R-410A	R-410A
Refrigerant charge (length without additional charge)		kg (m)	1.6 (30)	1.6 (30)	1.9 (20)	3.2 (30)	3.2 (30)	3.2 (30)
Additional refrigerant charge		g/m	30	30	40	40	60	60
Dimensions (H x W x D)		mm	600x792x300	600x792x300	600x792x300	1,140x950x370	1,140x950x370	1,140x950x370
Weight		kg	43.000	43.000	44.0	79.0	89.0	89.0

Compatible controls and accessories:

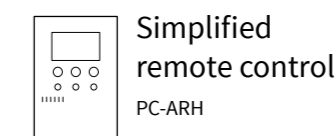
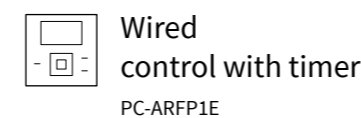

Others:
- SOR-NEP presence sensor kit. Compatible with RPC-FSN3
- Optional functions connector (5 units) PCC- 1A

Controls Residential



Wired control
SPX-RCDA

- Wall-mounted.
- 12 h timer.
- "Away-from-home" mode.
- Multifunction: operating modes, temperatures, ventilation, night mode.

Compatibility:
All Ducted RAD units.



Wired control
SPX-RCDB

- Wall-mounted.
- 12 h timer.
- "Away-from-home" mode.
- Multifunction: operating modes, temperatures, ventilation, night mode.

Compatibility:
All Wall mounted RAK, Cassette RAI and Console RAF units.



Eco Control
SPX-RCKA, SPX-RCKA1, SPX-RCKA2, SPX-RCKA3

- LCD screen.
- Weekly timer.
- Away-from-home mode.
- Eco mode.
- Sleep (7h).
- Multifunction: Weekly timer, range of operating modes, temperature control, ventilation, self-diagnosis and more...

Compatibility:
SPX-RCKA: RAD 50-70PPA, RAD 18-50RPA.
SPX-RCKA1: RAD 18-50QPB, RAD 18-70PPD, RAD 25-60RPE.
SPX-RCKA2: RAK 50-70PPD, RAK 50RPE1, RAK 60RPE.
SPX-RCKA3: RAI 50-60PPD, RAI 25-60RPE.

1x1 Commercial Range



Wired control
PC-ARH

- LCD screen.
- Two or more units can be controlled simultaneously. The units must be interconnected with control cables.
- Multifunctions: mode, temperature, ventilation, clock, etc.
- Specific function, "Identification of parallel indoor units".

Compatibility: vRF range - residential range indoor units, System Free indoor units.



Wireless remote control
PC-AWR

- Control of 1 to 16 indoor units (master and slave).
 - Compact size.
 - Simplified functions: ON/OFF, mode, temperature, ventilation.
- Compatibility: PC-AWR, VRF range - indoor units range 1x1 VRF IVX systems (Comfort and Premium), System Free indoor units.



Wired control with timer
PC-ARFP1E

- Weekly Timer.
- Operating parameters configuration and adjustment.
- Multifunction: Timer for remote ON/OFF options, fault report, automatic routing.
- Control of 1 to 16 indoor units.
- Self-diagnosis, anti-freezing and temperature reduction.
- Built-in environmental sensor.
- Several languages.
- LCD screen.
- Easy to use

Compatibility: Combinations of the VRF IVX Comfort and VRF IVX Premium ranges.

Primary Range

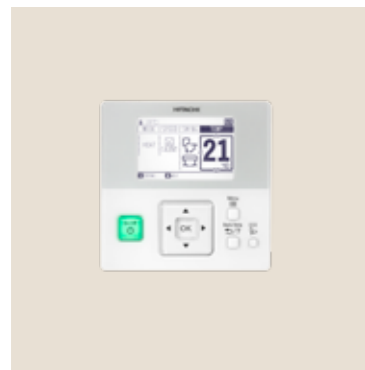

Wired control
SPX-WKT3

- Wall-mounted.
- Weekly timer.
- Away-from-home.
- Multifunction: modes, temperatures, ventilation, night mode.
- Management of up to 13 indoor units.
- With choice of temperature sensor location.

Compatibility: RAK-50-60PPD, RAK 18-35PSB, RAK 18-35PSC, RAI 25-50QPB, RAK 15QPB, RAK 15QPC, RAK 18-50RPB, RAK 35-50RPC, RAK 18-25RPC, RAK 15QPD, RAK 18-50RPD, RAK 18QXB, RAK 25-50RXB, RAK 18QXD, RAK 25-50RXD, RAD 18-50QPB, RAD 50-70PPD, RAI 25-50QPB, RAI 50-60PPD, RAF-25-50RXB.



Primary range wireless control
HRBA31NEGH

- Wireless.
- Simple timer.



Primary range wired control
HCWA21NEWH

- Wall-mounted.
- Weekly timer.
- Multifunction.
- Blocking function.
- With choice of temperature sensor location.
- Alarm codes.



Infra-red receiver for ceiling
PC-ALHP1

- Infra-red receiver for remote control.
- Seamless integration in the unit.

Compatibility: PC-AWR control Ceiling-mounted RPC-FSN3.



Infra-red receiver for wall
PC-ALHZ1

- Infra-red receiver for remote control.
- Seamless integration in the unit.

Compatibility: PC-AWR control RPI-FSN(3-5)(P)E, RCI-FSN4 RCIM-FSN4E, RCD-FSN3 RPK-FSN(H)3M, RPC-FSN3.

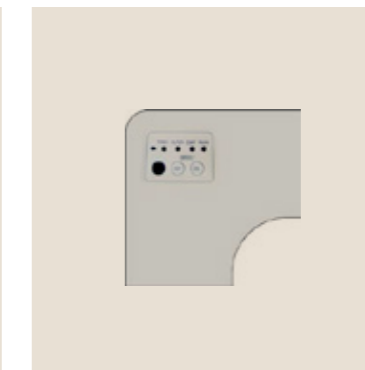

Infra-red receiver for cassette
PC-ALH3

- Infra-red receiver for remote control.
- Seamless integration in the unit.

Compatibility: PC-AWR control RCI-FSN4 Cassette.

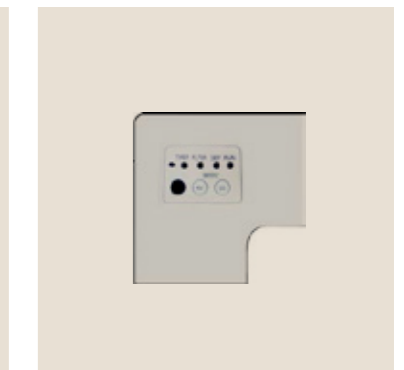

Infra-red receiver for cassette
PC-ALHC1

- Infra-red receiver for remote control.
- Seamless integration in the unit.

Compatibility: PC-AWR control RCIM-FSN4E cassette.

Accessories

Residential

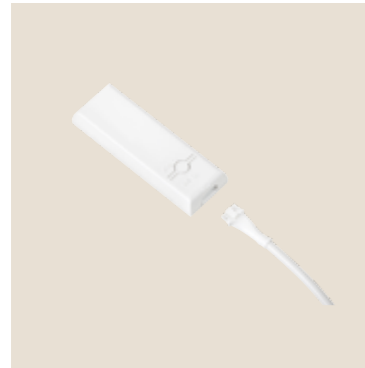

Wi-Fi adapter
SPX-WFG01

- Wi-Fi adapter for Hi-Kumo app.
- Connect the air conditioning using the Hi-Kumo mobile app.

Compatibility: SPX-WFG01, RAK-18 ~ 35PSB, RAK-25 ~ 50RXB, RAK-18QXB, RAK-18 ~ 50RPC, RAK-15QPB, RAF-25 ~ 50RXB, RAI-25 ~ 50QPB, RAD-18 ~ 50QPB. All R32 Units



Wi-Fi adapter
SPX-TAG01

- Wi-Fi adapter for Hi-Kumo app.
- Connect the air conditioning using the Hi-Kumo app.
- Requires Hi-Box AHP-SMB-01.

Compatibility: SPX-TAG01, RAK-RPB, RAK-RPC, RAK-PPA, RAK-QXB/RXB, RAK-PSB, RAK-PSC, RAF-RXB, RAF-RPA, RAI-QPB, RAD-RPA/PPA, RAD-QPB, RAI-RPA.

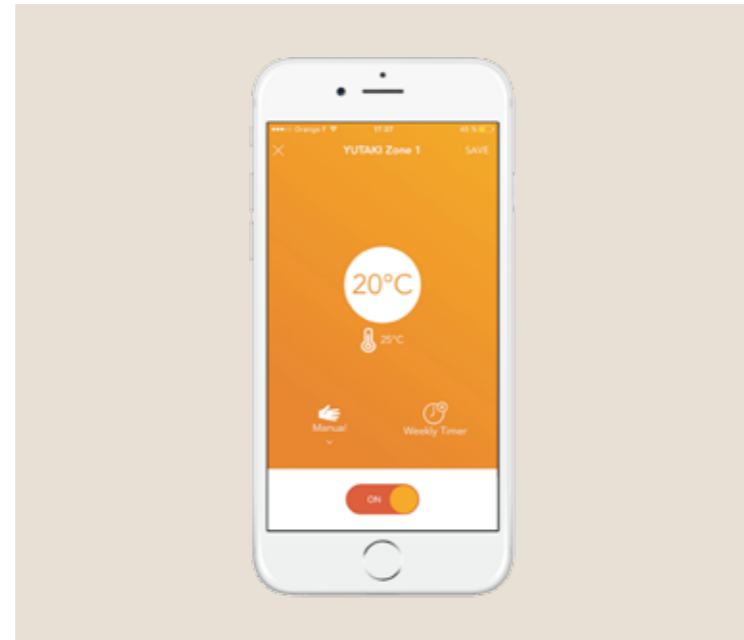

How to enjoy Hi-Kumo?

1. The Hi-Box pack, made up of two accessories, can be used to connect the units to a Wi-Fi network.
2. Download the app to your smartphone, tablet or computer.
3. Configure by simply searching for connected units and pairing them with the app.



Hi-box
AHP-SMB-01

- Accessory for SPX-TAG-01 Wi-Fi adapter.
- This ensures compatibility with the Hi-Kumo app to manage the air conditioning installation from any mobile device.

Compatibility: **AHP-SMB-01:** RAK-RPB, RAK-RPC, RAK-PPA, RAK-QXB / RXB, RAK-PSB, RAK-PSC, RAF-RXB, RAF-RPA, RAI-QPB, RAD-RPA / PPA, RAD-QPB, RAD-QPB.



H-Link Box
PSC-6RAD

- Allows the indoor units of the residential range to be connected to an H-Link network.

Compatibility: **PSC-6RAD**
The entire residential range.



Filter with active carbon base
SPX-CFH25 / SPX-NTW3 / SPX-NTW4

- This filter is mixed with a silver-based antibacterial substance.
- Long-lasting antimicrobial effect.
- Inhibits the growth of bacteria.
- Blocks any kind of smell.
- Can eliminate viruses, thus ensuring hygiene on the surface of products.

Compatibility: **SPX-CFH25** RAK-18~35PSB, RAK-18~35PSC, RAK-15QPB, RAK-18~50RPB, RAK-18~50RPC, RAK-15QPC, RAF-25~50RPA, RAF-25~50RXB, RAK-25~50RXB, RAK-18QXB, **SPX-NTW3:** RAK-60PPA, RAK-RPA, RAI-QPB.

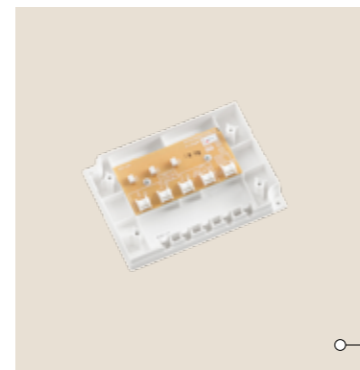

Distributor
SPX-DST1

- Accessory required to connect up to 13 indoor units with the SPX-WKT3 remote control.
- Use the SPX-WDST8M cable if more length is needed

Compatibility: **SPX-DST1** RAI 25~50QPB, RAD 18~50QPB, RAK 18~35PSB, RAK 18~35PSC, RAF 25~50RXB, RAK 15QPB, RAK 18~50RPB, RAK 18~50RPC, RAK 15QPC.

1x1 Commercial Range

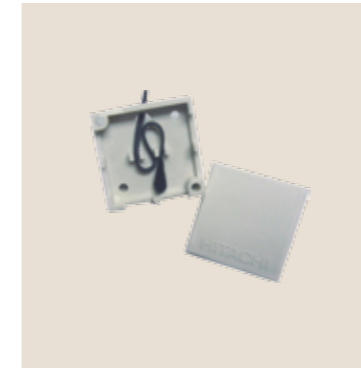

Remote temperature sensor
THM-R2AE

- Fitted with a diverted sensor, regulating relative to ambient temperature.

Compatibility: Combinations of the VRF IVX Comfort and VRF IVX Premium ranges.



Drainage pipe connection kit
DBS 26

- Evacuation drainage 32 mm.
- One kit per module.
- For VRF IVX Premium, it is only used in roof-mounted installations.

Compatibility: DBS26 RAS - 3HVNP. RAS - 4 ~ 6H(V)N(P/C)E RAS 8 ~ 10H(V)N(P/C)E 12HN(P/C).



Drainage pipe connection kit for IVX
DBS 12L

- Evacuation drainage 15 mm.

Compatibility: DBS 12L RAS - 2~2.5 HVNP. RAS - 3HVNC.

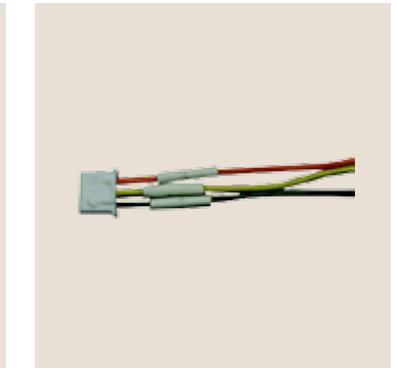

Optional functions connectors
PCC-1A

- Delivered in bags of 5 connector units.
- They allow all available contacts in the outdoor groups and the indoor units and centralised commands to be used (fault report, start/stop, remote).

Compatibility: Combinations of the VRF IVX Comfort and VRF IVX Premium ranges.

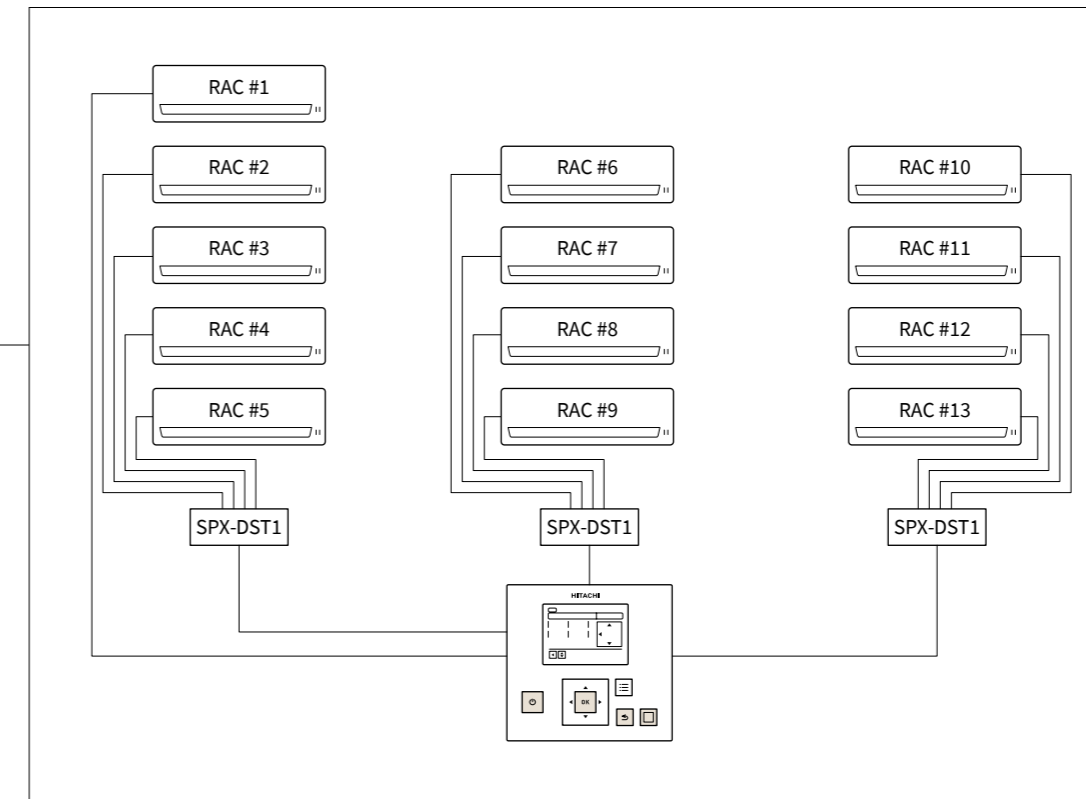

*All 1x1 accessories are compatible with Multizone

Thanks to its flexibility and high capacity, the Multizone range can condition up to 6 different spaces with a single outdoor unit. Its wide range of combinations ensures freedom to adapt to the installation



R32 Multizone

Multizone + ACS



Multizone

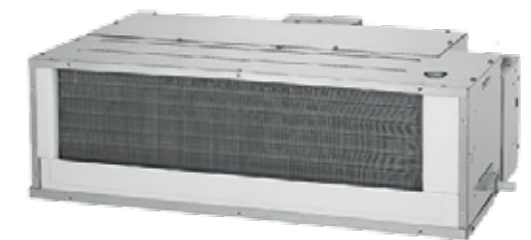

Benefits Multizone

1 Suitably sized systems to fit perfectly in any space

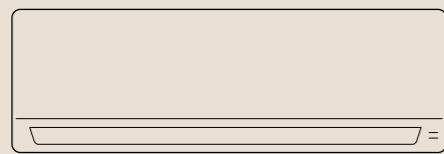

Ideal for small properties, reducing consumption and ensuring the installation is not oversized.

2 Air conditioning system that simplifies installation and maintenance

- The duct-type units allow the static pressure to be modified according to the needs of each installation.
- Reduced pipe diameter, bringing installation cost savings thanks to having smaller pipes.
- Refrigerant pre-charged at factory for 2x1 outdoor units, bringing savings in terms of installation time and cost by removing the need to add further refrigerant.
- Alarm code indicator, saving diagnosis time.

3 Extensive range

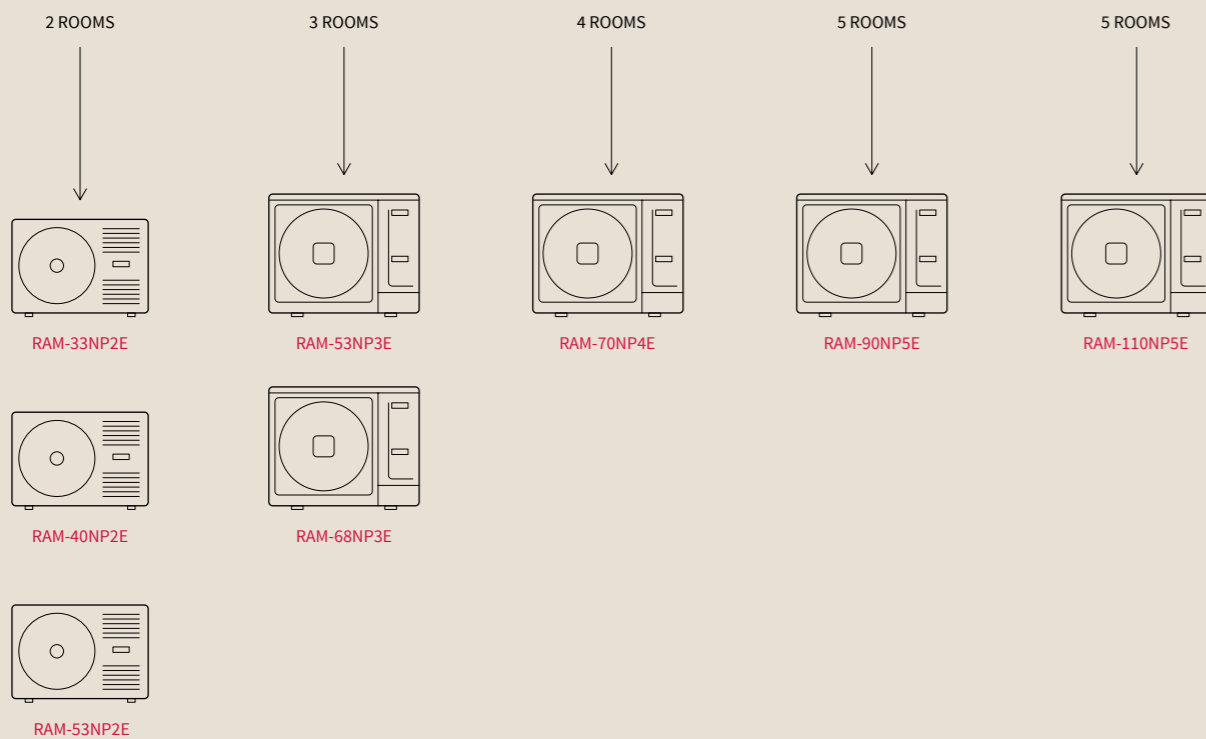

More than 300 possible combinations with the Multizone indoor units range. 8 outdoor units can be combined with 5 indoor units.

4 Air conditioning solutions that fit perfectly with the characteristics of each installation

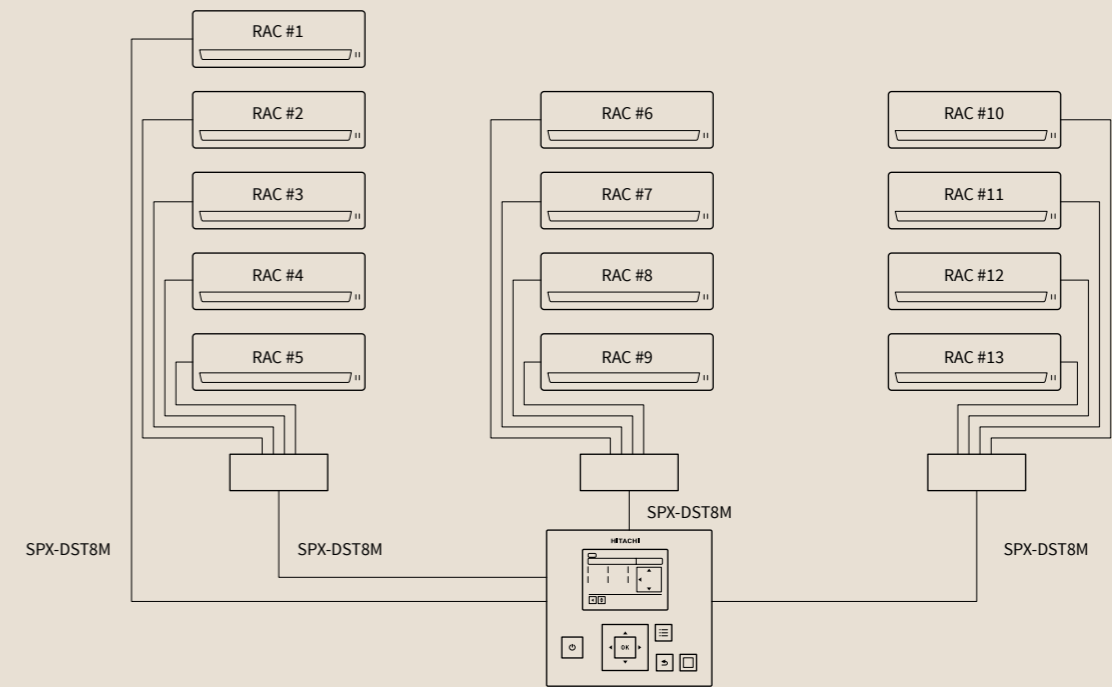

- Long pipe distances between the outdoor unit and the indoor unit. The longest on the market.
- Offset value setting from the Eco Control.
- Operation in cold mode up to -10 °C.
- Centralised control of up to 13 indoor units with the SPX-WTK3 cable control and the SPX-DST1 + SPX-DST8M distributor.

5 Low-power, high-performance systems

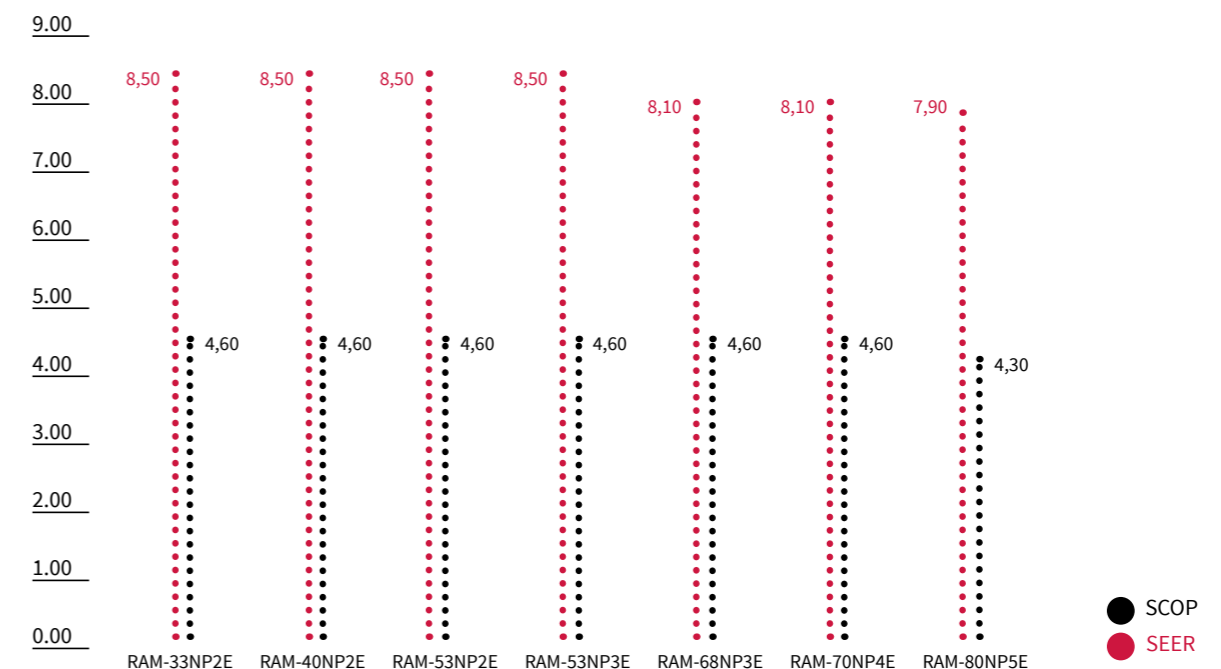

R32 Multizone

Outdoor units

Multizone

Outdoor unit		RAM-33NP2E	RAM-40NP2E	RAM-53NP2E	RAM-53NP3E	RAM-68NP3E	RAM-70NP4E	RAM-90NP5E	RAM-110NP5E
Minimum/maximum number of connectable indoor units		2	2	2	2/3	2/3	2/4	2/5	2/5
Capacity	Cooling (Min/Nom/Max) kW	1.50-3.30-3.80	1.50-4.00-4.20	1.50-5.30-6.60	1.50-5.30-6.60	2.40-6.80-8.00	2.40-7.00-8.80	1.52-8.50-9.50	1.50-10.00-12.50
	Heating (Min/Nom/Max) kW	1.50-4.00-4.60	1.50-5.20-5.50	1.50-6.80-7.20	1.50-6.80-7.20	2.40-8.50-9.50	2.60-8.50-9.50	1.50-10.00-11.50	1.50-12.00-12.70
Consumption	Cooling (Min/Nom/Max) kW	0.20-0.73-1.05	0.20-0.95-1.15	0.20-1.26-1.66	0.20-1.26-1.68	0.46-1.83-2.96	0.46-1.89-3.20	0.20-2.50-3.85	0.50-3.10-4.50
	Heating (Min/Nom/Max) kW	0.20-0.90-1.50	0.20-1.18-1.50	0.20-1.61-2.01	0.20-1.61-1.86	0.43-2.12-2.60	0.48-2.02-3.12	0.20-2.56-3.85	0.50-3.16-5.00
Electrical power		1~230V 50Hz	1~230V 50Hz	1~230V 50Hz	1~230V 50Hz	1~230V 50Hz	1~230V 50Hz	1~230V 50Hz	1~230V 50Hz
Indoor/outdoor wiring section (shielded)	mm ²	2 x (3 x 1.50 + E)	2 x (3 x 1.50 + E)	2 x (3 x 1.50 + E)	3 x (3 x 1.50 + E)	3 x (3 x 1.50 + E)	4 x (3 x 1.50 + E)	5 x (3 x 1.50 + E)	5 x (3 x 1.50 + E)
EER		4.50	4.20	4.20	4.10	3.70	3.70	3.40	3.23
COP		4.40	4.40	4.20	4.20	4.00	4.20	3.90	3.80
SEER		8.50	8.60	8.50	8.50	8.10	8.10	7.90	6.52
SCOP		4.60	4.60	4.60	4.60	4.60	4.60	4.30	4.22
Energy rating (medium zone)	Cooling/Heating	A+++/A++	A+++/A++	A+++/A++	A+++/A++	A++/A++	A++/A++	A++/A++	A++/A+
	Cooling (DB) °C	-10 to 46	-10 to 46	-10 to 46	-10 to 46	-10 to 46	-10 to 46	-10 to 46	-10 to 46
Outdoor operating temperatures	Heating (DB) °C	-15 to 24	-15 to 24	-15 to 24	-15 to 24	-15 to 24	-15 to 24	-15 to 24	-15 to 24
	Liquid-gas	inches	1/4 x 2 - 3/8 x 2	1/4 x 2 - 3/8 x 2	1/4 x 2 - 3/8 x 2	1/4 x 3 - 3/8 x 3	1/4 x 3 - 3/8 x 3	1/4 x 4 - (3/8 x 3) + (1/2 x 1)	1/4 x 5 - (3/8 x 3) + (1/2 x 2)
Air flow	Cooling m ³ /h	1,620	1,620	2,160	2,160	2,700	2,700	3,900	4,000
	Heating m ³ /h	1,620	1,620	2,160	2,160	2,700	2,700	3,900	4,000
Sound pressure	Cooling dB(A)	48	49	50	50	50	50	53	54
	Heating dB(A)	50	51	51	51	53	53	56	54
Sound power	dB(A)	60	60	60	61	63	63	66	68
N° fans		1	1	1	1	1	1	1	1
Minimum pipe length	m	3	3	3	3	3	3	3	3
Maximum pipe length	m	35	35	35	60	60	60	75	75
Maximum height difference	m	15	15	20	20	20	20	20	20
Compressor		Rotary	Rotary	New Twin Rotary	New Twin Rotary	New Twin Rotary	New Twin Rotary	New Twin Rotary	New Twin Rotary
Refrigerant		R32	R32	R32	R32	R32	R32	R32	R32
Refrigerant charge (length without additional charge)	kg (m)	1.02 (35)	1.02 (35)	1.8 (35)	2.05 (35)	2.05 (30)	2.05 (30)	2.40 (35)	2.40 (30)
Additional refrigerant charge	g/m	not required	not required	not required	20	20	20	15	13
Dimensions (H x W x D)	mm	570x750x280	570x750x280	750x850x298	800x850x298	800x850x298	800x850x298	800x950x370	800x950x370
Weight	kg	38.0	41.0	53.0	54.0	58.0	58.0	71.0	76.0



Outdoor units

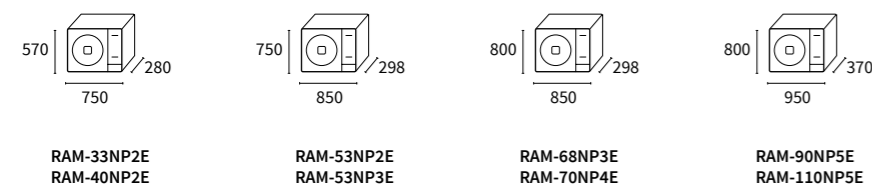

RAM-33NP2E RAM-40NP2E RAM-53NP2E RAM-53NP3E RAM-68NP3E RAM-70NP4E RAM-90NP5E RAM-110NP5E

*Residential accessories are compatible with Multizone

R32 Multizone

Indoor units

Wall-Mounted Shirokuma

Multizone

Indoor unit		RAK-18QXE**	RAK-25RXE	RAK-35RXE	RAK-50RXE
Capacity	Cooling (Min/Nom/Max) kW	1.00-1.80-2.50	0.90-2.50-3.10	0.90-3.50-4.00	1.90-5.00-5.20
	Heating (Min/Nom/Max) kW	1.10-2.50-3.20	0.90-3.20-4.20	0.90-4.00-4.80	2.20-5.80-7.00
Air flow (Very low - Low - Medium - High)	Cooling m ³ /h	300-330-430-500	300-330-510-600	320-340-520-660	350-400-580-720
	Heating m ³ /h	310-360-480-600	290-370-560-680	310-380-570-720	350-420-620-800
Sound pressure (Very low - Low - Medium - High)	Cooling dB(A)	20-25-30-36	20-27-35-43	22-29-37-45	25-31-39-47
	Heating dB(A)	20-26-32-38	20-28-36-43	22-30-37-45	25-31-39-48
Sound power	dB(A)	49	58	60	60
Pipe diameter	Liquid-gas	inches	1/4-3/8	1/4-3/8	1/4-3/8
Condensate pipe diameter (out)		mm	16	16	16
Dimensions (H x W x D)		mm	295x900x210	295x900x210	295x900x210
Weight	kg	11.0	11.0	11.0	11.0
Remote control included		Wireless - RAR-6NE1	Wireless - RAR-6NE1	Wireless - RAR-6NE1	Wireless - RAR-6NE1
Electrical power		1~230V 50Hz	1~230V 50Hz	1~230V 50Hz	1~230V 50Hz

**Data is provisional

Indoor units

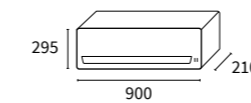

RAK-18QXE RAK-25RXE RAK-35RXE RAK-50RXE



Wall-Mounted Performance

Indoor unit		RAK-15QPE**	RAK-18RPE	RAK-25RPE	RAK-35RPE	RAK-50RPE
Capacity	Cooling (Min/Nom/Max) kW	0.90-1.50-2.00	0.90-2.00-2.50	0.90-2.50-3.10	0.90-3.50-4.00	1.90-5.00-5.20
	Heating (Min/Nom/Max) kW	1.00-1.50-2.50	0.90-2.50-3.20	0.90-3.40-4.40	0.90-4.20-5.0	2.20-6.00-7.30
Air flow (Very low - Low - Medium - High)	Cooling m ³ /h	312-350-400-420	312-350-400-440	333-370-430-510	353-420-485-680	353-410-540-750
	Heating m ³ /h	312-350-420-480	312-350-420-480	333-400-500-570	363-480-570-780	380-500-610-820
Sound pressure (Very low - Low - Medium - High)	Cooling dB(A)	20-24-30-34	21-24-33-37	22-24-33-40	25-26-36-43	25-28-39-46
	Heating dB(A)	20-24-32-35	19-22-33-38	20-23-34-41	26-27-36-44	27-31-39-46
Sound power	dB(A)	47	51	54	57	60
Pipe diameter	Liquid-gas	inches	1/4-3/8	1/4-3/8	1/4-3/8	1/4-3/8
Condensate pipe diameter (out)		mm	16	16	16	16
Dimensions (H x W x D)		mm	280x780x230	280x780x230	280x780x230	280x780x230
Weight	kg	8.5	8.5	8.5	8.5	8.5
Remote control included		Wireless - RAR-6NE1	Wireless - RAR-6NE1	Wireless - RAR-6NE1	Wireless - RAR-6NE1	Wireless - RAR-6NE1
Electrical power		1~230V 50Hz	1~230V 50Hz	1~230V 50Hz	1~230V 50Hz	1~230V 50Hz

**Data is provisional

Indoor units

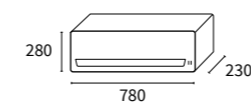

RAK-15QPE RAK-18RPE RAK-25RPE RAK-35RPE RAK-50RPE



*Residential accessories are compatible with Multizone

R32 Multizone

Indoor units

Multizone

Shirokuma Console

Indoor unit			RAF-25RXE	RAF-35RXE	RAF-50RXE
Capacity	Cooling (Min/Nom/Max)	kW	0.90-2.50-3.10	0.90-3.50-4.00	0.90-5.00-5.20
	Heating (Min/Nom/Max)	kW	0.90-3.40-4.40	0.90-4.50-5.00	0.90-6.00-8.10
Air flow (Very low - Low - Medium - High)	Cooling	m3/h	270-390-510-630	270-390-510-660	300-450-540-700
	Heating	m3/h	300-420-540-660	300-420-540-690	330-480-570-730
Sound pressure (Very low - Low - Medium - High)	Cooling	dB(A)	20-26-31-38	20-26-31-39	22-29-36-43
	Heating	dB(A)	20-26-31-38	20-26-31-39	22-29-36-44
Sound power		dB(A)	52	53	57
Pipe diameter	Liquid-gas	inches	1/4-3/8	1/4-3/8	1/4-1/2
Condensate pipe diameter (out)		mm	16	16	16
Dimensions (H x W x D)		mm	590x750x215	590x750x215	590x750x215
Weight		kg	15.0	15.0	15.0
Remote control included			Wireless - RAR-6NE4	Wireless - RAR-6NE4	Wireless - RAR-6NE4
Electrical power			1 ~230V 50Hz	1 ~230V 50Hz	1 ~230V 50Hz

Indoor units

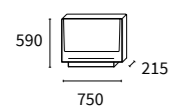

RAF-25RXE
RAF-35RXE
RAF-50RXE



*Residential accessories are compatible with Multizone

Ducts

Indoor unit			RAD-18QPE	RAD-25RPE	RAD-35RPE	RAD-50RPE	RAD-60RPE
Capacity	Cooling (Min/Nom/Max)	kW	0.90-1.80-2.50	0.90-2.50-3.00	0.90-3.50-4.00	1.20-5.00-5.80	1.20-6.00-6.50
	Heating (Min/Nom/Max)	kW	0.90-2.50-3.20	0.90-3.50-5.50	0.90-4.80-6.60	1.20-6.00-6.80	1.20-7.00-8.00
Air flow (Very low - Low - Medium - High)	Cooling	m3/h	330-390-450-510	330-390-450-510	330-390-450-510	350-540-800-1,140	350-540-800-1,140
	Heating	m3/h	330-390-450-510	330-390-450-510	330-390-450-510	350-540-800-1,140	350-540-800-1,140
Sound pressure (Very low - Low - Medium - High)	Cooling	dB(A)	30-33-37-41	30-33-37-41	30-33-37-41	29-32-35-39	29-32-35-39
	Heating	dB(A)	30-34-38-42	30-34-38-42	30-34-38-42	29-32-35-40	29-32-35-40
Sound power		dB(A)	57	57	57	53	53
Available pressure (Low - Medium - High)		Pa	70	70	70	50-100-150	50-100-150
Pipe diameter	Liquid-gas	inches	1/4-3/8	1/4-3/8	1/4-3/8	1/4-1/2	1/4-1/2
Condensate pipe diameter (out)		mm	16	16	16	32	32
Dimensions (H x W x D)		mm	235x750x400	235x750x400	235x750x400	270x900x720	270x900x720
Weight		kg	16.0	16.0	16.0	35.0	35.0
Condensate pump			Included	Included	Included	Included	Included
Electrical power			1 ~230V 50Hz	1 ~230V 50Hz	1 ~230V 50Hz	1 ~230V 50Hz	1 ~230V 50Hz

Indoor units

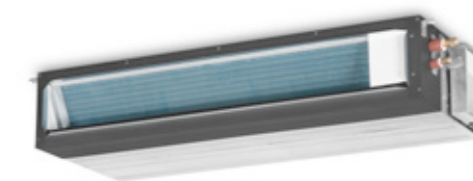
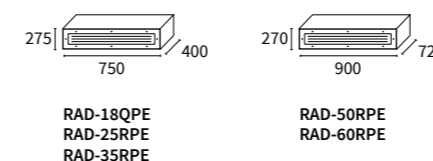

Cassette

Indoor unit			RAI-25RPE	RAI-35RPE	RAI-50RPE	RAI-60RPE
Capacity	Cooling (Min/Nom/Max)	kW	0.90-2.50-3.00	0.90-3.50-4.00	1.20-5.00-5.80	1.20-6.00-6.50
	Heating (Min/Nom/Max)	kW	0.90-3.50-5.00	0.90-4.80-6.60	1.20-6.00-6.80	1.20-7.00-8.00
Air flow (Very low - Low - Medium - High)	Cooling	m3/h	360-505-590-660	360-505-590-660	390-540-630-720	390-540-630-720
	Heating	m3/h	444-540-630-720	444-540-630-720	450-600-690-780	450-600-690-780
Sound pressure (Very low - Low - Medium - High)	Cooling	dB(A)	27-31-35-38	27-33-37-40	29-35-39-43	29-35-39-43
	Heating	dB(A)	28-32-36-39	28-34-38-41	30-36-40-44	30-36-40-44
Sound power		dB(A)	54	56	56	56
Pipe diameter	Liquid-gas	inches	1/4-3/8	1/4-3/8	1/4-1/2	1/4-1/2
Condensate pipe diameter (out)		mm	32	32	32	32
Cassette dimensions (H x W x D)		mm	285x570x570	285x570x570	285x570x570	285x570x570
Cassette weight		kg	17	17	17	17
Panel dimensions (H x W x D)		mm	30x620x620	30x620x620	30x620x620	30x620x620
Panel weight		kg	2.8	2.8	2.8	2.8
Condensate pump			Included	Included	Included	Included
Electrical power			1 ~230V 50Hz	1 ~230V 50Hz	1 ~230V 50Hz	1 ~230V 50Hz

Indoor units

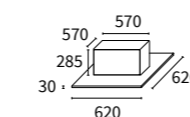

RAI-25RPE RAI-50RPE
RAI-35RPE RAI-60RPE



*Residential accessories are compatible with Multizone

Multizone

When you're considering the ideal solution for business facilities (from small businesses or premises at street level, through to large commercial offices), think of Hitachi VRF systems.

These systems allow connection to up to 64 indoor units, each with their own individual control. There is also a large range of options to match the requirements you define for each installation such as wall mounts, cassettes, ducts and hydro modules as well as a huge range of control options.

Café Comercial in Madrid, air conditioned with the VRF range



VRF Systems







Quick selection table

VRF Systems









In your day to day life you have to make many decisions. To help with your workload we offer you the quick selection guide. Just follow the following 4 steps for a seamless design selection.

VRF Systems



VRF Systems

Outdoor units	2 SELECT POWER Nominal cooling powers (kW)																			3 REVIEW YOUR NEEDS								4 CHOOSE INDOOR UNITS					
	5	5.6	7.1	10	11.2	12.5	14	15.5	16	20	22.4	24	25	28	30	33.5	40	45	50	56	61.5	67	>100	Max n° indoor units	Maximum pipe length (actual)	Maximum pipe length (equivalent)	Type of fan		Available static pressure	Independent control of indoor units	Centralised control	Energy efficiency level	Different types for flexibility
VRF IXV 	•	•	•	•		•	•		•			•		•											Up to 4	Up to 100 m	Up to 125 m	Axial horizontal discharge	No	Yes	Yes, H-Link bus	+++	From 1.7 to 56 kW
VRF IXV Centrifugal 				•		•	•		•		•														Up to 6	Up to 100 m	Up to 125 m	Centrifugal	from 100 Pa to 120 Pa	Yes	Yes, H-Link bus	+++	Wall-mounted
VRF Set Free Mini 					•		•	•		•			•												Up to 39	Up to 125 m	Up to 150 m	Axial horizontal discharge	up to 30 Pa	Yes	Yes, H-Link bus	++++	Ducts
VRF Set Free Sigma Standard 											•		•		•	•	•	•	•	•	•	•	•	•	Up to 64	Up to 165 m	Up to 190 m	Axial vertical discharge	Up to 50 Pa	Yes	Yes, H-Link bus	+++++	Cassettes
VRF Set Free Sigma High-Efficiency 							•	•		•		•		•	•	•	•	•	•	•	•	•	•	•	Up to 64	Up to 165 m	Up to 190 m	Axial vertical discharge	Up to 50 Pa	Yes	Yes, H-Link bus	+++++	Ceiling-mounted

CONTROLS

Individual			Centralised					
								
PC-ARFP1E	PC-AWR	PC-AWH	PSC-A16RS	PSC-A64S	PSC-A1T	CS-NET WEB MANAGER	PSC-A32MN	PSC-A64GT

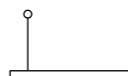
COMMUNICATION PROTOCOLS

		
MODBUS	BACNET	KNX

VRF IVX

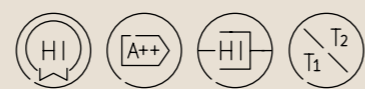

- VRF simplified alternative at a competitive price for small commercial applications.
- With independent control for up to four rooms, allowing temperatures to be selected for different spaces and times and with varying fan speeds.
- Ideal for: small- and medium-sized businesses.

VRF IVX Centrifugal

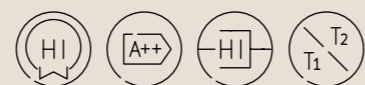

- Perfect for conditioning high street premises thanks to its being hidden away within the building facade (false ceiling).
- Can be used to connect up to 6 indoor units, achieving greater savings and comfort thanks to independent temperature control.
- Ideal for: restaurants, dental clinics, offices, shops, commercial businesses, etc.

VRF Set Free Mini

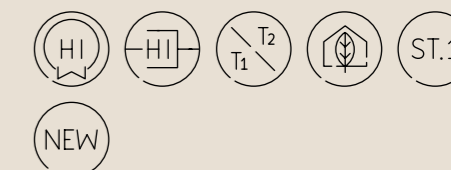

- The only 3 pipe heat recovery sideflow VRF on the market for horsepowers 8 to 12.
- Can now achieve world leading efficiencies with a much smaller footprint and gas charge.
- Wide choice of indoor units available with Hitachi exclusive 0.4 hp for maximum flexibility.
- Connect up to 39 indoor units
- 30 Pa of pressure available for the ultimate discrete installation.
- Ideal for hotels, small medium and large commercial applications.

VRF Set Free Sigma

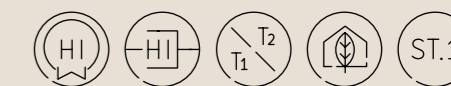

- New VRF Set Free Sigma Standard and High-Efficiency range: the most flexible 2- and 3-pipe VRF on the market. Flexible design with modular combinations up to 268.80 kW (96 HP). With individual modules up to 67.20 kW (24 HP), ensuring space and cost savings when roof space is limited. Extension of cooling operation from 43°C to 48°C in the standard range, and 52°C in the high-efficiency range.
- Ideal for: hotels, restaurants, office buildings, gyms, etc.

Benefits VRF IVX

1 The smallest mini VRF on the market, in the most extensive range of its category.



The Premium version of Hitachi's VRF IVX is the smallest VRF on the market. The range starts at just 5 kW cooling capacity, reaching 30 kW in its highest power model. Japanese VRF technology that adapts to the needs of all your projects, regardless of the space available.

2 Compact units, more free space in buildings.

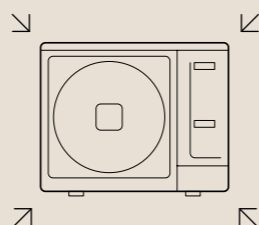

The VRF IVX Comfort range is so compact that it can deliver 14 kW of power (6HP) with a single fan, and takes up just 0.35m² of floorspace.

3 Customised businesses with independent temperatures in each zone.

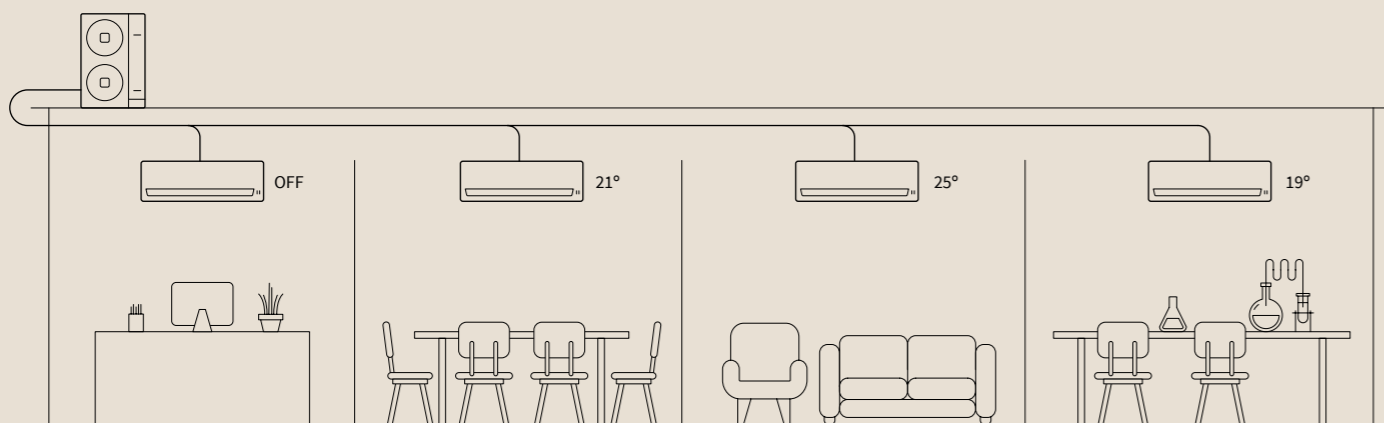

Air-conditioning requirements vary greatly within the same premises, depending, for example, on the activity being carried out in the different rooms, their orientation or the number of windows. Hitachi's VRF IVX range ensures maximum comfort in all zones, since their temperature can be chosen individually.

VRF IVX units are ideal for small- and medium-sized businesses, as up to 8 spaces can be conditioned at different temperatures using a single outdoor unit.

4 Flexibility in the choice of indoor units



The aesthetic or space requirements differ from room to room within the same premises. The VRF System Free range of indoor units ensures this is not a problem, as all indoor units are compatible with the VRF IVX range, and can be mixed and matched as required (with wall-mounting, duct, cassette, console, ceiling-mounting or DX Kit units).

7 Smart defrost control. More comfort in winter with improved energy efficiency

The VRF IVX range has two interesting functions to reduce the number of defrosts and ensure high performance during extreme temperatures in winter.

The system carries out "smart defrosting" by adjusting defrosting time in accordance with the time required in the previous cycle, thus extending heating operation and avoiding any problems in terms of comfort indoors.

It also counts on hot gas injection in the coil as standard, preventing ice from forming in the coil and, in consequence, removing the need to defrost.

5 Easy installation of the refrigerant piping

VRF IVX units are easier to install than other "multi" types on the market. The refrigerant piping is in a single line with the same diameter throughout the main section using splitters to connect to the different indoor units, each with their own pipe sizes. This reduces the amount of refrigerant piping, reducing installation costs and saving your valuable time.

6 Wide range of cooling distances

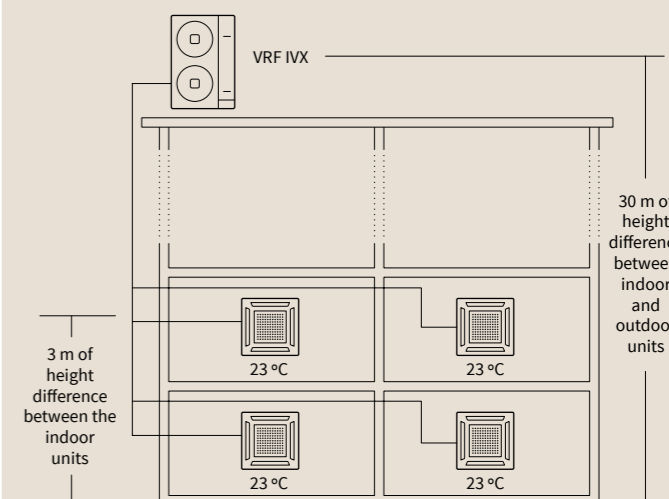

Example of a building conditioned with VRF IVX

The VRF IVX units have a total pipe run of up to 100 m, and a height difference of 30 m between the indoor and outdoor units. This makes it much easier to place the outdoor unit in a suitable location (e.g. on the roof of the building) without interfering with the aesthetics of the premises.

It is also possible to install indoor units on different floors connected to the same cooling line. Commercial premises with up to 2 floors can therefore be conditioned with a single outdoor unit.

VRF IXV

Competitively priced VRF technology for small commercial applications

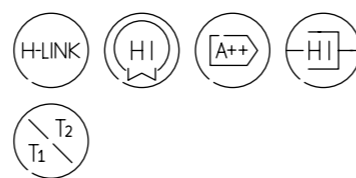
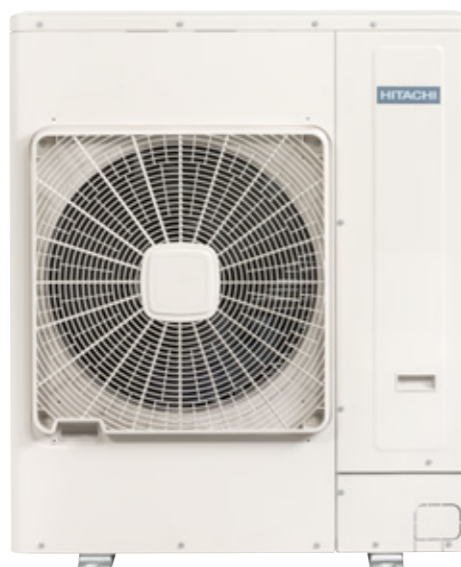

Independent control

Independent operation of up to 4 indoor units. A different type of indoor unit, each with its own control and temperature, can be installed in each room. Furthermore, it is also possible to use the same control for several indoor units working independently of each other.

(Fig. 1)

Wide range of lengths

Up to 100m of refrigerant pipe run and 30m of height difference between indoor units.

(Fig. 2)

Improved performance

Operation at extreme temperatures. The best performance even at extreme temperatures, -20°C in heating and 46°C in cooling.

Compact unit

Up to 14 kW (6 HP) with a single fan; 0.35 m² of floorspace.

Flexibility

Compatible with the entire range of System Free indoor units. H-link communication protocol which can be managed via all control systems; individual and/or centralised.

Easy to install

Installation is made simple thanks to a single piping line common for all 4 indoor units.

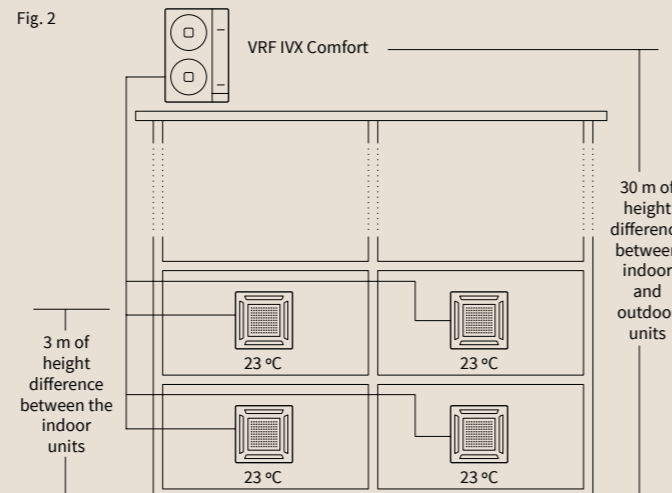
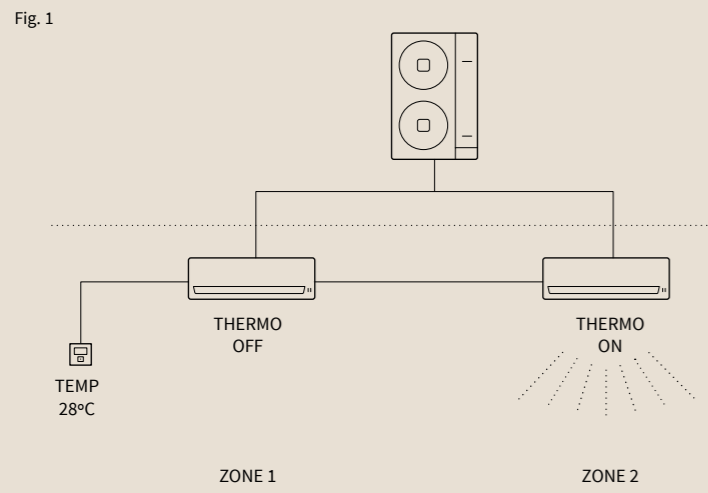

Outdoor units

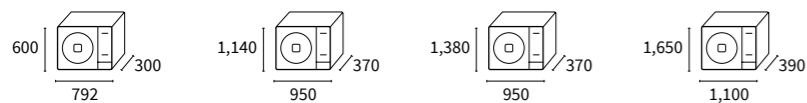

RAS-2HVNP1
 RAS-2.5HVNP1
 RAS-3HVNC1

RAS-4H(V)NC1E
 RAS-5H(V)NC1E
 RAS-6H(V)NC1E

RAS-8HNCE
 RAS-10HNCE

RAS-12HNC

VRF IXV

Outdoor unit			RAS-2HVNP1	RAS-2.5HVNP1	RAS-3HVNC1	RAS-4H(V)NC1E	RAS-5H(V)NC1E	RAS-6H(V)NC1E	RAS-8HNCE	RAS-10HNCE	RAS-12HNC
Maximum number of connectable indoor units			2	2	2	4	4	4	4	4	4
Capacity index *	%		90-110	90-110	90-100	90-115	90-115	90-115	90-115	90-115	90-115
Capacity	Cooling (Min/Nom/Max)	kW	2.20-5.00-5.60	2.20-5.60-6.30	3.20-7.10-8.00	4.50-10.00-11.20	5.70-12.50-14.00	6.00-14.00-16.00	8.00-20.00-22.40	10.00-25.00-28.00	11.20-30.00-33.50
	Heating (Min/Nom/Max)	kW	2.20-5.60-7.01	2.20-6.30-8.00	3.50-8.00-10.60	5.00-11.20-14.00	5.00-14.00-18.00	5.00-16.00-20.00	6.30-22.40-28.00	8.00-28.00-35.00	9.00-33.50-37.50
Consumption	Cooling (Nom)	kW	1.24	1.34	2.26	2.70	3.71	4.29	5.95	8.28	11.67
	Heating (Nom)	kW	1.20	1.28	2.00	2.45	3.60	3.78	5.88	7.71	13.04
EER			4.03	4.18	3.14	3.70	3.37	3.26	3.36	3.02	2.57
COP			4.68	4.92	4.00	4.57	3.89	4.23	3.81	3.63	2.57
SEER	Single-phase		6.49	6.05	6.00	6.57	6.10	5.88	-	-	-
	Three-phase		-	-	-	6.41	6.06	5.85	6.79	6.61	5.30
SCOP	Single-phase		4.67	4.77	4.21	4.47	4.00	4.05	-	-	-
	Three-phase		-	-	-	4.47	4.00	4.05	4.19	3.79	3.66
Energy rating (medium zone)	Cooling/Heating		A+/A++	A+/A++	A+/A+	A+/A+	-	-	-	-	-
Electrical power			1 ~230V 50Hz	1 ~230V 50Hz	1 ~230V 50Hz	1 ~230V 50Hz	1 ~230V 50Hz	1 ~230V 50Hz	-	-	-
			-	-	-	3N ~400V 50 Hz	3N ~400V 50 Hz	3N ~400V 50 Hz	3N ~400V 50 Hz	3N ~400V 50 Hz	3N ~400V 50 Hz
Maximum current	Single-phase	A	13.8	15.8	17.8	15.5	15.0	15.5	-	-	-
	Three-phase	A	-	-	-	28.5	28.0	28.5	24.0	24.0	24.0
Indoor/outdoor wiring section (shielded)		mm	2x0.75	2x0.75	2x0.75	2x0.75	2x0.75	2x0.75	2x0.75	2x0.75	2x0.75
Outside operating temperatures	Cooling (DB)	°C	-5 to 46	-5 to 46	-5 to 46	-5 to 46	-5 to 46	-5 to 46	-5 to 46	-5 to 46	-5 to 46
	Heating (WB)	°C	-20 to 15	-20 to 15	-20 to 15	-20 to 15	-20 to 15	-20 to 15	-20 to 15	-20 to 15	-20 to 15
Air flow		m ³ /h	2,436	2,436	2,682	3,720	4,080	4,800	7,620	8,040	9,780
Sound pressure	Cooling	dB(A)	44	45	48	52	52	55	57	58	59
	Heating	dB(A)	46	47	50	54	54	57	59	60	61
Sound power		dB(A)	62	63	66	68	69	71	76	76	77
N° fans			1	1	1	1	1	1	2	2	2
Pipe diameter	Liquid-gas	inches	1/4-1/2	1/4-1/2	3/8-5/8	3/8-5/8	3/8-5/8	3/8-5/8	3/8-1	1/2-1	1/2-1
Minimum pipe length		m	5	5	5	5	5	5	5	5	5
Maximum pipe length		m	50	50	50	70	75	75	100	100	100
Maximum height difference (highest OU/lowest OU)		m	30/20	30/20	30/20	30/20	30/20	30/20	30/20	30/20	30/20
Compressor			Scroll DC Inverter	Scroll DC Inverter	Scroll DC Inverter	Scroll DC Inverter	Scroll DC Inverter	Scroll DC Inverter	Scroll DC Inverter	Scroll DC Inverter	Scroll DC Inverter
Refrigerant			R-410A	R-410A	R-410A	R-410A	R-410A	R-410A	R-410A	R-410A	R-410A
Refrigerant charge (length without additional charge)		kg (m)	1.6 (30)	1.6 (30**)	1.9 (20)	3.2 (30)	3.2 (30)	3.2 (30)	5.7 (30)	6.2 (30)	6.7 (30)
Additional refrigerant charge		g/m	30	30	40	40	60	60	must be calculated	must be calculated	must be calculated
Dimensions (H x W x D)		mm	600x792x300	600x792x300	600x792x300	1,140x950x370	1,140x950x370	1,140x950x370	1,380x950x370	1,380x950x370	1,650x1,100x390
Weight		kg	43.0	43.0	44.0	79.0	89.0	89.0	136.0	138.0	168.0

*Ask about limitations on combining some indoor units.

Compatible controls and accessories:

- DBSS26 Drain pipe connection kit
- DBS-26
- Compatible with RAS 3-12 H(V)NCE

Combinations table

Outdoor unit	2 HP ¹	2.5 HP ²	3 HP	4HP	5HP	6HP	8HP	10HP	12HP
Maximum number of indoor units connected	2	2	2	4	4	4	4	4	4
Ratio of indoor units connected % (number of indoor units connected)	90 - 110 % (1 unit)	90 - 110 % (1 unit)	90 - 110 % (1 unit)	90 - 115 % (≤ 2 units)	90 - 115 % (≤ 2 units)	90 - 115 % (≤ 2 units)	90 - 115%	90 - 115%	90 - 115%
Minimum connectable indoor unit (HP)	0.8	0.8	0.8	0.8	0.8	0.8	1.8	1.8	1.8

(1) Only the 1x1 combination is allowed when installing RCI-FSN4 indoor units.
 (2) If multiple indoor units are installed or there is an RCI-FSN4 unit, the minimum capacity allowed for these series is 1.5 HP.

– The RPI-8FSN3E and RPI-10.0FSN3E units can only be installed in 1x1 combination. For different combinations, please contact your usual Hitachi vendor.
 – In systems where all units are RCI-FSN4, the maximum allowable capacity ratio is 100% and the maximum number of connectable indoor units is as follows: 2 and 2.5 HP: 1 unit, 3 HP: 2 units, 4, 5, 6, 8, 10 and 12 HP: 4 units.

Combinations

RAS 2-2.5 HVNP(1) *90 - 110%

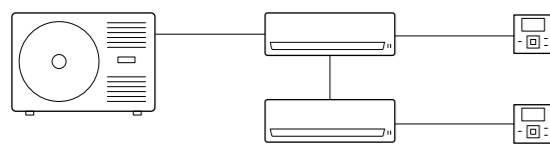

RAS - 3H(V)NC1 *90-110%

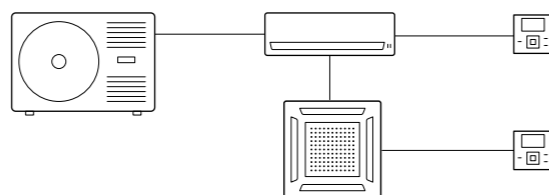

RAS - 4-6H(V)NC1E *90-115%

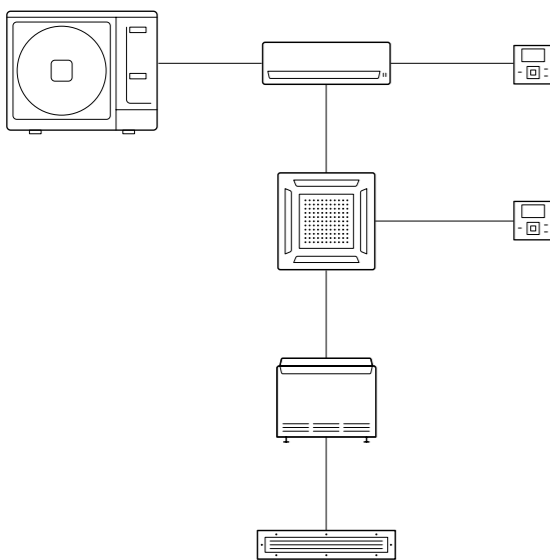

RAS - 8~12HNC(E) *90-115%

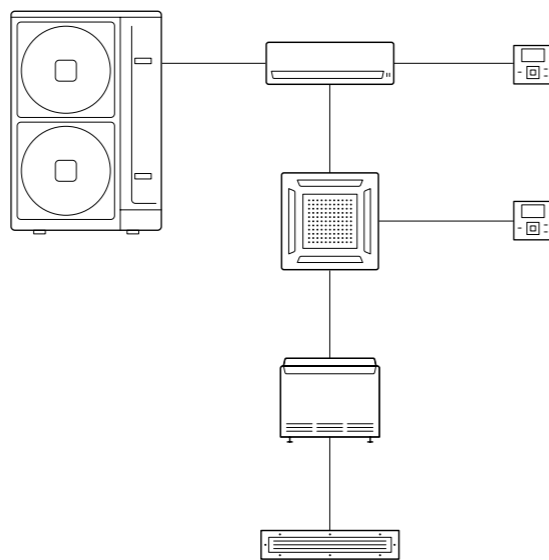

*See the combinations table for more information.

Maximum length of refrigerant pipes (in-line distribution)

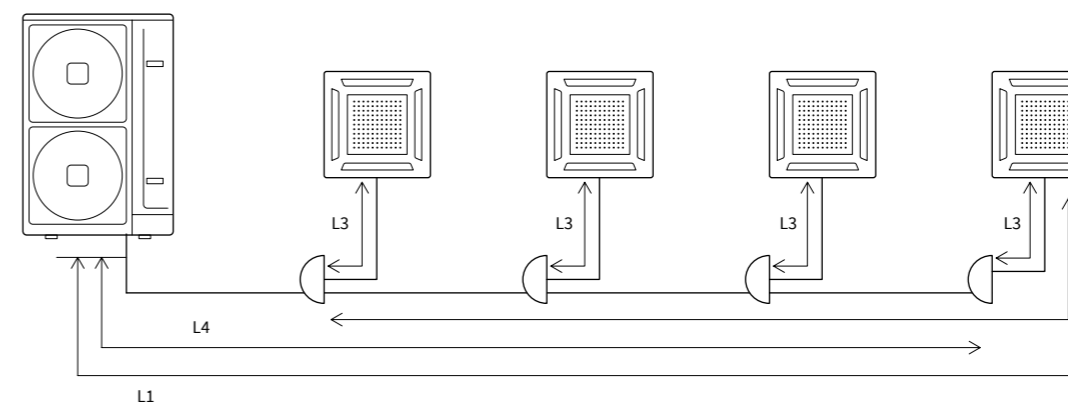

Indoor unit		4 HP	5 HP	6 HP	8 HP	10 HP	12 HP
Maximum pipe length between the outdoor unit and the furthest indoor unit	Actual length (L1)	m	70	75	75	100	100
	Equivalent length	m	90	95	95	125	125
Maximum length from first branch to each indoor unit (L2)		m	20	20	20	25	25
Maximum pipe length from indoor unit splitter (L3)		m	10	10	10	15	15
Total pipe length L4 + (L3 + L3 + L3...)		m	70	75	75	100	145
Maximum height difference between outdoor unit and indoor units/ If the indoor unit is higher than the outdoor unit		m	30/20	30/20	30/20	30/20	30/20
Maximum height difference between indoor units		m	3	3	3	3	3
Maximum height difference. Branch pipe/indoor		m	3	3	3	3	3
Maximum height difference. Branch pipe/outdoor		m	3	3	3	3	3

– For distributions other than in-line with splitters, please contact your usual Hitachi vendor.

Pipe and splitter dimensions

Main pipe dimensions

	Liquid	Gas
RAS - 3HVNC1	3/8"	5/8"
RAS - 4 H(V)NC1E	3/8"	5/8"
RAS - 5H(V)NC1E	3/8"	5/8"
RAS - 6 H(V)NC1E	3/8"	5/8"
RAS - 8HNCE	3/8"	1"
RAS - 10HNCE	1/2"	1"
RAS - 12HNCE	1/2"	1"

Dimensions between the splitter and the indoor unit

		Pipe size	
		Liquid	Gas
Indoor unit	≤ 1.50 HP	1/4"	1/2"
	1.80 - 2.00 HP	1/4"	5/8"
	≥ 2.30 HP	3/8"	5/8"

Splitters

Outdoor unit	Multi-kit
RAS - 3HVNC1	E-102SN4
RAS - 4 H(V)NC1E	E-102SN4
RAS - 5H(V)NC1E	E-102SN4
RAS - 6 H(V)NC1E	E-102SN4
RAS - 8HNCE	E-162SN4
RAS - 10HNCE	E-162SN4
RAS - 12HNCE	E-162SN4

Multi-kit: Splitters
E-102SN4
E-162SN4

VRF IXV Centrifugal

Hidden air conditioning for high street premises

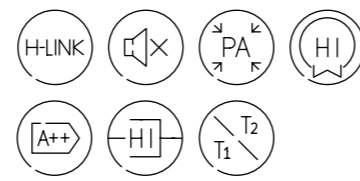

Complying with regulations

The Hitachi VRF IXV Centrifugal system meets all air discharge regulations for air conditioning, as the air flow does not exceed 3,600 m³ (depending on model).

Guaranteed comfort and savings

It conditions up to 6 different zones and ensures greater comfort and savings thanks to independent control of each indoor unit.

Designed for every need

The air input and output grilles are interchangeable, increasing the options for installation anywhere in the premises.

Greater flexibility

This system allows a connection ratio between 75% and 120%. IXV VRF Centrifugal has Eurovent-certified EER and COP, and also complies with the ErP Lot 21 Ecodesign Directive, offering high seasonal energy efficiency values certified by EUROVENT: SEER/SCOP.

Lower bills and ultraquiet operation

It is fitted with the Premium Inverter Compressor for smart defrosting and a fan regulated by a variable speed drive. Thanks to this, it significantly reduces energy consumption, extends the working life of motors operating at reduced speed, and, above all, achieves an unrivalled noise level without any vibration.

Adjustable

The IXV VRF Centrifugal's variable speed drive adjusts speed in line with requirements and keeps motor consumption to a minimum.

Control systems

Compatible with any Hitachi control systems, BMS systems and Modbus protocols, KNX.

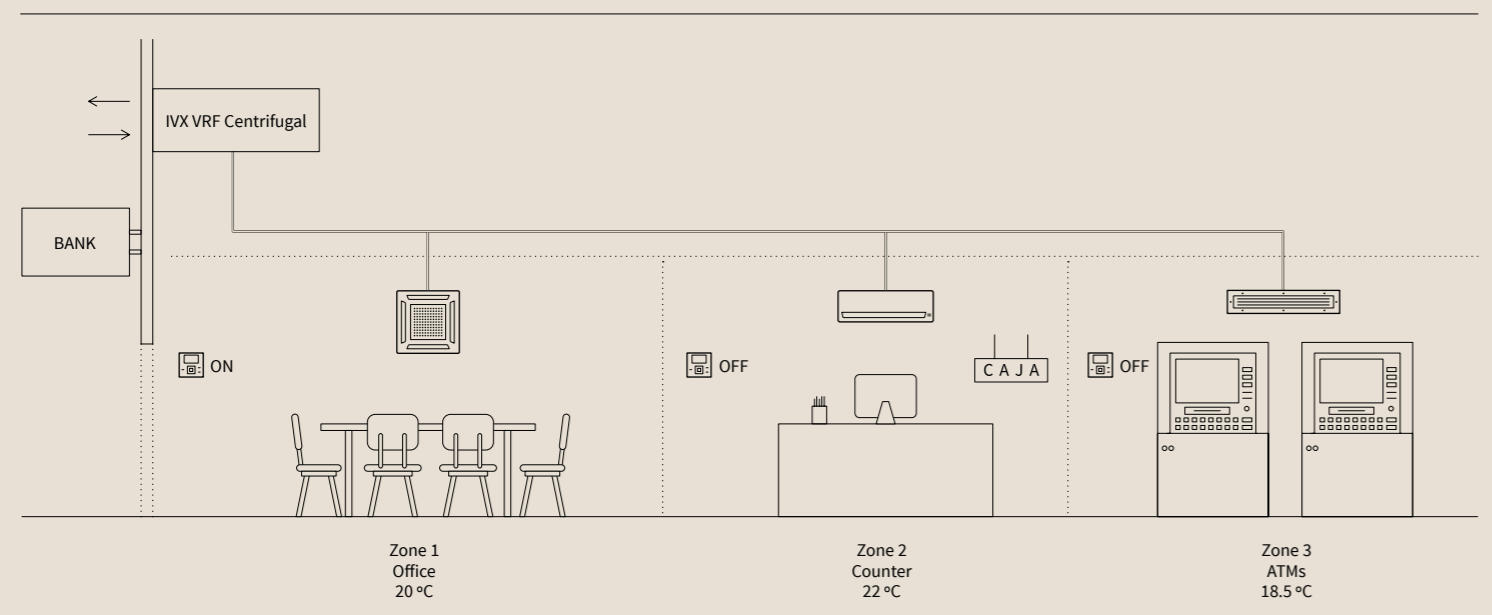

Outdoor units



RASC-4HNPE
RASC-5HNPE
RASC-6HNPE

RASC-8HNPE
RASC-10HNPE

VRF IXV Centrifugal

Outdoor unit			RASC-4HNPE	RASC-5HNPE	RASC-6HNPE	RASC-8HNPE	RASC-10HNPE
Maximum number of connectable indoor units			5	5	5	6	6
Capacity index *			75-120	75-120	75-120	75-120	75-120
Capacity	Cooling (Nom/Max)	kW	10.20-11.20	12.50-14.00	14.00-16.00	20.00-22.40	24.00-26.00
	Heating (Nom/Max)	kW	11.20-13.60	14.00-14.90	15.50-16.80	22.40-25.30	26.00-27.40
Consumption	Cooling (Nom)	kW	2.99	3.98	5.09	7.41	9.02
	Heating (Nom)	kW	2.95	4.12	5.74	7.00	8.52
EER			3.35	3.14	2.75	2.70	2.66
COP			3.80	3.40	2.70	3.20	3.05
SEER			5.60	5.43	5.22	5.39	5.48
SCOP			3.98	3.74	3.66	3.51	3.71
Outside operating temperatures	Cooling (DB)	°C	-5 to 46	-5 to 46	-5 to 46	-5 to 46	-5 to 46
	Heating (WB)	°C	-15 to 15.5	-15 to 15.5	-15 to 15.5	-15 to 15.5	-15 to 15.5
Electrical power			3N ~400V 50 Hz	3N ~400V 50 Hz	3N ~400V 50 Hz	3N ~400V 50 Hz	3N ~400V 50 Hz
Maximum current			A	14.1	14.1	16	24.7
Indoor/outdoor wiring section (shielded)			mm	2x0.75	2x0.75	2x0.75	2x0.75
Air flow			m ³ /h	3,300	3,600	3,600	6,900
Sound pressure			dB(A)	53	53	54	56
Sound power			dB(A)	70	71	72	74
Available static pressure (Nom/Max)			Pa	56/90	72/100	100/100	84/120
Pipe diameter			Liquid-gas	inches	3/8-5/8	3/8-5/8	3/8-1
Minimum pipe length			m	5	5	5	5
Maximum pipe length			m	75	75	75	100
Maximum height difference (highest OU/lowest OU)			m	30/20	30/20	30/20	30/20
Compressor				Scroll DC Inverter	Scroll DC Inverter	Scroll DC Inverter	Scroll DC Inverter
Refrigerant				R410A	R410A	R410A	R410A
Refrigerant charge (length without additional charge)			kg (m)	4.1 (30)	4.2 (30)	4.2 (30)	5.7 (30)
Additional refrigerant charge			g/m	60	60	60	Must be calculated
Dimensions (H x W x D)			mm	555x1,415x1,015	555x1,415x1,015	555x1,415x1,015	620x1,850x1,360
Weight			kg	192	192	192	300

*Ask about limitations on combining some indoor units.

Compatible controls and accessories:

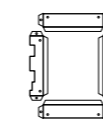

Accessory kit to change air discharge nozzle position, mod. FL-RASC46

FD-RASC46

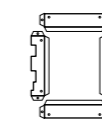

Accessory kit to change air discharge nozzle position, mod. FL-RASC810

FD-RASC810

Combinability

Outdoor unit	RASC - 4HNPE	RASC - 5HNPE	RASC - 6HNPE	RASC - 8HNPE	RASC - 10HNPE
Maximum number of indoor units connected	5	5	5	6	6
Ratio of indoor units connected % (number of indoor units connected)	75 - 120 % (≤ 4 units)	75 - 120 % (≤ 4 units)	75 - 120 % (≤ 4 units)	75 - 120 % (≤ 4 units)	75 - 120 % (≤ 4 units)
	75 - 100 % (5 units)	75 - 100 % (5 units)	75 - 100 % (5 units)	75 - 100 % (5 or 6 units)	75 - 100 % (5 or 6 units)
Minimum connectable indoor unit	0.8 (≤ 4 units: no restrictions)	0.8 (≤ 4 units: no restrictions)	0.8 (≤ 4 units: no restrictions)	0.8 (≤ 4 units: no restrictions)	0.8 (≤ 4 units: no restrictions)
	0.8 (5 units: with restrictions)	0.8 (5 units: with restrictions)	0.8 (5 units: with restrictions)	0.8 (5 units: with restrictions)	0.8 (5 units: with restrictions)

- In systems where all units are RCI-FSN4, the maximum allowable capacity ratio is 100 % and the maximum number of connectable indoor units is 4.

- The RPI-8FSN3E and RPI-10.0FSN3E units have the following combination limitations.
- The units can only be installed in 1x1 combination. There are special combinations allowed (see table below).

Special combinations allowed

The combinations allowed with RPI-8FSN3E and RPI-10.0FSN3E units are as follows:

Two indoor units system	Three indoor units system
8.0 + 3.0	8.0 + 2.0 + 2.0
8.0 + 2.0	8.0 + 1.5 + 1.5
10.0 + 3.0	8.0 + 1.0 + 1.0
10.0 + 2.0	10 + 1.5 + 1.5
	10 + 1.0 + 1.0

Combinations

RASC - 4-6HNPE

75 - 120%

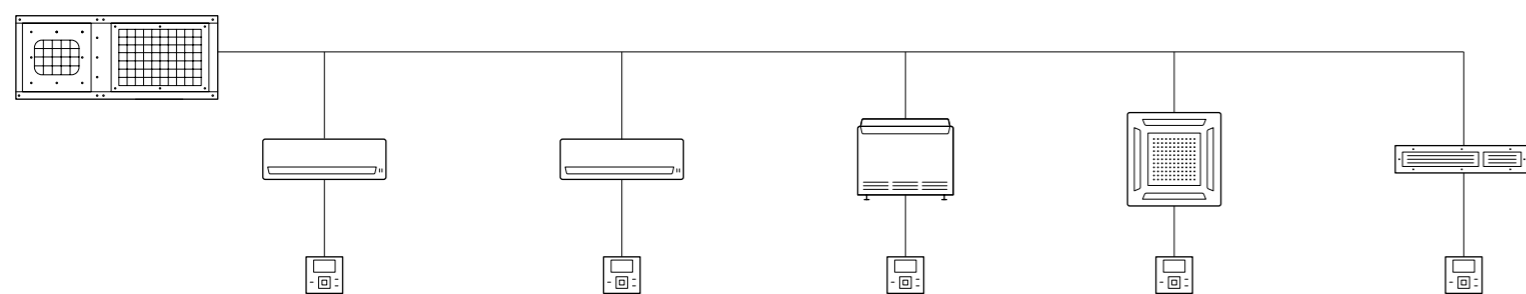

RASC - 8-10HNPE

75 - 120%

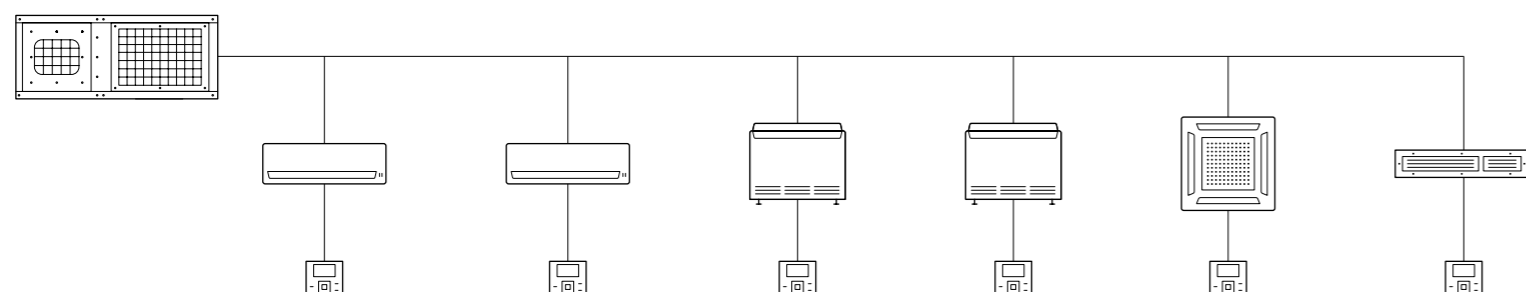

Maximum length of refrigerant pipes (in-line distribution)

Combinations

RASC-4-10HNPE

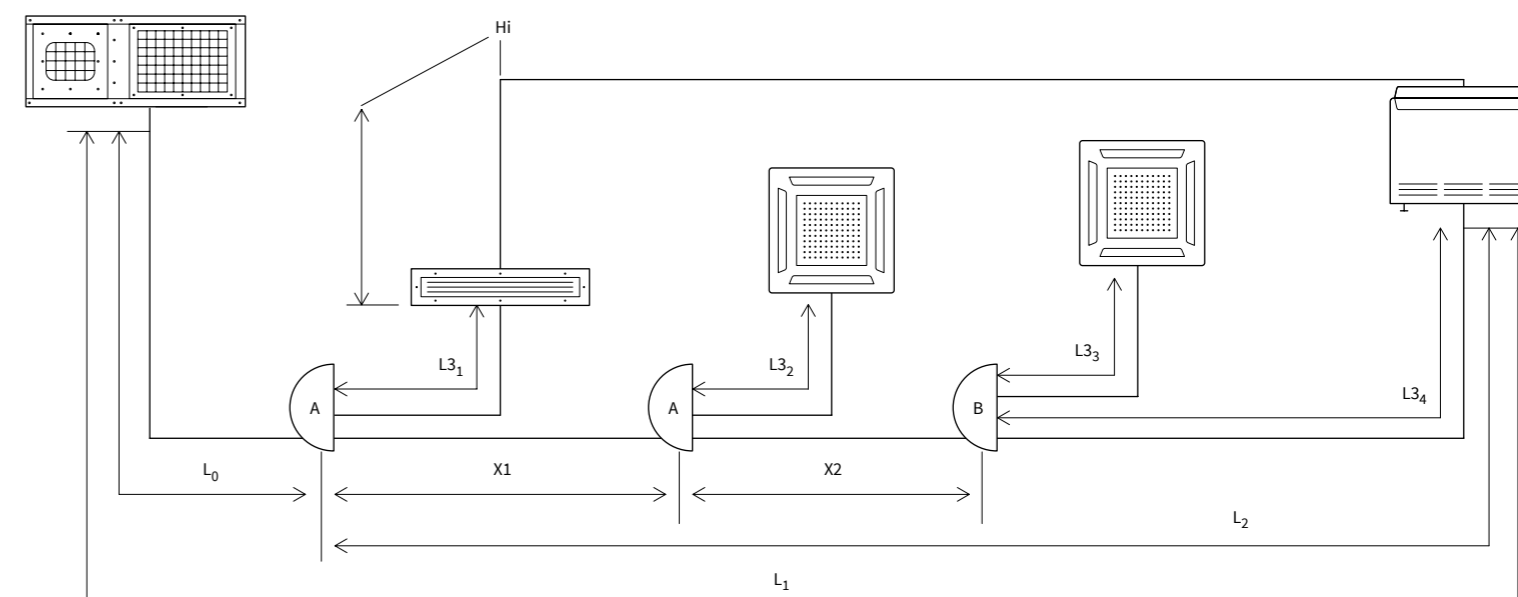

			4 HP	5 HP	6 HP	8 HP	10 HP
Maximum pipe length between the RASC unit and the furthest indoor unit (L)	Actual pipe length	m	75	75	75	100	100
	Equivalent pipe length	m	95	95	95	125	125
Maximum length between the 1st Multi-kit and the furthest indoor unit (L2)			30	30	30	40	40
Maximum pipe length (L3)			10	10	10	15	15
Maximum height difference between the RASC unit and the indoor unit (H-O)	RASC unit higher than the indoor unit	m	30	30	30	30	30
	Indoor unit higher than the RASC unit	m	20	20	20	20	20
Maximum height difference between indoor units (Hi)			10	10	10	10	10
Maximum total pipe length (L1 + L3 ₁ + L3 ₂ + L3 ₃)			95	95	95	100	145

- For distributions other than in-line with splitters, please contact your usual Hitachi vendor.

Pipe and splitter dimensions

Main pipe dimensions

	Liquid	Gas
RASC - 4HNPE	3/8"	5/8"
RASC - 5HNPE	3/8"	5/8"
RASC - 6HNPE	3/8"	5/8"
RASC - 8HNPE	3/8"	1"
RASC - 10HNPE	1/2"	1"

Dimensions between the splitter and the indoor unit

Indoor unit	Pipe size	
	Liquid	Gas
0.8 - 1.5 HP	1/4"	1/2"
1.8 - 2.0 HP	1/4"	5/8"
2.3 - 6.0 HP	3/8"	5/8"
8 HP	3/8"	3/4"
10 HP	3/8"	7/8"

Splitters

Outdoor unit	Multi-kit
RASC - 4HNPE	E-102SN4
RASC - 5HNPE	E-102SN4
RASC - 6HNPE	E-102SN4
RASC - 8HNPE	E-162SN4
RASC - 10HNPE	E-162SN4

Multi-kit: Splitters
E-102SN4
E-162SN4

Benefits VRF Mini

1 Extended temperature range

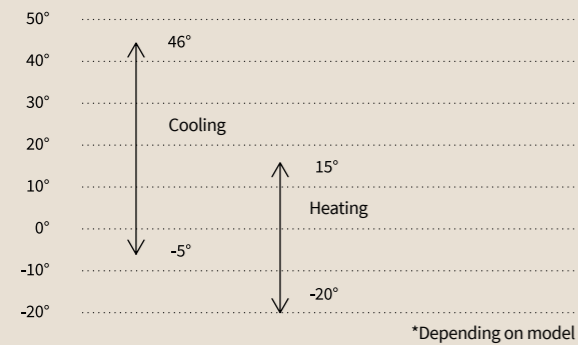

- Can work with a broad operating range.
- From -5°C to 46°C in cooling and from -20°C to 15°C in heating.

2 Conditions up to 39 rooms at different temperatures



Independently conditions and maintains the temperature in up to 39 zones, each with its own individual control. This means climate control can be adapted to the specific needs of your premises or home.

3 Flexibility and ease of installation due to longer pipe lengths

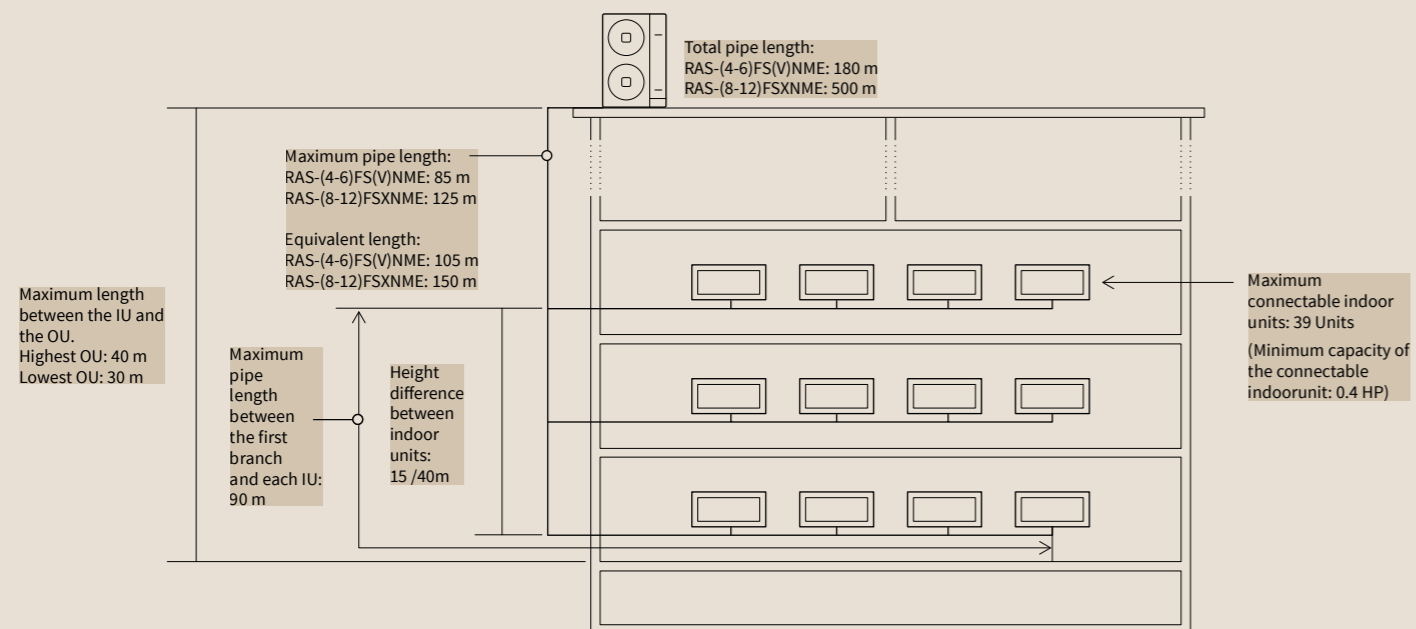

Maximum total length of the pipes: 500 m
 Combined capacity ratio: 50-130%

4 Fast, accurate diagnosis

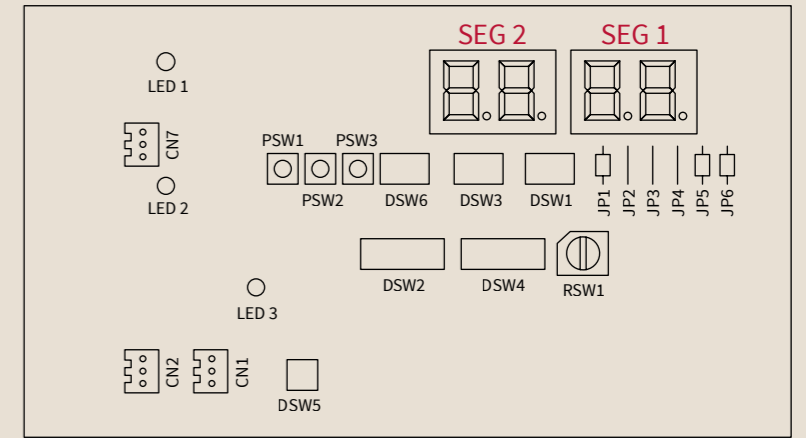

The outdoor unit's PCB board is fitted with a 7-segment display showing different parameters sequentially, e.g. outdoor air temperature, condensation temperature, discharge pressure, etc. This allows fast, accurate diagnosis of the installation and makes maintenance easier.

*In accordance with model.

5 Energy Efficiency optimised

Class 8 to 12 HP heat recovery systems work by transferring excess heating or cooling energy from areas it's being wasted to areas that it's required. This enables one system to have simultaneous, separate heating and cooling zones depending on the needs and comfort of the occupants.

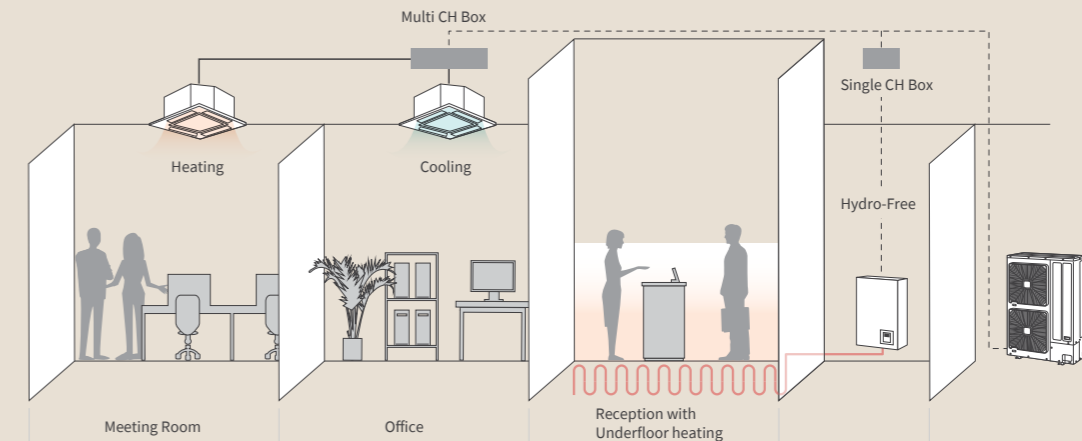

6 Smooth Drive Control for an optimised refrigerant circuit

The newly developed VRF technology Smooth Drive Control is available exclusively from Hitachi and sets new standards in terms of performance and efficiency. What does that mean for you?

- Efficiency** Electricity consumption is reduced by 39%.
- Comfort** A constant room temperature is kept due to minute adjustments to the compressor frequency as the loads change.
- Reliability** Less load on the compressor as the unit no longer switches on and off at low loads. The system can run just one 0.4 HP indoor unit.

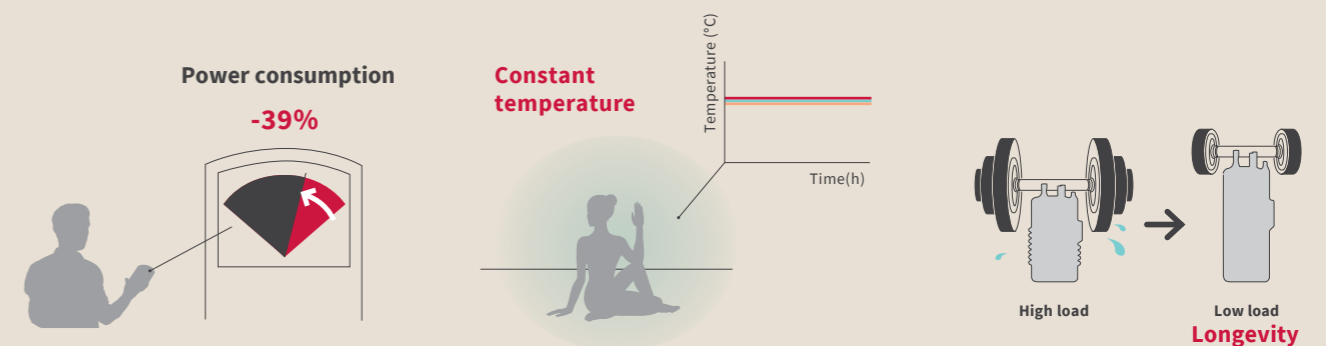

VRF Set Free Mini

Compact air conditioning for all types of installations without having to install the outdoor unit on the roof

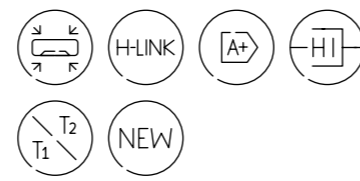

Improved air flow with minimum noise

Its new aerodynamic design makes it the quietest on the market, with a **noise reduction** of up to 4 dB(A). The combination of a 3-blade propeller and fine-tuned fan reduces the noise level and increases reliability.

Moreover, with its Side-Flow **Technology**, the fan speed achieves uniform air distribution, resulting in considerable energy savings.

(Fig. 1)

High-efficiency Scroll compressor

The Scroll DC Inverter compressor has been designed by Hitachi to increase efficiency and reliability while reducing energy consumption. More efficiency at partial loads and low speeds. Greater energy savings and 50% weight reduction thanks to a compact design with high performance in intermediate seasons.

Straightforward installation

Greater simplicity and flexibility through distributors without the need for manifolds, achieving significant savings in installation costs.

Easily transportable

The new design of the outdoor units, **which are 30% more compact**, means they can be easily transported in a lift, without the need to hire a crane. This lightweight design with reduced size ensures convenience in delivery and installation, along with significant savings.

Fig. 1

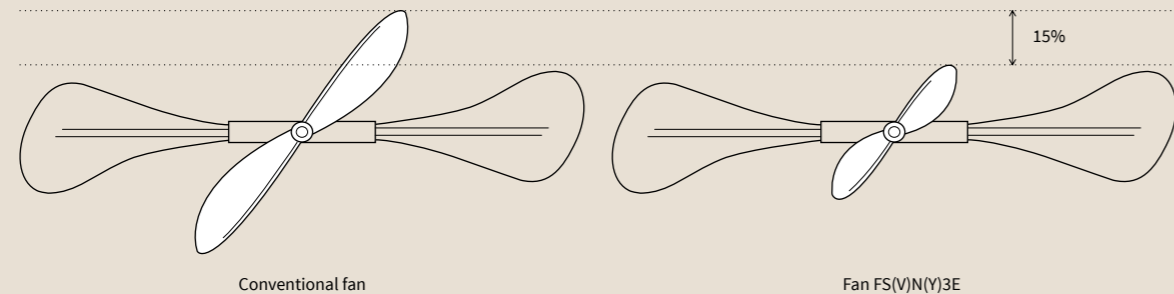

Outdoor units

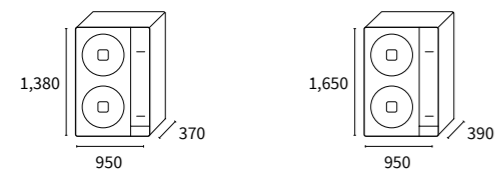

RAS-4FS(V)NME
RAS-5FS(V)NME
RAS-6FS(V)NME

RAS-8FSXNME
RAS-10FSXNME
RAS-12FSXNME

VRF Set Free Mini

Outdoor unit			RAS-4FS(V)NME	RAS-5FS(V)NME	RAS-6FS(V)NME	RAS-8FSXNME	RAS-10FSXNME	RAS-12FSXNME
Maximum number of connectable indoor units			13 (6)*	16 (7)*	18 (8)*	26 (17)*	32 (21)*	39 (26)*
Capacity index *	%		50-130	50-130	50-130	50-130	50-130	50-130
Nominal Capacity	Cooling (Min/Nom/Max)	kW	12.10	14.00	16.00	22.40	28.00	33.50
	Heating (Min/Nom/Max)	kW	12.50	16.00	18.00	25.00	31.50	37.50
Consumption	Cooling (nominal) Single/Three	kW	2.97/2.97	3.26/3.26	4.35/4.35	6.25	7.27	9.36
	Heating (nominal) Single/Three	kW	2.89/2.89	3.57/3.57	4.30/4.30	5.32	6.89	9.15
EER	Single-phase		4.07	4.29	3.68	-	-	-
	Three-phase		4.07	4.29	3.68	3.60	3.85	3.58
COP	Single-phase		4.33	4.48	4.19	-	-	-
	Three-phase		4.33	4.48	4.19	4.70	4.57	4.10
SEER	Single-phase		6.67	6.64	6.40	-	-	-
	Three-phase		6.61	6.61	6.37	7.59	8.31	8.26
SCOP	Single-phase		4.15	4.40	4.25	-	-	-
	Three-phase		4.15	4.40	4.25	5.62	4.72	4.66
Electrical power			1 ~230V 50Hz	1 ~230V 50Hz	1 ~230V 50Hz	-	-	-
			3N ~400V 50 Hz	3N ~400V 50 Hz	3N ~400V 50 Hz	3N ~400V 50 Hz	3N ~400V 50 Hz	3N ~400V 50 Hz
Maximum current	Single-phase	A	29.0	29.0	29.0	-	-	-
	Three-phase	A	16.0	16.0	16.0	18.0	19.0	23.0
Indoor/outdoor wiring section (shielded)		mm	2x0.75	2x0.75	2x0.75	2x0.75	2x0.75	2x0.75
Outside operating temperatures	Cooling (DB)	°C	-5 to 48	-5 to 48	-5 to 48	-5 to 48	-5 to 48	-5 to 48
	Heating (WB)	°C	-20 to 15	-20 to 15	-20 to 15	-20 to 15	-20 to 15	-20 to 15
Nominal Air flow		m ³ /h	8,400	8,400	8,400	9,900	11,100	11,100
Sound pressure		dB(A)	52	52	53	55	59	60
Sound power		dB(A)	69	69	70	76	77	77
N° fans			2	2	2	2	2	2
Pipe diameter	Liquid-gas	inches	3/8-5/8	3/8-5/8	3/8-5/8	3/8-3/4-5/8	3/8-7/8-3/4	1/2-1 1/8-7/8
Maximum pipe length		m	85	85	85	125	125	125
Maximum height difference (highest OU/lowest OU)		m	30/30	30/30	30/30	50/40	50/40	50/40
Compressor			Twin Rotary	Twin Rotary	Twin Rotary	Scroll DC Inverter	Scroll DC Inverter	Scroll DC Inverter
Refrigerant			R410A	R410A	R410A	R410A	R410A	R410A
Refrigerant charge (length without additional charge)		kg (m)	3.7 (must be calculated)	3.7 (must be calculated)	4.1 (must be calculated)	4.2 (must be calculated)	6.0 (must be calculated)	6.0 (must be calculated)
Additional refrigerant charge		g/m	must be calculated	must be calculated	must be calculated	must be calculated	must be calculated	must be calculated
Dimensions (H x W x D)		mm	1,380x950x370	1,380x950x370	1,380x950x370	1,650x1,100x390	1,650x1,100x390	1,650x1,100x390
Weight	Single-phase	kg	114.0	114.0	118.0	-	-	-
	Three-phase	kg	115.0	115.0	119.0	188.0	194.0	196.0

*Ask about limitations on combining some indoor units.

Benefits

Set Free Sigma

1 Guaranteed heating performance

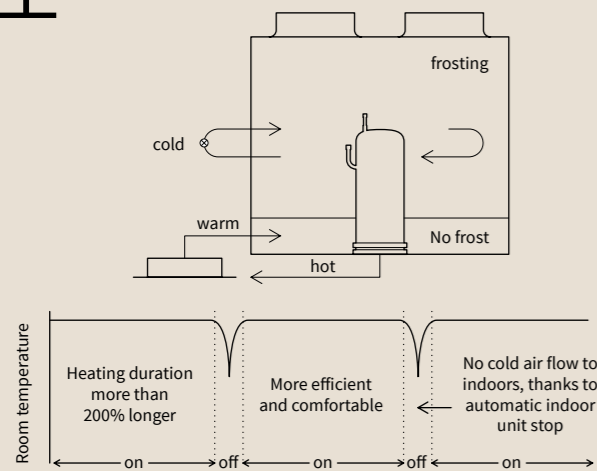

Thanks to Set Free Sigma technology, the temperature drop during a defrost cycle is restricted to an imperceptible **0.1°C**. This is achieved with a new and improved sensor, which intelligently manages when the units go into defrost, a hot gas bypass through the bottom half of the heat exchanger which prevents ice from forming, alternating defrost in groups of outdoors and the indoor units automatically stopping the fans to protect user comfort.

2 Leading performance



Set Free Sigma complies with the efficiency requirements of the ErP Directive, and more specifically with Lot 21 for VRF units. The improvements in this range, namely the Sigma heat exchanger, fans, control and compressor, mean SEER values of up to 8.33 and SCOP of up to 5.06 can be achieved.

3 Smooth drive control

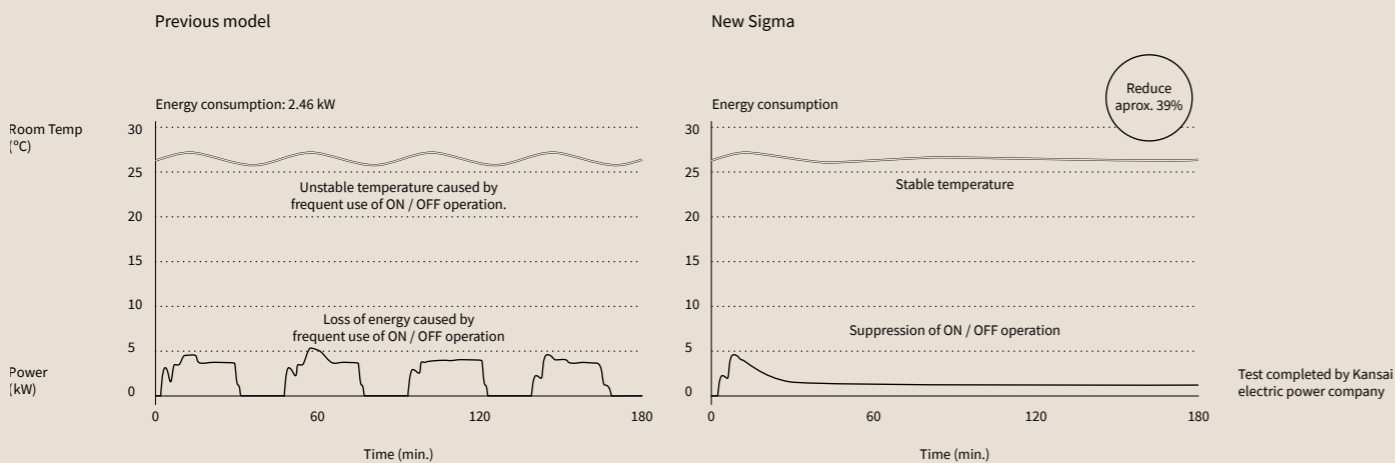

One of the features of VRF technology is that it can use the inverter compressor to adjust cooling system capacity, making it a precise, efficient technology. Smooth drive goes further and revolutionises inverter compressor operation by adjusting its capacity in steps of 0.1Hz.

This further increases energy efficiency and temperature accuracy, thereby improving energy savings and comfort. The estimated energy saving for the tested case is 39%, as can be seen in the previous figure.

4 Flexibility in installation

- 1. Wall-mounted
- 2. Outdoor unit
- 3. Duct

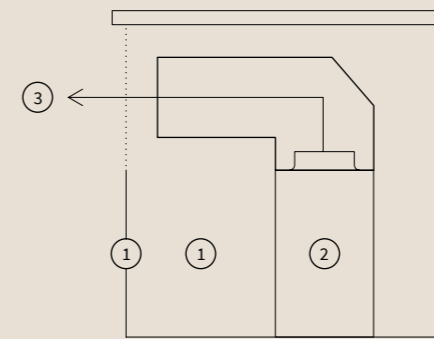

The system can be installed outdoors, which ensures good ventilation, or indoors inside a specific room. Thanks to the static pressure of its fans, which can be adjusted in steps of 0, 30, 60 or 80 Pa, the system can be installed indoors with an air output system.

5 Prepared for Passivhaus

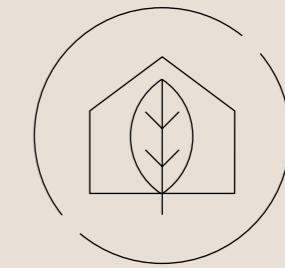

The improvement in the quality of new buildings means they have lower energy needs. 0.4 HP System Free units (1,100W) are ideal for these applications with lower gas charges and reduced energy consumption.

6 Adapted to the needs of each project

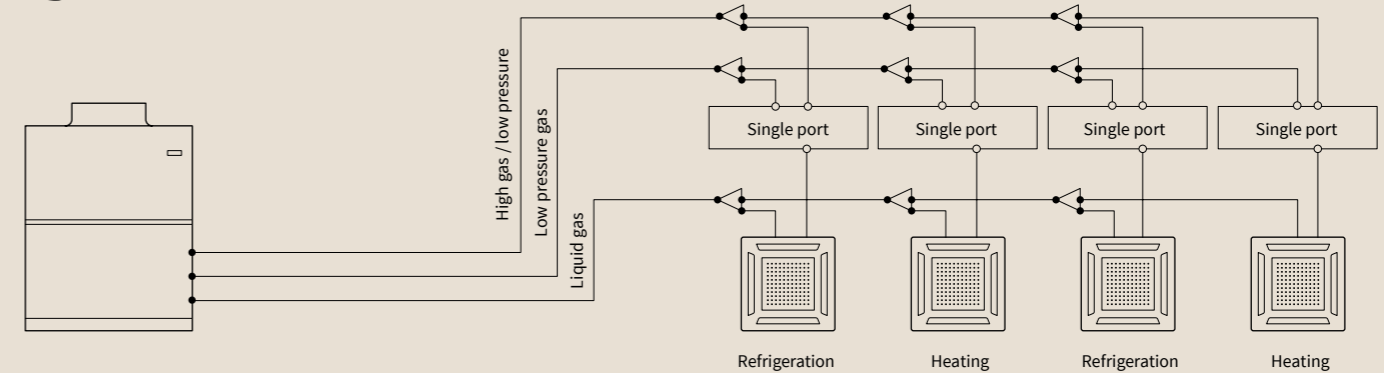

- Welded joint
- Flare connection

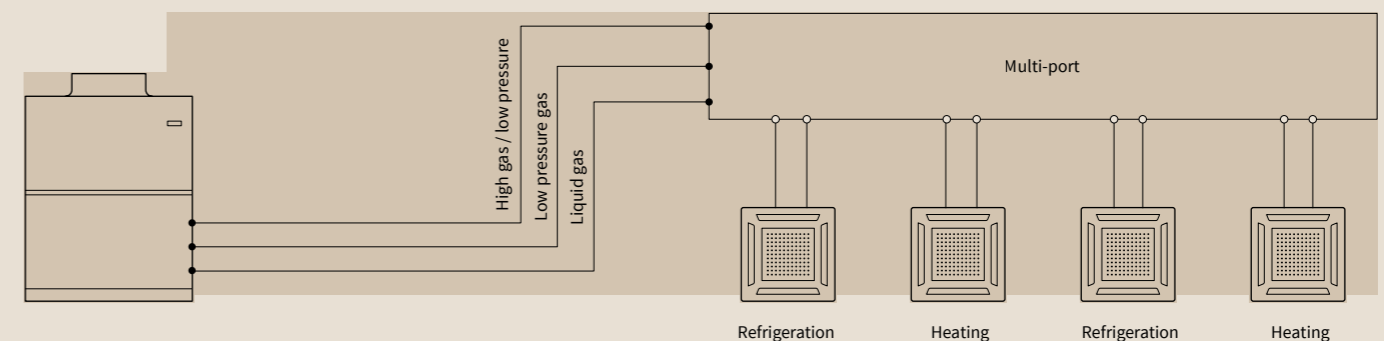

- Welded joint
- Flare connection

Extensive range of heat recovery boxes, from single-output boxes to multiple boxes with up to 16 outputs. The most compact and lightest on the market.

- Our systems are easy to install thanks to:
- Simplified cooling connections: fewer connections to be welded.
 - No need for connection to a drainage network.
 - Reduced installation time and cost.

*Available in the fourth quarter of 2018.



0.4 HP indoor units:
Ideal for energy efficient buildings



5 HP outdoor units:
Unique in the market

HOTEL

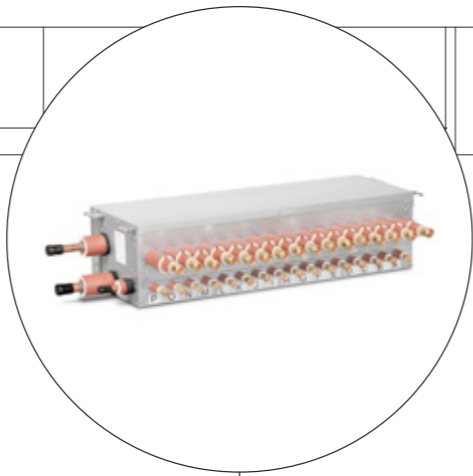
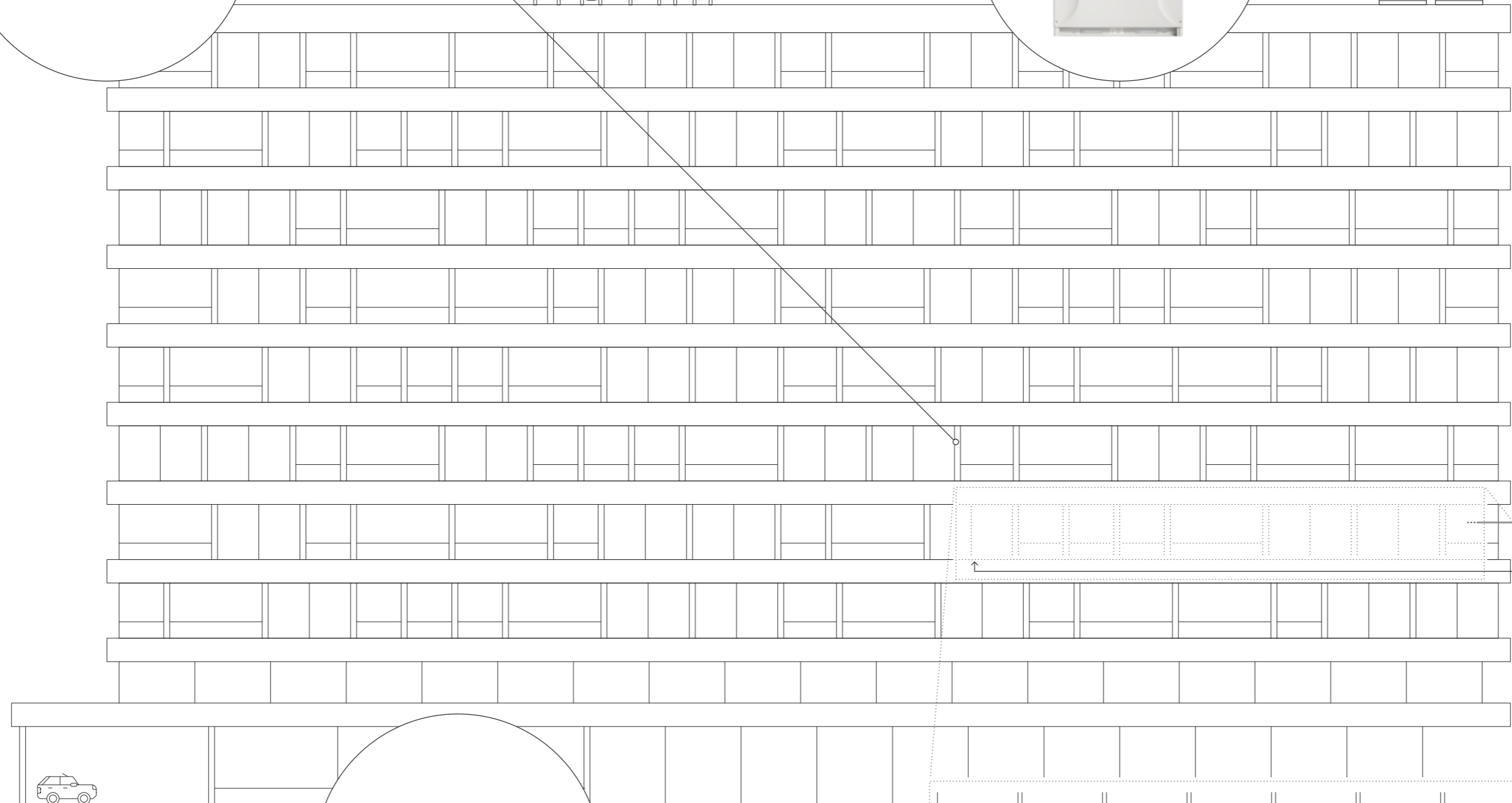

Multi CH Box
for 16 indoor units

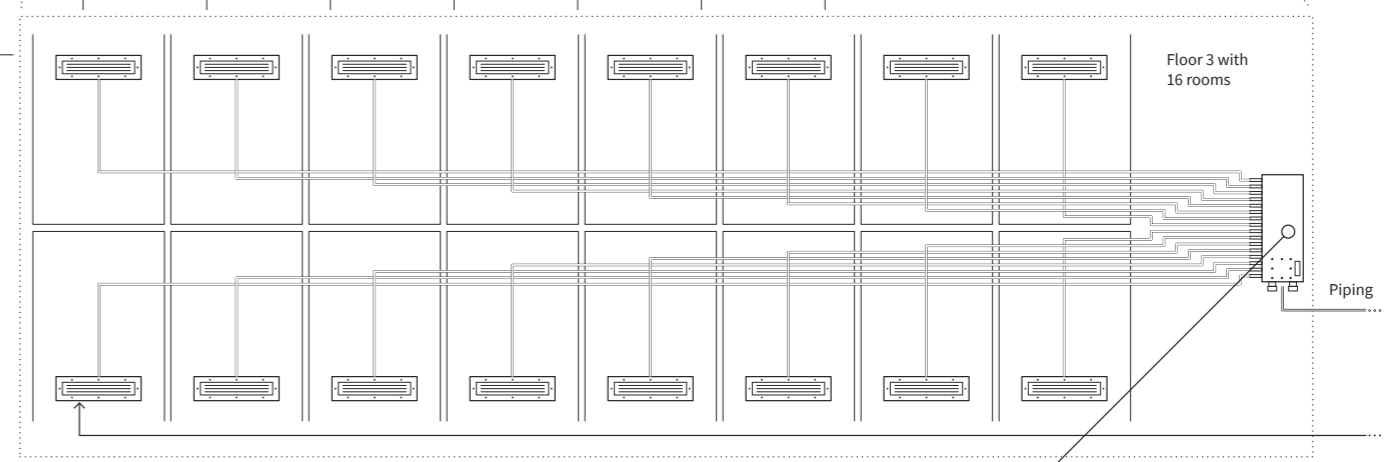

Maximum
pipe length
165 m

Maximum
height difference
110 m

Piping

Floor 3 with
16 rooms

Piping

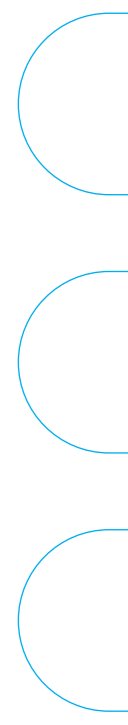

VRF Set Free Sigma Standard

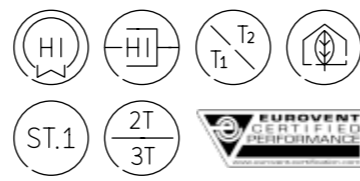

The most flexible heat recovery range

It offers the widest range of recovery boxes, from single-output boxes to multiple boxes with up to 16 outputs. It is the most compact and lightest on the market.

Installation is also much more straightforward and economical, since the insulation used removes the need to install a condensate tray, the liquid line goes directly to the indoor unit without passing through the box, thus meaning fewer connections.

Leader in energy efficiency

The heat exchange surface has been enlarged thanks to the new "Sigma" shaped condenser battery, which, combined with the improvement in the compressor at low partial charges and also the new fan, makes it **the most efficient VRF on the market.**

Extensive range available for 2 and 3 pipes

Up to 268 kW (96 HP) in combination with several modules.

Individual modules up to 67 kW (24 HP) ensure space and cost savings when roof space is limited.

Extensive operating ranges

Extended operating range in cooling mode, up to 48°C in summer and -10°C in winter.

Outdoor units (individual module)

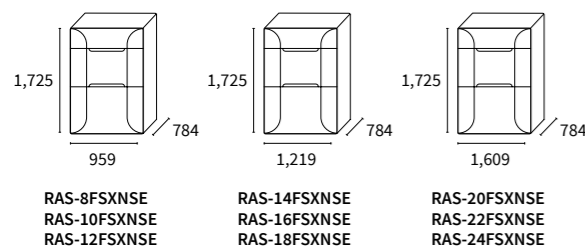

VRF Set Free Sigma Standard

Outdoor unit		RAS-8FSXNSE	RAS-10FSXNSE	RAS-12FSXNSE	RAS-14FSXNSE	RAS-16FSXNSE	RAS-18FSXNSE	RAS-20FSXNSE	RAS-22FSXNSE
Combination of modules									
Maximum number of connectable indoor units		26	32	39	45	52	58	64	64
Capacity index *	%	50-130	50-130	50-130	50-130	50-130	50-130	50-130	50-130
Capacity	Cooling (nominal) kW	22.40	28.00	33.50	40.00	45.00	50.00	56.00	61.50
	Heating (nominal) kW	25.00	31.50	37.50	45.00	50.00	56.00	63.00	69.00
Consumption	Cooling (nominal) kW	5.40	7.27	8.89	12.12	13.85	14.93	18.60	20.43
	Heating (nominal) kW	5.26	6.89	9.15	12.03	14.84	17.02	18.81	21.63
Electrical power		3N ~400V 50 Hz	3N ~400V 50 Hz	3N ~400V 50 Hz	3N ~400V 50 Hz	3N ~400V 50 Hz	3N ~400V 50 Hz	3N ~400V 50 Hz	3N ~400V 50 Hz
Maximum current	A	15.5	21.5	24.0	29.5	33.0	37.5	44.5	45.0
Indoor/outdoor wiring section (shielded)	mm	2x0.75	2x0.75	2x0.75	2x0.75	2x0.75	2x0.75	2x0.75	2x0.75
EER		4.15	3.85	3.77	3.30	3.25	3.35	3.01	3.01
COP		4.75	4.57	4.10	3.74	3.37	3.29	3.35	3.19
SEER		7.50	7.17	6.97	7.47	7.30	6.96	6.29	6.76
SCOP		4.17	4.11	4.29	4.48	4.42	4.18	4.14	4.43
Outside operating temperatures	Cooling (DB) °C	-10 to 48	-10 to 48	-10 to 48	-10 to 48	-10 to 48	-10 to 48	-10 to 48	-10 to 48
	Heating (WB) °C	-20 to 15	-20 to 15	-20 to 15	-20 to 15	-20 to 15	-20 to 15	-20 to 15	-20 to 15
Air flow	m3/h	9,900	10,200	11,400	14,340	15,360	15,360	19,740	19,740
Available pressure	Pa	30-60-80	30-60-80	30-60-80	30-60-80	30-60-80	30-60-80	30-60-80	30-60-80
N° fans		1	1	1	2	2	2	2	2
Sound pressure	dB(A)	58	60	59	63	63	65	65	64
Sound power	dB(A)	80	82	82	85	85	86	86	84
Pipe diameter	Liquid-low gas-high gas inches	3/8-3/4-5/8	3/8-7/8-3/4	1/2-1-7/8	1/2-1-7/8	1/2-1 1/8-7/8	5/8-1 1/8-7/8	5/8-1 1/8-7/8	5/8-1 1/8-1
N° and type of compressor		1 Scroll Inverter	1 Scroll Inverter	1 Scroll Inverter	1 Scroll Inverter	2 Scroll Inverters	2 Scroll Inverters	2 Scroll Inverters	2 Scroll Inverters
Refrigerant		R410A	R410A	R410A	R410A	R410A	R410A	R410A	R410A
Refrigerant charge	kg (m)	5.0	5.0	7.2	8.9	9.9	10.7	11.3	11.3
Dimensions (H x W x D)	mm	1,725x959x784	1,725x 959x784	1,725x 959x784	1,725x1,219x784	1,725x1,219x784	1,725x1,219x784	1,725x1,609x784	1,725x1,609x784
Weight	kg	210.0	210.0	233.0	289.0	332.0	333.0	382.0	396.0

Outdoor unit		RAS-24FSXNSE	RAS-26FSXNSE	RAS-28FSXNSE	RAS-30FSXNSE	RAS-32FSXNSE	RAS-34FSXNSE	RAS-36FSXNSE	RAS-38FSXNSE
Combination of modules			RAS-12FSXNSE RAS-14FSXNSE	RAS-12FSXNSE RAS-16FSXNSE	RAS-12FSXNSE RAS-18FSXNSE	RAS-14FSXNSE RAS-18FSXNSE	RAS-16FSXNSE RAS-18FSXNSE	RAS-18FSXNSE RAS-18FSXNSE	RAS-14FSXNSE RAS-24FSXNSE
Maximum number of connectable indoor units		64	64	64	64	64	64	64	64
Capacity index *	%	50-130	50-130	50-130	50-130	50-130	50-130	50-130	50-130
Capacity	Cooling (nominal) kW	67.00	73.00	77.50	85.00	90.00	95.00	100.00	106.00
	Heating (nominal) kW	77.50	82.50	90.00	95.00	100.00	106.00	112.00	118.00
Consumption	Cooling (nominal) kW	22.41	23.38	22.44	24.24	29.58	28.77	29.85	36.71
	Heating (nominal) kW	22.79	21.18	24.67	26.59	28.77	31.86	34.04	33.55
Electrical power		3N ~400V 50 Hz	3N ~400V 50 Hz	3N ~400V 50 Hz	3N ~400V 50 Hz	3N ~400V 50 Hz	3N ~400V 50 Hz	3N ~400V 50 Hz	3N ~400V 50 Hz
Maximum current	A	53.0	53.0	56.5	61.0	66.5	70.5	75.0	82.5
Indoor/outdoor wiring section (shielded)	mm	2x0.75	2x0.75	2x0.75	2x0.75	2x0.75	2x0.75	2x0.75	2x0.75
EER		2.99	3.12	3.45	3.51	3.04	3.30	3.35	2.89
COP		3.40	3.90	3.65	3.57	3.48	3.33	3.29	3.52
SEER		6.20	7.30	7.10	7.11	7.36	7.18	7.20	6.63
SCOP		4.43	4.39	4.35	4.22	4.30	4.28	4.18	4.45
Outside operating temperatures	Cooling (DB) °C	-10 to 48	-10 to 48	-10 to 48	-10 to 48	-10 to 48	-10 to 48	-10 to 48	-10 to 48
	Heating (WB) °C	-20 to 15	-20 to 15	-20 to 15	-20 to 15	-20 to 15	-20 to 15	-20 to 15	-20 to 15
Air flow	m3/h	20,880	25,740	26,760	26,760	29,700	30,720	30,720	35,220
Available pressure	Pa	30-60-80	30-60-80	30-60-80	30-60-80	30-60-80	30-60-80	30-60-80	30-60-80
N° fans		2	3	3	3	4	4	4	4
Sound pressure	dB(A)	66	65	65	66	67	67	68	68
Sound power	dB(A)	86	87	87	87	89	89	89	89
Pipe diameter	Liquid-low gas-high gas inches	5/8-1 1/8-1	3/4-1 1/4-1	3/4-1 1/4-1 1/8	3/4-1 1/4-1 1/8	3/4-1 1/4-1 1/8	3/4-1 1/4-1 1/8	3/4-1 1/2-1 1/8	3/4-1 1/2-1 1/4
N° and type of compressor		2 Scroll Inverters	2 Scroll Inverters	3 Scroll Inverters	3 Scroll Inverters	3 Scroll Inverters	4 Scroll Inverters	4 Scroll Inverters	3 Scroll Inverters
Refrigerant		R410A	R410A	R410A	R410A	R410A	R410A	R410A	R410A
Refrigerant charge	kg (m)	11.6	16.1	17.1	17.9	19.6	20.6	21.4	20.5
Dimensions (H x W x D)	mm	1,725x1,609x784	1,725x2,198x784	1,725x2,198x784	1,725x2,198x784	1,725x2,458x784	1,725x2,458x784	1,725x2,458x784	1,725x2,848x784
Weight	kg	397.0	522.0	565.0	566.0	622.0	665.0	666.0	686.0

Compatible controls and accessories:

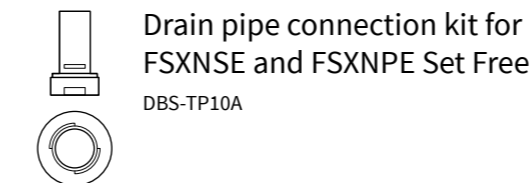

Outdoor unit		RAS-40FSXNSE	RAS-42FSXNSE	RAS-44FSXNSE	RAS-46FSXNSE	RAS-48FSXNSE	RAS-50FSXNSE	RAS-52FSXNSE	RAS-54FSXNSE	
Combination of modules		RAS-18FSXNSE RAS-22FSXNSE	RAS-18FSXNSE RAS-24FSXNSE	RAS-22FSXNSE RAS-22FSXNSE	RAS-22FSXNSE RAS-24FSXNSE	RAS-24FSXNSE RAS-24FSXNSE	RAS-14FSXNSE RAS-18FSXNSE RAS-18FSXNSE	RAS-16FSXNSE RAS-18FSXNSE RAS-18FSXNSE	RAS-18FSXNSE RAS-18FSXNSE RAS-18FSXNSE	
Maximum number of connectable indoor units		64	64	64	64	64	64	64	64	
Capacity index *		%	50-130	50-130	50-130	50-130	50-130	50-130	50-130	
Capacity	Cooling (nominal)	kW	112.00	118.00	122.00	128.00	136.00	140.00	145.00	150.00
	Heating (nominal)	kW	125.00	132.00	140.00	145.00	150.00	155.00	160.00	165.00
Consumption	Cooling (nominal)	kW	35.52	37.65	40.53	42.67	45.48	44.50	43.70	44.78
	Heating (nominal)	kW	38.65	39.37	43.89	43.97	44.12	45.49	48.28	50.15
Electrical power			3N ~400V 50 Hz	3N ~400V 50 Hz	3N ~400V 50 Hz	3N ~400V 50 Hz	3N ~400V 50 Hz	3N ~400V 50 Hz	3N ~400V 50 Hz	3N ~400V 50 Hz
Maximum current		A	82.0	90.5	89.5	98.0	106.0	104.0	108.0	112.0
Indoor/outdoor wiring section (shielded)		mm	2x0.75	2x0.75	2x0.75	2x0.75	2x0.75	2x0.75	2x0.75	2x0.75
EER			3.15	3.13	3.01	3.00	2.99	3.15	3.32	3.35
COP			3.23	3.35	3.19	3.30	3.40	3.41	3.31	3.29
SEER			6.93	6.57	6.75	6.45	6.19	7.30	7.18	7.20
SCOP			4.30	4.31	4.43	4.43	4.43	4.26	4.25	4.18
Outside operating temperatures	Cooling (DB)	°C	-10 to 48	-10 to 48	-10 to 48	-10 to 48	-10 to 48	-10 to 48	-10 to 48	-10 to 48
	Heating (WB)	°C	-20 to 15	-20 to 15	-20 to 15	-20 to 15	-20 to 15	-20 to 15	-20 to 15	-20 to 15
Air flow		m3/h	35,100	36,240	39,480	40,620	41,760	45,060	46,080	46,080
Available pressure		Pa	30-60-80	30-60-80	30-60-80	30-60-80	30-60-80	30-60-80	30-60-80	30-60-80
N° fans			4	4	4	4	4	6	6	6
Sound pressure		dB(A)	68	69	67	68	69	69	69	70
Sound power		dB(A)	88	89	87	88	89	90	90	91
Pipe diameter		Liquid-low gas-high gas	inches	3/4-1 1/2-1 1/4	3/4-1 1/2-1 1/4	3/4-1 1/2-1 1/4	3/4-1 1/2-1 1/4	3/4-1 1/2-1 1/4	3/4-1 1/2-1 1/4	3/4-1 1/2-1 1/4
N° and type of compressor			4 Scroll Inverters	4 Scroll Inverters	4 Scroll Inverters	4 Scroll Inverters	4 Scroll Inverters	5 Scroll Inverters	6 Scroll Inverters	6 Scroll Inverters
Refrigerant			R410A	R410A	R410A	R410A	R410A	R410A	R410A	R410A
Refrigerant charge		kg (m)	22.0	22.3	22.6	22.9	23.2	30.3	31.3	32.1
Dimensions (H x W x D)		mm	1,725x2,848x784	1,725x2,848x784	1,725x3,238x784	1,725x3,238x784	1,725x3,238x784	1,725x3,697x784	1,725x3,697x784	1,725x3,697x784
Weight		kg	729.0	730.0	792.0	793.0	794.0	955.0	998.0	999.0

Outdoor unit		RAS-56FSXNSE	RAS-58FSXNSE	RAS-60FSXNSE	RAS-62FSXNSE	RAS-64FSXNSE	RAS-66FSXNSE	RAS-68FSXNSE	RAS-70FSXNSE	
Combination of modules		RAS-14FSXNSE RAS-18FSXNSE RAS-24FSXNSE	RAS-18FSXNSE RAS-18FSXNSE RAS-24FSXNSE	RAS-18FSXNSE RAS-18FSXNSE RAS-24FSXNSE	RAS-14FSXNSE RAS-24FSXNSE RAS-24FSXNSE	RAS-18FSXNSE RAS-22FSXNSE RAS-24FSXNSE	RAS-18FSXNSE RAS-24FSXNSE RAS-24FSXNSE	RAS-22FSXNSE RAS-24FSXNSE RAS-24FSXNSE	RAS-22FSXNSE RAS-24FSXNSE RAS-24FSXNSE	
Maximum number of connectable indoor units		64	64	64	64	64	64	64	64	
Capacity index *		%	50-130	50-130	50-130	50-130	50-130	50-130	50-130	
Capacity	Cooling (nominal)	kW	157.00	162.00	167.00	174.00	179.00	184.00	190.00	196.00
	Heating (nominal)	kW	176.00	181.00	188.00	196.00	202.00	207.00	213.00	220.00
Consumption	Cooling (nominal)	kW	51.99	50.44	52.26	59.47	57.93	59.74	63.27	65.41
	Heating (nominal)	kW	51.12	55.67	56.39	56.47	61.29	61.42	65.29	66.02
Electrical power			3N ~400V 50 Hz	3N ~400V 50 Hz	3N ~400V 50 Hz	3N ~400V 50 Hz	3N ~400V 50 Hz	3N ~400V 50 Hz	3N ~400V 50 Hz	3N ~400V 50 Hz
Maximum current		A	120.0	120.0	128.0	136.0	136.0	144.0	143.0	151.0
Indoor/outdoor wiring section (shielded)		mm	2x0.75	2x0.75	2x0.75	2x0.75	2x0.75	2x0.75	2x0.75	2x0.75
EER			3.02	3.21	3.20	2.93	3.09	3.08	3.00	3.00
COP			3.44	3.25	3.33	3.47	3.30	3.37	3.26	3.33
SEER			6.79	7.01	6.75	6.45	6.63	6.43	6.54	6.36
SCOP			4.35	4.26	4.27	4.44	4.35	4.35	4.43	4.43
Outside operating temperatures	Cooling (DB)	°C	-10 to 48	-10 to 48	-10 to 48	-10 to 48	-10 to 48	-10 to 48	-10 to 48	-10 to 48
	Heating (WB)	°C	-20 to 15	-20 to 15	-20 to 15	-20 to 15	-20 to 15	-20 to 15	-20 to 15	-20 to 15
Air flow		m3/h	50,580	50,460	51,600	56,100	55,980	57,120	60,360	61,500
Available pressure		Pa	30-60-80	30-60-80	30-60-80	30-60-80	30-60-80	30-60-80	30-60-80	30-60-80
N° fans			6	6	6	6	6	6	6	6
Sound pressure		dB(A)	70	70	70	70	70	71	70	70
Sound power		dB(A)	90	90	91	90	90	91	90	90
Pipe diameter		Liquid-low gas-high gas	inches	3/4-1 3/4	3/4-1 3/4	3/4-1 3/4	3/4-1 3/4	3/4-1 3/4	3/4-1 3/4	3/4-1 3/4
N° and type of compressor			5 Scroll Inverters	6 Scroll Inverters	6 Scroll Inverters	5 Scroll Inverters	6 Scroll Inverters	6 Scroll Inverters	6 Scroll Inverters	6 Scroll Inverters
Refrigerant			R410A	R410A	R410A	R410A	R410A	R410A	R410A	R410A
Refrigerant charge		kg (m)	31.2	32.7	33.0	32.1	33.6	33.9	34.2	34.5
Dimensions (H x W x D)		mm	1,725x4,087x784	1,725x4,087x784	1,725x4,087x784	1,725x4,477x784	1,725x4,477x784	1,725x4,477x784	1,725x4,867x784	1,725x4,867x784
Weight		kg	1,019.0	1,062.0	1,063.0	1,083.0	1,126.0	1,127.0	1,189.0	1,190.0

*Ask about limitations on combining some indoor units.

Outdoor unit		RAS-72FSXNSE	RAS-74FSXNSE	RAS-76FSXNSE	RAS-78FSXNSE	RAS-80FSXNSE	RAS-82FSXNSE	RAS-84FSXNSE	RAS-86FSXNSE	
Combination of modules		RAS-24FSXNSE RAS-24FSXNSE RAS-24FSXNSE	RAS-14FSXNSE RAS-18FSXNSE RAS-18FSXNSE	RAS-18FSXNSE RAS-18FSXNSE RAS-22FSXNSE	RAS-18FSXNSE RAS-18FSXNSE RAS-24FSXNSE	RAS-14FSXNSE RAS-18FSXNSE RAS-24FSXNSE	RAS-16FSXNSE RAS-18FSXNSE RAS-24FSXNSE	RAS-18FSXNSE RAS-24FSXNSE RAS-24FSXNSE	RAS-18FSXNSE RAS-24FSXNSE RAS-24FSXNSE	
Maximum number of connectable indoor units		64	64	64	64	64	64	64	64	
Capacity index *		%	50-130	50-130	50-130	50-130	50-130	50-130	50-130	
Capacity	Cooling (nominal)	kW	201.00	207.00	212.00	217.00	224.00	230.00	234.00	241.00
	Heating (nominal)	kW	225.00	232.00	237.00	244.00	254.00	261.00	267.00	275.00
Consumption	Cooling (nominal)	kW	67.22	66.91	65.36	67.18	74.39	73.91	74.67	81.88
	Heating (nominal)	kW	66.18	68.13	72.69	73.41	74.06	77.45	79.63	79.69
Electrical power			3N ~400V 50 Hz	3N ~400V 50 Hz	3N ~400V 50 Hz	3N ~400V 50 Hz	3N ~400V 50 Hz	3N ~400V 50 Hz	3N ~400V 50 Hz	
Maximum current		A	159.0	158.0	158.0	166.0	173.0	177.0	181.0	189.0
Indoor/outdoor wiring section (shielded)		mm	2x0.75	2x0.75	2x0.75	2x0.75	2x0.75	2x0.75	2x0.75	2x0.75
EER			2.99	3.09	3.24	3.23	3.01	3.11	3.13	2.94
COP			3.40	3.41	3.26	3.32	3.43	3.37	3.35	3.45
SEER			6.19	6.89	7.05	6.85	6.60	6.57	6.58	6.38
SCOP			4.43	4.31	4.24	4.24	4.37	4.35	4.31	4.44
Outside operating temperatures	Cooling (DB)	°C	-10 to 48	-10 to 48	-10 to 48	-10 to 48	-10 to 48	-10 to 48	-10 to 48	-10 to 48
	Heating (WB)	°C	-20 to 15	-20 to 15	-20 to 15	-20 to 15	-20 to 15	-20 to 15	-20 to 15	-20 to 15
Air flow		m3/h	62,640	65,940	65,820	66,960	71,460	72,480	72,480	76,980
Available pressure		Pa	30-60-80	30-60-80	30-60-80	30-60-80	30-60-80	30-60-80	30-60-80	30-60-80
N° fans			6	8	8	8	8	8	8	8
Sound pressure		dB(A)	71	71	71	72	71	71	72	72
Sound power		dB(A)	91	92	92	92	92	92	92	92
Pipe diameter		Liquid-low gas-high gas	inches	3/4-1 3/4	3/4-2	3/4-2	3/4-2	3/4-2	3/4-2	3/4-2
N° and type of compressor			6 Scroll Inverters	7 Scroll Inverters	8 Scroll Inverters	8 Scroll Inverters	7 Scroll Inverters	8 Scroll Inverters	8 Scroll Inverters	7 Scroll Inverters
Refrigerant			R410A	R410A	R410A	R410A	R410A	R410A	R410A	R410A
Refrigerant charge		kg (m)	34.8	41.9	43.4	43.7	42.8	43.8	44.6	43.7
Dimensions (H x W x D)		mm	1,725x4,867x784	1,725x5,326x784	1,725x5,326x784	1,725x5,326x784	1,725x5,716x784	1,725x5,716x784	1,725x5,716x784	1,725x6,106x784
Weight		kg	1,191.0	1,352.0	1,395.0	1,396.0	1,416.0	1,459.0	1,460.0	1,480.0

Outdoor unit		RAS-88FSXNSE	RAS-90FSXNSE	RAS-92FSXNSE	RAS-94FSXNSE	RAS-96FSXNSE	
Combination of modules		RAS-16FSXNSE RAS-24FSXNSE RAS-24FSXNSE RAS-24FSXNSE	RAS-18FSXNSE RAS-24FSXNSE RAS-24FSXNSE RAS-24FSXNSE	RAS-22FSXNSE RAS-22FSXNSE RAS-24FSXNSE RAS-24FSXNSE	RAS-22FSXNSE RAS-24FSXNSE RAS-24FSXNSE RAS-24FSXNSE	RAS-24FSXNSE RAS-24FSXNSE RAS-24FSXNSE RAS-24FSXNSE	
Maximum number of connectable indoor units		64	64	64	64	64	
Capacity index *		%	50-130	50-130	50-130	50-130	
Capacity	Cooling (nominal)	kW	246.00	251.00	258.00	263.00	268.00
	Heating (nominal)	kW	282.00	287.00	293.00	299.00	305.00
Consumption	Cooling (nominal)	kW	81.07	82.15	86.01	87.82	89.63
	Heating (nominal)	kW	83.07	84.96	88.85	89.27	89.71
Electrical power			3N ~400V 50 Hz	3N ~400V 50 Hz	3N ~400V 50 Hz	3N ~400V 50 Hz	3N ~400V 50 Hz
Maximum current		A	192.0	197.0	196.0	204.0	212.0
Indoor/outdoor wiring section (shielded)		mm	2x0.75	2x0.75	2x0.75	2x0.75	2x0.75
EER			3.03	3.06	3.00	2.99	2.99
COP			3.39	3.38	3.30	3.35	3.40
SEER			6.36	6.37	6.45	6.32	6.20
SCOP			4.41	4.37	4.43	4.43	4.43
Outside operating temperatures	Cooling (DB)	°C	-10 to 48	-10 to 48	-10 to 48	-10 to 48	-10 to 48
	Heating (WB)	°C	-20 to 15	-20 to 15	-20 to 15	-20 to 15	-20 to 15
Air flow		m3/h	78,000	78,000	81,240	82,380	83,520

Pricelist VRF Set Free Sigma Standard FSXNSE

Outdoor unit	Combinations	2-pipe multikits	3-pipe multikits	
VRF Set Free Sigma FSXNSE. Heat pump/ Heat recovery	RAS-8FSXNSE	Base module	—	
	RAS-10FSXNSE	Base module	—	
	RAS-12FSXNSE	Base module	—	
	RAS-14FSXNSE	Base module	—	
	RAS-16FSXNSE	Base module	—	
	RAS-18FSXNSE	Base module	—	
	RAS-20FSXNSE	Base module	—	
	RAS-22FSXNSE	Base module	—	
	RAS-24FSXNSE	Base module	—	
	RAS-26FSXNSE	RAS-12FSXNSE - RAS-14FSXNSE	MC-21AN1	MC-21XN1
	RAS-28FSXNSE	RAS-12FSXNSE - RAS-16FSXNSE	MC-21AN1	MC-21XN1
	RAS-30FSXNSE	RAS-12FSXNSE - RAS-18FSXNSE	MC-21AN1	MC-21XN1
	RAS-32FSXNSE	RAS-14FSXNSE - RAS-18FSXNSE	MC-21AN1	MC-21XN1
	RAS-34FSXNSE	RAS-16FSXNSE - RAS-18FSXNSE	MC-21AN1	MC-21XN1
	RAS-36FSXNSE	RAS-18FSXNSE - RAS-18FSXNSE	MC-21AN1	MC-21XN1
	RAS-38FSXNSE	RAS-14FSXNSE - RAS-24FSXNSE	MC-21AN1	MC-21XN1
	RAS-40FSXNSE	RAS-18FSXNSE - RAS-22FSXNSE	MC-21AN1	MC-21XN1
	RAS-42FSXNSE	RAS-18FSXNSE - RAS-24FSXNSE	MC-21AN1	MC-21XN1
	RAS-44FSXNSE	RAS-22FSXNSE - RAS-22FSXNSE	MC-21AN1	MC-21XN1
	RAS-46FSXNSE	RAS-22FSXNSE - RAS-24FSXNSE	MC-21AN1	MC-21XN1
RAS-48FSXNSE	RAS-24FSXNSE - RAS-24FSXNSE	MC-21AN1	MC-21XN1	
RAS-50FSXNSE	RAS-14FSXNSE - RAS-18FSXNSE - RAS-18FSXNSE	MC-30AN1	MC-30XN1	
RAS-52FSXNSE	RAS-16FSXNSE - RAS-18FSXNSE - RAS-18FSXNSE	MC-30AN1	MC-30XN1	
RAS-54FSXNSE	RAS-18FSXNSE - RAS-18FSXNSE - RAS-18FSXNSE	MC-30AN1	MC-30XN1	
VRF Set Free Sigma FSNSE. Heat pump	RAS-56FSXNSE	RAS-14FSNSE - RAS-18FSNSE - RAS-24FSNSE	MC-NP31SA	
	RAS-58FSXNSE	RAS-18FSNSE - RAS-18FSNSE - RAS-22FSNSE	MC-NP31SA	
	RAS-60FSXNSE	RAS-18FSNSE - RAS-18FSNSE - RAS-24FSNSE	MC-NP31SA	
	RAS-62FSXNSE	RAS-14FSNSE - RAS-24FSNSE - RAS-24FSNSE	MC-NP31SA	
	RAS-64FSXNSE	RAS-18FSNSE - RAS-22FSNSE - RAS-24FSNSE	MC-NP31SA	
	RAS-66FSXNSE	RAS-18FSNSE - RAS-24FSNSE - RAS-24FSNSE	MC-NP31SA	
	RAS-68FSXNSE	RAS-22FSNSE - RAS-22FSNSE - RAS-24FSNSE	MC-NP31SA	
	RAS-70FSXNSE	RAS-22FSNSE - RAS-24FSNSE - RAS-24FSNSE	MC-NP31SA	
	RAS-72FSXNSE	RAS-24FSNSE - RAS-24FSNSE - RAS-24FSNSE	MC-NP31SA	
	RAS-74FSXNSE	RAS-14FSNSE - RAS-18FSNSE - RAS-18FSNSE - RAS-24FSNSE	MC-NP40SA	
	RAS-76FSXNSE	RAS-18FSNSE - RAS-18FSNSE - RAS-18FSNSE - RAS-22FSNSE	MC-NP40SA	
	RAS-78FSXNSE	RAS-18FSNSE - RAS-18FSNSE - RAS-18FSNSE - RAS-24FSNSE	MC-NP40SA	
	RAS-80FSXNSE	RAS-14FSNSE - RAS-18FSNSE - RAS-24FSNSE - RAS-24FSNSE	MC-NP40SA	
	RAS-82FSXNSE	RAS-16FSNSE - RAS-18FSNSE - RAS-24FSNSE - RAS-24FSNSE	MC-NP40SA	
	RAS-84FSXNSE	RAS-18FSNSE - RAS-18FSNSE - RAS-24FSNSE - RAS-24FSNSE	MC-NP40SA	
	RAS-86FSXNSE	RAS-14FSNSE - RAS-24FSNSE - RAS-24FSNSE - RAS-24FSNSE	MC-NP40SA	
	RAS-88FSXNSE	RAS-16FSNSE - RAS-24FSNSE - RAS-24FSNSE - RAS-24FSNSE	MC-NP40SA	
	RAS-90FSXNSE	RAS-18FSNSE - RAS-24FSNSE - RAS-24FSNSE - RAS-24FSNSE	MC-NP40SA	
	RAS-92FSXNSE	RAS-22FSNSE - RAS-22FSNSE - RAS-24FSNSE - RAS-24FSNSE	MC-NP40SA	
	RAS-94FSXNSE	RAS-22FSNSE - RAS-24FSNSE - RAS-24FSNSE - RAS-24FSNSE	MC-NP40SA	
RAS-96FSXNSE	RAS-24FSNSE - RAS-24FSNSE - RAS-24FSNSE - RAS-24FSNSE	MC-NP40SA		

2-pipe splitter

Name
E102SN4
E-162SN4
E-242SN3
E-302SN3

2-pipe manifold

Name
MH-84AN1
MH-108AN

3-pipe splitter

Name
E-52XN3
E-102XN3
E-162XN3
E-242XN3
E-322XN3

3-pipe manifold

Name
MH-108XN

CH-BOX

Type	Individual CH BOX		Multiple CH-BOX			
	CH-AP160SSX	CH-AP280SSX	CH-AP04MSSX	CH-AP08MSSX	CH-AP12MSSX	CH-AP16MSSX
Total capacity (kW)	16	28	44.8	85	85	85
Number of outputs	1	1	4	8	12	16
Max capacity per output (kW)			16	16	16	16
Maximum number of connectable units per output	7	8	6	6	6	6
Dimensions (height-width-depth) (mm)	191 x 301 x 214	191 x 301 x 214	260 x 303 x 352	260 - 543 - 352	260 - 783 - 352	260 - 1023 - 352
Weight (kg)	6	6	14	25	36	47

Multiple CH-Box



Individual CH-Box



VRF Set Free Sigma High-Efficiency

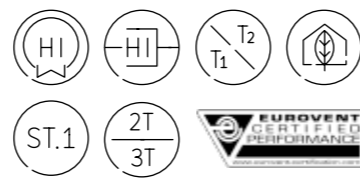

The VRF that can be installed in the tallest buildings.

The new Set Free Sigma allows greater height differences between the outdoor and indoor units of up to 110 m.

Extensive range available for 2 and 3 pipes

The only 14 kW and 16 kW (5 and 6 HP) outdoor units on the market, with very high-efficiency.

No operating limits

Extended operating range in cooling, up to +52°C in the High-Efficiency range.

Maximum comfort

Maintains a comfortable temperature during absence from the room, guaranteeing energy savings without any loss of comfort.

The most extensive range on the market

- From the smallest single module on the market, just 5 HP, to the largest 72 HP combination.

- Moreover, the whole range has common heat pump and heat recovery, exclusive to Hitachi.

Outdoor units (individual module)

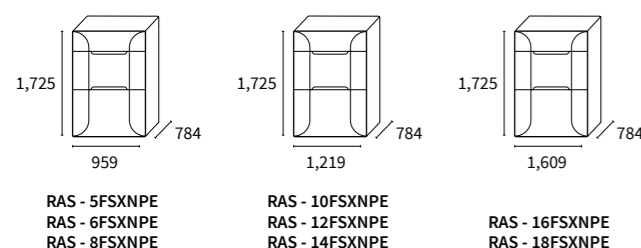

VRF Set Free Sigma High-Efficiency

Outdoor unit		RAS - 5FSXNPE	RAS - 6FSXNPE	RAS - 8FSXNPE	RAS - 10FSXNPE	RAS - 12FSXNPE	RAS - 14FSXNPE	RAS - 16FSXNPE	RAS - 18FSXNPE
Combination of modules									
Maximum number of connectable indoor units		16	19	26	32	39	45	52	58
Capacity index *	%	50-150	50-150	50-150	50-150	50-150	50-150	50-150	50-150
Capacity	Cooling (nominal) kW	14.00	16.00	22.40	28.00	33.50	40.00	45.00	50.00
	Heating (nominal) kW	16.00	18.00	25.00	31.50	37.50	45.00	50.00	56.00
Consumption	Cooling (nominal) kW	2.90	3.37	5.05	6.18	8.44	11.53	11.51	12.79
	Heating (nominal) kW	2.80	3.52	5.08	6.65	8.01	10.84	12.92	14.97
EER		4.82	4.75	4.44	4.53	3.97	3.47	3.91	3.91
COP		5.72	5.12	4.92	4.74	4.68	4.15	3.87	3.74
SEER		8.33	8.00	7.97	8.06	7.91	7.69	7.76	7.60
SCOP		5.06	4.58	4.55	4.73	4.81	4.63	4.84	4.81
Electrical power		3N ~400V 50 Hz	3N ~400V 50 Hz	3N ~400V 50 Hz	3N ~400V 50 Hz	3N ~400V 50 Hz	3N ~400V 50 Hz	3N ~400V 50 Hz	3N ~400V 50 Hz
Maximum current	A	11.5	12.0	15.0	19.0	23.0	28.0	33.0	34.5
Indoor/outdoor wiring section (shielded)	mm	2x0.75	2x0.75	2x0.75	2x0.75	2x0.75	2x0.75	2x0.75	2x0.75
Outside operating temperatures	Cooling (DB) °C	-10 to 52	-10 to 52	-10 to 52	-10 to 52	-10 to 52	-10 to 52	-10 to 52	-10 to 52
	Heating (WB) °C	-20 to 15	-20 to 15	-20 to 15	-20 to 15	-20 to 15	-20 to 15	-20 to 15	-20 to 15
Air flow	m3/h	9,000	10,200	11,100	13,140	13,140	14,580	19,560	21,720
Available pressure	Pa	30-60-80	30-60-80	30-60-80	30-60-80	30-60-80	30-60-80	30-60-80	30-60-80
N° fans		1	1	2	2	2	2	2	2
Sound pressure	dB(A)	54.00	56.00	55.00	59.00	60.00	62.00	65.00	65.00
Sound power	dB(A)	75.00	78.00	77.00	82.00	83.00	85.00	85.00	86.00
Pipe diameter	Liquid-low gas-high gas inches	3/8-5/8-1/2	3/8-3/4-5/8	3/8-3/4-5/8	3/8-7/8-3/4	1/2-1-7/8	1/2-1-7/8	1/2-7/8-7/8	5/8-7/8-7/8
N° and type of compressor		1 Scroll Inverter	1 Scroll Inverter	1 Scroll Inverter	1 Scroll Inverter	1 Scroll Inverter	1 Scroll Inverter	2 Scroll Inverters	2 Scroll Inverters
Refrigerant		R410A	R410A	R410A	R410A	R410A	R410A	R410A	R410A
Refrigerant charge	kg (m)	4.70	5.00	8.50	8.50	9.30	9.30	10.00	10.60
Dimensions (H x W x D)	mm	1,725x959x784	1,725x959x784	1,725x959x784	1,725x1,219x784	1,725x1,219x784	1,725x1,219x784	1,725x1,609x784	1,725x1,609x784
Weight	kg	210	210	274	278	282	292	369	384

Outdoor unit		RAS-20FSXNPE	RAS-22FSXNPE	RAS-24FSXNPE	RAS-26FSXNPE	RAS-28FSXNPE	RAS-30FSXNPE	RAS-32FSXNPE	RAS-34FSXNPE
Combination of modules		RAS-10FSXNPE RAS-10FSXNPE	RAS-10FSXNPE RAS-12FSXNPE	RAS-12FSXNPE RAS-12FSXNPE	RAS-10FSXNPE RAS-16FSXNPE	RAS-12FSXNPE RAS-16FSXNPE	RAS-12FSXNPE RAS-18FSXNPE	RAS-14FSXNPE RAS-18FSXNPE	RAS-16FSXNPE RAS-18FSXNPE
Maximum number of connectable indoor units		64	64	64	64	64	64	64	64
Capacity index *	%	50-150	50-150	50-150	50-150	50-150	50-150	50-150	50-150
Capacity	Cooling (nominal) kW	56.00	61.50	67.00	73.00	77.50	85.00	90.00	95.00
	Heating (nominal) kW	63.00	69.00	77.50	82.50	90.00	95.00	100.00	106.00
Consumption	Cooling (nominal) kW	12.36	14.62	16.88	17.69	19.69	21.61	24.32	24.30
	Heating (nominal) kW	13.29	14.66	16.56	19.81	21.53	23.35	25.56	27.89
EER		4.53	4.21	3.97	4.13	3.94	3.93	3.70	3.91
COP		4.74	4.71	4.68	4.17	4.18	4.07	3.91	3.80
SEER		8.06	7.97	7.91	7.92	7.71	7.43	7.62	7.83
SCOP		4.76	4.76	4.81	4.78	4.82	4.71	4.63	4.72
Electrical power		3N ~400V 50 Hz	3N ~400V 50 Hz	3N ~400V 50 Hz	3N ~400V 50 Hz	3N ~400V 50 Hz	3N ~400V 50 Hz	3N ~400V 50 Hz	3N ~400V 50 Hz
Maximum current	A	38.0	42.0	46.0	51.5	55.5	57.0	62.0	67.0
Indoor/outdoor wiring section (shielded)	mm	2x0.75	2x0.75	2x0.75	2x0.75	2x0.75	2x0.75	2x0.75	2x0.75
Outside operating temperatures	Cooling (DB) °C	-10 to 52	-10 to 52	-10 to 52	-10 to 52	-10 to 52	-10 to 52	-10 to 52	-10 to 52
	Heating (WB) °C	-20 to 15	-20 to 15	-20 to 15	-20 to 15	-20 to 15	-20 to 15	-20 to 15	-20 to 15
Air flow	m3/h	26,280	26,280	26,280	32,700	32,700	34,860	36,300	41,280
Available pressure	Pa	30-60-80	30-60-80	30-60-80	30-60-80	30-60-80	30-60-80	30-60-80	30-60-80
N° fans		4	4	4	4	4	4	4	4
Sound pressure	dB(A)	62.00	62.50	63.00	66.00	66.00	66.00	67.00	68.00
Sound power	dB(A)	85.00	86.00	86.00	87.00	87.00	88.00	89.00	89.00
Pipe diameter	Liquid-low gas-high gas inches	5/8-7/8-7/8	5/8-7/8-1	5/8-7/8-1	3/4-1 1/4-1	3/4-1 1/4-1 1/8	3/4-1 1/4-1 1/8	3/4-1 1/4-1 1/8	3/4-1 1/4-1 1/8
N° and type of compressor		2 Scroll Inverters	2 Scroll Inverters	2 Scroll Inverters	3 Scroll Inverters	3 Scroll Inverters	3 Scroll Inverters	3 Scroll Inverters	4 Scroll Inverters
Refrigerant		R410A	R410A	R410A	R410A	R410A	R410A	R410A	R410A
Refrigerant charge	kg (m)	17.00	17.80	18.60	18.50	19.30	19.90	19.90	20.60
Dimensions (H x W x D)	mm	1,725x1,609x784	1,725x2,458x784	1,725x2,458x784	1,725x2,458x784	1,725x2,848x784	1,725x2,848x784	1,725x2,848x784	1,725x3,238x784
Weight	kg	556	560	564	647	651	666	676	753

Compatible controls and accessories:

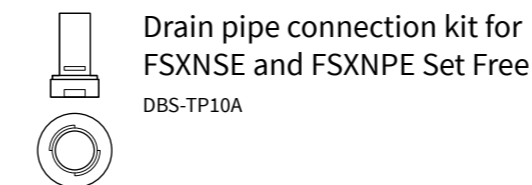

Outdoor unit			RAS-36FSXNPE	RAS-38FSXNPE	RAS-40FSXNPE	RAS-42FSXNPE	RAS-44FSXNPE	RAS-46FSXNPE	RAS-48FSXNPE	RAS-50FSXNPE	
Combination of modules			RAS-18FSXNPE RAS-18FSXNPE	RAS-12FSXNPE RAS-12FSXNPE RAS-14FSXNPE	RAS-12FSXNPE RAS-14FSXNPE	RAS-14FSXNPE RAS-14FSXNPE RAS-14FSXNPE	RAS-12FSXNPE RAS-14FSXNPE RAS-18FSXNPE	RAS-14FSXNPE RAS-14FSXNPE RAS-18FSXNPE	RAS-12FSXNPE RAS-18FSXNPE	RAS-14FSXNPE RAS-18FSXNPE	
Maximum number of connectable indoor units			64	64	64	64	64	64	64	64	
Capacity index *			%	50-150	50-150	50-150	50-150	50-150	50-150	50-150	
Capacity	Cooling (nominal)	kW	100.00	106.00	112.00	118.00	122.00	128.00	136.00	140.00	
	Heating (nominal)	kW	112.00	118.00	125.00	132.00	140.00	145.00	150.00	155.00	
Consumption	Cooling (nominal)	kW	25.58	28.14	31.08	34.01	32.36	35.29	34.65	37.10	
	Heating (nominal)	kW	29.95	26.42	29.12	31.81	34.20	36.41	38.09	40.27	
EER			3.91	3.77	3.60	3.47	3.77	3.63	3.92	3.77	
COP			3.74	4.47	4.29	4.15	4.09	3.98	3.94	3.85	
SEER			7.60	7.67	7.67	7.67	7.64	7.64	7.61	7.61	
SCOP			4.64	4.74	4.68	4.63	4.68	4.63	4.68	4.64	
Electrical power			3N ~400V 50 Hz	3N ~400V 50 Hz	3N ~400V 50 Hz	3N ~400V 50 Hz	3N ~400V 50 Hz	3N ~400V 50 Hz	3N ~400V 50 Hz	3N ~400V 50 Hz	
Maximum current			A	68.5	73.5	78.5	83.0	85.0	89.5	91.0	96.0
Indoor/outdoor wiring section (shielded)			mm	2x0.75	2x0.75	2x0.75	2x0.75	2x0.75	2x0.75	2x0.75	
Outside operating temperatures	Cooling (DB)	°C	-10 to 52	-10 to 52	-10 to 52	-10 to 52	-10 to 52	-10 to 52	-10 to 52	-10 to 52	
	Heating (WB)	°C	-20 to 15	-20 to 15	-20 to 15	-20 to 15	-20 to 15	-20 to 15	-20 to 15	-20 to 15	
Air flow			m3/h	43,440	40,860	42,300	43,740	49,440	56,580	58,020	
Available pressure			Pa	30-60-80	30-60-80	30-60-80	30-60-80	30-60-80	30-60-80	30-60-80	
N° fans				4	4	6	6	6	6	6	
Sound pressure			dB(A)	68.00	65.50	66.00	67.00	67.50	68.00	68.50	69.00
Sound power			dB(A)	89.00	89.00	89.00	90.00	90.00	90.00	90.00	90.00
Pipe diameter			Liquid-low gas-high gas	inches	3/4-1 1/2-1 1/8	3/4-1 1/2-1 1/4	3/4-1 1/2-1 1/4	3/4-1 1/2-1 1/4	3/4-1 1/2-1 1/4	3/4-1 1/2-1 1/4	
N° and type of compressor				4 Scroll Inverters	3 Scroll Inverters	3 Scroll Inverters	3 Scroll Inverters	4 Scroll Inverters	4 Scroll Inverters	5 Scroll Inverters	
Refrigerant				R410A	R410A	R410A	R410A	R410A	R410A	R410A	
Refrigerant charge			kg (m)	21.20	27.90	27.90	27.90	29.20	29.20	30.50	
Dimensions (H x W x D)			mm	1,725x3,238x784	1,725x3,697x784	1,725x3,697x784	1,725x3,697x784	1,725x4,087x784	1,725x4,477x784	1,725x4,477x784	
Weight			kg	768	856	866	876	958	968	1,050	

Outdoor unit			RAS-52FSXNPE	RAS-54FSXNPE	RAS-56FSXNPE	RAS-58FSXNPE	RAS-60FSXNPE	RAS-62FSXNPE	RAS-64FSXNPE	RAS-66FSXNPE	
Combination of modules			RAS-16FSXNPE RAS-18FSXNPE RAS-18FSXNPE	RAS-18FSXNPE RAS-18FSXNPE	RAS-12FSXNPE RAS-14FSXNPE RAS-18FSXNPE	RAS-12FSXNPE RAS-14FSXNPE RAS-18FSXNPE	RAS-14FSXNPE RAS-14FSXNPE RAS-16FSXNPE	RAS-14FSXNPE RAS-16FSXNPE RAS-16FSXNPE	RAS-16FSXNPE RAS-16FSXNPE RAS-16FSXNPE	RAS-16FSXNPE RAS-16FSXNPE RAS-16FSXNPE	
Maximum number of connectable indoor units			64	64	64	64	64	64	64	64	
Capacity index *			%	50-150	50-150	50-130	50-130	50-130	50-130	50-130	
Capacity	Cooling (nominal)	kW	145.00	150.00	157.00	162.00	167.00	174.00	179.00	184.00	
	Heating (nominal)	kW	160.00	165.00	176.00	181.00	188.00	196.00	202.00	207.00	
Consumption	Cooling (nominal)	kW	37.08	38.36	41.19	43.87	45.26	45.79	45.78	47.06	
	Heating (nominal)	kW	42.34	44.12	41.84	44.06	47.03	49.86	52.20	53.99	
EER			3.91	3.91	3.81	3.69	3.69	3.80	3.91	3.91	
COP			3.78	3.74	4.21	4.11	4.00	3.93	3.87	3.83	
SEER			7.75	7.60	7.65	7.64	7.91	8.03	8.15	7.98	
SCOP			4.70	4.64	4.70	4.67	4.73	4.78	4.83	4.77	
Electrical power			3N ~400V 50 Hz	3N ~400V 50 Hz	3N ~400V 50 Hz	3N ~400V 50 Hz	3N ~400V 50 Hz	3N ~400V 50 Hz	3N ~400V 50 Hz	3N ~400V 50 Hz	
Maximum current			A	101.0	103.0	109.0	114.0	122.0	127.0	132.0	134.0
Indoor/outdoor wiring section (shielded)			mm	2x0.75	2x0.75	2x0.75	2x0.75	2x0.75	2x0.75	2x0.75	
Outside operating temperatures	Cooling (DB)	°C	-10 to 52	-10 to 52	-10 to 52	-10 to 52	-10 to 52	-10 to 52	-10 to 52	-10 to 52	
	Heating (WB)	°C	-20 to 15	-20 to 15	-20 to 15	-20 to 15	-20 to 15	-20 to 15	-20 to 15	-20 to 15	
Air flow			m3/h	63,000	65,160	62,580	64,020	68,280	73,260	80,400	
Available pressure			Pa	30-60-80	30-60-80	30-60-80	30-60-80	30-60-80	30-60-80	30-60-80	
N° fans				6	6	8	8	8	8	8	
Sound pressure			dB(A)	70.00	70.00	68.50	68.50	70.00	70.50	71.00	71.00
Sound power			dB(A)	90.00	91.00	90.00	91.00	91.00	91.00	91.00	91.00
Pipe diameter			Liquid-low gas-high gas	inches	3/4-1 1/2-1 1/4	3/4-1 1/2-1 1/4	3/4-1 3/4	3/4-1 3/4	3/4-1 3/4	3/4-1 3/4	3/4-1 3/4
N° and type of compressor				6 Scroll Inverters	6 Scroll Inverters	5 Scroll Inverters	5 Scroll Inverters	6 Scroll Inverters	7 Scroll Inverters	8 Scroll Inverters	
Refrigerant				R410A	R410A	R410A	R410A	R410A	R410A	R410A	
Refrigerant charge			kg (m)	31.20	31.80	38.50	38.50	38.60	39.30	40.00	
Dimensions (H x W x D)			mm	1,725x4,867x784	1,725x4,867x784	1,725x5,326x784	1,725x5,326x784	1,725x5,716x784	1,725x6,106x784	1,725x6,496x784	
Weight			kg	1,137	1,152	1,240	1,250	1,322	1,399	1,476	

Outdoor unit			RAS-68FSXNPE	RAS-70FSXNPE	RAS-72FSXNPE
Combination of modules			RAS-16FSXNPE RAS-16FSXNPE RAS-18FSXNPE RAS-18FSXNPE	RAS-16FSXNPE RAS-18FSXNPE RAS-18FSXNPE RAS-18FSXNPE	RAS-18FSXNPE RAS-18FSXNPE RAS-18FSXNPE RAS-18FSXNPE
Maximum number of connectable indoor units			64	64	64
Capacity index *			%	50-130	50-130
Capacity	Cooling (nominal)	kW	190.00	196.00	201.00
	Heating (nominal)	kW	213.00	220.00	225.00
Consumption	Cooling (nominal)	kW	48.59	50.13	51.41
	Heating (nominal)	kW	56.05	58.37	60.16
EER			3.91	3.91	3.91
COP			3.80	3.77	3.74
SEER			7.83	7.71	7.60
SCOP			4.72	4.68	4.64
Electrical power			3N ~400V 50 Hz	3N ~400V 50 Hz	3N ~400V 50 Hz
Maximum current			A	135.0	137.0
Indoor/outdoor wiring section (shielded)			mm	2x0.75	2x0.75
Outside operating temperatures	Cooling (DB)	°C	-10 to 52	-10 to 52	-10 to 52
	Heating (WB)	°C	-20 to 15	-20 to 15	-20 to 15
Air flow			m3/h	82,560	84,720
Available pressure			Pa	30-60-80	30-60-80
N° fans				8	8
Sound pressure			dB(A)	71.00	71.00
Sound power			dB(A)	92.00	91.00
Pipe diameter			Liquid-low gas-high gas	inches	7/8-1 3/4
N° and type of compressor			8 Scroll Inverters	8 Scroll Inverters	8 Scroll Inverters
Refrigerant			R410A	R410A	R410A
Refrigerant charge			kg (m)	41.20	41.80
Dimensions (H x W x D)			mm	1,725x6,496x784	1,725x6,496x784
Weight			kg	1,506	1,521

Pricelist VRF Set Free Sigma High-Efficiency FSXNPE

Outdoor unit	Combinations	2-pipe multikits	3-pipe multikits	
VRF Set Free Sigma FSXNPE. Heat pump/ Heat recovery	RAS - 5FSXNPE	Base module	—	
	RAS - 6FSXNPE	Base module	—	
	RAS - 8FSXNPE	Base module	—	
	RAS - 10FSXNPE	Base module	—	
	RAS - 12FSXNPE	Base module	—	
	RAS - 14FSXNPE	Base module	—	
	RAS - 16FSXNPE	Base module	—	
	RAS - 18FSXNPE	Base module	—	
	RAS - 20FSXNPE	RAS - 10FSXNPE - RAS - 10FSXNPE	MC-20AN1	MC-20XN1
	RAS - 22FSXNPE	RAS - 10FSXNPE - RAS - 12FSXNPE	MC-20AN1	MC-20XN1
	RAS - 24FSXNPE	RAS - 12FSXNPE - RAS - 12FSXNPE	MC-20AN1	MC-20XN1
	RAS - 26FSXNPE	RAS - 10FSXNPE - RAS - 16FSXNPE	MC-21AN1	MC-20XN1
	RAS - 28FSXNPE	RAS - 12FSXNPE - RAS - 16FSXNPE	MC-21AN1	MC-30XN1
	RAS - 30FSXNPE	RAS - 12FSXNPE - RAS - 18FSXNPE	MC-21AN1	MC-30XN1
	RAS - 32FSXNPE	RAS - 14FSXNPE - RAS - 18FSXNPE	MC-21AN1	MC-30XN1
	RAS - 34FSXNPE	RAS - 16FSXNPE - RAS - 18FSXNPE	MC-21AN1	MC-30XN1
	RAS - 36FSXNPE	RAS - 18FSXNPE - RAS - 18FSXNPE	MC-21AN1	MC-30XN1
	RAS - 38FSXNPE	RAS - 12FSXNPE - RAS - 12FSXNPE - RAS - 14FSXNPE	MC-30AN1	MC-30XN1
	RAS - 40FSXNPE	RAS - 12FSXNPE - RAS - 14FSXNPE - RAS - 14FSXNPE	MC-30AN1	MC-30XN1
	RAS - 42FSXNPE	RAS - 14FSXNPE - RAS - 14FSXNPE - RAS - 14FSXNPE	MC-30AN1	MC-30XN1
RAS - 44FSXNPE	RAS - 12FSXNPE - RAS - 14FSXNPE - RAS - 18FSXNPE	MC-30AN1	MC-30XN1	
RAS - 46FSXNPE	RAS - 14FSXNPE - RAS - 14FSXNPE - RAS - 18FSXNPE	MC-30AN1	MC-30XN1	
RAS - 48FSXNPE	RAS - 12FSXNPE - RAS - 18FSXNPE - RAS - 18FSXNPE	MC-30AN1	MC-30XN1	
RAS - 50FSXNPE	RAS - 14FSXNPE - RAS - 18FSXNPE - RAS - 18FSXNPE	MC-30AN1	MC-30XN1	
RAS - 52FSXNPE	RAS - 16FSXNPE - RAS - 18FSXNPE - RAS - 18FSXNPE	MC-30AN1	MC-30XN1	
RAS - 54FSXNPE	RAS - 18FSXNPE - RAS - 18FSXNPE - RAS - 18FSXNPE	MC-30AN1	MC-30XN1	
VRF Set Free Sigma FSXNPE. Heat pump	RAS - 56FSNPE	RAS - 12FSNPE - RAS - 12FSNPE - RAS - 14FSNPE - RAS - 18FSNPE	MC-NP40SA	
	RAS - 58FSNPE	RAS - 12FSNPE - RAS - 14FSNPE - RAS - 14FSNPE - RAS - 18FSNPE	MC-NP40SA	
	RAS - 60FSNPE	RAS - 14FSNPE - RAS - 14FSNPE - RAS - 16FSNPE - RAS - 16FSNPE	MC-NP40SA	
	RAS - 62FSNPE	RAS - 14FSNPE - RAS - 16FSNPE - RAS - 16FSNPE - RAS - 16FSNPE	MC-NP40SA	
	RAS - 64FSNPE	RAS - 16FSNPE - RAS - 16FSNPE - RAS - 16FSNPE - RAS - 16FSNPE	MC-NP40SA	
	RAS - 66FSNPE	RAS - 16FSNPE - RAS - 16FSNPE - RAS - 16FSNPE - RAS - 18FSNPE	MC-NP40SA	
	RAS - 68FSNPE	RAS - 16FSNPE - RAS - 16FSNPE - RAS - 18FSNPE - RAS - 18FSNPE	MC-NP40SA	
	RAS - 70FSNPE	RAS - 16FSNPE - RAS - 18FSNPE - RAS - 18FSNPE - RAS - 18FSNPE	MC-NP40SA	
RAS - 72FSNPE	RAS - 18FSNPE - RAS - 18FSNPE - RAS - 18FSNPE - RAS - 18FSNPE	MC-NP40SA		

2-pipe splitter

Name
E102SN4
E-162SN4
E-242SN3
E-302SN3

2-pipe manifold

Name
MH-84AN1
MH-108AN

3-pipe splitter

Name
E-52XN3
E-102XN3
E-162XN3
E-242XN3
E-322XN3

3-pipe manifold

Name
MH-108XN

CH-BOX

Type	Individual CH BOX		Multiple CH-BOX			
	CH-AP160SSX	CH-AP280SSX	CH-AP04MSSX	CH-AP08MSSX	CH-AP12MSSX	CH-AP16MSSX
Model	CH-AP160SSX	CH-AP280SSX	CH-AP04MSSX	CH-AP08MSSX	CH-AP12MSSX	CH-AP16MSSX
Total capacity (kW)	16	28	44.8	85	85	85
Number of outputs	1	1	4	8	12	16
Max capacity per output (kW)	16		16	16	16	16
Maximum number of connectable units per output	7	8	6	6	6	6
Dimensions (height-width-depth) (mm)	191 x 301 x 214	191 x 301 x 214	260 x 303 x 352	260 - 543 - 352	260 - 783 - 352	260 - 1023 - 352
Weight (kg)	6	6	14	25	36	47

Multiple CH-Box



CH-AP04MSSX



CH-AP08MSSX



CH-AP12MSSX



CH-AP16MSSX

Individual CH-Box



CH-AP160SSX
CH-AP280SSX

Cassette



- Compact dimensions (RCIM model): 285x570 mm.
- Energy saving with presence sensor.
- Greater comfort thanks to the design of the slats with independent control.
- High-performance exchanger.
- Drainage pump with direct current motor.

Ducts



- Easy installation in low false ceilings with low silhouette ducts: 197 mm.
- Condensate pump: allows installation up to 850 mm above the unit.
- Lower air return in the mini and medium pressure ducts.
- Separate air filter in three parts for easy maintenance on both sides with high pressure ducts.

Wall-mounted

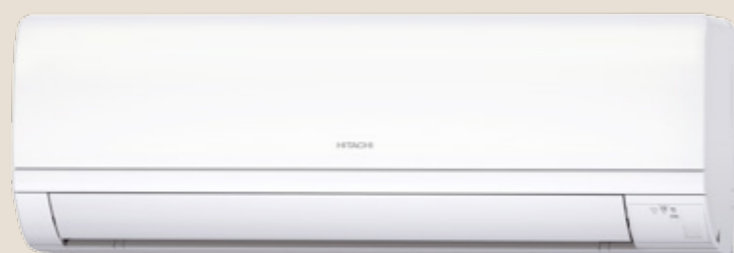

- Prevents noise thanks to its expansion valve outside the room (optional).
- 4 air flow speeds.
- Centralised control without the need for wired thermostats.

Console



- Compact design: just 220 mm deep, occupying minimum floorspace.
- Optional remote control that can be integrated in the unit enclosure under the casing cover.

Ceiling-mounted



- Improved air distribution throughout the room thanks to the optimised louvre.
- 4 air flow speeds.
- Energy savings.

DX-Kit



- Simplifies the installation of third party AHUs and Air Curtains without the need to install hydraulic systems.
- Option to regulate capacity in accordance with Inlet Air Temperature, Outlet Air Temperature, Incremental reference duty control and Absolute reference control depending on application.

Hydro Free



- Ideal for installations that need hot water production, pool heating, fan coils, AHUs or underfloor heating.
- Operation in heat pump and heat recovery.
- Easy installation and maintenance, plug & play. All components are built-in.
- High temperature and low temperature models available

Benefits VRF Indoor units

1 Energy saving with presence sensor

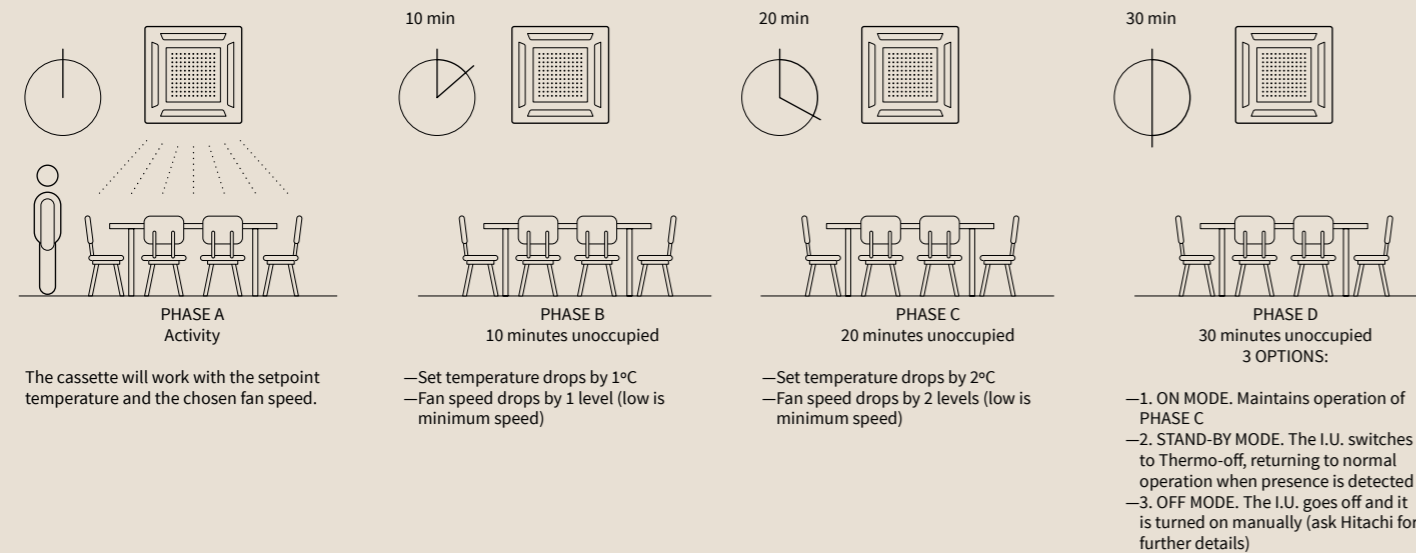

In VRF indoor units, such as cassettes, ceiling-mounted and ducts, the presence sensor allows the unit to be adapted in accordance with room occupancy. If the unit is installed in a room where people are constantly coming and going, it regulates operation automatically as if there were nobody present, without the need to turn the indoor unit off by hand. This reduces unnecessary consumption and generates significant energy savings.

2 Tailor-made units thanks to their compact designs

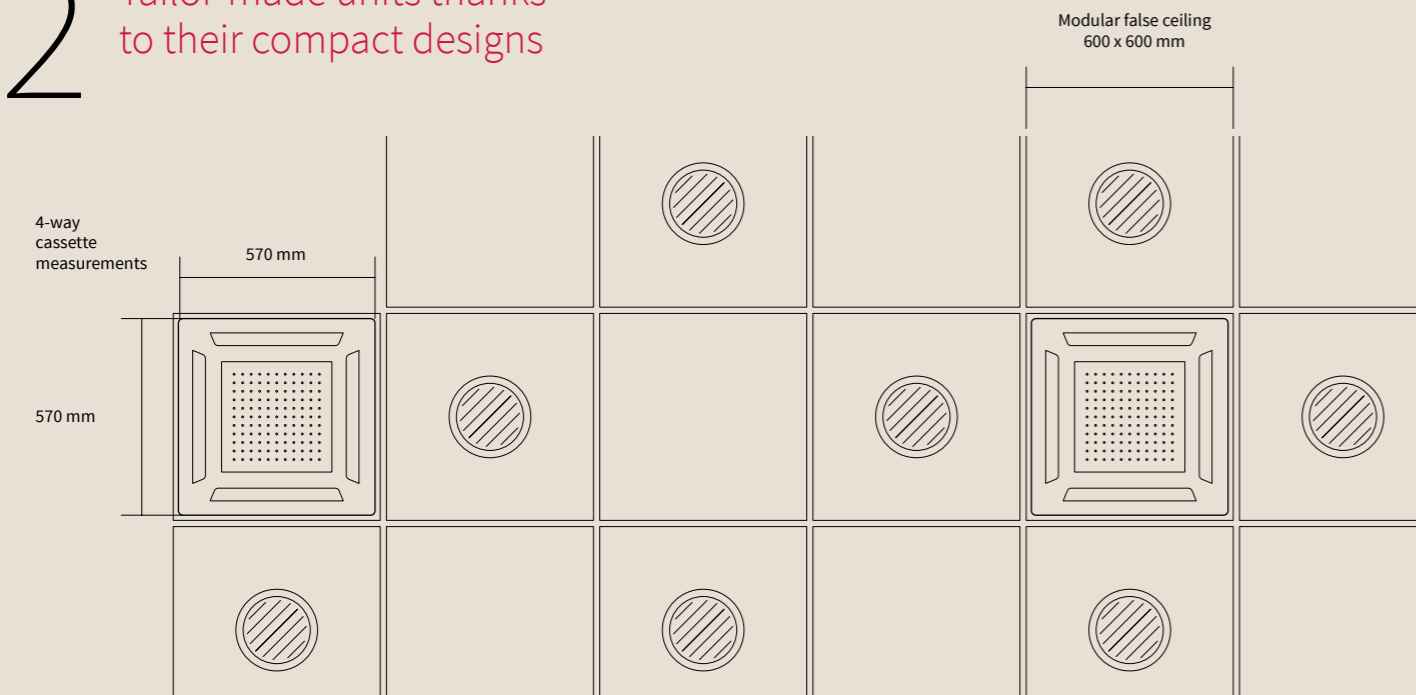

The RCIM-FSN4E, a 4-way cassette, has the perfect dimensions: 285 mm high by 570 mm wide, for installation in standard modular false ceiling openings measuring 600x600 mm. This makes it the ideal system for installation

in confined spaces, adapting to these requirements without having to remove any light fittings. Moreover, the console-type units are only 220 mm deep and can be installed on a wall, taking up minimal floorspace.

3 More economical thanks to the built-in condensate pump

The duct units have a built-in condensate pump, allowing them to be installed up to 850 mm above the unit. The pump is enabled automatically when the accumulated water level is excessive.

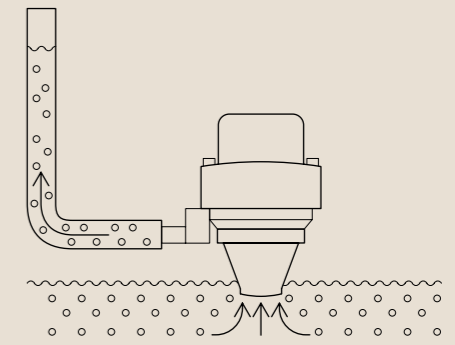

4 Low noise level with the expansion valve

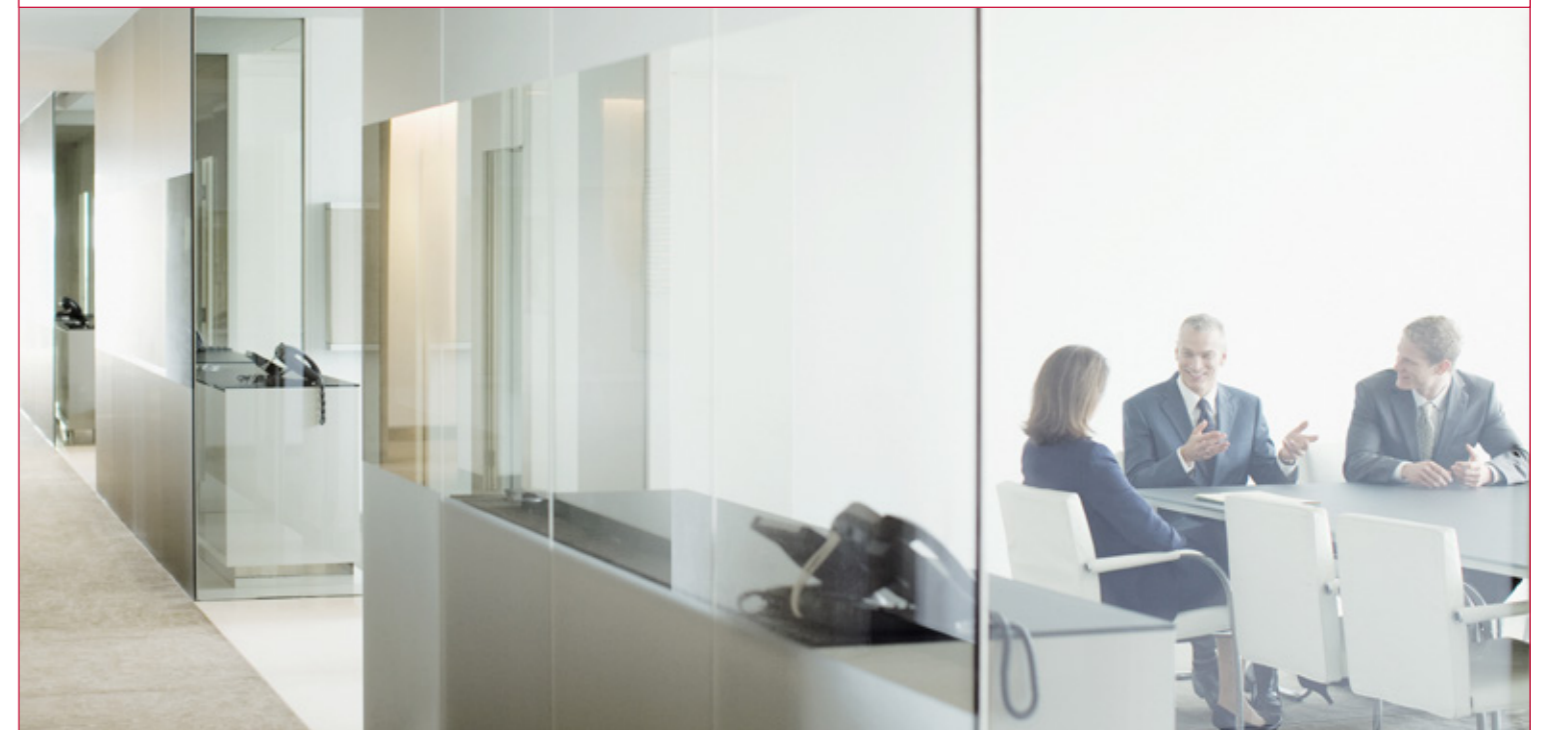

In wall-mounted indoor units, the expansion valve can be installed outside the room to avoid any noise indoors.

5 Maximum comfort thanks to the optimised louvres with 4 air flow speeds

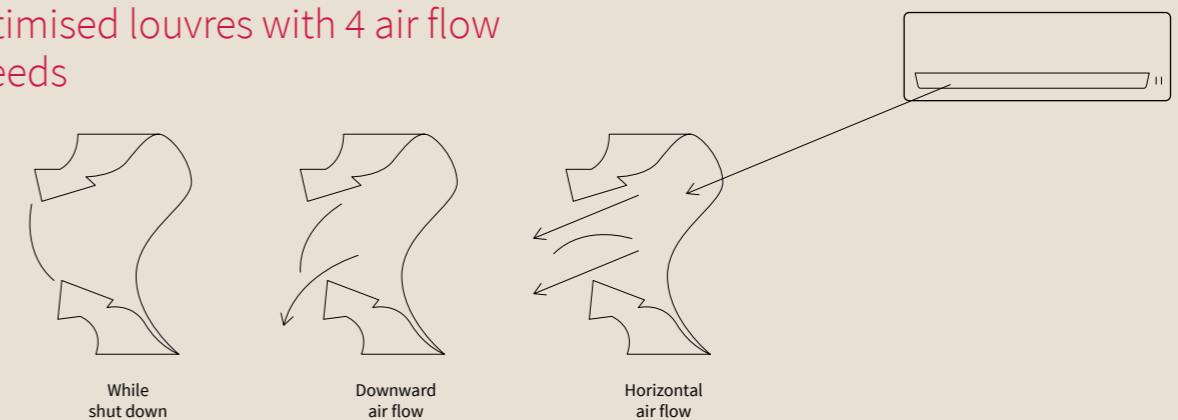

The ceiling-mounted units have louvres shaped to distribute the air around the room, ensuring maximum comfort throughout the air conditioned zone. This ensures a uniform thermal sensation for all people in the room, whether they are next to the indoor unit or far away. Moreover, "High H" speed covers the entire room, even in high ceilings, removing the need to adjust speed with the remote control.

Cassettes

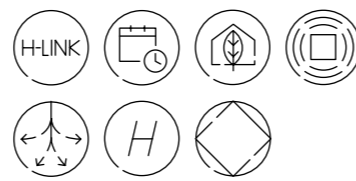

Smallest capacity on the market

The RCIM indoor unit has the lowest capacity on the market, with **just 1.1 kW in cooling operation**. This makes it ideal for buildings with low energy demand, such as Passivhaus buildings.

New air flow

Perfect for rooms with high ceilings, thanks to a new upper air flow.

Easy installation in standard modular false ceiling openings measuring 600x600 mm

The RCIM is perfectly sized for installation in confined spaces: just 285 mm high and **570 mm wide**. It can therefore adapt to the 600x600 mm standard European panel without interfering with the other panels or installations.

Individual air off temperature control

Each fan coil can have its own tailored air off comfort setting easily changeable by local control for maximum comfort.

More comfort thanks to independent louvre control

All cassette units have had the louvres designed to prevent air turbulence and reduce load loss. This renewed design enhances the **COANDA** effect, avoiding cold air flows and improving comfort. (Fig. 1)

Energy savings of up to 14 % thanks to the presence sensor

The built-in presence detector adapts consumption to occupancy in the room where it is installed, keeping the environment comfortable and generating important energy savings.

Fig. 1
Adjusting the individual control of each louvre

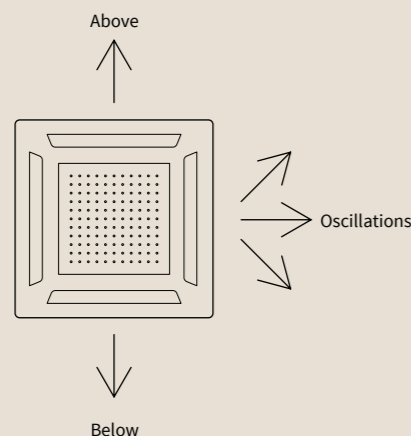

Indoor units

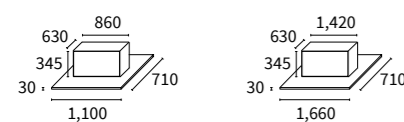

RCD-0.8FSN3
RCD-1.0FSN3
RCD-1.5FSN3
RCD-2.0FSN3
RCD-2.5FSN3
RCD-3.0FSN3

RCD-4.0FSN3
RCD-5.0FSN3
RCD-6.0FSN3

2-way cassette

Indoor unit			RCD-0.8FSN3	RCD-1.0FSN3	RCD-1.5FSN3	RCD-2.0FSN3	RCD-2.5FSN3	RCD-3.0FSN3	RCD-4.0FSN3	RCD-5.0FSN3	RCD-6.0FSN3
Adjustable power			-	-	1.30-1.50	1.80-2.00	2.30-2.50	-	-	-	-
Nominal capacity (VRF SET FREE)	Cooling	kW	2.20	2.80	4.00	5.60	7.10	8.00	11.20	14.00	16.00
	Heating	kW	2.50	3.20	4.80	6.30	8.50	9.00	12.50	16.00	18.00
Nominal capacity (VRF IVX)	Cooling	kW	2.00	2.50	3.60	5.00	5.60	7.10	10.00	12.50	14.00
	Heating	kW	2.20	2.80	4.00	5.60	6.30	8.00	11.20	14.00	16.00
Air flow (Low - Medium - High - Very high)		m ³ /h	390-450-540-600	420-510-570-660	600-690-780-900	630-750-870-990	750-870-990-1.110-1.100	750-960-1.110-1.260	1.200-1.380-1.590-1.800	1.260-1.620-1.860-2.100	1.440-1.710-1.950-2.220
Sound pressure (Low - Medium - High - Very high)		dB(A)	27-28-29-30	27-28-29-31	30-31-34-37	30-33-36-39	33-36-39-42	33-38-42-45	34-37-40-43	35-41-44-47	39-42-45-48
Sound power (High)		dB(A)	44	46	49	51	52	55	55	55	59
Pipe diameter	Liquid-gas	inches	1/4-1/2	1/4-1/2	1/4-1/2	1/4-1/2	3/8-5/8	3/8-5/8	3/8-5/8	3/8-5/8	3/8-5/8
Condensate pipe diameter (out)		mm	32	32	32	32	32	32	32	32	32
Cassette dimensions	Height	mm	345	345	345	345	345	345	345	345	345
	Width	mm	860	860	860	860	860	860	1,420	1,420	1,420
	Depth	mm	630	630	630	630	630	630	630	630	630
Cassette weight		kg	23.0	23.0	25.0	25.0	25.0	25.0	39.0	39.0	39.0
Panel dimensions	Height	mm	30	30	30	30	30	30	30	30	30
	Width	mm	1,100	1,100	1,100	1,100	1,100	1,100	1,660	1,660	1,660
	Depth	mm	710	710	710	710	710	710	710	710	710
Panel weight		kg	7.5	7.5	7.5	7.5	7.5	7.5	10.5	10.5	10.5
Condensate pump			Included	Included	Included	Included	Included	Included	Included	Included	Included
Maximum condensate height		mm	850	850	850	850	850	850	850	850	850
Electrical power			1 ~230V 50Hz	1 ~230V 50Hz	1 ~230V 50Hz	1 ~230V 50Hz	1 ~230V 50Hz	1 ~230V 50Hz	1 ~230V 50Hz	1 ~230V 50Hz	1 ~230V 50Hz

Compatible controls and accessories:



Wired control with programmer
PC-ARFP1E

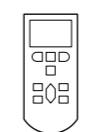

Wireless remote control
PC-AWR
(See model in the controls section)

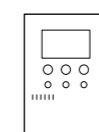

Simplified remote control
PC-ARH

Others

- PS-MSK2 presence sensor kit. Compatible with RCI-FSN4
- SOR-NEC presence sensor kit. Compatible with RCIM-FSN4E
- SOR-NED presence sensor kit. Compatible with RCD-FSN3
- Optional functions connector (5 units) PCC- 1A



4-Way Cassette (600 x 600 FSN4E)

Indoor unit			RCIM-0.4FSN4E	RCIM-0.6FSN4E	RCIM-0.8FSN4E	RCIM-1.0FSN4E	RCIM-1.5FSN4E	RCIM-2.0FSN4E	RCIM-2.5FSN4E
Adjustable power			-	-	0.60-0.80	-	1.30-1.50	1.80-2.00	2.30-2.50
Nominal capacity (VRF SET FREE)	Cooling	kW	1.10	1.70	2.20	2.80	4.00	5.60	7.10
	Heating	kW	1.30	1.90	2.50	3.20	4.80	6.30	8.50
Nominal capacity (VRF IVX)	Cooling	kW	-	-	2.00	2.50	3.60	5.00	5.60
	Heating	kW	-	-	2.20	2.80	4.00	5.60	6.30
Air flow (Low - Medium - High - Very high)		m ³ /h	360-414-468-510	360-450-510-600	360-480-570-660	360-510-600-720	420-570-660-780	480-600-720-900	600-720-840-960
Sound pressure (Low - Medium - High - Very high)		dB(A)	24.5-25-27-29	24.5-28-30-34	24.5-29-33-36	24.5-30-34-38	27.5-33-37-41	31-35-39-45	35-39-43-47
Sound power		dB(A)	43	47	50	51	54	56	60
Pipe diameter	Liquid-gas	inches	1/4-1/2	1/4-1/2	1/4-1/2	1/4-1/2	1/4-1/2	1/4-1/2	3/8-5/8
Condensate pipe diameter (out)		mm	32	32	32	32	32	32	32
Cassette dimensions	Height	mm	285	285	285	285	285	285	285
	Width	mm	570	570	570	570	570	570	570
	Depth	mm	570	570	570	570	570	570	570
Cassette weight		kg	16.0	16.0	16.0	16.0	16.0	17.0	17.0
Panel dimensions	Height	mm	30	30	30	30	30	30	30
	Width	mm	620	620	620	620	620	620	620
	Depth	mm	620	620	620	620	620	620	620
Panel weight		kg	2.5	2.5	2.5	2.5	2.5	2.5	2.5
Condensate pump			Included	Included	Included	Included	Included	Included	Included
Maximum condensate height		mm	850	850	850	850	850	850	850
Electrical power			1 ~230V 50Hz	1 ~230V 50Hz	1 ~230V 50Hz	1 ~230V 50Hz	1 ~230V 50Hz	1 ~230V 50Hz	1 ~230V 50Hz

4-Way Cassette 800 X 800 RCI Premium

Indoor unit			RCI-1.0FSN4	RCI-1.5FSN4	RCI-2.0FSN4	RCI-2.5FSN4	RCI-3.0FSN4	RCI-4.0FSN4	RCI-5.0FSN4	RCI-6.0FSN4
Adjustable power			-	1.30-1.50	1.80-2.00	2.30-2.50	-	-	-	-
Nominal capacity (VRF SET FREE)	Cooling	kW	2.80	4.00	5.60	7.10	8.00	11.20	14.00	16.00
	Heating	kW	3.20	4.80	6.30	8.50	9.00	12.50	16.00	18.00
Nominal capacity (VRF IVX)	Cooling	kW	2.50	3.60	5.00	5.60	7.10	10.00	12.50	14.00
	Heating	kW	2.80	4.00	5.60	6.30	8.00	11.20	14.00	16.00
Air flow (Low - Medium - High - Very high)		m ³ /h	540-660-780-900	660-840-1.020-1.260	660-840-1.020-1.320	840-1.080-1.380-1.620	840-1.080-1.380-1.620	1.200-1.440-1.860-2.220	1.260-1.560-1.980-2.220	1.320-1.680-2.100-2.220
Sound pressure (Low - Medium - High - Very high)		dB(A)	27-28-30-33	27-30-31-35	27-30-32-37	28-32-36-42	28-32-36-42	33-39-43-48	35-40-45-48	37-41-46-48
Sound power		dB(A)	52	53	55	56	57	64	64	65
Pipe diameter	Liquid-gas	inches	1/4-1/2	1/4-1/2	1/4-1/2	3/8-5/8	3/8-5/8	3/8-5/8	3/8-5/8	3/8-5/8
Condensate pipe diameter (out)		mm	32	32	32	32	32	32	32	32
Cassette dimensions	Height	mm	248	248	248	248	298	298	298	298
	Width	mm	840	840	840	840	840	840	840	840
	Depth	mm	840	840	840	840	840	840	840	840
Cassette weight		kg	20.0	21.0	21.0	22.0	26.0	26.0	26.0	26.0
Panel dimensions	Height	mm	40	40	40	40	40	40	40	40
	Width	mm	950	950	950	950	950	950	950	950
	Depth	mm	950	950	950	950	950	950	950	950
Panel weight		kg	6.5	6.5	6.5	6.5	6.5	6.5	6.5	6.5
Condensate pump			Included	Included	Included	Included	Included	Included	Included	Included
Maximum condensate height		mm	850	850	850	850	850	850	850	850
Electrical power			1 ~230V 50Hz	1 ~230V 50Hz	1 ~230V 50Hz	1 ~230V 50Hz	1 ~230V 50Hz	1 ~230V 50Hz	1 ~230V 50Hz	1 ~230V 50Hz

Indoor units

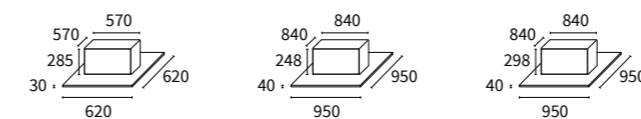

- RCIM-0.4FSN4E
 - RCIM-0.6FSN4E
 - RCIM-0.8FSN4E
 - RCIM-1.0FSN4E
 - RCIM-1.5FSN4E
 - RCIM-2.0FSN4E
 - RCIM-2.5FSN4E
- RCI-1.0FSN4
 - RCI-1.5FSN4
 - RCI-2.0FSN4
 - RCI-2.5FSN4
- RCI-3.0FSN4
 - RCI-4.0FSN4
 - RCI-5.0FSN4
 - RCI-6.0FSN4

Ducts

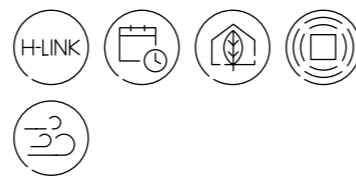
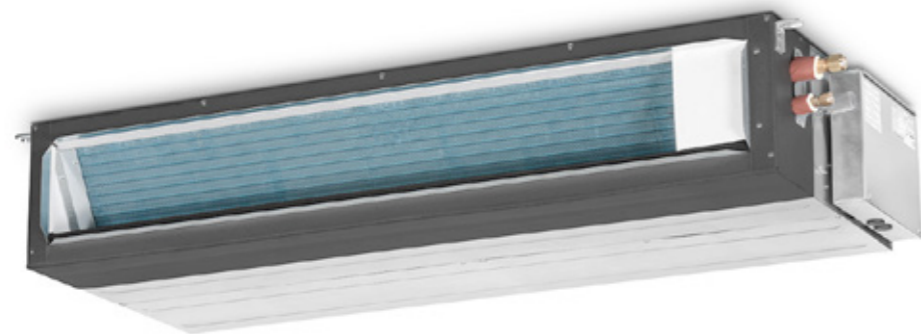

With condensate pump

The RPIM (0.6-1.5) FSN4E-DU systems have a built-in condensate pump, with a drain pump to raise condensate up to 850 mm above the unit. The pump is enabled automatically when the accumulated water level is excessive.

Individual air off temperature control

Each fan coil can have its own tailored air off comfort setting easily changeable by local control for maximum comfort.

Easy installation and maintenance

- Access in the duct units is quick and easy:
- The electronic board is accessed from outside the unit.
 - The filter does not have to be removed, and there is no need for additional access hatches. (Fig. 1)
 - The cooling and drainage connections are located at the rear.

Fig. 1b

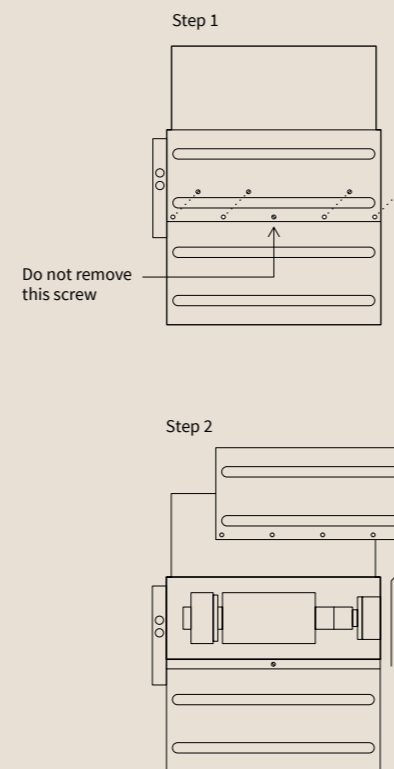
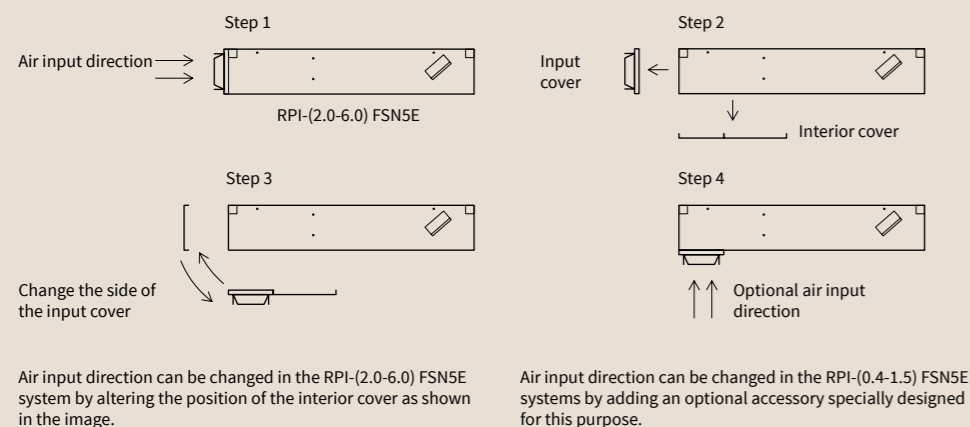
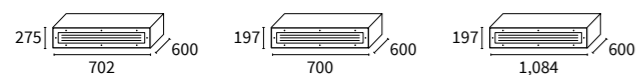

Fig. 1a



Indoor units



RPIM-0.6FSN4E-DU
RPIM-0.8FSN4E-DU
RPIM-1.0FSN4E-DU
RPIM-1.5FSN4E-DU

RPI-0.4FSN5E

RPI-0.6FSN5E
RPI-0.8FSN5E
RPI-1.0FSN5E
RPI-1.5FSN5E

Mini ducts

		RPIM-0.6FSN4E-DU	RPIM-0.8FSN4E-DU	RPIM-1.0FSN4E-DU	RPIM-1.5FSN4E-DU
Adjustable power		-	0.60-0.80	-	1.30-1.50
Nominal capacity (VRF SET FREE)	Cooling	kW	1.70	2.20	2.80
	Heating	kW	1.90	2.50	3.20
Nominal capacity (VRF IVX)	Cooling	kW	-	2.00	2.50
	Heating	kW	-	2.20	2.80
Nominal static pressure (Min/Max)	Pa	20 (0-35)	32 (0-50)	32 (0-50)	27 (0-58)
Air Flow (Low - Medium - High)	m3/h	330-372-420	330-408-480	330-408-480	480-540-600
Sound pressure (Low - Medium - High)	dB(A)	25-28-28	27-29-29	27-29-29	28-30-30
Sound power (High)	dB(A)	49	50	50	51
Pipe diameter	Liquid-gas	inches	1/4-1/2	1/4-1/2	1/4-1/2
Condensate pipe diameter (out)		mm	25	25	25
Duct dimensions	Height	mm	275	275	275
	Width	mm	702	702	702
	Depth	mm	600	600	600
Duct weight		kg	26.0	26.0	26.0
Condensate pump			Optional	Optional	Optional
Maximum condensate height		mm	850	850	850
Electrical power			1 ~230V 50Hz	1 ~230V 50Hz	1 ~230V 50Hz

Low height ducts

		RPI-0.4FSN5E	RPI-0.6FSN5E	RPI-0.8FSN5E	RPI-1.0FSN5E	RPI-1.5FSN5E
Adjustable power		-	-	0.60-0.80	-	1.30-1.50
Nominal capacity (VRF SET FREE)	Cooling	kW	1.10	1.70	2.20	2.80
	Heating	kW	1.30	1.90	2.50	3.20
Nominal capacity (VRF IVX)	Cooling	kW	-	-	2.00	2.50
	Heating	kW	-	-	2.20	2.80
Nominal static pressure (Min/Max)	Pa	25 (0-30)	20 (0-30)	32 (0-50)	32 (0-50)	27 (0-50)
Air flow (Low - Medium - High)	m3/h	336-354-384	330-372-420	378-432-480	378-432-480	480-540-600
Sound pressure (Low - Medium - High)	dB(A)	27-29-32	27-30-32	29-31-33	29-31-33	29-31-34
Sound power (High)	dB(A)	50	50	52	52	53
Pipe diameter	Liquid-gas	inches	1/4-1/2	1/4-1/2	1/4-1/2	1/4-1/2
Condensate pipe diameter (out)		mm	32	32	32	32
Duct dimensions	Height	mm	197	197	197	197
	Width	mm	700	1,084	1,084	1,084
	Depth	mm	600	600	600	600
Duct weight		kg	18.0	29.0	29.0	30.0
Condensate pump			Included	Included	Included	Included
Maximum condensate height		mm	850	850	850	850
Electrical power			1 ~230V 50Hz	1 ~230V 50Hz	1 ~230V 50Hz	1 ~230V 50Hz

Compatible controls and accessories:



Wired control with programmer
PC-ARFP1E

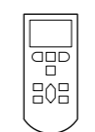

Wireless remote control
PC-AWR
(See model in the controls section)

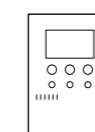

Simplified remote control
PC-ARH

Others

- SOR-MSK presence sensor kit. Compatible with RPI-(0.4-3.0)FSN5E
- THM-R2AE remote thermostat accessory. Compatible with RPI:
- Optional functions connector (5 units) PCC-1A
- D-ICA15 input change accessory. Compatible with RPI-(0.6-1.5)FSN5E

Medium pressure ducts

			RPI-2.0FSN5E	RPI-2.5FSN5E	RPI-3.0FSN5E	RPI-4.0FSN5E	RPI-5.0FSN5E	RPI-6.0FSN5E
Adjustable power			1.80-2.00	2.30-2.50	-	-	-	-
Nominal capacity (VRF SET FREE)	Cooling	kW	5.60	7.10	8.00	11.20	14.00	16.00
	Heating	kW	6.30	8.50	9.00	12.50	16.00	18.00
Nominal capacity (VRF IVX)	Cooling	kW	5.00	5.60	7.10	10.00	12.50	14.00
	Heating	kW	5.60	6.30	8.00	11.20	14.00	16.00
Available pressure (range)			30 (0-120)	30 (0-125)	30 (0-125)	45 (0-120)	50 (0-140)	50 (0-140)
Air flow (Low - Medium - High)			600-750-960	780-960-1.140	960-1.140-1.320	1.500-1.680-1.800	1.740-1.920-2.100	1.800-1.980-2.160
Sound pressure (Low - Medium - High)			27-29-29	28-30-30	29-31-31	32-35-37	33-35-38	33-36-39
Sound power (High)			55	56	57	62	65	66
Pipe diameter			Liquid-gas	inches	1/4-5/8	3/8-5/8	3/8-5/8	3/8-5/8
Condensate pipe diameter (out)			mm	32	32	32	32	32
Duct dimensions	Height	mm	275	275	275	275	275	275
	Width	mm	1,084	1,084	1,084	1,474	1,474	1,474
	Depth	mm	600	600	600	600	600	600
Duct weight			kg	35.0	36.0	36.0	48.0	48.0
Condensate pump				Included	Included	Included	Included	Included
Maximum condensate height			mm	850	850	850	850	850
Electrical power				1 ~230V 50Hz	1 ~230V 50Hz	1 ~230V 50Hz	1 ~230V 50Hz	1 ~230V 50Hz

High pressure ducts

			RPI-8.0FSN3	RPI-10.0FSN3E	RPI-16.0FSN3PE	RPI-20.0FSN3PE	
Adjustable power			-	-	-	-	
Nominal capacity (VRF SET FREE)	Cooling	kW	22.40	28.00	45.00	56.00	
	Heating	kW	25.00	31.00	50.00	63.00	
Nominal capacity (VRF IVX)	Cooling	kW	20.00	25.00	-	-	
	Heating	kW	22.40	28.00	-	-	
Available pressure (range)			180 (140-220)	180 (140-220)	180 (140-220)	180 (140-220)	
Air flow (Low - Medium - High)			3.570-3.960-3.960	4.056-4.500-4.500	7.200-7.920	8.220-9.000	
Sound pressure (Low - Medium - High)			51-54-54	52-55-55	53-56	54-57	
Sound power (High)			77	78	79	80	
Pipe diameter			Liquid-gas	inches	3/8-3/4	3/8-7/8	2x 3/8-7/8
Condensate pipe diameter (out)			mm	25	25	2 x25	
Duct dimensions	Height	mm	432	432	846	846	
	Width	mm	1,592	1,592	1,592	1,592	
	Depth	mm	600	600	600	600	
Duct weight			kg	85.0	87.0	171.0	
Condensate pump				Not included	Not included	Not included	
Electrical power				1 ~230V 50Hz	1 ~230V 50Hz	1 ~230V 50Hz	

Indoor units



RPI-2.0FSN5E
RPI-2.5FSN5E
RPI-3.0FSN5E

RPI-4.0FSN5E
RPI-5.0FSN5E
RPI-6.0FSN5E

RPI-8.0FSN3
RPI-10.0FSN3E

RPI-16.0FSN3PE
RPI-20.0FSN3PE

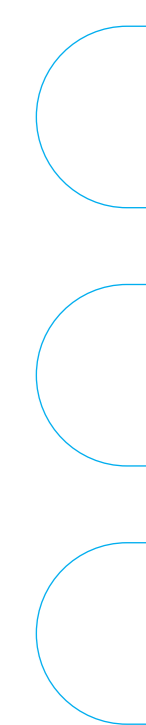

Wall-mounted

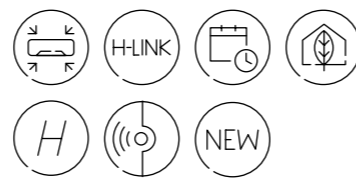

Wall-mounted



Centralised control

Units can be group controlled with a mixture of wired and wireless controllers. (Fig. 1)

Quieter units

In wall-mounted indoor units, the expansion valve can be installed outside to avoid any noise indoors.

4 air flow speeds

The "HIGH", "MEDIUM" and "LOW" air flow volumes have been supplemented with "HIGH H" in order to cover the whole room, even with very high ceilings.

Easy installation and maintenance

In wall-mounted units, there is no need to remove the front panel in order to handle the wiring and adjust the DIP switches.

Fig. 1

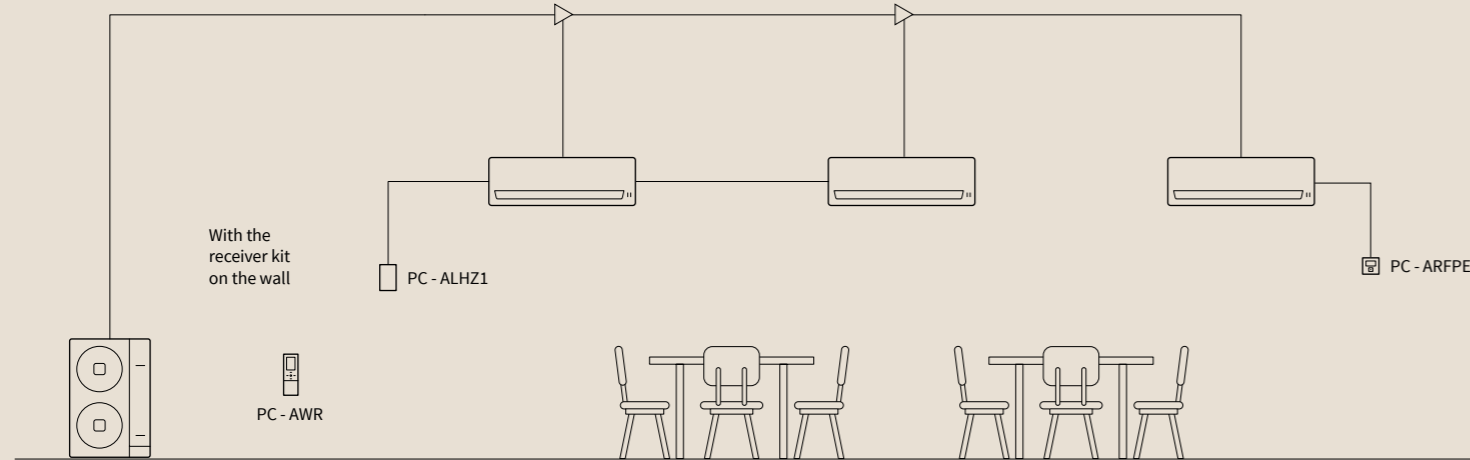

Indoor units

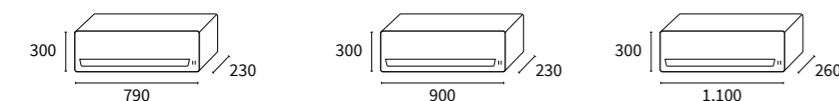

- RPK-0.4 FSN4M
- RPK-0.6 FSN4M
- RPK-2.0 FSN4M
- RPK-0.4FSNH4M
- RPK-0.6FSNH4M
- RPK-2.5 FSN4M
- RPK-0.8 FSN4M
- RPK-0.8FSNH4M
- RPK-3.0 FSN4M
- RPK-1.5 FSN4M
- RPK-1.5FSNH4M
- RPK-4.0 FSN4M

Wall-mounted with built-in expansion valve

		RPK-0.4 FSN4M	RPK-0.6 FSN4M	RPK-0.8 FSN4M	RPK-1.0 FSN4M	RPK-1.5 FSN4M	RPK-2.0 FSN4M	RPK-2.5 FSN4M	RPK-3.0 FSN4M	RPK-4.0 FSN4M
Adjustable power		-	-	0.60-0.80	1.00-1.30	-	1.80-2.00	2.30-2.50	-	-
Nominal capacity (VRF SET FREE)	Cooling kW	1.10	1.70	2.20	2.80	4.00	5.60	7.10	8.00	11.20
	Heating kW	1.30	1.90	2.50	3.20	4.80	6.30	8.50	9.00	12.50
Nominal capacity (VRF IVX)	Cooling kW	-	-	2.00	2.50	3.60	5.00	5.60	7.10	10.00
	Heating kW	-	-	2.20	2.80	4.00	5.60	6.30	8.00	11.20
Air flow (Low - Medium - High - Very high)	m3/h	360-402-438-450	360-420-450-480	390-420-480-600	390-420-480-600	450-540-660-840	570-660-780-870	720-840-990-1.110	750-930-1.050-1.200	870-1.050-1.200-1.380
Sound pressure (Low - Medium - High - Very high)	dB(A)	29-30-31-32	29-31-32-35	30-32-35-39	30-32-35-39	33-36-40-46	31-34-37-40	35-38-42-45	35-40-44-47	39-44-48-51
Sound power (High)	dB(A)	49	49	53	53	58	55	60	63	65
Pipe diameter	Liquid-gas inches	1/4-1/2	1/4-1/2	1/4-1/2	1/4-1/2	1/4-1/2	1/4-1/2	3/8-5/8	3/8-5/8	3/8-5/8
Condensate pipe diameter (out)	mm	20	20	20	20	20	20	20	20	20
Wall-mounted dimensions	Height mm	300	300	300	300	300	300	300	300	300
	Width mm	790	790	790	790	900	1,100	1,100	1,100	1,100
	Depth mm	230	230	230	230	230	260	260	260	260
Wall-mounted weight	kg	9.0	10.0	10.0	10.0	11.0	14.5	15.0	15.0	15.0
Electrical power		1 ~230V 50Hz	1 ~230V 50Hz	1 ~230V 50Hz	1 ~230V 50Hz	1 ~230V 50Hz	1 ~230V 50Hz	1 ~230V 50Hz	1 ~230V 50Hz	1 ~230V 50Hz

Wall-mounted with external expansion valve

		RPK-0.4FSNH4M	RPK-0.6FSNH4M	RPK-0.8FSNH4M	RPK-1.0FSNH4M	RPK-1.5FSNH4M
Adjustable power		-	-	0.60-0.80	1.00-1.30	-
Nominal capacity (VRF SET FREE)	Cooling kW		1.10	1.70	2.20	2.80
	Heating kW		1.30	1.90	2.50	3.20
Nominal capacity (VRF IVX)	Cooling kW		-	-	2.00	2.50
	Heating kW		-	-	2.20	2.80
Air flow (Low - Medium - High - Very high)	m3/h	360-402-438-450	360-420-450-480	390-420-480-600	390-420-480-600	450-540-660-840
Sound pressure (Low - Medium - High - Very high)	dB(A)	29-30-31-32	29-31-32-35	30-32-35-39	30-32-35-39	33-36-40-46
Sound power (High)	dB(A)	49	49	53	53	58
Pipe diameter	Liquid-gas inches	1/4-1/2	1/4-1/2	1/4-1/2	1/4-1/2	1/4-1/2
Condensate pipe diameter (out)	mm	20	20	20	20	20
Wall-mounted dimensions	Height mm	300	300	300	300	300
	Width mm	790	790	790	790	900
	Depth mm	230	230	230	230	230
Wall-mounted weight	kg	9.0	10.0	10.0	10.0	11.0
Electrical power		1 ~230V 50Hz	1 ~230V 50Hz	1 ~230V 50Hz	1 ~230V 50Hz	1 ~230V 50Hz

Compatible controls and accessories:

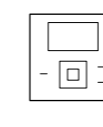

Wired control with programmer
PC-ARFP1E



Wireless remote control
PC-AWR

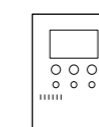

Simplified remote control
PC-ARH

Others

- Optional functions connector (5 units) PCC- 1A
- Receiver kit for PC- AWR control (PC-ALHZ1). Compatible with RPK-FSN(H)3M

VRF Systems

Consoles



Compact design

The RPF(l) units are **only 220 mm deep by 620 mm high** and can be installed along the wall, taking up minimum floorspace. Moreover, it can be installed in confined spaces inside buildings.

Remote control

These units have an optional remote control which can be integrated under the enclosure's plastic cover. (Fig. 1)

Adjustable direction

In RPF(l) units the air output direction can be adjusted in line with requirements. (Fig. 2)

Fig. 1

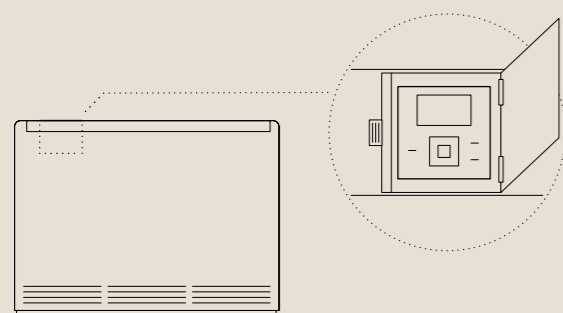
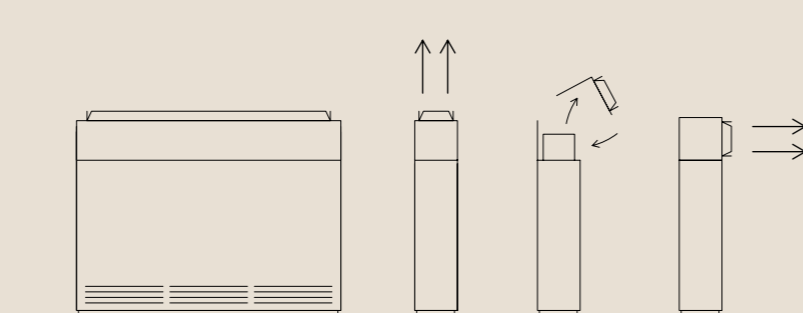
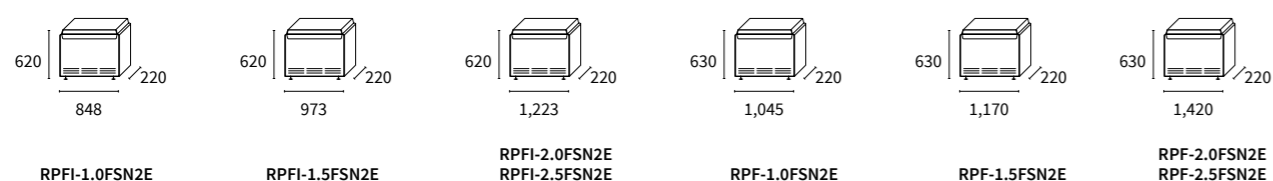

Fig. 2



Indoor units



Console without casing

			RPF1-1.0FSN2E	RPF1-1.5FSN2E	RPF2-2.0FSN2E	RPF2-2.5FSN2E
Adjustable power			-	1.30-1.50	1.80-2.00	2.30-2.50
Nominal capacity (VRF SET FREE)	Cooling	kW	2.80	4.00	5.60	7.10
	Heating	kW	3.20	4.80	6.30	8.50
Nominal capacity (VRF IVX)	Cooling	kW	2.50	3.60	5.00	5.60
	Heating	kW	2.80	4.00	5.60	6.30
Air flow (High - Medium - Low)	m3/h		510-420-360	720-600-540	960-840-660	960-840-660
Sound pressure (High - Medium - Low)	dB(A)		35-32-29	38-35-31	39-36-32	42-38-34
Sound power (High)	dB(A)		57	60	60	60
Pipe diameter	Liquid-gas	inches	1/4-1/2	1/4-1/2	1/4-5/8	3/8-5/8
		mm	18.5	18.5	18.5	18.5
Console dimensions	Height	mm	620	620	620	620
	Width	mm	848	973	1,223	1,223
	Depth	mm	220	220	220	220
Console weight	kg		19.0	23.0	27.0	28.0
Electrical power			1 ~230V 50Hz	1 ~230V 50Hz	1 ~230V 50Hz	1 ~230V 50Hz

Console with casing

			RPF-1.0FSN2E	RPF-1.5FSN2E	RPF-2.0FSN2E	RPF-2.5FSN2E
Adjustable power			-	1.30-1.50	1.80-2.00	2.30-2.50
Nominal capacity (VRF SET FREE)	Cooling	kW	2.80	4.00	5.60	7.10
	Heating	kW	3.20	4.80	6.30	8.50
Nominal capacity (VRF IVX)	Cooling	kW	2.50	3.60	5.00	5.60
	Heating	kW	3.80	4.00	5.60	6.30
Air flow (High - Medium - Low)	m3/h		510-420-360	720-600-540	960-840-660	960-840-660
Sound pressure (High - Medium - Low)	dB(A)		35/32/29	38/35/31	39/36/32	42/38/34
Sound power (High)	dB(A)		57	60	60	60
Pipe diameter	Liquid-gas	inches	1/4-1/2	1/4-1/2	1/4-5/8	3/8-5/8
		mm	18.5	18.5	18.5	18.5
Console dimensions	Height	mm	630	630	630	630
	Width	mm	1,045	1,170	1,420	1,420
	Depth	mm	220	220	220	220
Console weight	kg		25.0	28.0	33.0	34.0
Electrical power			1 ~230V 50Hz	1 ~230V 50Hz	1 ~230V 50Hz	1 ~230V 50Hz

Compatible controls and accessories:



Wired control with programmer
PC-ARFP1E



Wireless remote control
PC-AWR

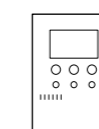

Simplified remote control
PC-ARH

Others

- Optional functions connector (5 units) PCC- 1A
- Receiver kit for PC- AWR control (PC-ALHZ1). Compatible with RPK-FSN(H)3M

Ceiling-mounted

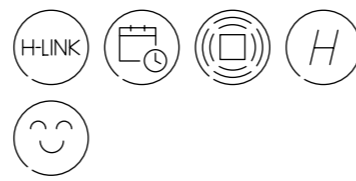

Energy savings

Energy savings of 14% thanks to the presence sensor. The presence sensor in model RPC (1.5-6) FSN3 adjusts operation in accordance with occupancy in the room.

Versatile installation

A second valve has been added to make it easier to install the drainage system, and to increase installation and positioning options.

Convenience

The new drain kit (optional) allows the drain to be installed 600 mm above the top of the indoor unit. (Fig. 1)

High G Speed

Function that can launch the air even further and condition the whole room.

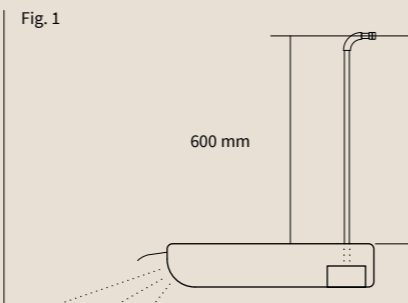

Indoor units

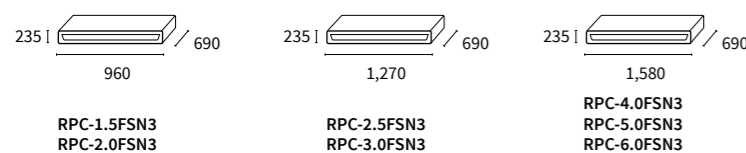

Ceiling-mounted with sensor

			RPC-1.5FSN3	RPC-2.0FSN3	RPC-2.5FSN3	RPC-3.0FSN3	RPC-4.0FSN3	RPC-5.0FSN3	RPC-6.0FSN3
Adjustable power			1.30-1.50	1.80-2.00	2.30-2.50	-	-	-	-
Nominal capacity (VRF SET FREE)	Cooling	kW	4.00	5.60	7.10	8.00	11.20	14.00	16.00
	Heating	kW	4.80	6.30	8.50	9.00	12.50	16.00	18.00
Nominal capacity (VRF IX)	Cooling	kW	3.60	5.00	5.60	7.10	10.00	12.50	14.00
	Heating	kW	4.00	5.60	6.30	8.00	11.20	14.00	16.00
Air flow (Very high - High - Medium - Low)		m ³ /h	900-780-660-540	900-780-660-540	1.140-990-840-690	1.260-1.110-930-750	1.800-1.590-1.320-1.020	2.100-1.860-1.530-1.200	2.220-1.950-1.620-1.260
Sound pressure (Very high - High - Medium - Low)		dB(A)	37/35/31/28	38/35/31/28	38/35/31/28	40/37/33/29	44/42/37/32	48/45/41/35	49/47/42/36
Sound power (High)		dB(A)	53	54	54	56	60	64	65
Pipe diameter	Liquid-gas	inches	1/4-1/2	1/4-5/8	3/8-5/8	3/8-5/8	3/8-5/8	3/8-5/8	3/8-5/8
Condensate pipe diameter (out)		mm	25	25	25	25	25	25	25
Ceiling-mounted dimensions	Height	mm	235	235	235	235	235	235	235
	Width	mm	960	960	1,270	1,270	1,580	1,580	1,580
	Depth	mm	690	690	690	690	690	690	690
Ceiling-mounted weight		kg	26.0	27.0	35.0	35.0	41.0	41.0	41.0
Electrical power			1 ~230V 50Hz	1 ~230V 50Hz	1 ~230V 50Hz	1 ~230V 50Hz	1 ~230V 50Hz	1 ~230V 50Hz	1 ~230V 50Hz

Compatible controls and accessories:



Wired control with programmer
PC-ARFP1E

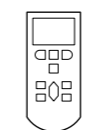

Wireless remote control
PC-AWR
Receiver required

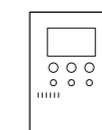

Simplified remote control
PC-ARH

Others

- SOR-NEP presence sensor kit. Compatible with RPC-FSN3
- Optional functions connector (5 units) PCC- 1A

- Receiver kit for PC- AWR control (PC-ALHZ1). Compatible with RPC-FSN3
- Receiver kit for PC- AWR control (PC-ALHP1). Compatible with RPC-FSN3

DX-Kit

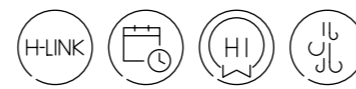

Compatibility

The DX-KIT interface is the device that connects the direct expansion heat exchangers of the ATUs, air curtains and high-flow duct units to Hitachi outdoor units, in order to work in heating and cooling mode.

Regulation

With the option to regulate capacity according to the heat exchangers input and/or output temperature or using an external analogue signal, in accordance with cooling/heating requirements.

Total integration

Its integration means air curtains with direct expansion heat exchangers can also work in cooling, unlike conventional curtains that only operate in heating mode.

Precise temperature

The combination of DX-KIT with RAS-XH(V)NP(E) guarantees the highest levels of precision on the market in terms of maintaining the target temperature (air flow or room temperature).

All elements included

This kit includes: expansion valve, temperature sensors and electronic regulation devices. Compatible with the Commercial range and VRF Set Free Systems.

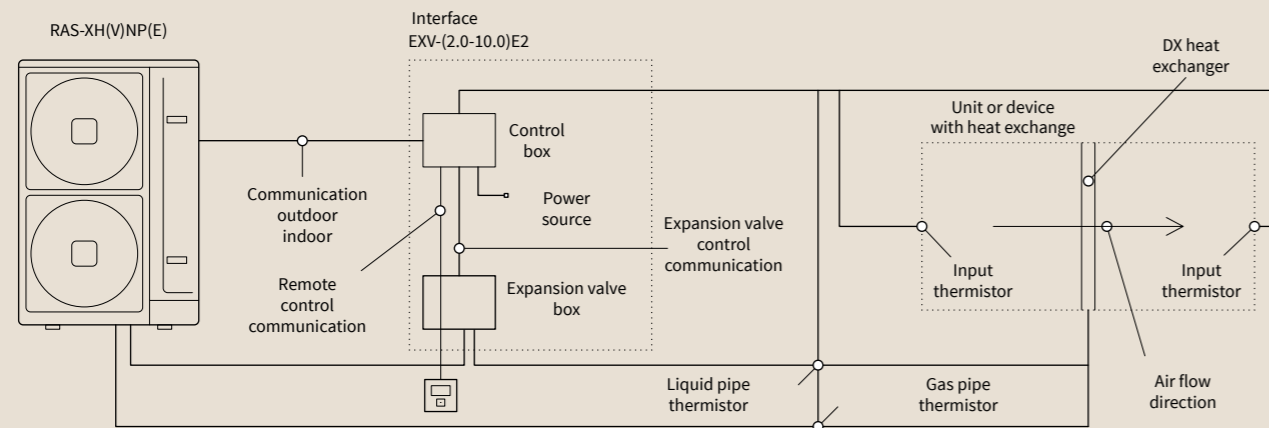

Expansion valve and control box

Outdoor Unit IX Premium DX

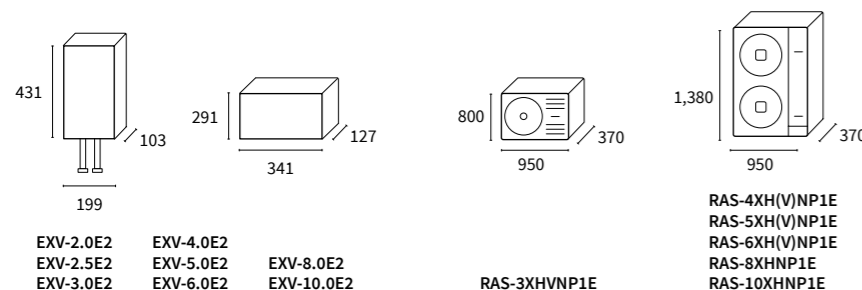

DX-kit - Expansion valve + control box

		EXV-2.0E2	EXV-2.5E2	EXV-3.0E2	EXV-4.0E2	EXV-5.0E2	EXV-6.0E2	EXV-8.0E2	EXV-10.0E2
Capacity	Cooling (Min/Nom/Max) kW	4.00-5.00-5.60	4.80-6.00-6.30	5.70-7.10-8.00	8.00-10.00-11.20	10.00-12.50-14.00	11.20-14.00-16.00	16.00-20.00-22.40	20.00-25.00-28.00
	Heating (Min/Nom/Max) kW	4.50-5.60-7.10	5.60-7.00-7.10	6.40-8.00-9.00	9.00-11.20-12.50	11.20-14.00-16.00	12.80-16.00-18.00	17.90-22.40-25.00	22.40-28.00-31.50
Exchanger volume *	Minimum l	0.57	0.89	1.03	1.51	1.92	1.92	2.92	3.89
	Maximum l	1.64	1.83	2.89	4.56	4.56	5.11	6.93	10.73
Recommended heat exchanger air flow	Minimum m3/h	480	690	750	1,200	1,380	1,500	3,540	4,080
	Maximum m3/h	1,260	1,560	1,800	2,160	2,490	2,550	4,680	5,340
Expansion valve box dimensions	Height mm	431	431	431	431	431	431	431	431
	Width mm	199	199	199	199	199	199	199	199
	Depth mm	103	103	103	103	103	103	103	103
Expansion valve box weight	kg	2.0	2.7	2.7	2.7	2.7	2.7	4.5	4.5
	Control box dimensions	Height mm	291	291	291	291	291	291	291
Control box dimensions	Width mm	341	341	341	341	341	341	341	341
	Depth mm	127	127	127	127	127	127	127	127
	Control box weight	kg	3.0	3.0	3.0	3.0	3.0	3.0	3.0
Electrical power		1 ~ 230 V 50 Hz	1 ~ 230 V 50 Hz	1 ~ 230 V 50 Hz	1 ~ 230 V 50 Hz	1 ~ 230 V 50 Hz	1 ~ 230 V 50 Hz	1 ~ 230 V 50 Hz	1 ~ 230 V 50 Hz

Outdoor Unit IX Premium DX

		RAS-3XHVNP1E	RAS-4X(V)NP1E	RAS-5X(V)NP1E	RAS-6X(V)NP1E	RAS-8X(V)NP1E	RAS-10X(V)NP1E
Capacity	Cooling (Min/Nom/Max) kW	3.20-7.10-8.0	4.50-10.00-11.20	5.70-12.50-14.00	6.00-14.00-16.00	8.00-20.00-22.40	10.00-25.00-28.00
	Heating (Min/Nom/Max) kW	3.50-8.00-10.60	5.00-11.20-14.00	5.00-14.00-18.00	5.00-16.00-20.00	6.30-22.40-28.00	8.00-28.00-35.00
Consumption	Cooling (nom) kW	1.46	1.99	3.11	3.94	5.36	7.88
	Heating (nom) kW	1.52	2.02	2.91	3.61	5.06	7.03
Outside operating temperatures	Cooling °C	15 to 46	15 to 46	15 to 46	15 to 46	15 to 46	15 to 46
	Heating °C	-20 to 15	-20 to 15	-20 to 15	-20 to 15	-20 to 15	-20 to 15
Power	Single-phase	1 ~ 230 V 50 Hz	1 ~ 230 V 50 Hz	1 ~ 230 V 50 Hz	1 ~ 230 V 50 Hz	-	-
	Three-phase	-	3N~ 400V 50Hz	3N~ 400V 50Hz	3N~ 400V 50Hz	3N~ 400V 50Hz	3N~ 400V 50Hz
Air flow	m3/h	2,700	4,800	5,400	6,000	7,620	8,040
Sound pressure level (night mode)	dB(A)	46 (42)	47 (43)	48 (44)	48 (45)	57 (55)	58 (56)
Pipe diameter	Liquid-gas inches	3/8-5/8	3/8-5/8	3/8-5/8	3/8-5/8	3/8-1 1/8	1/2-1 1/8
Maximum pipe length	m	50	75	75	75	100	100
Maximum height difference (highest OU/lowest OU)	m	30/20	30/20	30/20	30/20	30/20	30/20
Compressor		Rotary	Scroll DC Inverter	Scroll DC Inverter	Scroll DC Inverter	Scroll DC Inverter	Scroll DC Inverter
Refrigerant		R410A	R410A	R410A	R410A	R410A	R410A
Refrigerant charge (length without additional charge)	kg (m)	2.3 (30)	4.1 (30)	4.2 (30)	4.2 (30)	5.7 (30)	6.2 (30)
Additional refrigerant charge	g/m	please check	please check	please check	please check	please check	please check
Dimensions (H x W x D)	mm	800x950x370	1,380x950x370	1,380x950x370	1,380x950x370	1,380x950x370	1,380x950x370
Weight	kg	66.0	103.0	103.0	103.0	136.0	138.0

Combinable in accordance with type of application

Type of application	Air curtain	Combinability	VRF IXV VRF IXV		VRF IXV DX		VRF Set Free	
			Single	Outlet air temperature control	Modular	Input air temperature control	Multi	Inlet air temperature control
Air curtain	Controlled variable	Capacity	Single	2 - 10 HP	Modular	2 - 10 HP	Multi	2 - 10 HP
			Single	2 - 10 HP	Modular	2 - 10 HP	Multi	2 - 10 HP
			Single	2 - 10 HP	Modular	2 - 10 HP	Multi	2 - 10 HP
Ducts	Controlled variable	Capacity	Single	2 - 10 HP	Modular	2 - 10 HP	Multi	2 - 10 HP
			Single	2 - 10 HP	Modular	2 - 10 HP	Multi	2 - 10 HP
			Single	2 - 10 HP	Modular	2 - 10 HP	Multi	2 - 10 HP
AHU	Controlled variable	Capacity	Single or modular	Setpoint signal or outlet air temperature control	Single or modular	Setpoint signal or outlet air temperature control	Single or modular	Setpoint signal or outlet air temperature control
			Single or modular	Setpoint signal or outlet air temperature control	Single or modular	Setpoint signal or outlet air temperature control	Single or modular	Setpoint signal or outlet air temperature control
			Single or modular	Setpoint signal or outlet air temperature control	Single or modular	Setpoint signal or outlet air temperature control	Single or modular	Setpoint signal or outlet air temperature control

Compatible controls and accessories:

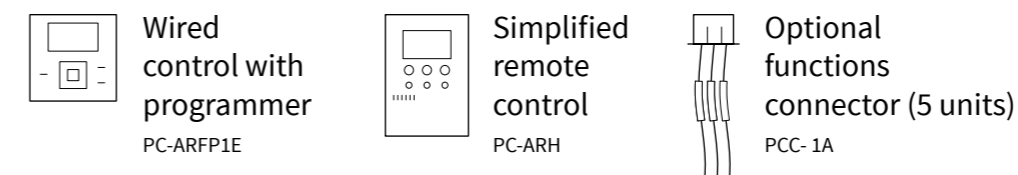

Hydro Free

All applications in one system: heating, cooling, hot water and swimming pool

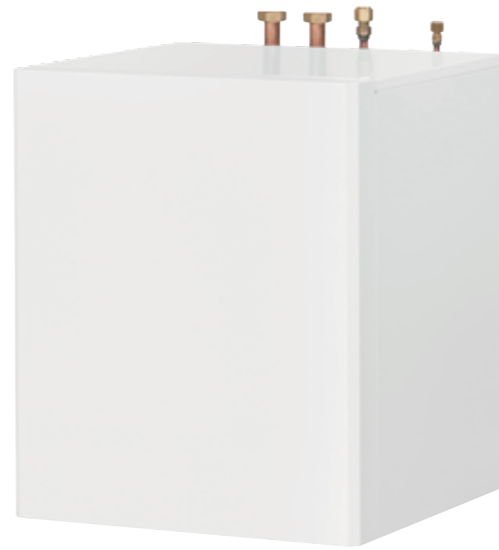
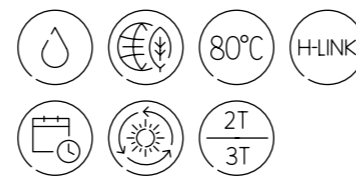

Built-in components

The hydraulic components are all built-in (pump, expansion valve, air purge valve, safety valve, filter, pressure gauge). It is also fitted with a **valve with filter** for protection and to allow cleaning, removing the need to empty the water from the hydraulic circuit in order to clean the filter. Similarly, there is no need for shut-off valves.

Smart cascade cycle

Thanks to the smart cascade cycle, the high temperature Hydro Free can generate hot water up to **80°C** without the need for a heating element. It is fitted with a second R134 compressor which can raise water temperature up to 80°C.

Furthermore, the smart cascade cycle oversees operation of this second compressor so it only works when required due to temperature demand, meaning the Hydro Free can work at two temperatures: 45 or 80°C according to needs, thus maximising energy efficiency.

(Fig. 1)

High flexibility

High and low temperature modules that can be connected to the VRF range (2/3 pipes).

Energy savings

With Hitachi's Hydro Free, **hot water will be freely generated** in applications requiring cooling only installations such as hotels, restaurants and server rooms.

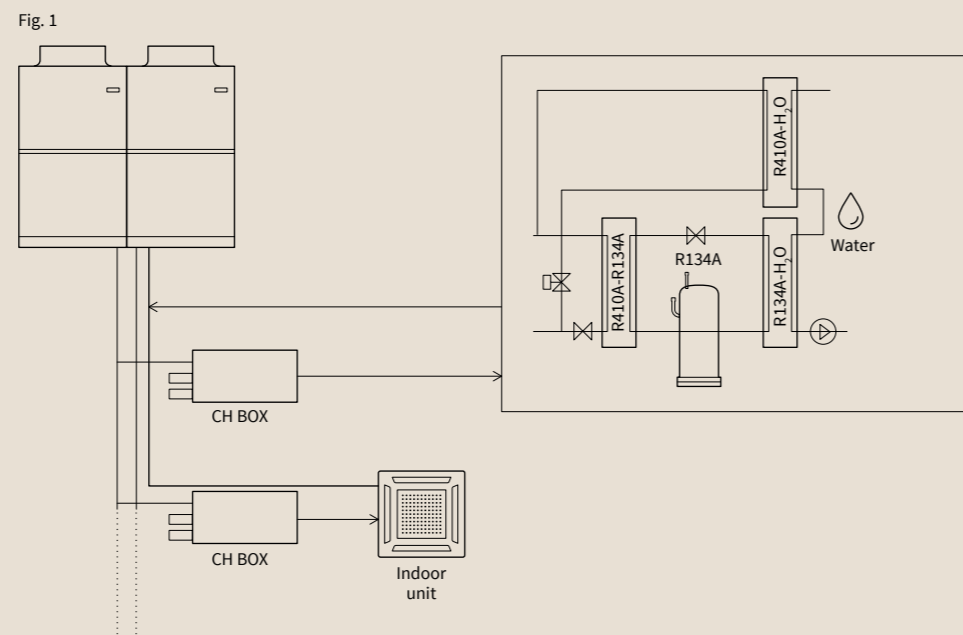

Low Temperature Hydraulic Module

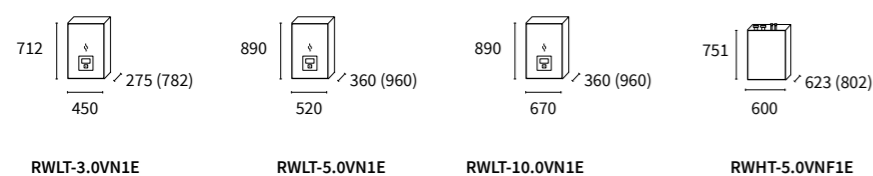

Low Temperature Hydraulic Module

Low Temperature Hydraulic Module

			RWLT-3.0VN1E	RWLT-5.0VN1E	RWLT-10.0VN1E
Capacity	Heating (nominal)	kW	9.00	16.00	31.00
	Cooling (nominal)	kW	7.00	12.60	20.60
Outside operating temperatures	Heating	°C	-20 to 23	-20 to 23	-20 to 23
	Cooling	°C	10 to 52*	10 to 52*	10 to 52*
	DHW	°C	-20 to 52*	-20 to 52*	-20 to 52*
Water production temperature	Heating	°C	20 to 45	20 to 45	20 to 45
	Cooling	°C	7 to 22	7 to 22	7 to 22
	DHW	°C	30 to 40	30 to 40	30 to 40
Nominal water flow (30°C/30°C)		m3/h	1.5	2.7	4.7
Sound power		dB(A)	37	39	47
Refrigerant pipe diameter	Liquid-gas	inches	3/5-5/8	3/5-5/8	3/8-7/8
Water pipe diameter - input		inches	G 1	G 1 -1/4	G 1 -1/4
Water pipe diameter - output		inches	G 1	G 1 -1/4	G 1 -1/4
Expansion vessel volume		l	6	6	10
Minimum water volume of the installation		l	100	150	180
Dimensions (H x W x D (with connections))		mm	712x450x275(782)	890x520x360(960)	890x670x360(960)
Weight		kg	35.0	50.0	62.0
Electrical power			1~ 230 V 50 Hz	1~ 230 V 50 Hz	1~ 230 V 50 Hz

*48°C with RAS-FSXNSE, 52°C with RAS-FSXNPE

High Temperature Hydraulic Module

			RWHT-5.0VNF1E
Capacity	Heating (nominal)	kW	16.00
Outside operating temperatures	Heating	°C	-20 to 23
	DHW	°C	-20 to 52*
Water production temperature	Heating	°C	20 to 80
	DHW	°C	30 to 75
Nominal water flow		m3/h	2.8
Sound power		dB(A)	57
Refrigerant pipe diameter	Liquid-gas	inches	3/8" - 5/8"
Water pipe diameter - input		inches	G 1 - 1/4"
Water pipe diameter - output		inches	G 1 - 1/4"
Expansion vessel volume		l	12
Minimum water volume of the installation		l	80
Compressor			Scroll DC Inverter
Refrigerant			R134A
Refrigerant charge		kg	1.9
Dimensions (H x W x D (with connections))		mm	751x600x623(802)
Weight		kg	129.0
Electrical power			1~230V - 50Hz

*48°C with RAS-FSXNSE, 52°C with RAS-FSXNPE

Compatible controls and accessories:

- Wired control for Hydro Free
- PC-ARFWE

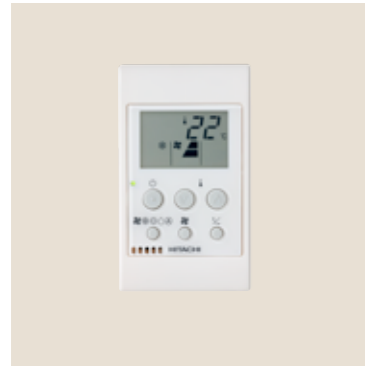

Simplified wired remote control

PC-ARH

- Control of 1 to 16 indoor units (in master and slave).
- Compact size.
- Simplified functions: ON/OFF, mode, temperature, ventilation.
- Preferred function with centralised control or CS-NET Web.

Compatibility: PC-ARH, VRF range - residential range indoor units, System Free indoor units.



Remote control for Hydro Free module

PC-ARFWE

- Multifunction control, with optimised software to set up the Hydraulic Module.
- LCD screen.
- User-friendly.

Compatibility: RWLT-3.0VN1E, RWLT-5.0VN1E, RWLT-10.0VN1E, RWHT-5.0VNF1E.



Wired control with programmer

PC-ARFP1E

- Weekly programming.
- Operating parameters set-up and adjustment.
- Multifunction: Programming for remote ON/OFF options, fault report, automatic routing.
- Control of 1 to 16 indoor units (in master and slave).
- Self-diagnosis, anti-freezing and temperature reduction.
- Built-in environmental sensor.
- Several languages.
- Bespoke air off temperature control per fan coil.
- Power consumption estimation.
- LCD screen.
- User-friendly.

Compatibility: PC-ARFP1E. VRF range System Free indoor units.



Wired control with timer

PC-AWR

- Control of 1 to 16 indoor units (in master and slave).
- LCD screen.
- Two or more units can be controlled simultaneously. The units must be interconnected with control cables.

- Works with an infra-red receiver (not included). Check the model suitable for the indoor unit below.
- Multifunctions: mode, temperature, ventilation, clock, etc.

Compatibility: PC-AWR, VRF Range System Free indoor units.

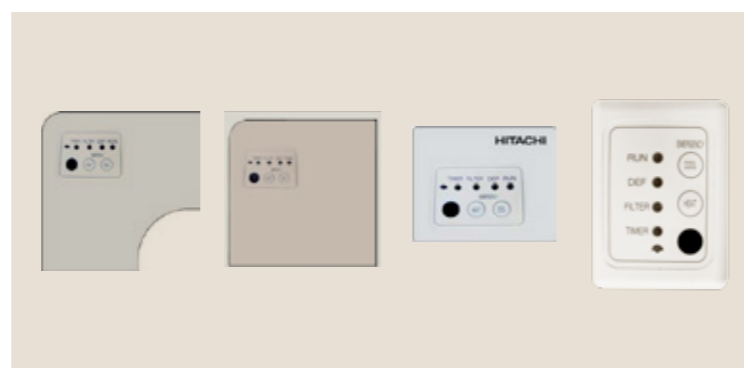

Receivers

Receiver to combine with wireless remote control in the panel:

PC-ALH3

- Compatibility: RCI-FSN4.
- Compatible wireless remote control: PC-AWR.

Receiver to combine with wireless remote control:

PC-ALHC1

- Compatibility: RCIM-FSN4E.
- Compatible wireless remote control: PC-AWR.

Receiver to combine with wireless remote control:

PC-ALHD1

- Compatibility: RCD-FSN3.
- Compatible wireless remote control: PC-AWR.

Receiver to combine with wireless remote control:

PC-ALHP1

- Infra-red receiver for wireless remote control.
- Compatibility: RPC-FSN3.
- Compatible wireless remote control: PC-AWR.

Receiver to combine with wireless remote control on the wall:

PC-ALHZ1

- Infra-red receiver for wireless remote control.
- Compatibility: RPI-FSN3-5, RPIM-FSN4E, RPF(I)-FSN2E, RCI-FSN4, RCIM-FSN4E, RCD-FSN3, RPC-FSN3(E).
- Compatible wireless remote control: PC-AWR.

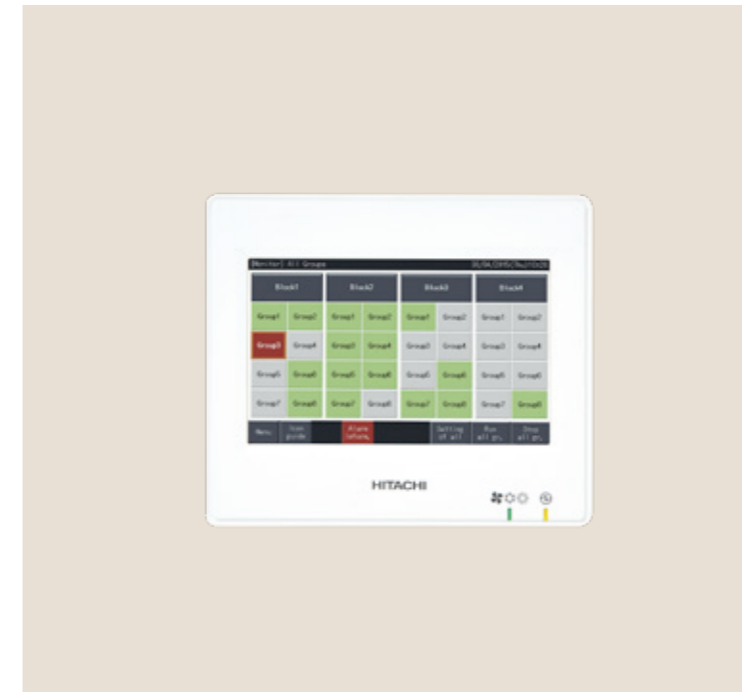

Touchscreen. Centralised system

PSC-A32MN

- Colour touchscreen.
- Monitor operating conditions by blocks/groups.
- Up to 32 groups can be controlled, with up to 16 indoor units per group and a maximum of 160 indoor units per H-link system.
- Up to 8 PSC-A32MN units to a single H-link.

- Main functions: on/off, change operating mode, fan speed control, louvre control, etc.
- Optional functions: restrict operating temperature range, operation schedules, system operation time, etc.

Compatibility: System Free indoor units range, commercial range (VRF IVX), VRF Set Free range.



Touchscreen. Centralised system

PSC-A64GT

- Colour touchscreen.
- Monitor operating conditions by blocks/groups.
- Up to 64 groups can be controlled, with up to 16 indoor units per group and a maximum of 160 indoor units per H-link system. Up to 8 PSC-A64GT units to a single H-link.

- Main functions: on/off, change operating mode, fan speed control, louvre control, etc.
- Optional functions: restrict operating temperature range, operation schedules, system operation time, etc.

Compatibility: System Free indoor units range, commercial range (VRF IVX), VRF Set Free range.



Presence sensor

SOR-MSK (Compatibility RPI-0.4-0.3 FSN5E), PS-MSK2 (Compatibility RCI-FSN4), SOR-NEP (Compatibility RPC-FSN3), SOR-NEC (Compatibility RCIM-FSN4E), SOR-NED (Compatibility RCD-FSN3)

SOR-NED (RCD-FSN3)
SOR-NEC (RCIM-FSN4E)
SOR-NEP (RPC-FSN3)
PS-MSK: Please check PS-MSK2 (RCI-FSN4)
SOR_RCIM_s (RCIM-FSN3E_s).



Centralised control

PSC-A64S

- Control of up to 4 zones with a maximum of 16 groups per zone, i.e. up to 64 groups.
- 16 indoor units per group, with a maximum of 160 indoor units per H-link system. Up to 8 PSC-A64S units to a single H-link.
- In addition to the basic functions, operating mode and temperature setting, the air flow rate and louvre can also be adjusted.
- An alarm code is displayed automatically with detailed information about the error whenever a problem comes about.
- The option of sending and receiving external signals is included, along with the possibility of connecting to the PSC-A1T timer.

Compatibility: System Free indoor units range, commercial range (VRF IVX), VRF Set Free range.



Weekly programming

PSC-A1T

- Programmable weekly timer designed to work with other remote controls that do not have a built-in weekly timer.
- All 7 days of the week can be set, and start/stop can be programmed up to 3 times a day.
- There are two weekly programmes, A and B, which can be easily modified for winter and summer.

Compatibility: System Free indoor units range, commercial range (VRF IVX), VRF Set Free range.

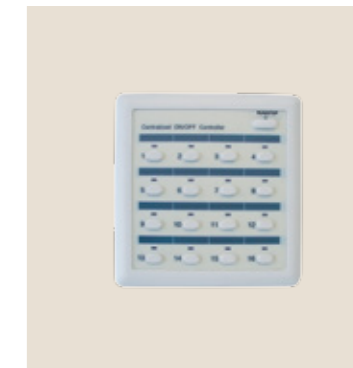

Centralised control ON/OFF

PSC-A16RS

- On/Off controller to manage the status of 16 groups
- Simple operating orders
- Two switches for on/off function
- Individual on/off: to order a group to start up or stop
- Simultaneous on/off: to order all groups to start up or stop Up to 16 groups of units at the same time.
- Up to 8 controllers can be connected to a single H-link.
- Maximum 16 indoor units per group, with a maximum of 160 indoor units per H-link.

Compatibility: System Free indoor units range, commercial range (VRF IVX), VRF Set Free range.



CSNET Manager 2 T10

- Connect up to 16 H-link lines and 1,024 indoor units (16 x 64).
- 10"(15") Capacitive touch screen for the centralised CSNET Manager system.
- Light and compact with high quality screen resolution.
- Improved user interface.
- Web access available through a computer, tablet and Smartphone.
- Modbus included as standard
- Energy management, programmable optional functions.

Compatibility: VRF, IVX System Free indoor units.



CSNET Manager 2 T15

- Connect up to 16 H-link lines and 1,024 indoor units (16 x 64).
- 10"(15") Capacitive touch screen for the centralised CSNET Manager system.
- Light and compact with high quality screen resolution.
- Improved user interface.
- Web access available through a computer, tablet and Smartphone.
- Modbus included as standard
- Energy management, programmable optional functions.

Compatibility: VRF, IVX System Free indoor units.



CSNET Manager 2 SL

- Connect up to 16 H-link lines and 1,024 indoor units (16 x 64).
- Hardware system for the centralised CSNET Manager with an external screen.
- Same features as CSNET Manager when used with external screen.
- No dedicated computer required. One Ethernet port, two USB ports and an HDMI display connection.
- Web access via a computer, tablet and smartphone possible.

Compatibility: VRF, IVX System Free indoor units.



CSNET Lite

- Connect up to 64 indoor units on one H-link line.
- H-link gateway to connect to the centralised CSNET Manager system.
- Simplified solution for small installations.
- Din rail installation.
- No need for a dedicated computer.
- Web access available through computer, tablet and Smartphone.

Compatibility: VRF, IVX System Free indoor units.



Pasarela H-Link

HC-A64NET

- Connect up to 64 indoor units in one H-Link line.
- H-Link gateway to connect up to centralised CSNET Manager system.
- Necessary for CSNET Manager 2 T10 & T15 or SL.

Compatibility: VRF, IVX System Free indoor units.



Stand mounted support

Compatibility: CSNET Manager 2 T10 or T15.

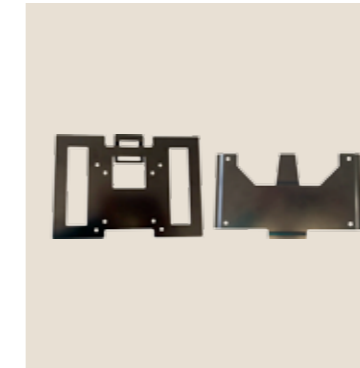

Wall mounted support

Compatibility: CSNET Manager 2 T10.

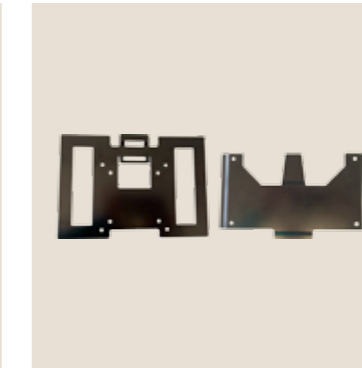

Wall mounted support

Compatibility: CSNET Manager 2 T15.

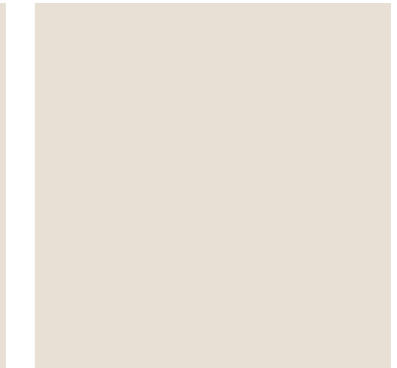

DIN rail Mounting bracket

Compatibility: CSNET Manager 2 SL



Accessories for indoor units

Model	Description
THM-R2AE	Remote temperature sensor
PD-75A	Duct adapter for outside air input in RCI-FSN4 units
PD-75C	Duct adapter for outside air input in RCIM-FSN4E units
PD-150D	Duct adapter for outside air input in RCD-FSN3 units
OACI-160K2	Outdoor air input kit in RCI-FSN4 units
TKCI-160K	T-duct connection kit for the outdoor air input kit
PDF-71C1	Duct connection coupling for indoor air output in RCI-1.0-2.5FSN4 units.
PDF160C1	Duct connection coupling for indoor air output in RCI-3.0-6.0FSN4 units.
SLT-30-200-L600	Noise attenuator KPI-502(X/E)4E units
SLT-30-250-L600	Noise attenuator KPI-802(X/E)4E units
SLT-30-300-L600	Noise attenuator KPI-1002(X/E)4E units
SLT-30-355-L600	Noise attenuator KPI-1502-2002E4E units
HEF-252	F7 high-efficiency filter for KPI-252E4E units
HEF-502	F7 high-efficiency filter for KPI-502(X/E)4E units
HEF-802	F7 high-efficiency filter for KPI-802(X/E)4E units
HEF-1002	F7 high-efficiency filter for KPI-1002(X/E)4E units
HEF-1502	F7 high-efficiency filter for KPI-1502E4E units
HEF-2002	F7 high-efficiency filter for KPI-2002E4E units
D-ICA04	Air input change accessory in RPI-0.4FSN5E units
D-ICA15	Air input change accessory in RPI-0.6-1.5SN5E units

Communication gateways

Model	Description
HC-A64NET	H-link gateway used by CSNET Manager to communicate units via H-link
HC-A8MB	Gateway to connect Hitachi units to a Modbus system. Up to 8 indoor units
HC-A64MB	Gateway to connect Hitachi units to a Modbus system. Up to 64 indoor units
HI-AC-KNX-16/64	Gateway to connect Hitachi units to a KNX system.
HI-AC-KNX-64	KNX gateway using a CSNET WEB system
HI-AC-BAC-16/64	Gateway to connect Hitachi units to a BACNET system
HARC-BX (A/B)	Longworks gateway
PSC-6RAD	Adapter to connect Hitachi home units to H-link centralised systems
PC-A110	Third-party H-link bus integrator in Hitachi centralised systems

Communication components

Model	Description
PSC-5HR	H-Link repeater for H-link installations with over 1000 m.l. of bus layout
PC-AMTB	Connection plate for multi-tenant buildings
PCC1A	3-pin connector cable used as an optional functions connector
PRC-(10/15/20/30)E1	Extension cable for individual or centralised remote controllers: 10, 15, 20 and 30 metres

Pipe kits

E-102SN4
E-162SN4
E-242SN3
E-302SN3
E-102XN3
E-162XN3
E-202XN3
E-242XN3
E-322XN3
E-52XN3

Headers

MH- 84AN1
MH- 108AN
MH- 108XN

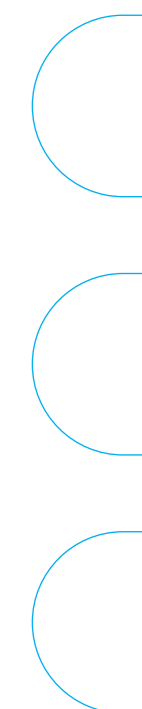

CSNET Manager2

Centralised control system



Central control systems that allows the remote operation and supervision of multiple installations, leading to potential reduced operating costs and more effective maintenance.

Different installation possibilities

1. With a touchscreen

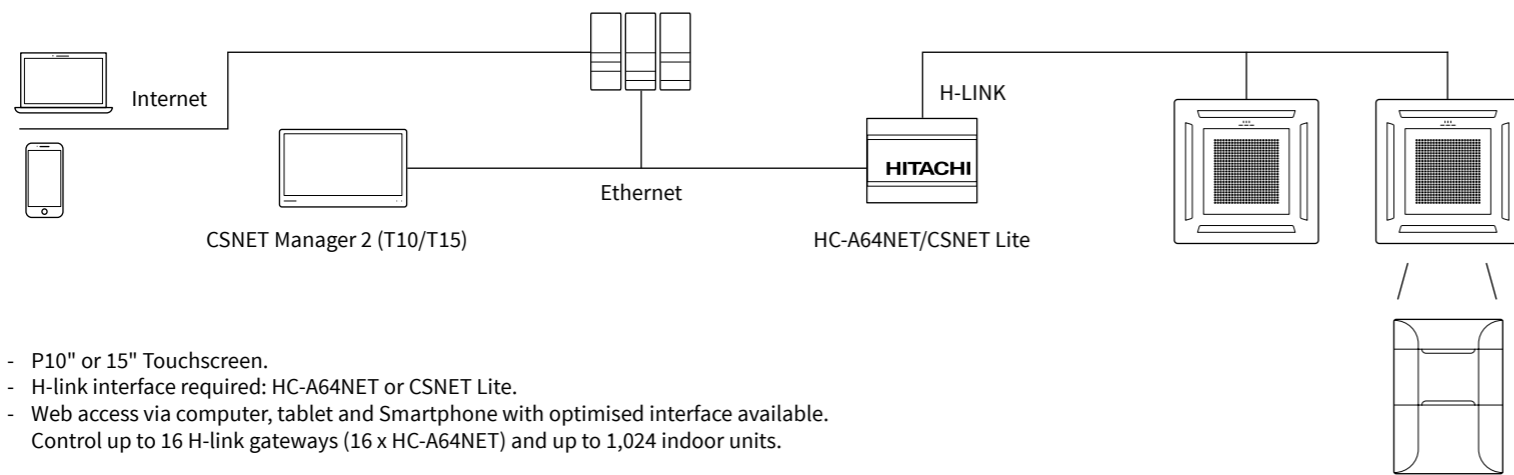

- P10" or 15" Touchscreen.
- H-link interface required: HC-A64NET or CSNET Lite.
- Web access via computer, tablet and Smartphone with optimised interface available. Control up to 16 H-link gateways (16 x HC-A64NET) and up to 1,024 indoor units.

2. Screenless

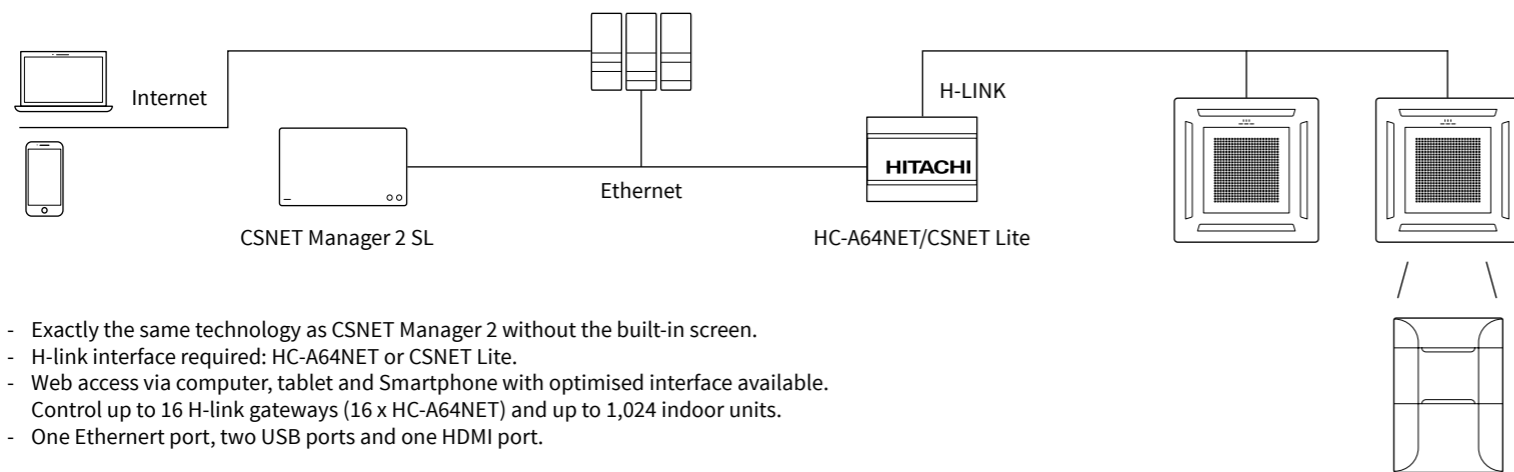

- Exactly the same technology as CSNET Manager 2 without the built-in screen.
- H-link interface required: HC-A64NET or CSNET Lite.
- Web access via computer, tablet and Smartphone with optimised interface available. Control up to 16 H-link gateways (16 x HC-A64NET) and up to 1,024 indoor units.
- One Ethernet port, two USB ports and one HDMI port.

RCS WEB (Virtual remote control available)

- Control the system from your desk for maximum convenience.
- User-friendly interface.
- One or more indoor units controllable from same virtual remote.
- User accounts can be set up with specific rights for specific indoor units.



New Touchscreen with clear, customisable display

Choose from either a 10" or 15" inch screen and enjoy the following benefits:

- New menu view.
- Direct access to optional functions such as remote on/off and alarm signal.
- Power consumption analysis as standard including 3rd party devices.
- Intuitive configuration wizard.

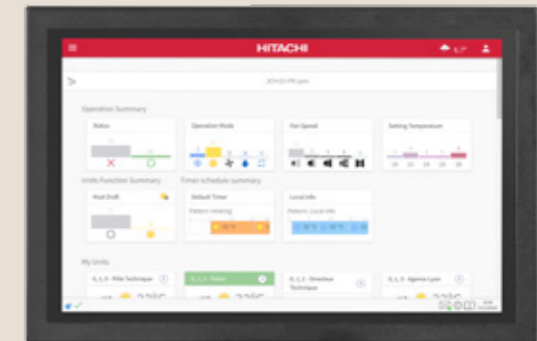

Remote access with smartphone

The system can be accessed at any time via a smartphone.

- Improved usability.
- Identical functions to Touchscreen.
- Graphical representation of units status.



Improves user comfort all year round

Gentle Cool function

In cooling mode a minimum air off temperature can be set per fancoil that will automatically reset to ventilation mode if the air gets too cool for the comfort of the user.

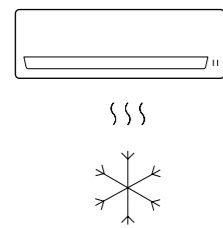

Heat draft function

In heating mode, the indoor unit will remain fan off until air off temperature has reached a pre-set level to avoid cold drafts for occupants.

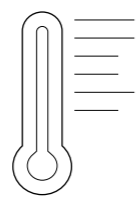

Auto Cool/Heat function

Depending on the conditions in the rooms, CSNET decides when to adjust the system in cold mode or in heat mode, based on detailed control settings.

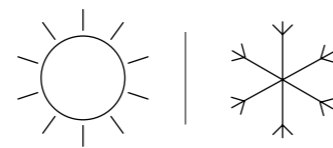

Control and monitoring for management of buildings

Consumption estimates

Energy consumption estimate for an indoor unit or group of indoor units, with the associated cost.* This is achieved either with an optional built-in energy meter, or by entering the energy consumption data by hand.

The data can be displayed in graphs for a more detailed view of the power data and easier analysis of consumption.

*Approximate costs.

Annual programming

The operation mode and set point temperatures for the individual indoor units can be set for an entire year, ensuring maximum comfort and efficiency.

Compatible with Oracle Opera PMS (Fidelio)

CSNET can be linked to FIDELIO (hotel management system) in order to use the check in/check out signal to send commands to the indoor units.

Outdoor unit control options

CSNET can enable functions to reduce the noise level or limit energy consumption for the outdoor units, in accordance with a set schedule or by way of a manual command.

Interlock control

CSNET can be programmed with complex algorithms to bring on units in duty rotation, lead lag and auto changeover on failure for critical systems safety.



You are in control everywhere

Your remote access options

- 1 Remote access with external screen:
 - Access from your computer or smartphone (CSNET network or Internet connection necessary).
 - Simultaneous control of up to 16 devices.
 - Possibility to connect 3rd party screen.
- 2 Remote access with integrated screen:
 - Control via Touchscreen
 - Access from your computer or smartphone (CSNET network or Internet connection necessary).
 - Simultaneous control of up to 16 devices.
- 3 Remote access with multiple devices:
 - Simultaneous access from multiple devices.
 - Compatible with previous generations of CSNET Manager and web systems.

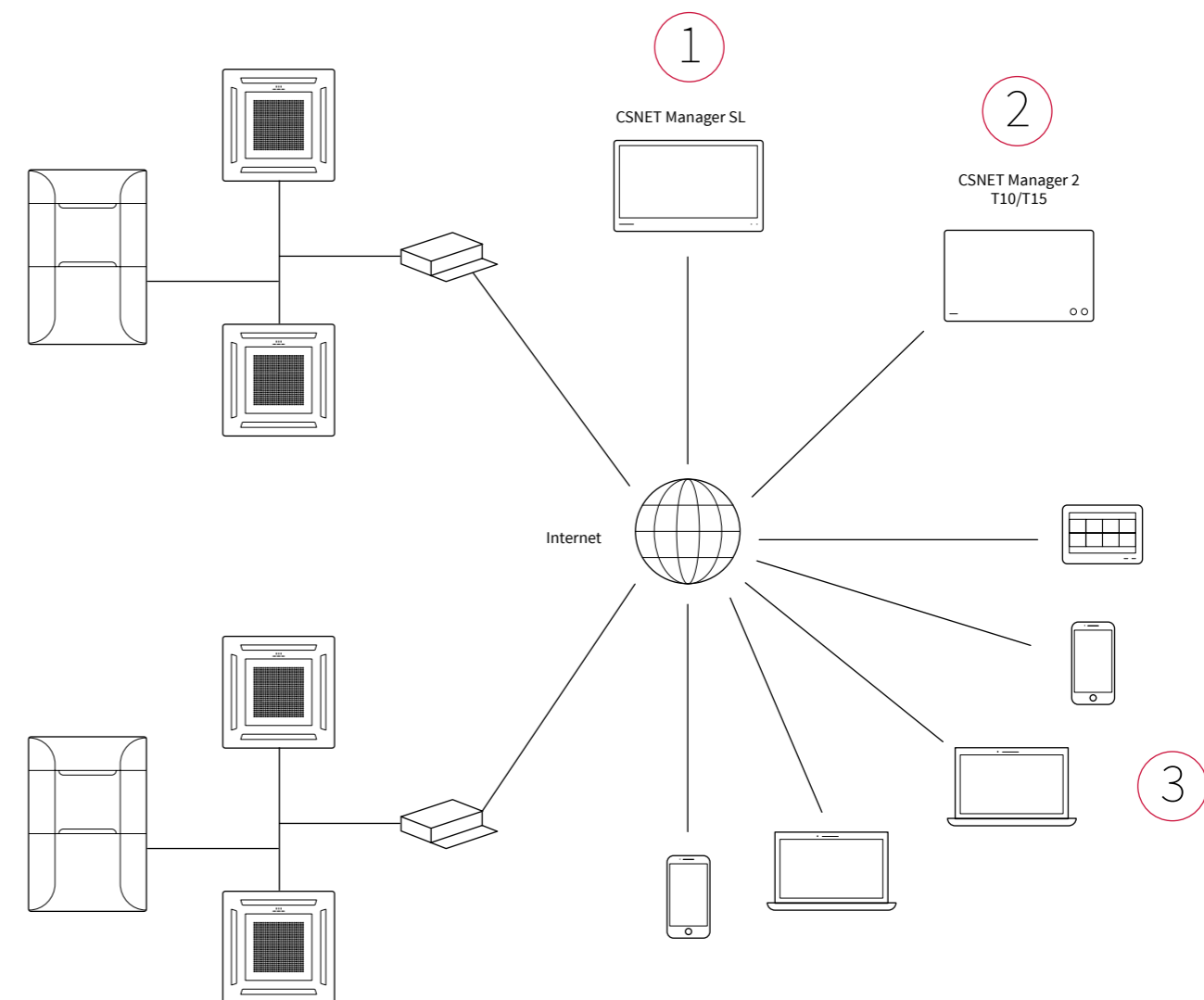

Email notifications

Receive a daily report and emergency alerts in case of alarms.



Data logging history

Allows an in-depth analysis of the system performance in order to improve efficiency and use preventative maintenance effectively.

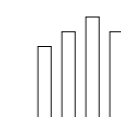

Automatic updates of the software

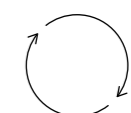

Most building supervision systems use a Modbus connection. The Modbus protocol is a serial dialogue protocol based on a hierarchical structure between a master unit and slave units. It is also a standard in industrial applications.

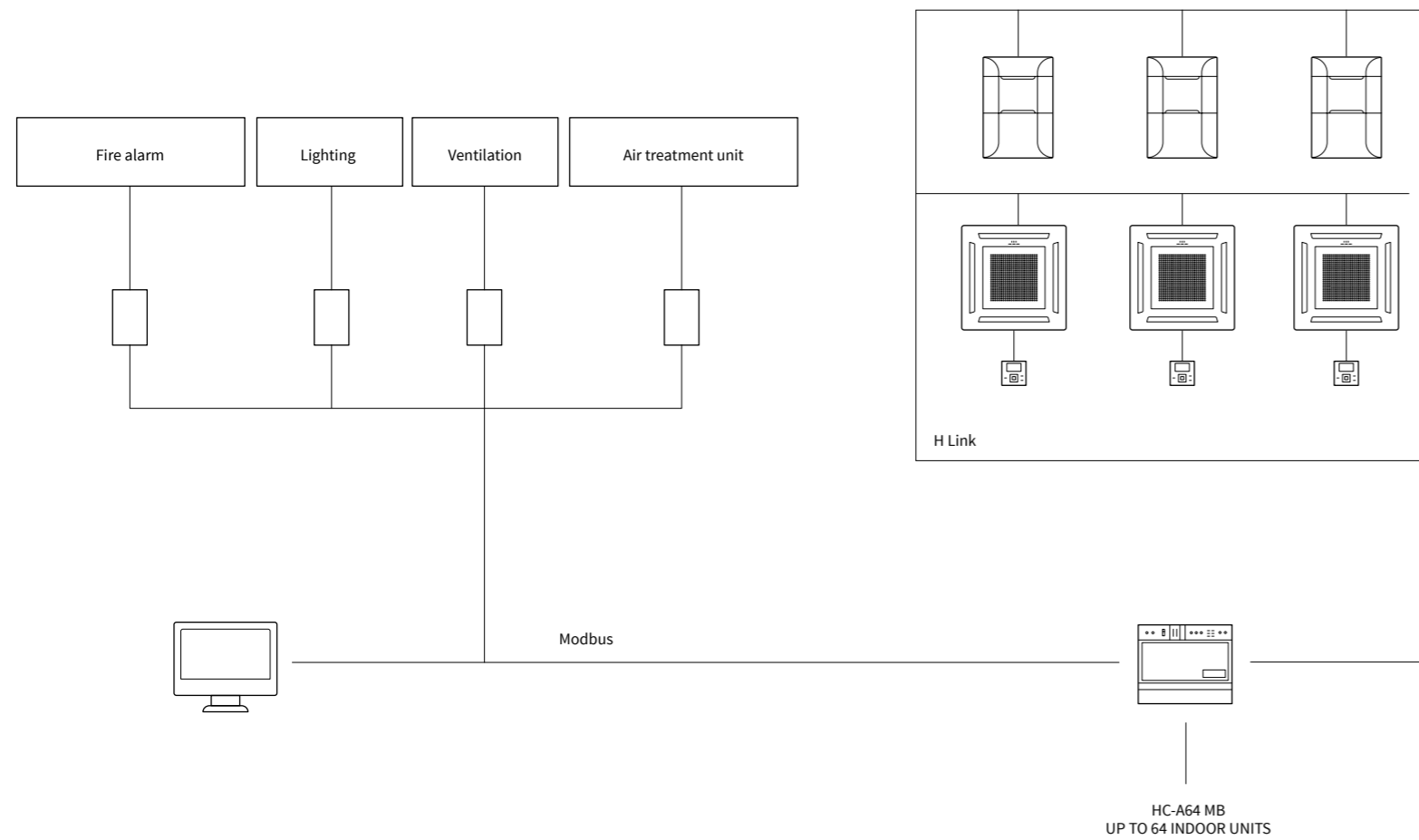
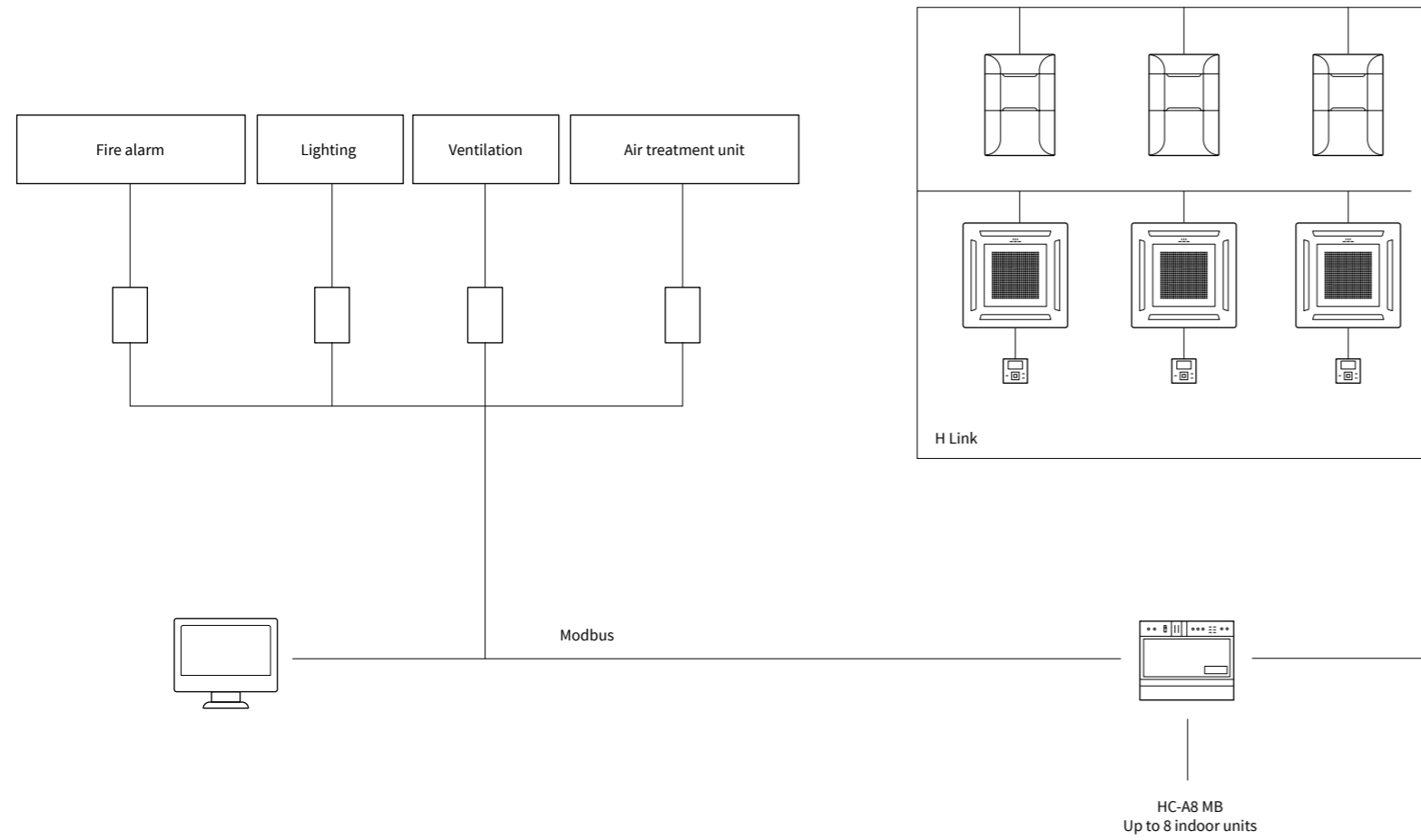

The KNX is a bus which is dedicated to the "Building", and is standardised and independent of the manufacturers (lighting, heating, security, energy management, metering, etc.). Based on standard EIB, EHS, Batibus buses, the KNX guarantees the interoperability of all products bearing the KNX logo. It is an ISO standard. Orientation: Large- and medium-sized buildings, home automation.

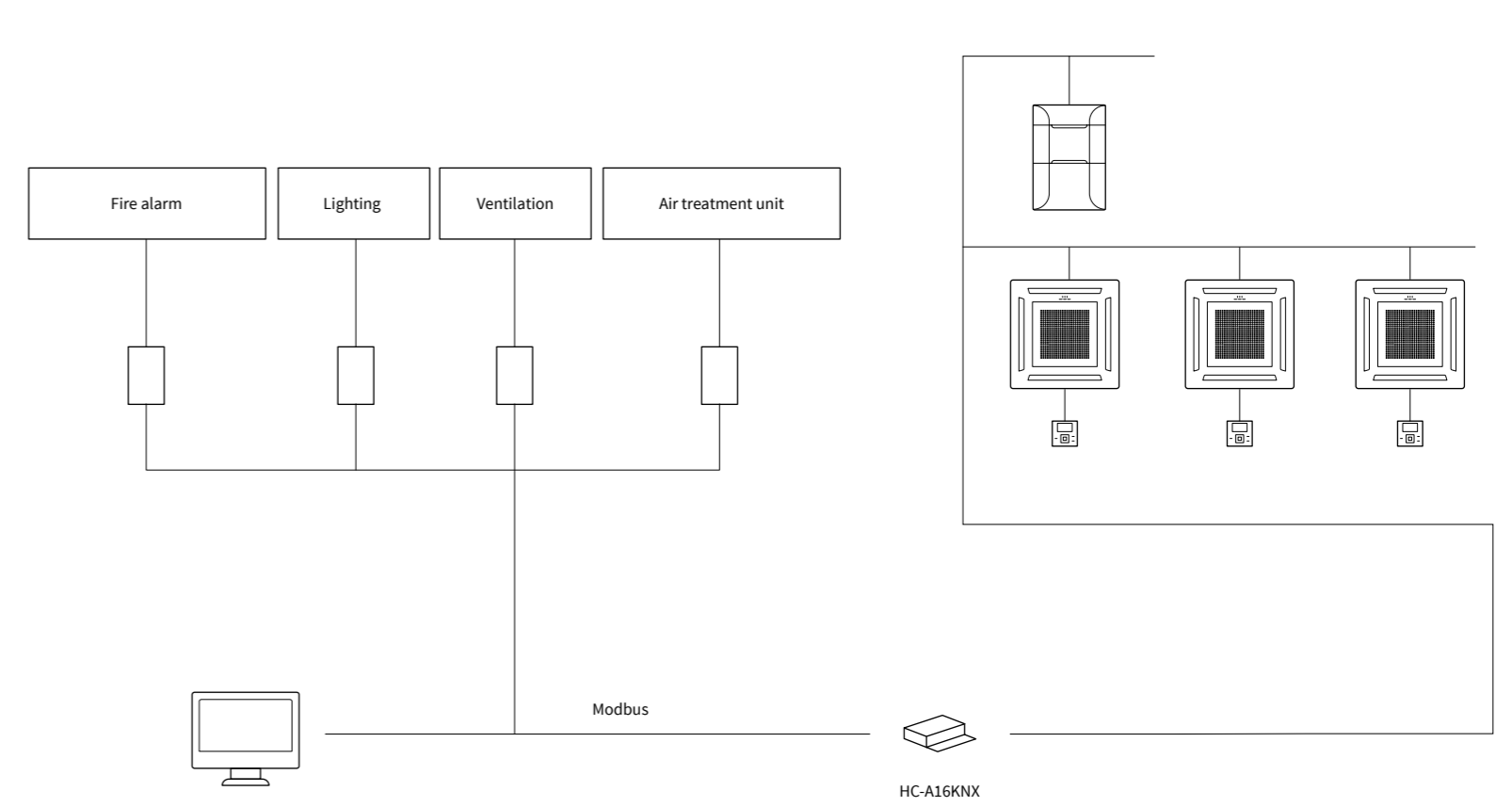
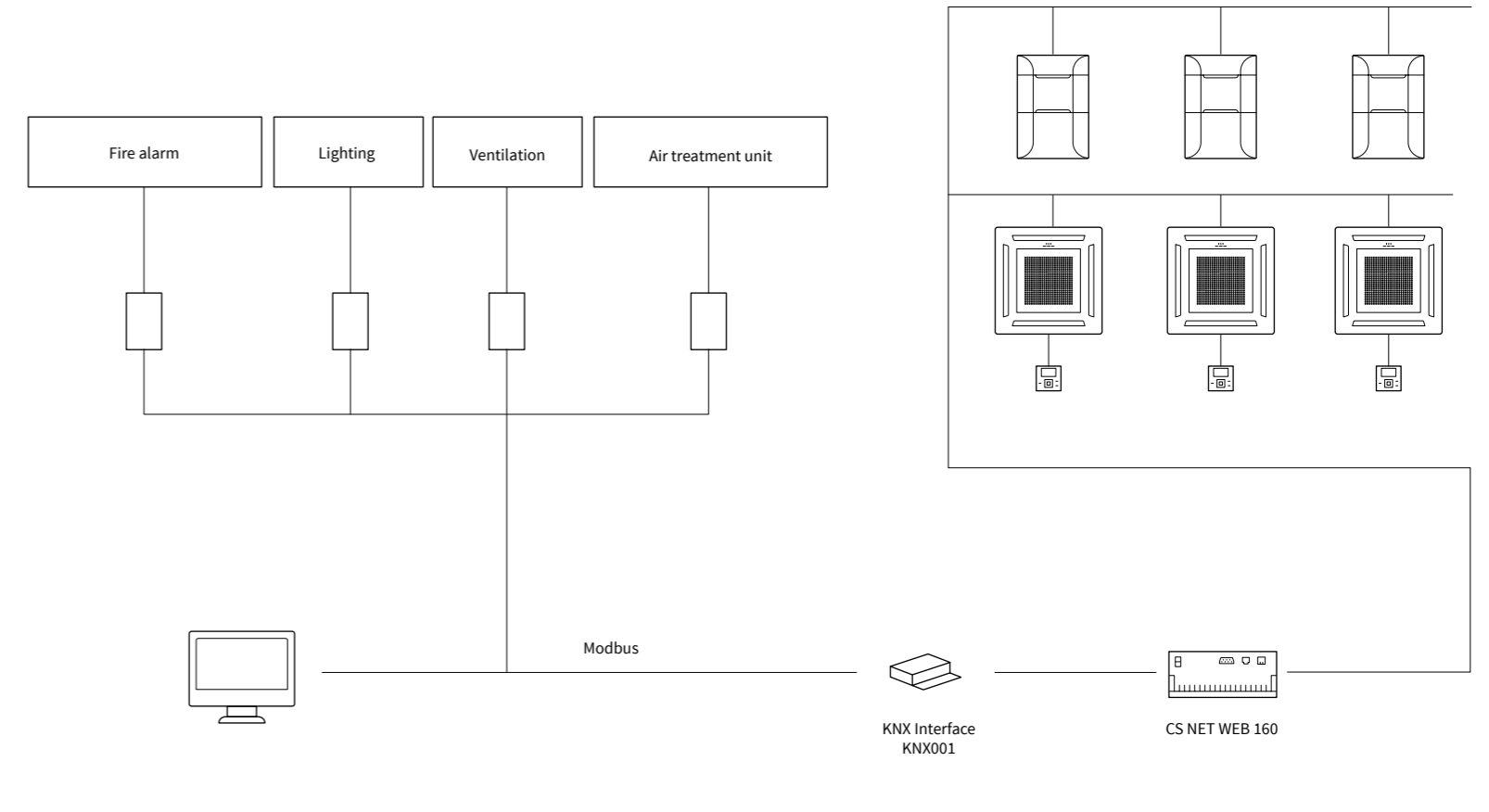

Connects our Modbus interface to a BACNETsystem. For further details, please ask.

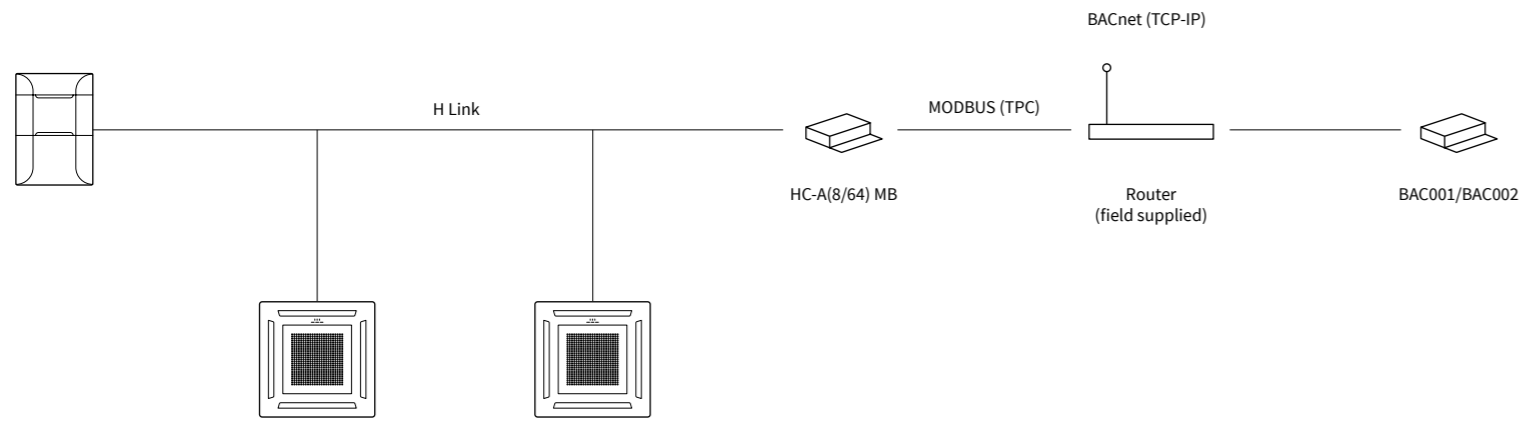

Multitenant

Suitable for multi-property buildings in which there are indoor units which do not have power because the properties are not occupied, e.g. an office building where the units are considered independent at user level but which share the same outdoor conditioning unit. This accessory prevents the outdoor unit from detecting a power failure in the indoor units.

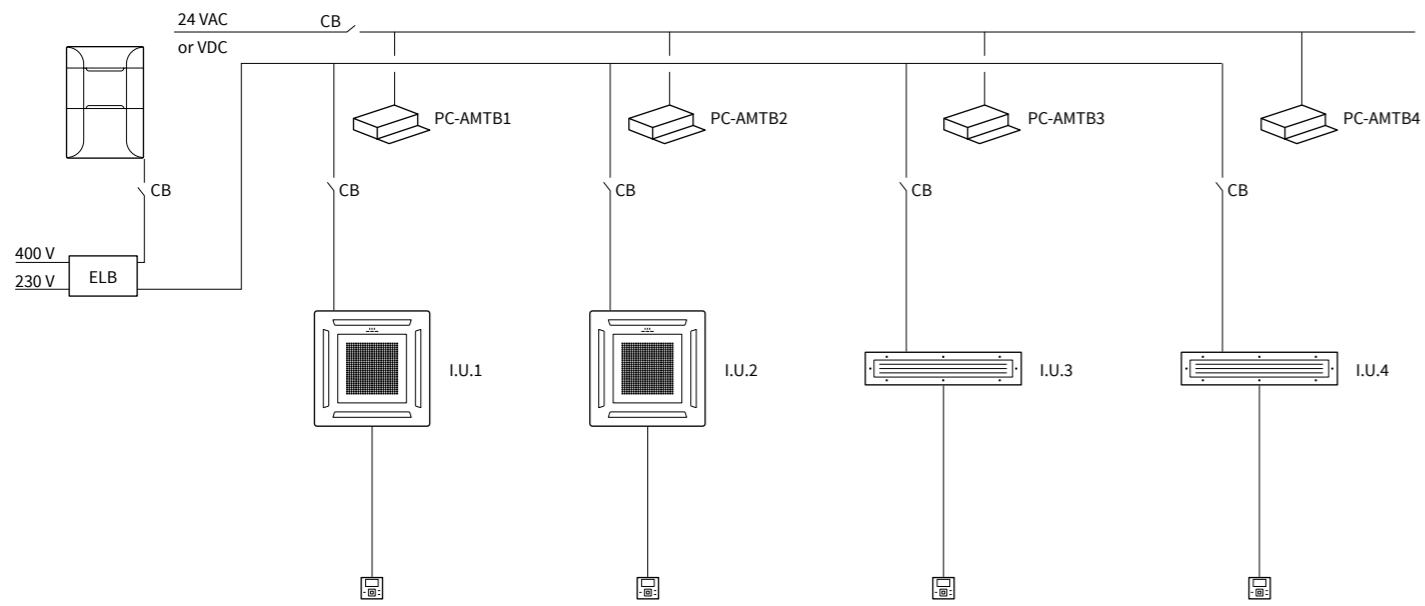

Most building supervision systems. This interface can be used to integrate both air treatment units and non-Hitachi ventilation units in Hitachi's centralised management system.

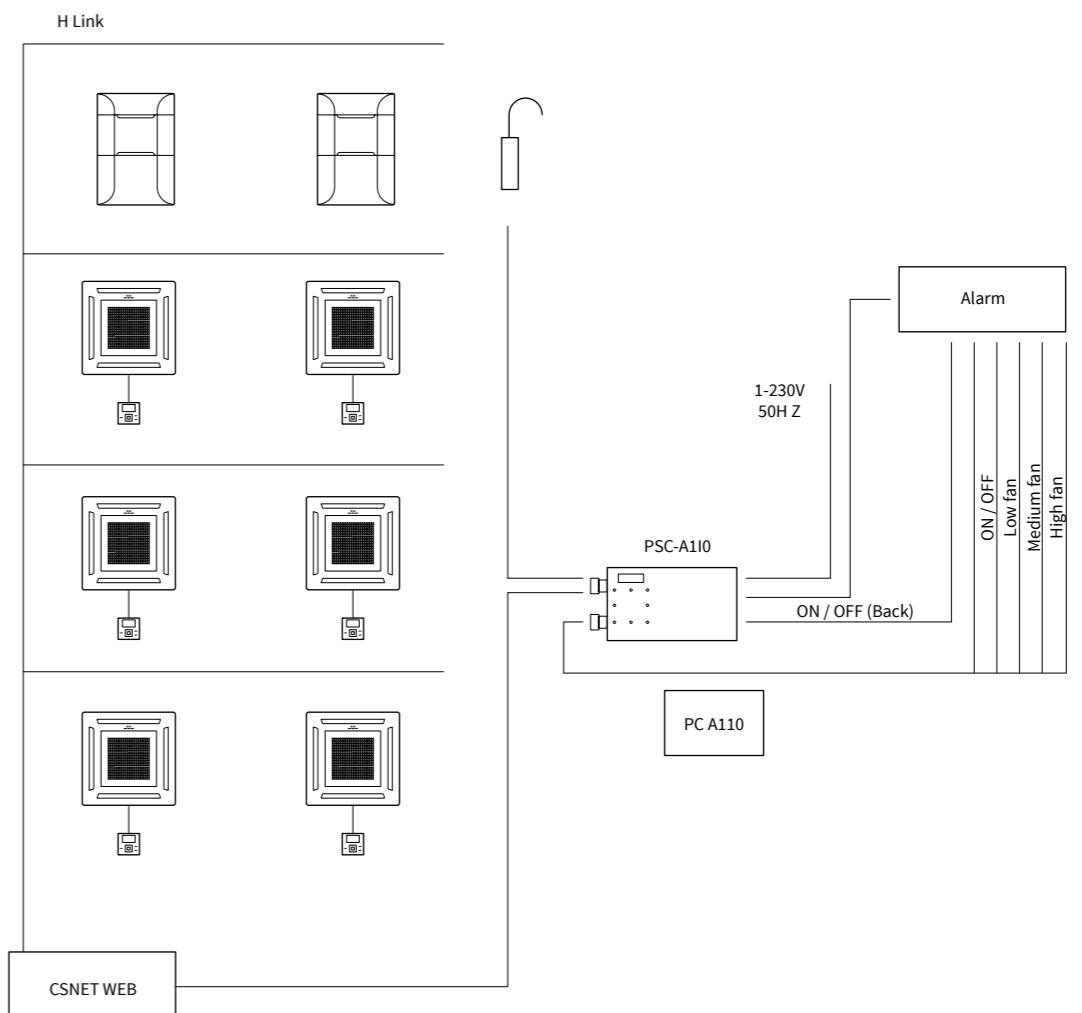
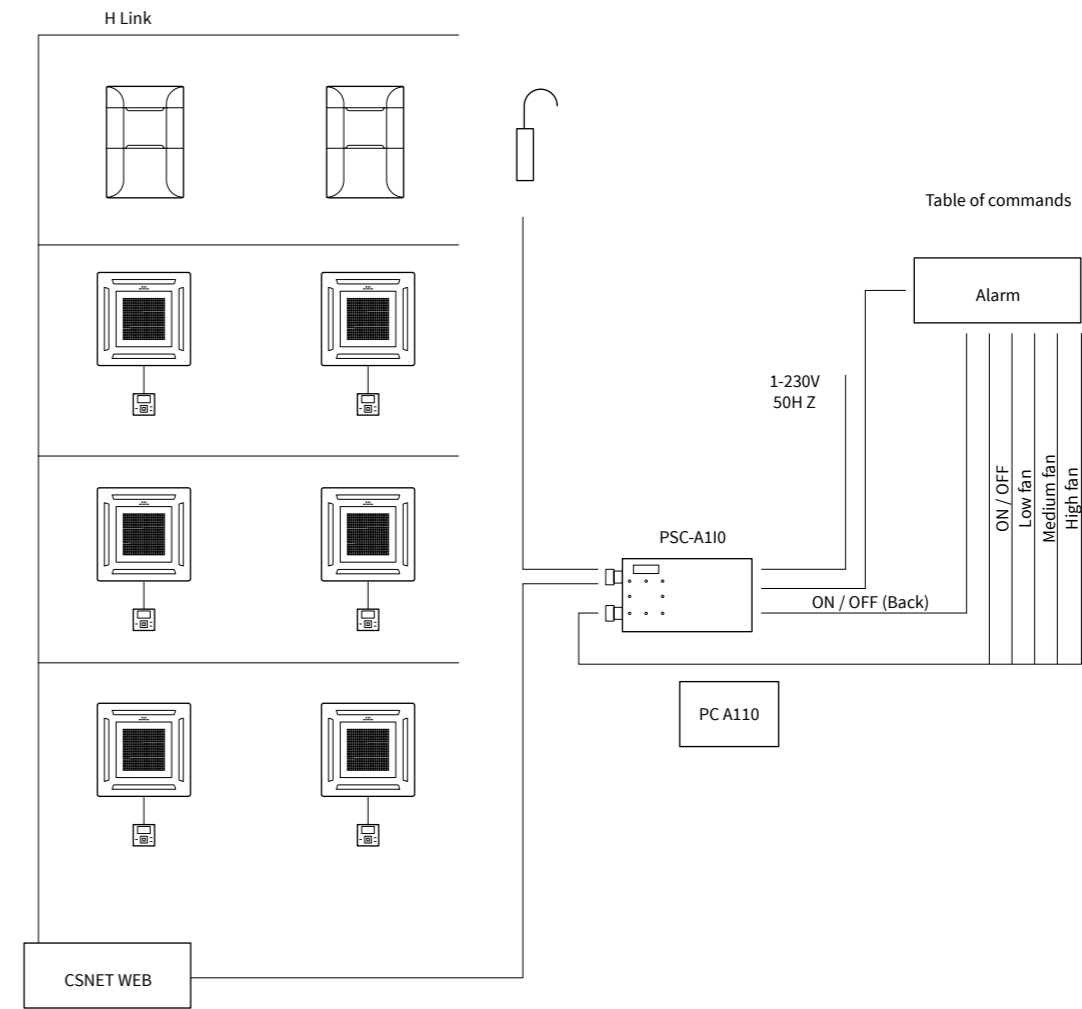

Renewing the indoor air in premises is key to achieving a good environment, both in terms of air quality and comfort. The Hitachi air renewal range not only ensures high indoor air quality, but also saves energy when using the climate-control system



— Air renewal



Air renewal

Quick selection table

Air renewal

		Air flow (m3/h)						expansion coil
		250	500	800	1000	1500	2000	
Heat recovery unit (KPI)	KPI-252-2002(E)4E	•	•	•	•	•	•	
								
	KPI-502-1002X4E		•	•	•			•
								
Econofresh (free cooling)	EF-456N1E	RPI-4FSN5E			RPI-5FSN5E		RPI-6FSN5E	
			•	•	•			



Air renewal



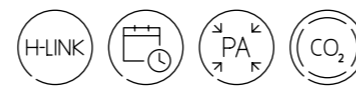

Heat recovery units

KPI High-efficiency air recovery

KPI-252~2002(E)4E



Option to control an external back-up heating element

The heating element starts operating when the temperature drops below -5 °C. Operation is recommended when high air discharge temperatures are required.

Noise reduction

Noise attenuator available, achieving a reduction of up to 5 dB(A) (see accessories).

Automatic by-pass

The KPI units have an automatically controlled internal by-pass damper which removes the need to add thermal load with the ventilation air supply when outdoor conditions are unfavourable for heat recovery.

Versatile ventilation systems

The user can choose from three operating options to ensure maximum comfort and also improve indoor air quality through renewal: forced energy recovery, free ventilation and automatic ventilation (default).

G3 and F7 filters to purify the air

KPIs are supplied from the factory with two G3 filters, one for the air input and one for the output. In addition, a high-efficiency F7 air filter (classified according to EN779) is available as an accessory for installations where an additional filter section is required to ensure indoor air quality, reducing the effects of outdoor pollution.

Static pressure adjustment

KPIs are designed for installation in almost any facility.

The ventilation pressure level can be adjusted quickly and easily using the base plate, in accordance with installation requirements. This guarantees that ventilation flow is reached.

KPIs also have an extra-high speed for installations with long duct runs or for additional filters.

Compliance with standard

Compliance with the ErP Ecodesign Directive Lot 6 for ventilation units with requirements in force as of 1st January 2018.

CO₂ sensor for automatic ventilation

Two options available:
 - Automatic speed mode
 For CO₂ sensors with proportional output. Fan speed is adjusted automatically via the output sensor, always ensuring high indoor air quality without any user intervention.

- High CO₂ concentration mode
 The KPI unit will operate at its set ventilation speed unless the CO₂ concentration exceeds the sensor's detection threshold, in which case it will operate at maximum speed, helping to reduce CO₂ levels. It will return to set speed once the sensor signal goes off.

Heat recovery unit

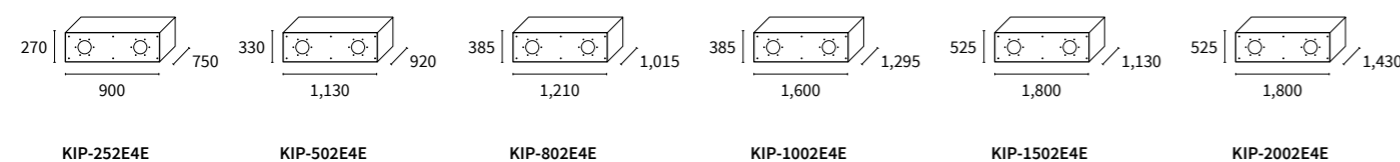

Heat recovery unit

		KPI-252E4E	KPI-502E4E	KPI-802E4E	KPI-1002E4E	KPI-1502E4E	KPI-2002E4E
Air flow (Low - Medium - High)	m ³ /h	180-208-250	360-420-500	540-650-800	620-800-1.000	950-1.250-1.500	1.200-1.450-2.000
Static pressure (Low - Medium - High)	Pa	30-35-55	37-50-80	40-60-90	40-65-95	45-70-100	40-65-120
Maximum static pressure at nominal air flow	Pa	240	210	120	190	180	170
Outside operating temp.	°C	-20 to 46 *	-20 to 46 *	-20 to 46 *	-20 to 46 *	-20 to 46 *	-20 to 46 *
Exchanger type		Air-to-air cross flow	Air-to-air cross flow	Air-to-air cross flow	Air-to-air cross flow	Air-to-air cross flow	Air-to-air cross flow
Heat exchanger efficiency (High - Medium - Low)	%	79-77-74	77-75-73	79-78-76	81-78-76	80-76-73	80-78-76
Enthalpic exchanger efficiency in heating (High)	%	66.0	65.0	65.0	68.0	68.0	66.5
Enthalpic exchanger efficiency in cooling (High)	%	60.0	61.0	62.0	62.0	62.5	61.5
Sound pressure (Low - Medium - High)	dB(A)	25-27-28	30-31-33	33-34-35	32-34-37	35-37-39	36-39-40
Sound power	dB(A)	43	51	54	55	56	57
Dimensions (H x W x D)	mm	270x900x750	330x1,130x920	385x1,210x1,015	385x1,600x1,295	525x1,800x1,130	525x1,800x1,430
Diameter dimensions air intake mouth	mm	Ø 160	Ø 200	Ø 250	Ø 300	Ø 355	Ø 355
Weight	kg	34.0	46.0	51.0	79.0	97.0	106.0
Filter type included		G3	G3	G3	G3	G3	G3
Electrical power		1~ 230 V 50 Hz	1~ 230 V 50 Hz	1~ 230 V 50 Hz	1~ 230 V 50 Hz	1~ 230 V 50 Hz	1~ 230 V 50 Hz

*An electric heater and an additional air input thermistor (THM4 - to be installed before the electric heater) must be installed when the temperature drops below -5°C (DB)

Air renewal

Compatible controls and accessories:

Wired control with programmer
PC-ARFP1E

Noise attenuator
 SLT-30-200-L600
 Compatible with KPI-502E4E
 SLT-30-250-L600
 Compatible with KPI-802E4E
 SLT-30-300-L600
 Compatible with KPI-1002E4E
 SLT-30-355-L600
 compatible with KPI-1502-2002E4E

High-efficiency filter
 HEF-252
 Compatible with KPI-252E4E
 HEF-502
 Compatible with KPI-502E4E
 HEF-802
 Compatible with KPI-802E4E
 HEF-1002
 Compatible with KPI-1002E4E
 HEF-1502
 Compatible with KPI-1502E4E
 HEF-2002
 Compatible with KPI-2002E4E

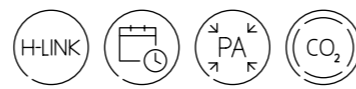

Heat recovery units

Active KPI. High-efficiency recovery with direct expansion coil



Active KPI-X4E

With direct expansion coil, which conditions the outdoor air in accordance with indoor requirements.

Compliance with standard

Compliance with the ErP Ecodesign Directive Lot 6 for ventilation units with requirements in force as of 1st January 2018.

G3 and F7 filters to purify the air

KPIs are supplied from the factory with two G3 filters, one for the air input and one for the output. In addition, a high-efficiency F7 air filter (classified according to EN779) is available as an accessory for installations where an additional filter section is required to ensure indoor air quality, reducing the effects of outdoor pollution.

Versatile ventilation systems

The user can choose from three operating options to ensure maximum comfort and also improve indoor air quality through renewal: forced energy recovery, free ventilation and automatic ventilation (default).

Static pressure adjustment

KPIs are designed for installation in almost any facility.

The ventilation pressure level can be adjusted quickly and easily using the base plate, in accordance with installation requirements. This guarantees that ventilation flow is reached.

KPIs also have an extra-high speed for installations with long duct runs or for additional filters.

Flexibility

Active KPI is compatible with:
- 2 and 2.5 HP Utopia.
- VRF Mini and VRF Set Free Sigma

Air adaptation

Additional treatment beforehand adapts the air to the conditions required in the room.

Air flow temperature control

The Active KPI acts just like another indoor unit. The control will take the temperature set using the remote control as the required discharge temperature.

Automatic by-pass

The KPI units have an automatically controlled internal by-pass damper which removes the need to add thermal load with the ventilation air supply when outdoor conditions are unfavourable for heat recovery.

Heat recovery unit

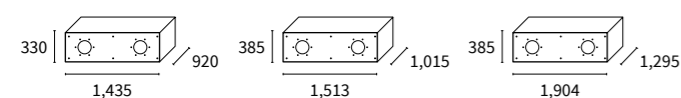

KPI-502X4E

KPI-802X4E

KPI-1002X4E

Heat recovery unit with direct expansion coil

		KPI-502X4E	KPI-802X4E	KPI-1002X4E
Nominal capacity (recovered)	Cooling	kW	5.32 (1.81)	10.83 (3.73)
	Heating	kW	6.92 (2.12)	12.93 (4.43)
Air flow (Low - Medium - High)		m ³ /h	380-430-500	590-700-800
Static pressure (Low - Medium - High)		Pa	60-82-90	57-80-110
Maximum static pressure at nominal air flow		Pa	165	110
Outside operating temp.		°C	-20 to 40	-20 to 40
Exchanger type			Air-to-air cross flow	Air-to-air cross flow
Heat exchanger efficiency (High - Medium - Low)		%	76-75-73	79-78-76
Enthalpic exchanger efficiency in heating (High)		%	65	65
Enthalpic exchanger efficiency in cooling (High)		%	61	62
Sound pressure (Low - Medium - High)		dB(A)	29-30-32	32-33-34
Sound power		dB(A)	50	53
Pipe diameter	Liquid-gas	inches	1/4-1/2	1/4-5/8
Dimensions (H x W x D)		mm	330x1,435x920	385x1,513x1,015
Diameter dimensions air intake mouth		mm	Ø 200	Ø 250
Weight		kg	62	69
Filter type included			G3	G3
Electrical power			1~ 230 V 50 Hz	1~ 230 V 50 Hz

Compatible controls and accessories:

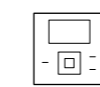

Wired control with programmer
PC-ARFP1E



Noise attenuator
SLT-30-200-L600
SLT-30-250-L600
SLT-30-300-L600
SLT-30-355-L600
SLT-30-450-L600



High-efficiency filter
HEF-252
HEF-502
HEF-802

HEF-1002
HEF-1502
HEF-2002

Econofresh

Free cooling for duct units



EF-456N1E

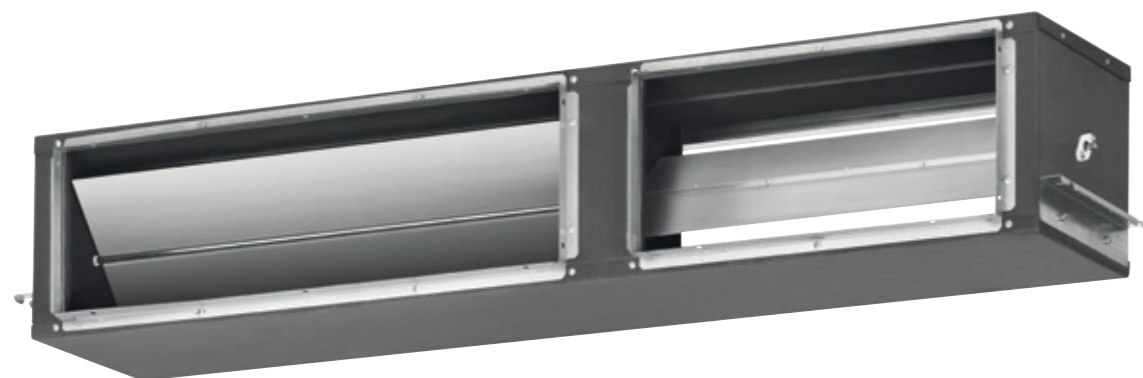

Free cooling

Energy savings are achieved by taking advantage of the outside air when the outdoor air temperature is below the indoor setting temperature.

System Free ducted units

The Econofresh kit connects to RPI System Free series 4, 5 and 6 HP duct units.

Operation by enthalpy control

An enthalpy sensor can be installed in the fresh air supply duct to improve free cooling regulation and control. The amount of fresh and recirculated air is controlled by input air enthalpy instead of temperature, resulting in much more precise, comfortable control.

Operation via CO₂ sensor

A CO₂ sensor that regulates the amount of fresh air to be supplied indoors can be installed to guarantee high air quality.

Versatile operation

The system can operate in two modes in order to meet different user needs: "standard", ideal for intermediate seasons (spring and autumn), and "all fresh", ideal for buildings with a high internal load all year round.

Thermo on control

Function available in either of the two operation modes, ensuring the outdoor unit comes on if the free cooling cannot reach the required conditions.

Adjustable minimum ventilation

A minimum air flow renewal % can be set, regardless of temperature conditions.

Energy savings

Studies carried out using specific energy simulation software have estimated savings of 40% thanks to this use of outside air, compared to the same installation without Econofresh.

Econofresh

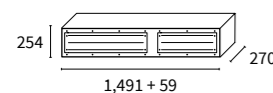

EF-4561E

Econofresh

Free cooling unit		EF-4561E
Combinable indoor unit model		RPI-(4.0/5.0/6.0)FSN5E
Dimensions (H x W x D)	mm	254x1,491+59x270
Weight	kg	13.7
Number of attenuator motors		1
Temperature sensor included		Outdoor air input thermistor

Air renewal

Compatible controls and accessories:

 **Wired control with programmer**
PC-ARFP1E

There is not one space or project like another. Every day your customers propose a different challenge, therefore, we have expanded our range of chillers and commercial heat pumps to suit all your projects regardless of the size or the demands of performance, reliability and precision.





Chillers

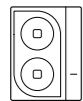
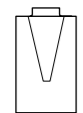
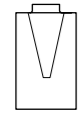

Quick selection table

Chillers

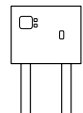
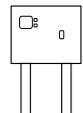
	Nominal cooling power range (kW)	
Samurai S 	11.2 - 18	
Samurai M cooling only 	44.3 - 255	4,080
Samurai M heat pump 	44.3 - 255	4,080
Samurai L air-water cooling only 	160 - 360	2,880
Samurai L air-water heat pump 	150 - 340	2,720
Samurai L water-water 	140 - 250	2,000
Samurai L air-water remote condensation 	135 - 215	1,720

With only one module Combining modules

Benefits Chillers

1 Modular design that adapts to each space



Thanks to their modular design, Hitachi chillers are ideal for quick, compact installations where the machines must adapt to the space available. The high-efficiency units must be adaptable to reach the required power, thereby guaranteeing continued operation in the event of partial failure.

2 Accurate temperature control

The combination of Hitachi's "continuous capacity control compressor" and exclusive electronic controls allows precise control of the water output temperature, regardless of the cooling load, which is particularly important in industrial processes.

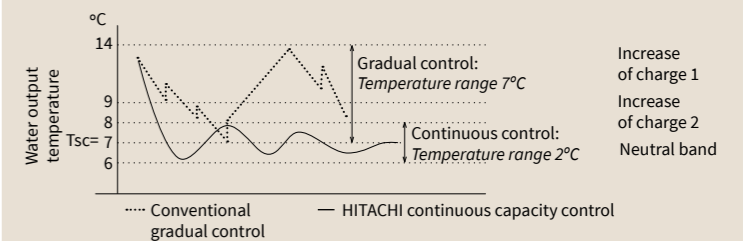

3 Maximum safety

Hitachi chillers feature the latest technology in order to ensure fault-free operation and maximum safety. The improved safety functions include smart defrosting, automatic restart after power failure, anti-freeze protection, automatic on/off fan cycle for greater protection from snow, and remote control of alarms.

4 High-efficiency, Tier 2 compliant (2021)



High levels of efficiency in both cooling and heating modes. Meets or exceeds all Tier 2 Ecodesign requirements for:
 Reg. 813/2013 for heat pumps (2017)
 Reg. 1095/2015 for chillers for medium temperature industrial processes (2018)
 Reg. 2016/2281 for comfort cooling and for high-temperature industrial processes (2021).

5 Wide range of working temperatures

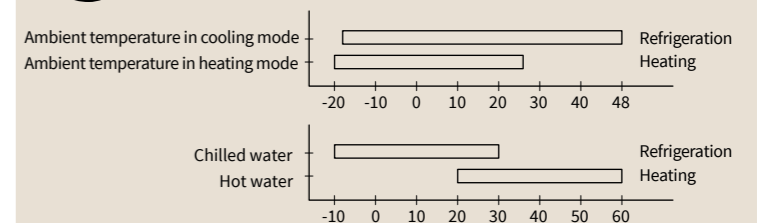

Depending on the model, the units can produce cold water from -10 to 30°C and hot water from 25 to 60°C. Furthermore, operation remains unchanged with outside temperatures of -17.8 to 48°C in cooling and -20 to 25°C in heating, depending on the model.

Samurai S Heat Pump

Scroll inverter chiller

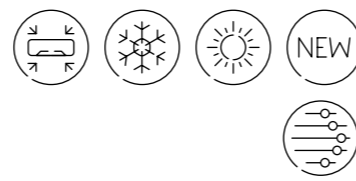

Samurai S RHMA-AVN

Heat Pump models			RHMA 4AVN	RHMA 5AVN	RHMA 6AVN	RHMA 7AVN
Capacity	Cooling (nominal)	kW	11.2	14.0	15.5	18.0
	Heating (nominal)		10.9	13.1	15.4	18.5
EER			2.79	2.70	2.78	2.56
COP			3.00	3.06	3.29	2.94
ESEER			4.34	4.63	4.81	4.74
SEER cooling for comfort (variable flow temp.)			4.05	4.32	4.52	4.42
SCOP			3.47	3.55	4.02	3.90
Sound power (cooling)	Complete charge	dB(A)	68	70	70	74
	Low sound	dB(A)	64	65	65	69
N° and type of compressor/n° of circuits			1 - DC Inverter	1 - DC Inverter	1 - DC Inverter	1 - DC Inverter
Refrigerant			R410A	R410A	R410A	R410A
Refrigerant charge		kg	2.8	3.3	3.9	4.0
Water exchanger type			Plates	Plates	Plates	Plates
Nominal flow rate	Cooling	l/s	0.52	0.66	0.75	0.82
	Heating	l/s	0.56	0.67	0.79	1.03
Water pipe diameter		inches	1	1	1	1
Fan motor			BLDC	BLDC	BLDC	BLDC
Number of fans			2	2	2	2
Outside operating temperature	Cooling	°C	-5 to 48	-5 to 48	-5 to 48	-5 to 48
	Heating	°C	-20 to 25	-20 to 25	-20 to 25	-20 to 25
Water production temperatures	Cooling	°C	5 to 15	5 to 15	5 to 15	5 to 15
	Heating	°C	30 to 52	30 to 52	30 to 52	30 to 52
Electrical power			1N ~200V 50 Hz	1N ~200V 50 Hz	1N ~200V 50 Hz	1N ~200V 50 Hz
Consumption	Cooling		4.0	5.3	5.7	7.0
	Heating	kW	3.7	4.3	4.7	6.3
Maximum current at 400V		A	22.1	30	30	32.8
Dimensions without hydraulic kit (H x W x D)		mm	1,320×995×360	1,320×995×360	1,320×995×360	1,320×995×360
Operating weight		kg	126	128	141	141

Up to 4 combinable modules

This system can be used to combine up to 4 modules of up to 18 kW under a single control for large spaces.

Exceeds Tier 2 requirements

High levels of efficiency in both cooling and heating modes. Exceeds all Tier 2 Ecodesign requirements. Reg. 2016/2281 for comfort cooling and for high-temperature industrial processes (2021).

Built-in hydraulic kits

Pump and flow switch assembled at factory. The safety valve, water filter and automatic balancing valve are shipped separately and assembled at start-up.

High-power fans

The fan motor can provide pressure up to 30Pa to prevent air flow recirculation. (Fig. 1)

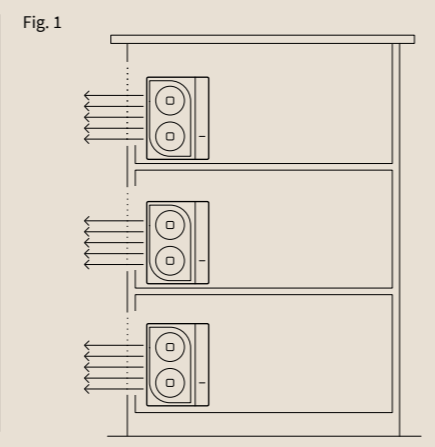

Heat Pump models

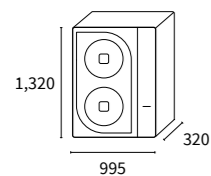

RHMA 4AVN
RHMA 5AVN
RHMA 6AVN
RHMA 7AVN



Samurai M Cooling Only

Scroll inverter chiller

Samurai M Cooling Only



Very compact size

The Samurai M's compact size makes it ideal for replacements, as it fits almost anywhere.

Exceeds Tier 2 requirements

High levels of efficiency in both cooling and heating modes. Exceeds all Tier 2 Ecodesign requirements. Reg. 2016/2281 for comfort cooling and for high-temperature industrial processes (2021).

EC fans. Less noise and more efficiency

Electronically commutated fans use more efficient motors and have better aerodynamics, improving the performance of the whole system while also reducing noise levels, especially at partial charge.

Very low noise level

All models are available in a "low noise" version for optimal user comfort.

Extended operational limits

The system includes operation in cooling mode down to -17°C and production of cold water down to -8°C as standard.

High performance as standard

Built-in Bacnet/Modbus/N2 gateway, electronic expansion valve, flow switch, water filter, etc.

Cooling-only models

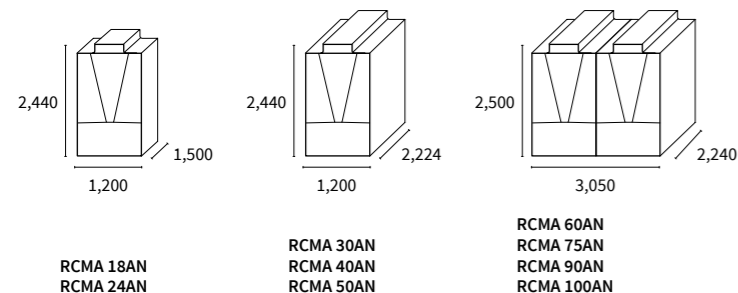

Samurai M RCMA-AN

Cooling Only models		RCMA 18AN		RCMA 24AN		RCMA 30AN		RCMA 40AN		RCMA 50AN	
		Standard	Low noise	Standard	Low noise	Standard	Low noise	Standard	Low noise	Standard	Low noise
Capacity	Cooling (nominal) kW	44.8	41.31	60.4	56.8	77.5	75.0	99.1	92.0	122.8	118.2
EER		2.93	2.93	2.84	2.90	3.13	3.11	3.05	3.05	3.01	2.94
ESEER		5.31	5.36	5.01	5.16	5.10	5.18	5.10	5.24	4.98	5.16
SEER cooling for comfort (fixed flow temp.)		4.25	4.27	4.29	4.37	4.42	4.44	4.40	4.30	4.36	4.38
"SEER cooling for comfort (variable flow temp.)		4.38	4.61	4.50	4.71	4.43	4.24	4.24	4.43	4.42	4.37
SEPR _{HT}		3.76	3.77	3.77	3.89	3.91	3.83	3.51	3.57	3.58	3.47
SEPR _{HT}		5.70	5.96	5.96	6.13	5.58	5.59	5.67	6.08	5.84	5.87
Sound power (cooling)	dB(A)	80	75	82	77	81	77	84	79	85	81
Sound pressure (cooling) @ 1 m	dB(A)	66	61	68	63	67	63	69	64	70	66
Sound pressure (cooling) @ 10 m	dB(A)	51	46	53	48	53	49	55	50	56	52
N° and type of compressor/n° of circuits		2 - Scroll/1	2 - Scroll/1	2 - Scroll/1	2 - Scroll/1	3 - Scroll/2	3 - Scroll/2	3 - Scroll/2	3 - Scroll/2	4 - Scroll/2	4 - Scroll/2
Refrigerant		R410A	R410A	R410A	R410A	R410A	R410A	R410A	R410A	R410A	R410A
Refrigerant charge	kg	9.5	9.5	12.3	12.3	8.5+9.1	8.5+9.1	9.5+11	9.5+11	11.4+11.4	11.4+11.4
Capacity control	%	33-100	33-100	25-100	25-100	20-100	20-100	15-100	15-100	12-100	12-100
Water exchanger type		Plates	Plates	Plates	Plates	Plates	Plates	Plates	Plates	Plates	Plates
Nominal flow rate	l/s	2.1	2.2	2.9	2.7	3.7	3.6	4.7	4.4	6.0	6.0
Total pressure drop	kPa	32	32	25	25	23	23	31	31	37	37
Water pipe diameter	inches	2	2	2	2	2 1/2	2 1/2	2 1/2	2 1/2	2 1/2	2 1/2
Fan motor		EC motor	EC motor	EC motor	EC motor	EC motor	EC motor	EC motor	EC motor	EC motor	EC motor
Number of fans		1	1	1	1	2	2	2	2	2	2
Outside operating temperature	°C	-17.8 to 48	-17.8 to 48	-17.8 to 48	-17.8 to 48	-17.8 to 48	-17.8 to 48	-17.8 to 48	-17.8 to 48	-17.8 to 48	-17.8 to 48
Water production temperatures	°C	-8 to 20	-8 to 20	-8 to 20	-8 to 20	-8 to 20	-8 to 20	-8 to 20	-8 to 20	-8 to 20	-8 to 20
Electrical power	V/ph/hz	3N ~400V 50 Hz	3N ~400V 50 Hz	3N ~400V 50 Hz	3N ~400V 50 Hz	3N ~400V 50 Hz	3N ~400V 50 Hz	3N ~400V 50 Hz	3N ~400V 50 Hz	3N ~400V 50 Hz	3N ~400V 50 Hz
Consumption	kW	15.3	14.1	21.3	19.6	24.8	24.1	32.6	30.2	40.8	40.0
Maximum current at 400V	A	35.1	35.1	38.3	38.3	60.9	60.9	71.7	71.7	85.2	85.2
Dimensions without hydraulic kit (H x W x D)	mm	2,440x 1,500x 1,200	2,440x 1,500x 1,200	2,440x 1,500x 1,200	2,440x 1,500x 1,200	2,440x 2,240x 1,200	2,440x 2,240x 1,200	2,440x 2,240x 1,200	2,440x 2,240x 1,200	2,440x 2,240x 1,200	2,440x 2,240x 1,200
Operating weight	kg	587	587	610	610	893	893	920	920	999	999

Cooling Only models		RCMA 60AN		RCMA 75AN		RCMA 90AN		RCMA 100AN	
		Standard	Low noise	Standard	Low noise	Standard	Low noise	Standard	Low noise
Capacity	Cooling kW	161.0	158.0	189.2	181.5	221.0	214.0	255.1	245.0
EER		3.19	3.03	3.08	2.96	3.14	2.96	3.11	2.96
ESEER		5.09	4.72	5.02	5.16	4.99	5.06	4.75	4.92
SEER cooling for comfort		4.36	4.06	4.45	4.39	4.40	4.38	4.24	4.35
SEER cooling for comfort		4.24	4.06	4.28	4.39	4.17	4.38	4.34	4.68
SEPR _{HT}		2.79	2.75	2.70	2.69	3.78	tbv	3.70	3.77
SEPR _{HT}		5.97	5.76	5.81	5.75	5.99	5.99	6.02	5.98
Sound power (cooling)	dB(A)	87	82	88	83	88	83	89	84
Sound pressure (cooling) @ 1 m	dB(A)	71	66	71	66	72	67	73	68
Sound pressure (cooling) @ 10 m	dB(A)	58	53	58	53	59	54	60	55
N° and type of compressor/n° of circuits		5 - Scroll/3	5 - Scroll/3	6 - Scroll/3	6 - Scroll/3	7 - Scroll/4	7 - Scroll/4	8 - Scroll/4	8 - Scroll/4
Refrigerant		R410A	R410A	R410A	R410A	R410A	R410A	R410A	R410A
Refrigerant charge	kg	9.5+10+10	9.5+10+10	11+10.5+10.5	11+10.5+10.5	9.5+11+11.4+11.4	9.5+11+11.4+11.4	11.4+11.4+11.4	11.4+11.4+11.4
Capacity control	%	10-100	10-100	8-100	8-100	7-100	7-100	6-100	6-100
Water exchanger type		Plates	Plates	Plates	Plates	Plates	Plates	Plates	Plates
Nominal flow rate	l/s	7.6	7.6	9.0	8.6	10.5	10.5	12.1	11.8
Total pressure drop	kPa	25	25	31	31	40	40	38	38
Water pipe diameter	inches	4	4	4	4	4	4	4	4
Fan motor		EC motor	EC motor	EC motor	EC motor	EC motor	EC motor	EC motor	EC motor
Number of fans		3	3	3	3	4	4	4	4
Outside operating temperature	°C	-17.8 to 48	-17.8 to 48	-17.8 to 48	-17.8 to 48	-17.8 to 48	-17.8 to 48	-17.8 to 48	-17.8 to 48
Water production temperatures	°C	-8 to 20	-8 to 20	-8 to 20	-8 to 20	-8 to 20	-8 to 20	-8 to 20	-8 to 20
Electrical power	V/ph/hz	3N ~400V 50 Hz	3N ~400V 50 Hz	3N ~400V 50 Hz	3N ~400V 50 Hz	3N ~400V 50 Hz	3N ~400V 50 Hz	3N ~400V 50 Hz	3N ~400V 50 Hz
Consumption	kW	50.6	52.0	61.2	61.3	70.7	72.4	82.0	82.8
Maximum current at 400V	A	119.5	119.5	133.1	133.1	166.4	166.4	179.9	179.9
Dimensions without hydraulic kit (H x W x D)	mm	2,500x 2,240x3,050	2,500x 2,240x3,050	2,500x 2,240x3,050	2,500x 2,240x3,050	2,500x 2,240x3,050	2,500x 2,240x3,050	2,500x 2,240x3,050	2,500x 2,240x3,050
Operating weight	kg	1,922	1,922	2,003	2,003	2,235	2,235	2,316	2,316

Compatible controls and accessories:

- Condenser battery protection grilles
- Wired remote controller
- 1" or 2" spring anti-vibration mounts
- Neoprene anti-vibration mounts
- Others:
- Modular kit: required for modular applications.

Samurai M Heat Pump

Scroll inverter chiller

Samurai M Heat Pump

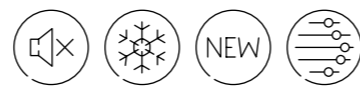

Samurai M RHMA-AN

Chillers

Heat Pump models			RHMA18AN		RHMA24AN		RHMA30AN		RHMA 40AN		RHMA 50AN		
			Standard	Low noise	Standard	Low noise	Standard	Low noise	Standard	Low noise	Standard	Low noise	
Capacity	Cooling (nominal)	kW	44.82	41.31	60.2	56.82	78.2	75.2	99.13	91.65	122.77	118.21	
	Heating (nominal)		49.00	45.00	60.00	55.00	87.00	84.00	99.00	91.00	131.00	125.00	
EER			2.92	2.92	2.83	2.90	3.15	3.11	3.05	3.04	3.01	2.94	
COP			2.87	2.99	2.87	3.01	3.09	3.15	3.01	3.07	2.78	2.85	
ESEER			5.31	5.36	5.01	5.16	5.10	5.18	5.10	5.24	4.98	5.16	
"SEER cooling for comfort (fixed flow temp)"			4.25	4.27	4.29	4.37	4.40	4.40	4.40	4.30	4.36	4.38	
"SEER cooling for comfort (variable flow temp)"			4.38	4.61	4.50	4.71	4.43	4.24	4.24	4.43	4.42	4.37	
SEPR _{HT}			3.76	3.77	3.77	3.89	3.91	3.83	3.53	3.57	3.58	3.47	
SEPR _{HT}			5.70	5.96	5.96	6.13	5.58	5.59	5.69	tbc	5.84	5.87	
SCOP			3.45	3.43	3.44	3.45	3.40	3.40	3.41	3.35	3.54	3.39	
Class	Heating		A+	A+	A+	A+	A+	A+	A+	A+	A+	A+	
Sound power (cooling)	Cooling	dB(A)	80	75	83	78	81	77	84	79	84	80	
	Heating	dB(A)	82	77	84	76	84	76	85	80	89	81	
Sound pressure (cooling) @ 1 m	Cooling	dB(A)	66	61	69	63	66	62	69	64	69	65	
	Heating	dB(A)	68	63	70	65	69	65	70	65	74	68	
Sound pressure (cooling) @ 10 m	Cooling	dB(A)	51	46	54	49	52	48	55	50	56	52	
	Heating	dB(A)	53	48	55	50	55	51	56	51	60	55	
N° and type of compressor/n° of circuits			2 - Scroll/ 1	2 - Scroll/ 1	2 - Scroll/ 1	2 - Scroll/ 1	3 - Scroll/ 2	3 - Scroll/ 2	3 - Scroll/ 2	3 - Scroll/ 2	4 - Scroll/ 2	4 - Scroll/ 2	
Refrigerant			R410A	R410A	R410A	R410A	R410A	R410A	R410A	R410A	R410A	R410A	
Refrigerant charge			kg	9.5	9.5	12.3	12.3	8.5+9.1	8.5+9.1	9.5+11	9.5+11	11.4+11.4	11.4+11.4
Capacity control			%	33-100	33-100	25-100	25-100	20-100	20-100	15-100	15-100	12-100	12-100
Water exchanger type			Plates	Plates	Plates	Plates	Plates	Plates	Plates	Plates	Plates	Plates	
Nominal flow rate	Cooling	l/s	2.1	2.0	2.9	2.7	3.7	3.6	4.7	4.4	5.8	5.6	
	Heating	l/s	2.4	2.2	2.9	2.7	4.2	4.0	4.8	4.4	6.3	6.0	
Total pressure drop	Cooling	kPa	32	32	25	25	27	23	30	30	36	36	
	Heating	kPa	37	32	24	21	36	33	28	29	41	37	
Water pipe diameter			inches	2	2	2	2	2 ½	2 ½	2 ½	2 ½	2 ½	
Fan motor			EC motor	EC motor	EC motor	EC motor	EC motor	EC motor	EC motor	EC motor	EC motor	EC motor	
Number of fans			1	1	1	1	2	2	2	2	2	2	
Outside operating temperature	Cooling	°C	-17.8 to 48	-17.8 to 48	-17.8 to 48	-17.8 to 48	-17.8 to 48	-17.8 to 48	-17.8 to 48	-17.8 to 48	-17.8 to 48	-17.8 to 48	
	Heating	°C	-15 to 25	-15 to 25	-15 to 25	-15 to 25	-15 to 25	-15 to 25	-15 to 25	-15 to 25	-15 to 25	-15 to 25	
Water production temperatures	Cooling	°C	5 to 20	5 to 20	5 to 20	5 to 20	5 to 20	5 to 20	5 to 20	5 to 20	5 to 20	5 to 20	
	Heating	°C	25 to 55	25 to 55	25 to 55	25 to 55	25 to 55	25 to 55	25 to 55	25 to 55	25 to 55	25 to 55	
Electrical power			3N ~400V 50 Hz	3N ~400V 50 Hz	3N ~400V 50 Hz	3N ~400V 50 Hz	3N ~400V 50 Hz	3N ~400V 50 Hz	3N ~400V 50 Hz	3N ~400V 50 Hz	3N ~400V 50 Hz	3N ~400V 50 Hz	
Consumption	Cooling		15.29	14.08	21.27	19.61	24.75	24.11	32.55	30.16	40.84	40.04	
	Heating	kW	15.50	14.30	21.50	19.80	26.90	25.90	31.30	29.00	47.30	43.80	
Maximum current at 400V			A	35.1	35.1	38.3	38.3	60.9	60.9	71.7	71.7	85.2	85.2
Dimensions without hydraulic kit (H x W x D)			mm	2,440x 1,500x1,200	2,440x 1,500x1,200	2,440x 1,500x1,200	2,440x 1,500x1,200	2,440x 2,240x1,200	2,440x 2,240x1,200	2,440x 2,240x1,200	2,440x 2,240x1,200	2,440x 2,240x1,200	
Operating weight			kg	587	587	610	610	893	893	920	920	999	999

Very compact size

The Samurai M's compact size makes it ideal for replacements, as it fits almost anywhere.

Exceeds Tier 2 requirements

High levels of efficiency in both cooling and heating modes. Exceeds all Tier 2 Ecodesign requirements. Reg. 2016/2281 for comfort cooling and for high-temperature industrial processes (2021).

EC fans. Less noise and more efficiency

Electronically commutated fans use more efficient motors and have better aerodynamics, improving the performance of the whole system while also reducing noise levels, especially at partial charge.

Very low noise level

All models are available in a "low noise" version for optimal user comfort.

Extended operational limits

The system includes operation in cooling mode down to -17°C as standard.

High performance as standard

Built-in Bacnet/Modbus/N2 gateway, electronic expansion valve, flow switch, water filter, etc.

Cold-only models

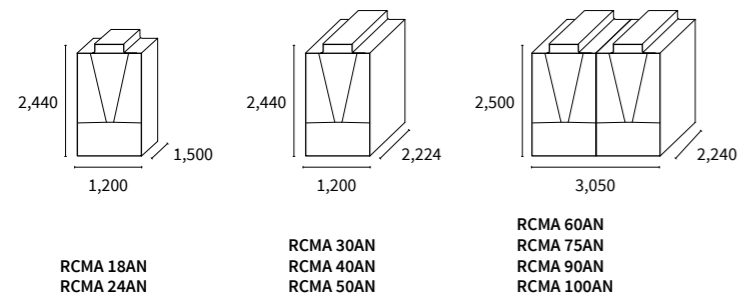

Compatible controls and accessories:

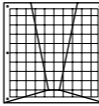
- 

Condenser battery protection grilles
- 

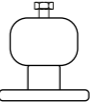
Wired remote controller
- 

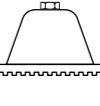
1" or 2" spring anti-vibration mounts
- 

Neoprene anti-vibration mounts
- Others:
- Modular kit: required for modular applications.

Samurai M RHMA-AN

Samurai M Heat Pump

Heat Pump models			RHMA60AN		RHMA 75AN		RHMA 90AN		RHMA 100AN	
			Standard	Low noise	Standard	Low noise	Standard	Low noise	Standard	Low noise
Capacity	Cooling	kW	161.00	158.00	189.12	181.48	222.20	214.00	255.08	245.74
	Heating		161.00	156.00	190.00	181.00	230.00	223.00	256.00	244.00
EER			3.16	3.03	3.08	2.96	3.14	2.96	3.11	2.97
COP			3.10	3.10	3.05	3.08	3.07	3.07	3.05	3.09
ESEER			5.09	4.72	5.02	5.16	4.99	5.06	4.75	4.92
SEER cooling for comfort (fixed flow temp.)			4.36	4.06	4.45	4.39	4.41	4.38	4.23	4.34
SEER cooling for comfort (variable flow temp.)			4.24	4.06	4.28	4.39	4.17	4.38	4.34	4.68
SEPR _{HT}			2.79	2.75	2.70	2.69	3.78	tbc	3.70	3.77
SEPR _{HT}			5.97	5.76	5.81	5.75	5.99	5.99	6.02	5.98
SCOP			3.32	3.54	3.36	3.53	3.47	3.40	3.30	3.30
Class	Heating		A+	A+	A+	A+	A+	A+	A+	A+
Sound power (cooling)	Cooling	dB(A)	87	82	88	83	88	83	89	84
	Heating	dB(A)	87	82	88	83	89	84	90	84
Sound pressure (cooling) @ 1 m	Cooling	dB(A)	71	66	72	67	72	67	73	68
	Heating	dB(A)	71	66	72	67	73	68	74	68
Sound pressure (cooling) @ 10 m	Cooling	dB(A)	58	53	58	54	59	54	60	55
	Heating	dB(A)	58	53	59	54	60	54	61	55
N° and type of compressor/n° of circuits			5 - Scroll/ 3	5 - Scroll/ 3	6 - Scroll/ 3	6 - Scroll/ 3	7 - Scroll/ 4	7 - Scroll/ 4	8 - Scroll/ 4	8 - Scroll/ 4
Refrigerant			R410A	R410A	R410A	R410A	R410A	R410A	R410A	R410A
Refrigerant charge		kg	9.5+10+10	9.5+10+10	11+10.5+10.5	11+10.5+10.5	9.5+11+11.4+11.4	9.5+11+11.4+11.4	11.4+11.4+11.4+11.4	11.4+11.4+11.4+11.4
Capacity control		%	10-100	10-100	8-100	8-100	7-100	7-100	6-100	6-100
Water exchanger type			Plates	Plates	Plates	Plates	Plates	Plates	Plates	Plates
Nominal flow rate	Cooling	l/s	7.6	7.6	9.0	8.6	10.6	10.3	12.1	11.8
	Heating	l/s	7.8	7.5	9.2	8.7	11.1	10.8	12.3	11.8
Total pressure drop	Cooling	kPa	25	25	32	32	41	40	38	38
	Heating	kPa	27	25	34	30	47	44	39	39
Water pipe diameter		inches	4	4	4	4	4	4	4	4
Fan motor			EC motor	EC motor	EC motor	EC motor	EC motor	EC motor	EC motor	EC motor
Number of fans			3	3	3	3	4	4	4	4
Outside operating temperature	Cooling	°C	-17.8 to 48	-17.8 to 48	-17.8 to 48	-17.8 to 48	-17.8 to 48	-17.8 to 48	-17.8 to 48	-17.8 to 48
	Heating	°C	-15 to 25	-15 to 25	-15 to 25	-15 to 25	-15 to 25	-15 to 25	-15 to 25	-15 to 25
Water production temperatures	Cooling	°C	5 to 20	5 to 20	5 to 20	5 to 20	5 to 20	5 to 20	5 to 20	5 to 20
	Heating	°C	25 to 55	25 to 55	25 to 55	25 to 55	25 to 55	25 to 55	25 to 55	25 to 55
Electrical power		V/ph/hz	3N ~400V 50 Hz	3N ~400V 50 Hz	3N ~400V 50 Hz	3N ~400V 50 Hz	3N ~400V 50 Hz	3N ~400V 50 Hz	3N ~400V 50 Hz	3N ~400V 50 Hz
Consumption	Cooling		50.60	52.00	61.18	61.28	70.40	72.40	82.00	82.84
	Heating	kW	51.80	50.00	62.30	58.70	74.90	72.70	79.00	76.80
Maximum current at 400V		A	119.5	119.5	133.1	133.1	166.4	166.4	179.9	179.9
Dimensions without hydraulic kit (H x W x D)		mm	2,500x	2,500x	2,500x	2,500x	2,500x	2,500x	2,500x	2,500x
			2,240x3,050	2,240x3,050	2,240x3,050	2,240x3,050	2,240x3,050	2,240x3,050	2,240x3,050	2,240x3,050
Operating weight		kg	1,922	1,922	2,003	2,003	2,235	2,235	2,316	2,316



Samurai L

Air Cooled, Hi-Efficiency, Cooling Only

Double screw compressor, continuous capacity control

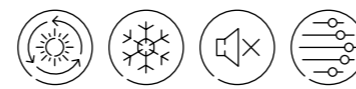

Accurate temperature control

The combination of Hitachi's "continuous capacity control compressor" and exclusive electronic controls allows precise control of the water outlet temperature, regardless of the cooling load, which is particularly important in industrial processes.

Modular design

The combination of up to 8 modules allows production to be adapted precisely to the needs of the installation.

Very compact dimensions

The new 80 and 90 HP modules (with 6 fans) help reduce the footprint required for the machine.

(Fig. 1)

Two operating modes

There are two standard operating modes configurable in the system:
 -Standard mode
 -High-efficiency mode

Chilled water output from -10°C to 30°C

The output temperature range for the chilled water has been increased during cooling, offering the option of high and low water output temperatures.

(Fig. 2)

Heat recovery option

Optionally, the unit can be ordered with a partial heat recovery device.

Fig. 1

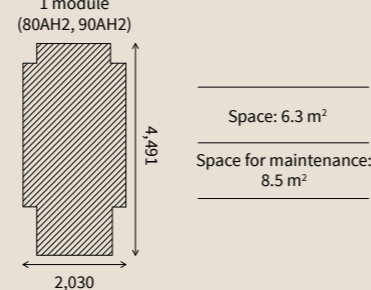
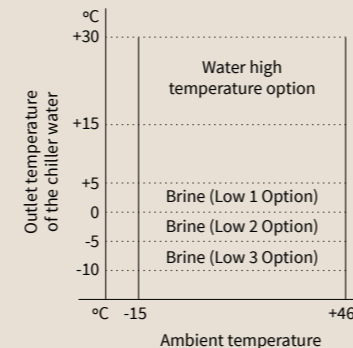
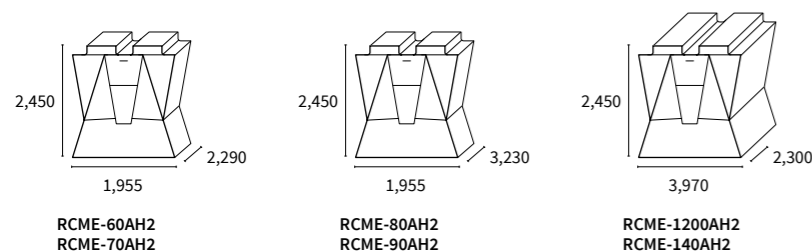

Fig. 2



Cooling Only models



Samurai L RCME-AH2

Cooling Only models			RCME-60AH2	RCME-70AH2	RCME-80AH2	RCME-90AH2	RCME-1200AH2	RCME-140AH2
Capacity	Cooling (nominal)	kW	160	180	205	225	320	360
EER			3.14	3.14	3.16	3.20	3.14	3.14
SEER			4.11	4.13	4.12	4.12	4.18	4.19
SEPR _{HT}			3.24	3.24	3.26	3.30	3.25	3.25
SEPR _{HT}			5.11	5.11	5.15	5.20	5.13	5.13
Sound power (standard mod. *)		dB(A)	96	97	98	99	99	100
Sound pressure		dB(A)	83	84	85	86	86	87
IP Rating			IPX4	IPX4	IPX4	IPX4	IPX4	IPX4
N° and type of compressor/n° of circuits			1 - Semi-hermetic double screw/ 1	1 - Semi-hermetic double screw/ 1	1 - Semi-hermetic double screw/ 1	1 - Semi-hermetic double screw/ 1	2 - Semi-hermetic double screw/ 2	2 - Semi-hermetic double screw/ 2
Refrigerant			R134A	R134A	R134A	R134A	R134A	R134A
Refrigerant charge		kg	29	36	47	47	58	72
Capacity control		%	25-100	25-100	25-100	25-100	25-100	25-100
Water flow	Cooling (Min/Nom/Max)	m3/h	17.2-27.5-39.3	19.4-31.0-44.2	22.0-35.3-50.4	24.2-38.7-55.3	34.4-55.0-78.6	38.7-61.9-88.5
Water pipe diameter		inches	1/2	1/2	1/2	1/2	1/2	1/2
Minimum system water volume		m3	0.77	0.76	0.98	0.95	1.54	1.52
Fan motor			EC motor	EC motor	EC motor	EC motor	EC motor	EC motor
Number of fans			4	4	6	6	8	8
Outside operating temperatures	Cooling	°C	-15 to 46	-15 to 46	-15 to 46	-15 to 46	-15 to 46	-15 to 46
Water production temperatures	Cooling - Standard	°C	5 to 15	5 to 15	5 to 15	5 to 15	5 to 15	5 to 15
	Cooling - Low option	°C	-10 to 5	-10 to 5	-10 to 5	-10 to 5	-10 to 5	-10 to 5
	Cooling - High option	°C	15 to 30	15 to 30	15 to 30	15 to 30	15 to 30	15 to 30
Electrical power			3N ~400V 50 Hz	3N ~400V 50 Hz	3N ~400V 50 Hz	3N ~400V 50 Hz	3N ~400V 50 Hz	3N ~400V 50 Hz
Consumption	Cooling (nominal)	kW	51.0	57.3	64.9	70.3	101.9	114.6
Current (maximum-start-up)		A	118-240	132-240	140-240	143-240	237-259	264-262
Dimensions (H x W x D)		mm	2,450x1,955x2,290	2,450x1,955x2,290	2,450x1,955x3,230	2,450x1,955x3,230	2,450x3,970x2,300	2,450x3,970x2,300
Weight		kg	1,300	1,340	1,590	1,680	2,640	2,720

*In the low noise option the values are reduced by 3 dB(A)
 *In the very low noise level option the values are reduced by 5 dB(A)
 *In the extra low noise level option the values are reduced by 8 dB(A)

Options and accessories:

See page 214.

Samurai L

Air Cooled, Hi-Efficiency with Heat Pump

Double screw compressor, continuous capacity control

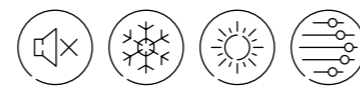

Samurai L RHME-AH2

Heat Pump models			RHME-60AH2	RHME-70AH2	RHME-80AH2	RHME-90AH2	RHME-120AH2	RHME-140AH2
Capacity	Cooling (nominal)	kW	150	170	195	210	300	340
	Heating (nominal)	kW	145	145	185	185	290	290
EER			2.95	2.95	2.97	3.01	2.95	2.95
COP			2.83	2.83	2.85	2.85	2.83	2.83
SEER			3.88	3.88	3.92	3.96	3.94	3.93
SEPR _{HT}			3.24	3.24	3.26	3.30	3.25	3.25
SEPR _{HT}			5.11	5.11	5.15	5.20	5.13	5.13
SCOP _{HT}			3.22	3.22	3.25	3.25	3.22	3.22
Sound power (standard mod. *)		dB(A)	96	97	98	99	99	100
Sound pressure		dB(A)	83	84	85	86	86	87
IP Rating			IPX4	IPX4	IPX4	IPX4	IPX4	IPX4
N° and type of compressor/n° of circuits			1 - Semi-hermetic double screw/ 1	1 - Semi-hermetic double screw/ 1	1 - Semi-hermetic double screw/ 1	1 - Semi-hermetic double screw/ 1	2 - Semi-hermetic double screw/ 2	2 - Semi-hermetic double screw/ 2
Refrigerant			R134A	R134A	R134A	R134A	R134A	R134A
Refrigerant charge		kg	37	39	49	49	74	78
Capacity control		%	25-100	25-100	25-100	25-100	25-100	25-100
Water flow	Cooling (Min/Nom/Max)	m3/h	16.1-25.8-36.9	18.3-29.2-41.8	21.0-33.5-47.9	22.6-36.1-51.6	32.3-51.6-73.7	36.6-58.5-83.5
	Heating (nominal)		24.9	24.9	31.8	31.8	49.9	49.9
Water pipe diameter		inches	1/2	1/2	1/2	1/2	1/2	1/2
Minimum system water volume		m3	0.72	0.72	0.94	0.89	1.44	1.44
Fan motor			EC motor	EC motor	EC motor	EC motor	EC motor	EC motor
Number of fans			4	4	6	6	8	8
Outside operating temperatures	Cooling (DB)	°C	-15 to 46	-15 to 46	-15 to 46	-15 to 46	-15 to 46	-15 to 46
	Heating (DB)	°C	-9.5 to 21	-9.5 to 21	-9.5 to 21	-9.5 to 21	-9.5 to 21	-9.5 to 21
Water production temperatures	Cooling - Standard	°C	5 to 15	5 to 15	5 to 15	5 to 15	5 to 15	5 to 15
	Cooling - Low option	°C	-10 to 5	-10 to 5	-10 to 5	-10 to 5	-10 to 5	-10 to 5
	Cooling - High option	°C	15 to 30	15 to 30	15 to 30	15 to 30	15 to 30	15 to 30
	Heating	°C	35 to 55	35 to 55	35 to 55	35 to 55	35 to 55	35 to 55
	Heating	°C	35 to 55	35 to 55	35 to 55	35 to 55	35 to 55	35 to 55
Electrical power			3N ~400V 50 Hz	3N ~400V 50 Hz	3N ~400V 50 Hz	3N ~400V 50 Hz	3N ~400V 50 Hz	3N ~400V 50 Hz
Consumption	Cooling (nominal)	kW	50.8	57.6	65.7	69.8	101.7	115.3
	Heating (nominal)	kW	51.2	51.2	64.9	64.9	102.5	102.5
Current (maximum-start-up)		A	119-240	133-240	140-240	143-240	238-259	266-262
Dimensions (H x W x D)		mm	2,450x1,955x2,290	2,450x1,955x2,290	2,450x1,955x3,230	2,450x1,955x3,230	2,450x3,970x2,300	2,450x3,970x2,300
Weight		kg	1,400	1,420	1,680	1,760	2,820	2,880

Accurate temperature control

The combination of Hitachi's "continuous capacity control compressor" and exclusive electronic controls allows precise control of the water output temperature, regardless of the cooling load, which is particularly important in industrial processes.

(Fig. 1)

Modular design

The combination of up to 8 modules allows precise adaptation to the requirements of the installation.

Very compact dimensions

The new 80 and 90 HP modules (with 6 fans) help reduce the footprint required for the machine.

(Fig. 2)

Two operating modes

There are two standard operating modes configurable in the system:

- Standard mode
- High-efficiency mode

Chilled water from -10°C and hot water up to 55°C

The output temperature range for the chilled water has been increased during cooling, offering the option of high and low water output temperatures. (Fig. 3)

Heat recovery option

Optionally, the unit can be ordered with a partial heat recovery device.

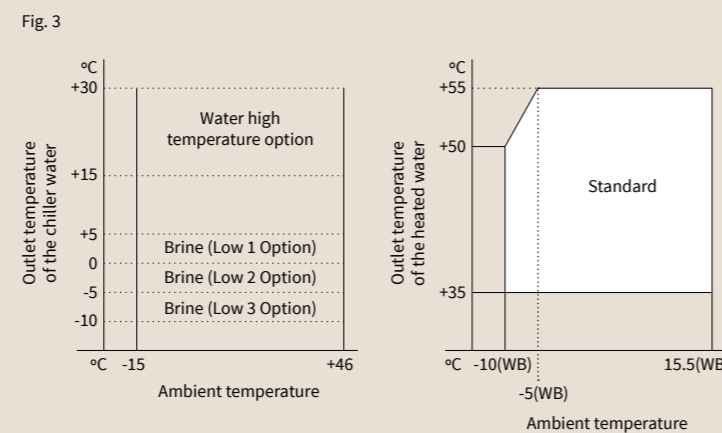
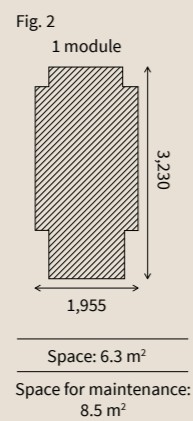
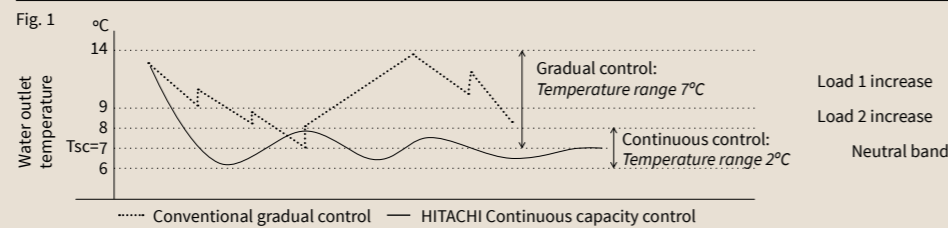

Heat pump models

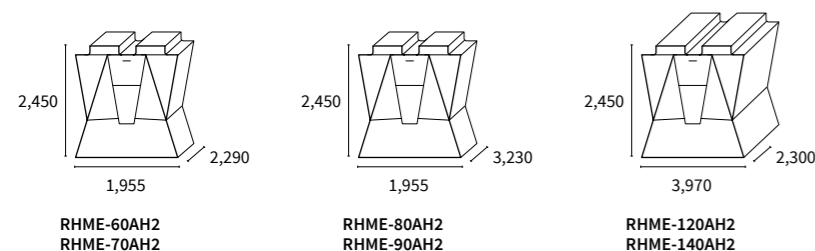

Options and accessories:

See page 214.



Samurai L Water Cooled, Hi-Efficiency

Double screw compressor, continuous capacity control



Continuous capacity control

Hitachi's continuous capacity control system uses advanced electronic controls to position the infinitely variable slide valve on each compressor, thus ensuring accurate control of the charge and, thereby, of the chilled water temperature.

Compact unit

Reduced operating space and easier access to machine rooms. Moreover, the compressor is located in an easily accessible space for more straightforward maintenance.

Accurate temperature control

The combination of Hitachi's "continuous capacity control compressor" and exclusive electronic controls allows precise control of the water output temperature, regardless of the cooling load, which is particularly important in industrial processes.

New compressor

The range incorporates a new double screw compressor with the latest advances in Hitachi screw compressor technology and continuous capacity control from 25% to 100%. This modulation ensures the right charge at all times.

Energy savings of up to 20%

The exclusive continuous capacity control brings energy savings of 15-20% compared to gradual regulation systems, since the cooling load is adjusted more precisely, frequent compressor starts and stops are eliminated, and the system benefits from the high-efficiency of partial load performance.

(Fig. 1)

Cooling only with heat pump option

The system can also work as a heat pump. An optional accessory can be used to regulate water output temperature on the condenser side rather than on the evaporator side.

Fig. 1

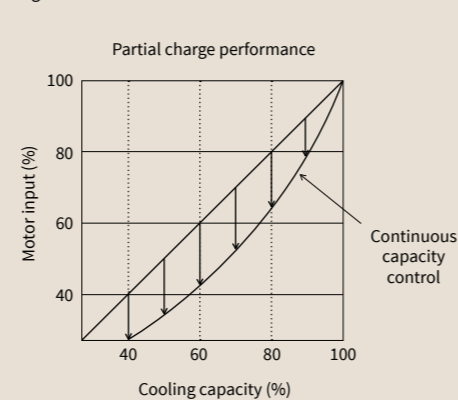

Cooling Only models

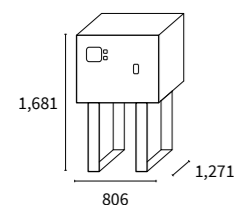

- RCME-40WH1
- RCME-50WH1
- RCME-60WH1
- RCME-70WH1

Samurai L RCME-WH1

		RCME-40WH1	RCME-50WH1	RCME-60WH1	RCME-70WH1	
Capacity	Cooling (nominal)	kW	140	180	220	250
	Heating (nominal)	kW	159.9	205.9	252.9	287.1
EER			5.00	4.96	4.85	4.87
COP			4.79	4.76	4.67	4.69
SEER			5.14	5.46	5.51	5.52
SEPR _{MT}			4.88	4.85	4.89	4.90
SEPR _{HT}			7.58	7.51	7.57	7.59
SCOP _{LT}			5.90	5.86	5.75	5.78
SCOP _{MT}			4.42	4.39	4.32	4.33
Sound power		dB(A)	88	89	90	91
Sound pressure		dB(A)	60	61	62	63
IP Rating			IP2X	IP2X	IP2X	IP2X
N° and type of compressor/n° of circuits			1 - Semi-hermetic double screw/ 1	1 - Semi-hermetic double screw/ 1	1 - Semi-hermetic double screw/ 1	1 - Semi-hermetic double screw/ 1
Refrigerant			R134A	R134A	R134A	R134A
Refrigerant charge		kg	19	20	24	29
Capacity control		%	25-100	25-100	25-100	25-100
Water flow	Cooling (Min/Nom/Max)	m ³ /h	15.1-24.1-52.3	19.4-31.0-67.3	23.7-37.8-82.3	26.9-43.0-83.8
Condensation water flow	(nom-max)	m ³ /h	28.9-62.8	37.2-80.9	45.6-83.8	51.8-83.8
Water pipe diameter		inches	1/2	1/2	1/2	1/2
Minimum system water volume		m ³	0.51	0.65	0.80	0.90
Condenser water temperatures	Cooling	°C	22 to 50	22 to 50	22 to 50	22 to 50
	Heating (optional)	°C	35 to 60	35 to 60	35 to 60	35 to 60
Water production temperatures	Cooling - Standard	°C	5 to 15	5 to 15	5 to 15	5 to 15
	Cooling - Low option	°C	-10 to 5	-10 to 5	-10 to 5	-10 to 5
	Cooling - High option	°C	15 to 25	15 to 25	15 to 25	15 to 25
	Heating	°C	35 to 60	35 to 60	35 to 60	35 to 60
Electrical power			3N ~400V 50 Hz	3N ~400V 50 Hz	3N ~400V 50 Hz	3N ~400V 50 Hz
Consumption	Cooling (nominal)	kW	28.0	36.3	45.4	51.3
	Heating (nominal)	kW	33.4	43.3	54.1	61.2
Current (maximum cooling/start-up)		A	66.2/ 179	84.6/ 240	105/ 240	118/ 240
Current (optional maximum heating/start-up)		A	76.4/ 179	96.2/ 240	119/ 240	135/ 240
Dimensions (H x W x D)		mm	1,681x806x1,271	1,681x806x1,271	1,681x806x1,271	1,681x806x1,271
Weight		kg	860	950	1,040	1,075

Options and accessories:

See page 214.



Samurai L

Condenserless, Hi-Efficiency

Double screw compressor, continuous capacity control

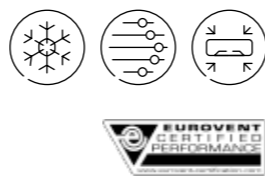

New compressor

The range incorporates a new double screw compressor with the latest advances in Hitachi screw compressor technology and continuous capacity control from 25% to 100%. This modulation ensures the right charge at all times.

Accurate temperature control

The combination of Hitachi's "continuous capacity control compressor" and exclusive electronic controls allows precise control of the water output temperature, regardless of the cooling load, which is particularly important in industrial processes.

(Fig. 1)

Two operating modes

There are two standard operating modes configurable in the system:
 -Standard mode
 -High-efficiency mode

Less maintenance space

The compressor is in a lower position, making disassembly easier from the front of the unit, thereby reducing the space for maintenance.

Condenserless

The system is supplied without a condenser, allowing you to select the one best suited for the specific installation and application.

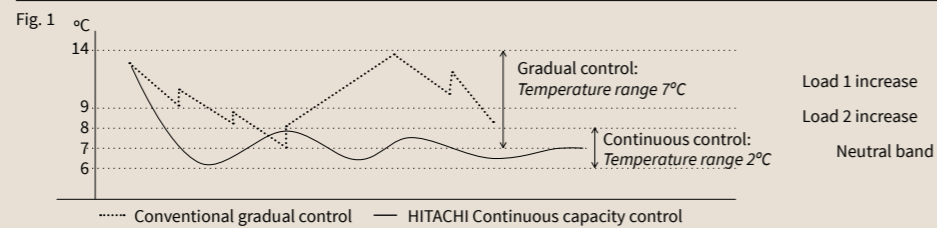

Cold-only models

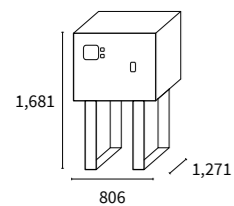

RHME-40CLH1
 RHME-50CLH1
 RHME-60CLH1

Samurai L RCME-CLH1

			RHME-40CLH1	RHME-50CLH1	RHME-60CLH1
Capacity	Cooling (nominal)	kW	135	175	215
EER			4.22	4.19	4.10
Sound power		dB(A)	88	89	90
Sound pressure		dB(A)	60	61	62
IP Rating			IP2X	IP2X	IP2X
N° and type of compressor/n° of circuits			1 - Semi-hermetic double screw/ 1	1 - Semi-hermetic double screw/ 1	1 - Semi-hermetic double screw/ 1
Refrigerant			R134A	R134A	R134A
Refrigerant charge		kg	please check	please check	please check
Diameter of refrigerant pipe (outdoor)	Liquid-gas	inches	1 1/8-2 1/8	1 1/8-2 1/8	1 1/8-2 1/8
Capacity control		%	25-100	25-100	25-100
Exchanger type			Plates	Plates	Plates
Water flow	Cooling (Min/Nom/Max)	m3/h	14.5-23.2-50.5	18.8-30.1-65.4	23.1-37.0-80.4
Water pipe diameter		inches	1/2	1/2	1/2
Minimum system water volume		m3	0.49	0.63	0.78
Condensation temperature		°C	30 to 60	30 to 60	30 to 60
Water production temperatures	Cooling - Standard	°C	5 to 15	5 to 15	5 to 15
	Cooling - Low option	°C	-5 to 5	-5 to 5	-5 to 5
	Cooling - High option	°C	15 to 25	15 to 25	15 to 25
Electrical power			3N ~400V 50 Hz	3N ~400V 50 Hz	3N ~400V 50 Hz
Consumption	Cooling (nominal)	kW	32.0	41.8	52.4
Current (maximum-start-up)		A	72.7-179	92.7-240	116-240
Dimensions (H x W x D)		mm	1,681x806x1,271	1,681x806x1,271	1,681x806x1,271
Weight		kg	765	835	900

Options and accessories:

See page 214.

Options and accessories

Samurai L options

	RCME-(60-90)AH2	RCME-(120-140)AH2	RHME-(60-90)AH2	RHME-(120-140)AH2	RCME-WH1	RCME-CLH1
Heat exchanger protection grilles	•	•	•	•		
Panels in the bottom of the unit	•	•	•	•		
Low noise level version	•	•	•	•	•	•
Super low noise level version	•	•	•	•	•	•
EXTRA super low noise level version	•	•	•	•		
Corrosion protection in heat exchangers	•	•	•	•		
W duct for power cables	•		•			
WO duct for power cables	•		•			
Duct for power cables					•	•
Wooden base	•		•		Standard	Standard
Wooden box					•	•
Wooden shoe	•		•			
Differential pressure flow switch	•	•	•	•	•	•
Discharge valve	•	•	•	•	•	Standard
Dual safety valve	•	•	•	•	•	•
Suction safety valve					•	•
Suction valve	•	•			•	•
Partial heat recovery	•	•	•	•		
Operation with low water output temperature (from 5°C to 0°C)	•	•	•	•	•	•
Operation with low water output temperature (-1°C to -5°C)	•	•	•	•	•	•
Operation with low water output temperature (from -6°C to -10°C)	•	•	•	•	•	•
Common water manifold		•		•		
Small single pump kit	•	•	•	•		
Large single pump kit	•	•	•	•		
Small double pump kit	•	•	•	•		
Large double pump kit	•	•	•	•		
Stainless steel water pipes	•	•	•	•	•	•
Water pressure connections	•	•	•	•	•	•
Safety cover on the bottom of the control cabinet	•	•	•	•		
Operation with setpoint control on condensation side					•	
Extended working range of the water output temperature	•	•	•	•	•	•
Magnetothermic switches	•	•	•	•	•	•
Energy meter	•	•	•	•	•	•
Anti-freeze element in evaporator	•	•	•	•	•	•

Unit options

Cooling circuit options

Hydraulic options

Control options

Samurai L Accessories

Name	Code
6" Water filter	CHL-WST-05
Modbus Interface	CHL-MBS-02
BACnet Interface	CHL-BAC-01
Anti-vibration spring system for CLH1 units	CHL-AVS-04
Common water manifold for two WH1 or CLH1 modules	CHL-CWP-05 For WH1: order two sets per module; for CLH1: order one set per module
Common water manifold for three WH1 or CLH1 modules	CHL-CWP-06 For WH1: order two sets per module; for CLH1: order one set per module
Anti-vibration spring system for WH1 units	CHL-AVS-05
Energy meter (200A)	CHL-PMM-04
Energy meter (400A)	CHL-PMM-05
Energy meter (1000A)	CHL-PMM-06
Common water manifold L-R for AH2 units up to 90 HP	CHL-CWP-07
Common water manifold -M- for AH2 units up to 90 HP	CHL-CWP-08
Anti-vibration spring system for 60 and 70 HP AH2 units	CHL-AVS-06
Anti-vibration spring system for 80 and 90 HP AH2 units	CHL-AVS-07
Anti-vibration spring system for 120 and 140 HP AH2 units	CHL-AVS-08
Certificate of origin	CO



Modbus Interface
CHL-MBS-02



BACnet Interface
CHL-BAC-01

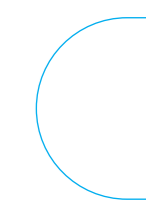

Technical tables additional notes

Yutaki air source heat pumps

The nominal heating and cooling capacities are based on Standard EN 14511:

- Cooling: water input temperature 12°C, output temperature 7°C and outside temperature 35°C DB.
- Heating: water input temperature 30°C, output at 35°C and outside temperature 7°C DB, 6°C WB.
- Pipe length: 7.5 metres; Height of pipes: 0 metres.

The heating capacity and performance are shown with integrated values (with defrost correction factor included).

The acoustic data are based on the following conditions:

- Outdoor ambient temperature (DB/WB): 7/6 °C.
- Water input/output temperature: 30/35 °C.
- Unit distance from measuring point: 1 metre from the front surface of the unit and 1.5 metres above ground level.

The acoustic pressure level has been measured in an anechoic chamber, meaning reflected sound must be taken into account when installing the unit.

The acoustic power level has been measured in a reverberant room in accordance with Standard EN12102. The environmental conditions used are those specified in Standard EN14511 for performance testing.

The SCOP heating seasonal performance values are calculated in accordance with ERP Directive 2009/125/CE, and more specifically with Standard 813/2013 (LOT 1) according to UNE EN 14825.

The seasonal performance value in domestic hot water production is calculated in compliance with ERP Directive 2009/125/CE, and more specifically with Regulation 814/2013 (LOT2) according to Standard UNE EN 16147.

All energy efficiency documents and the energy label (LOT 1 AND LOT 2) can be downloaded from the website: <https://www.hitachi-hvac.co.uk/apps>

Domestic 1x1 range units

(cooling power < 12kW)

The nominal heating and cooling capacity is the combined capacity of HITACHI's standard Split system, and is based on Standard ISO 5151:

- Cooling: indoor temperature 27°C DB, 19°C WB, outside temperature 35°C DB.
- Heating: indoor temperature 20°C DB, outside temperature 7°C DB, 6°C WB.
- Pipe length: 5 metres; Height of pipes: 0 metres.

The acoustic pressure level in indoor units is based on the following conditions:

- Wall-mounted units: 0.8 metres below the height centre of the indoor unit and 1 metre from discharge grille.
- Console units: half the height of the unit and 1 metre from the discharge grille
- Ducts: 0.8 metres below the height centre of the indoor unit and 1.5 metres from the discharge grille.
- Cassette: 0.8 metres below the height centre of the indoor unit and 1.5 metres from the discharge grille.

This data has been measured in an anechoic chamber and takes into account the reflected sound of the location.

The acoustic pressure level in outdoor units is based on the following conditions:

- 1 metre from the front surface of the unit and 1 metre above ground level

The SEER/SCOP seasonal cooling and heating values are calculated in compliance with Directive ERP 2009/125/CE, and more specifically with Standard 206/2012 (LOT 10), according to UNE EN 14825.

All energy efficiency documents and the energy label (LOT 10) can be downloaded from the website: <https://www.hitachi-hvac.co.uk/apps>

Commercial 1x1 range and VRF Systems units

(cooling capacity > 12kW)

The nominal cooling and heating capacity is the combined capacity of the outdoor unit and the indoor units, and is based on Standard EN14511, under the following operating conditions:

- Cooling: indoor temperature 27°C DB, 19°C WB, outside temperature 35°C DB.
- Heating: indoor temperature 20°C DB, outside temperature 7°C DB, 6°C WB.
- Pipe length: 7.5 metres; Height of pipes: 0 metres.

The acoustic pressure level in indoor units is based on the following conditions:

- Wall-mounted units: 1 m below the unit and 1.5 m from the discharge grille.
- Console units: 1 m above ground level and 1 m from the front of the unit.
- Ducts: 1.5 m below the unit (without a ceiling below it) with the suction duct at 1 m and the discharge duct at 2 m.
- Cassette: 1.5 m below the unit
- Ceiling: 1 m below the unit and 1 m from the discharge grille.

The acoustic pressure level has been measured in an anechoic chamber, meaning reflected sound must be taken into account when installing the unit.

The acoustic pressure level in outdoor units is based on the following conditions:

- The measurement point is 1.5 metres above the ground and 1 m from the front surface of the unit.
- Units operating at their rated voltage.

The acoustic pressure level has been measured in an anechoic chamber, meaning reflected sound must be taken into account when installing the unit.

The acoustic power level has been measured in a reverberant room in accordance with Standard EN12102. The environmental conditions used are those specified in Standard EN14511 for performance testing.

The SEER/SCOP seasonal cooling and heating performance values are calculated in compliance with ERP Directive 2009/125/CE, and more specifically with Standard 2281/2016 (LOT 21), in accordance with Standard UNE EN 14825 and calculated with RCI-FSN4 model cassette units.

All the energy efficiency documents (LOT 21) can be downloaded from the website: <https://www.hitachi-hvac.co.uk/apps>
The energy label (LOT 10) can be downloaded from the website: <https://www.hitachi-hvac.co.uk/apps>

Indoor units

The nominal cooling and heating capacity is the combined capacity of the outdoor unit and the indoor units, and is based on Standard EN14511, under the following operating conditions:

- Cooling: indoor temperature 27°C DB, 19°C WB, outside temperature 35°C DB.
- Heating: indoor temperature 20°C DB, outside temperature 7°C DB, 6°C WB.
- Pipe length: 7.5 metres; Height of pipes: 0 metres.

The indoor units have different cooling and heating capacity in the VRF IXV and VRF Set Free systems.

In the case of the VRF IXV system, the nominal capacity shown in the following tables is for combinations of an indoor unit with an outdoor unit of the VRF IXV Premium or IXV Comfort series [RAS-(2-6)HVNP1(E), RAS-(4-12)H(V)NP(1)(E), RAS-(3-6)H(V)NC1(E) and RAS-(4-12)H(V)NC(1)(E)], provided such a combination is permitted.

The acoustic pressure level has been measured in an anechoic chamber under the following conditions:

- Indoor units RCI (M), RCD: 1.5 m below the unit.
- RPI indoor units (M): 1.5 metres below the unit (no ceiling below the unit), with the suction duct at 1 m and the discharge duct at 2 m.
- RPC and RPK indoor units: 1 m below the unit, 1 m from the discharge grille.
- RPF indoor units (I): 1 m above ground level, 1 m from the front of the unit.

The acoustic power level has been measured in a reverberant room in accordance with Standard EN12102. The environmental conditions used are those specified in Standard EN14511 for performance testing.

Dx-Kit

The nominal cooling and heating capacity is the combined capacity of the outdoor unit and the associated DX interface (EXV-0E2), and is based on Standard EN14511, under the following operating conditions:

- Cooling: indoor temperature 27°C DB, 19°C WB, outside temperature 35°C DB.
- Heating: indoor temperature 20°C DB, outside temperature 7°C DB, 6°C WB.
- Pipe length: 7.5 metres; Height of pipes: 0 metres.

The acoustic pressure level in outdoor units is based on the following conditions:

- The measurement point is 1.5 metres above the ground and 1 m from the front surface of the unit.
- Units operating at their rated voltage.

The acoustic pressure level has been measured in an anechoic chamber, meaning reflected sound must be taken into account when installing the unit.

The acoustic power level has been measured in a reverberant room in accordance with Standard EN12102. The environmental conditions used are those specified in Standard EN14511 for performance testing.

The outdoor units of the "RAS-XH (V)NP(1)E" series have been designed for specific applications that require the combination of a Series 2 DX Interface and are not Eurovent certified. They may vary depending on each particular application.

Hydraulic module

The heating and cooling nominal capacities are based on Standard EN 14511 and show the data in integrated values (with defrost correction factor included).

The acoustic data are based on the following conditions:

- Outdoor ambient temperature (DB/WB): 7/6 °C.
- Water input/output temperature: 30/35 °C.
- Unit distance from the measuring point: 1 metre from the front of the unit and 1.5 metres above ground level.

The measurements were made in a reverberant room in accordance with Standard EN12102. The environmental conditions used are those specified in Standard EN14511 for performance testing.

Units in the air renewal range – KPI and KPI Active

The sound pressure level has been measured in an anechoic chamber, with the measuring point located 1.5 m below the unit, without a ceiling over it and using a soundproof duct. Suction duct at 1 m and discharge duct at 2 m.

Reflected sound should be considered when installing the unit. The sound pressure level measured in the installation may be higher than specified.

In the case of KPI-X4E units with direct expansion battery, the nominal cooling and heating capacity is the combined capacity of the outdoor and indoor units of the system and is based on Standard EN14511, under the following operating conditions:

- Cooling: indoor temperature 27°C DB, 19°C WB, outside temperature 35°C DB.
- Heating: indoor temperature 20°C DB, outside temperature 7°C DB, 6°C WB.
- Pipe length: 7.5 metres; Height of pipes: 0 metres.
- Active KPI unit operating at its nominal air flow.

Chiller range units

The capacity data are based on European standard EN14511 under the following conditions:

In cooling mode:

- Cold water input/output temperature: 12/7 °C.
- Condenser input air temperature: 35 °C.

In heating mode:

- Hot water input/output temperature 40/45°C.
- Condenser input air temperature: 6°C (WB).

All sound pressure level data are measured at a height of 1.5 m, at 1 m from the front panel of the unit.

The low water temperature option requires brine (ethylene glycol or propylene glycol-type antifreeze mixture).

For more information, please see the technical manuals for each range at <https://www.hitachi-hvac.co.uk/resources>

1. DEFINITIONS

In these conditions;

- (1) "HITACHI" means: Johnson Controls Hitachi Air Conditioning Europe SAS, UK Branch, (registration no. FC030594), with registered office located at Whitebrook Park, Lower Cookham Road, Maidenhead, SL6 8YA, United Kingdom.
- (2) "Buyer" means: the person, firm or company specified overleaf, to whom HITACHI's Quotation, Sales Confirmation or Invoice is addressed.
- (3) "Goods" means: the goods to be sold by HITACHI to the Buyer under the Contract.
- (4) "Contract" means: the contract of sale hereby formed between HITACHI and Buyer.

2. CONSTRUCTION OF CONTRACT

- (1) The terms of the Contract shall consist of the particulars overleaf and these conditions. Any term overleaf which is at variance with these conditions shall prevail over these conditions, which shall be construed accordingly, except with regard to price in respect of which provisions of sub clause 6 (2) shall prevail.
- (2) No other terms (whether contained in any document issued by the Buyer or in any written or oral communication between the parties) shall apply to the Contract nor shall these conditions or the particulars overleaf be modified without HITACHI's written agreement.

3. QUOTATIONS AND ORDERS

- (1) Unless accepted before lapse or withdrawal, or renewed in writing by HITACHI, quotations shall lapse automatically after 60 days, but may be withdrawn earlier by HITACHI.
- (2) Quotations are for information only and are not firm offers. There shall be no binding contract until HITACHI has accepted the buyer's order by dispatching HITACHI's official sales confirmation.

4. DELIVERY

- (1) The scope of supply by HITACHI under the Contract shall be strictly limited to those specified overleaf, and no other goods or services are included.
- (2) HITACHI will use all reasonable endeavors to deliver the Goods on or before the delivery date specified overleaf, however, HITACHI does not undertake, guarantee or warrant that delivery will be made on the delivery date specified.
- (3) Any such delivery date specified shall be extended by any period or periods during which the manufacture or delivery of the Goods or other work by HITACHI in connection with this Contract is prevented, hindered, delayed or rendered uneconomic by reason of a Force Majeure Event (as defined in clause 18 below).
- (4) The Buyer acknowledges that, in the case of semiconductor products, optoelectronic products and other electronic components, due to the advanced technology in the Goods and the specialist nature of the manufacturing process, manufacture of the Goods by HITACHI's normal means may result in a loss of yield. In the event of such a loss of yield HITACHI shall notify the Buyer and shall use its reasonable endeavors to supply the

Goods in accordance with this Contract.

If due to a Force Majeure Event or due to loss of yield HITACHI has insufficient stocks to meet all its commitments HITACHI may apportion stock between its customers at its sole discretion.

- (5) If any delivery time specified overleaf is so extended by more than 90 days then the Buyer shall be entitled to give written notice to HITACHI requiring the Goods to be delivered within 30 days of the date of such notice, failing which the Buyer shall have the right to give further written notice determining the Contract forthwith.
- (6) HITACHI shall be entitled to deliver the Goods in one or more instalments. Where delivery is effected by instalment each instalment shall be treated as a separate contract. Delay in delivery or other default of any instalment shall not relieve the Buyer of its obligations to accept and pay for the remaining deliveries.
- (7) In the case of the Buyer residing in the United Kingdom, unless otherwise stated, HITACHI will at its own expense deliver to the Buyer's premises. In the case of exports, unless otherwise stated, delivery will be FOB (Incoterms 2010) at a UK port designated by HITACHI.
- (8) The delivery by HITACHI of a greater or lesser quantity of the Goods than the quantity provided for in the Contract, the delivery of other goods not provided for in the Contract, or the delivery of the Goods only some of which are defective, shall not entitle the Buyer to reject all of the Goods delivered. In order that HITACHI can comply with its carrier's conditions any claim in respect of error in quantity or type of Goods or in respect of damage to the Goods in transit must be made in writing to HITACHI and the carrier notified in both cases within 3 days of receipt of the Goods. Failure to make such claim shall constitute unqualified acceptance of the Goods and waiver by the Buyer of all claims relating to error in quantity or type of goods delivered or relating to the condition of Goods delivered. Similarly, if any Goods invoiced by HITACHI are not delivered, in order that HITACHI can claim against its carriers where appropriate the Buyer must notify HITACHI within 10 days of the date of invoice, failing which the Buyer will be liable to pay for the Goods in full. Where liability for error in quantity, or type of Goods or in respect of damage to the Goods in transit is accepted by HITACHI, HITACHI's only obligation shall be, at its option, to make good any shortage or non-delivery and/or as appropriate to replace or repair any Goods found to be damaged or defective and/or to refund the cost of such Goods to the Buyer.
- (9) If the Buyer refuses or fails to take delivery of Goods tendered in accordance with this Contract HITACHI shall be entitled to terminate this Contract with immediate effect, to dispose of the Goods as HITACHI may determine, and to recover from the Buyer any loss and expenses incurred as a result of such refusal or failure.
- (10) Section 32 (2) of the Sale of Goods Act 1979 shall not apply. HITACHI shall not be required to give the Buyer the notice specified in Section 32 (3) of the Act.

- (11) Unless expressly agreed in writing by HITACHI, all Goods shall be packed in accordance with HITACHI's standard practice. The Buyer shall meet the costs of any special packaging requested by the Buyer or any packaging rendered necessary by delivery by any means other than HITACHI's normal means of delivery.

5. RISK AND TITLE

- (1) NOTWITHSTANDING DELIVERY, PROPERTY IN THE GOODS SUPPLIED SHALL REMAIN WITH HITACHI UNTIL THOSE GOODS HAVE BEEN PAID FOR IN FULL (TOGETHER WITH ANY ACCRUED INTEREST).
- (a) RISK IN THE GOODS SHALL PASS ON DELIVERY. The Buyer shall store the Goods separately or in such a way as will show clearly that they are HITACHI's property and the Buyer will ensure that they are kept in good condition and insured against loss or damage for HITACHI's benefit. Until property in the Goods passes to the Buyer, the Buyer shall hold the proceeds of any claim on the insurance policy on trust for HITACHI and shall immediately account to HITACHI with the proceeds.
- (b) THE BUYER SHALL HOLD THE GOODS IN A FIDUCIARY CAPACITY AND AS BAILEE FOR HITACHI WHO MAY WITHOUT PREJUDICE TO ANY OTHER OF ITS RIGHTS REPOSSESS THE GOODS TO WHICH IT HAS RETAINED TITLE AS AFORESAID and thereafter re-sell the same and for this purpose the Buyer hereby grants an irrevocable right and license to HITACHI's servants and agents to enter upon all or any of its premises with or without vehicles during normal business hours for the purpose of inspecting and/or repossessing Goods to which it has retained title. This right shall continue to subsist notwithstanding the termination of this Contract for any reason and is without prejudice to any accrued rights of HITACHI hereunder or otherwise.
- (c) The Buyer agrees to provide HITACHI, within twenty-four hours of a written request made by HITACHI, a certificate stating (i) the Goods that the Buyer still holds and that the Buyer has its custody, directly or through a third party depository; and (ii) the names and contact information (address, telephone number and email) of any subsequent purchasers of the Goods, and the amounts owed by such purchasers to the Buyer.
- (d) HITACHI may at any time detach or separate any of its Goods which may have been incorporated in or attached to goods belonging to the Buyer or any third party.
- (2) HITACHI reserve the right, exercisable at its option by notice in writing to the Buyer, to waive the provisions of sub clause 5 (1) above at any time before payment has been made for the Goods supplied by the Buyer and to declare that property in the Goods shall have passed to the Buyer.
- (3) Notwithstanding that property in the Goods shall not have passed to the Buyer, HITACHI, without prejudice to any other of its rights, may sue for the price of the Goods supplied in the event that payment is not made on the due date.
- (4) Any return of Goods wholly or partly by the Buyer to HITACHI, except in the case of defective Goods pursuant to Clause 8, shall be subject to HITACHI's prior written consent and

Buyers payment to HITACHI of interest charges for the period from the date of HITACHI's shipment of such Goods to the Buyer to the date of HITACHI's receipt of such Goods. Freight, insurance and any other expenses incurred in connection with such return shall be borne by the Buyer.

6. PRICES

- (1) Unless otherwise stated overleaf, prices of the Goods shall be exclusive of VAT, export duty and foreign import duty and any other import or other taxes, which shall where applicable be paid by the Buyer.
- (2) Prices stated in any quotation or in HITACHI's Sales Confirmation are provisional only and subject to adjustment to take account of increases in HITACHI's costs and overheads, including, without limitation, costs of carriage and labor costs. The Contract price shall be HITACHI's price ruling at the date of dispatch. All quotations/sales confirmations and invoices are issued subject to the unconditional reservation of HITACHI's right to adjust prices in respect of the following:-
 - (a) Changes in the prevailing exchange rate between the currency in which the price is to be paid and the Japanese Yen; (b) Changes in the current EU import duty.

7. PAYMENT

- (1) If HITACHI has granted the Buyer credit facilities, the payment of the price must be made in full within 30 days of the date of invoice, unless otherwise specified overleaf or agreed to by HITACHI. Any extension of credit allowed for the Buyer may be changed or withdrawn at any time. Where no credit has been granted, payment must be made in full in cash prior to delivery. Payment shall be made in full direct to HITACHI in the currency invoiced. The Buyer shall not be entitled to exercise any right of set-off, counterclaim, abatement or analogous deduction against payment due to HITACHI. Time of payment is of the essence of a Contract. HITACHI reserves the right to suspend the provision of Goods to the Buyer where any amounts are overdue under any Contract with the Buyer until all such amounts have been paid.
- (2) HITACHI is authorized to invoice daily interest (penalties for late payment) on any amount unpaid at the rate stipulated by the Late Payment of Commercial Debt Regulations 2013 (as amended) from the due date until the date of actual payment of all unpaid amounts (including interest) (after, as before, judgment). Costs in excess may also be claimed if justified.
- (3) If, in the opinion of HITACHI, the creditworthiness of the Buyer shall have deteriorated prior to the delivery, HITACHI may require full or partial payment of the price prior to delivery or the provision of security for payment in full (including any accrued interest) by the Buyer in a form acceptable to HITACHI notwithstanding any credit terms that may have been agreed between HITACHI and the Buyer.
- (4) Notwithstanding any purported contrary appropriation by the Buyer, all payments made by the Buyer to HITACHI shall be appropriated first to Goods which have been

resold by the Buyer and then to Goods which remain in the possession or under the control of the Buyer.

- (5) HITACHI is entitled to offset any amount owing to it from the Buyer against any amount owed to the Buyer by HITACHI.

8. WARRANTIES

- (1) If the Goods are defective on delivery, and the defects arise from faulty materials or workmanship and are not caused by fair wear and tear, abnormal or unsuitable conditions of storage, transportation or use, or the combination of the Goods with any goods not supplied by HITACHI or any act, neglect or default of the Buyer or any third party and HITACHI is given written notice of the defects promptly upon discovery by the Buyer and at any rate within six months (or such other period of time as may specifically be agreed to by HITACHI for certain types of Goods) after delivery then, unless otherwise specified overleaf, HITACHI's sole obligation shall be (at its option) to repair or replace the defective item or allow the Buyer the price thereof and to pay or reimburse the reasonable carriage charges for the return of defective Goods to the Buyer and for delivery of the replaced or repaired item.
- (2) Unless otherwise agreed between HITACHI and the Buyer, if any of the Goods are not HITACHI made, the provisions of sub clause 8 (1) above shall apply only to the extent covered by any warranty made by the supplier of such Goods to HITACHI.
- (3) The Buyer shall retain the Goods at its premises until instructed by HITACHI to return them. Goods alleged to be defective shall be subject to inspection and testing by HITACHI at its own or (if HITACHI so chooses) at the Buyer's premises and the Buyer shall allow HITACHI adequate facilities at the Buyer's premises to investigate the complaint.
- (4) Subject to sub clause 8 (1) above, HITACHI gives no representation or warranty and there is not incorporated in the Contract any condition whether express or implied, statutory or otherwise, as to the Goods other than the statutory warranty of title, and any such representations, conditions or warranties are hereby expressly excluded and HITACHI shall be under no liability to the Buyer for any loss, damage or injury (including special, direct, indirect or consequential loss and loss of profit) resulting from defective materials, faulty workmanship or otherwise howsoever arising and whether or not caused by the negligence of HITACHI, its employees or agents SAVE THAT HITACHI shall accept liability for death or personal injury caused by the negligence of HITACHI.
- (5) Subject to sub clause 8 (1), the warranty for RAC products shall be 36 months after delivery of the Goods or from the date of invoice ,whichever is earlier.
- (6) Subject to sub clause 8 (1) , the warranty for Utopia and Set Free Systems shall be 60 months from delivery of Goods or from the date of invoice, whichever is earlier.
- (7) For further information on UK warranty terms, please visit the following website www.hitachi-hvac.co.uk/apps



Johnson Controls Hitachi Air Conditioning Europe S.A.S

Whitebrook Park,
Lower Cookham Road,
Maidenhead, UK
SL6 8YA

www.hitachi-hvac.co.uk

HITACHI. CERTIFIED QUALITY



This brochure has been carefully prepared by us to the best of our knowledge and exclusively taking into account the information available to us. We assume no responsibility for the completeness and accuracy of this or for the reliability and usability of the information given in this Brochure illustrated products or services for a particular purpose or field of application does not guarantee and / or express a tacit guarantee. Changes to technical data and / or the equipment can be provided at any time without notice. We don't accept any liability for direct or indirect damages, of whatever kind, resulting from the use or interpretation of this brochure. The Copyrights of all texts or images are owned by Johnson Controls Hitachi Air Conditioning Europe SAS (JCH), unless otherwise stated in this brochure. This brochure is not a binding offer from JCH.