

# 6. Dimensions

## 6.1 Indoor Unit

### 6.1.1 CS-TZ20WKEW CS-TZ25WKEW CS-TZ35WKEW CS-TZ42WKEW CS-TZ50WKEW CS-RZ20WKEW CS-RZ25WKEW CS-RZ35WKEW CS-RZ50WKEW

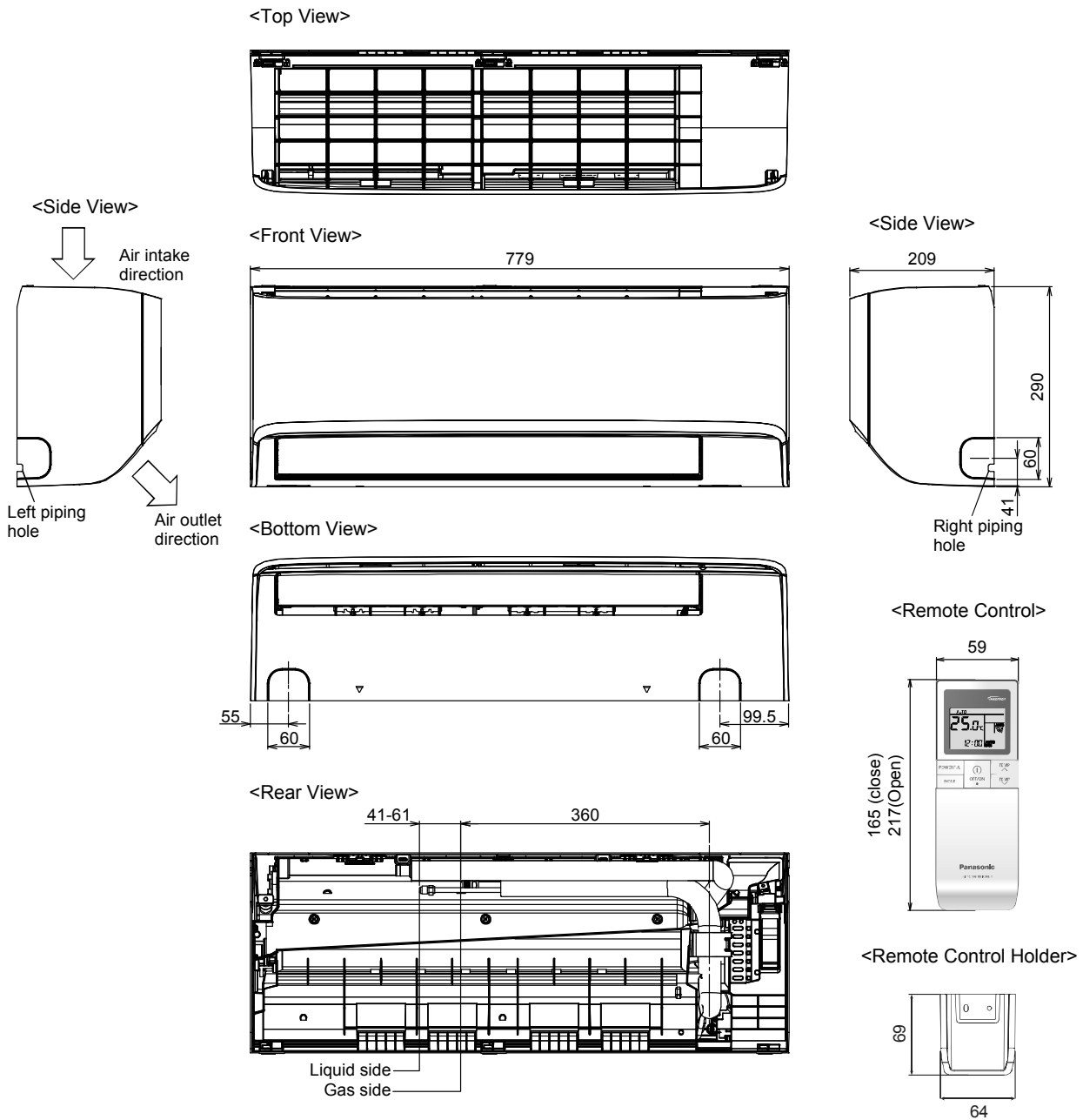

Relative position between the indoor unit and the installation plate <Front View>

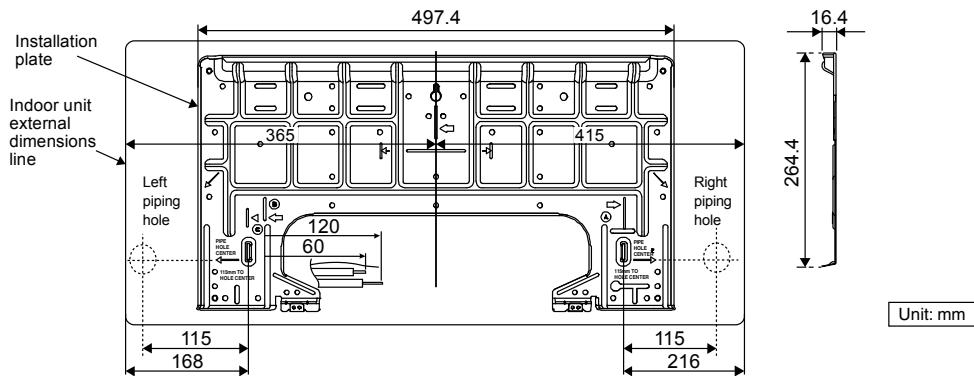

## 6.1.2 CS-TZ60WKEW CS-TZ71WKEW

<Top View>

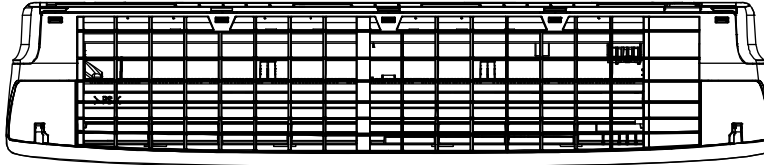

<Side View>

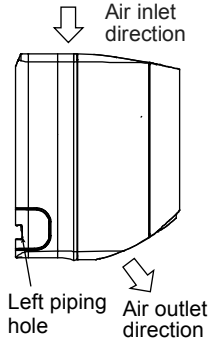

<Front View>

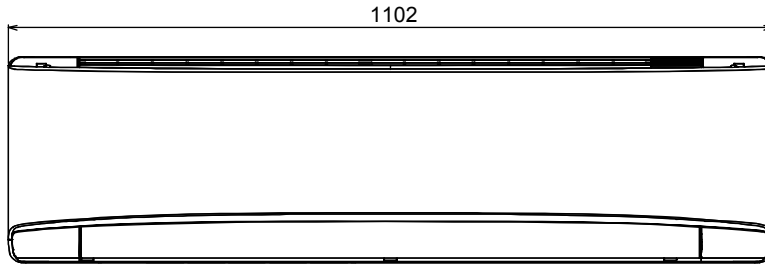

<Side View>

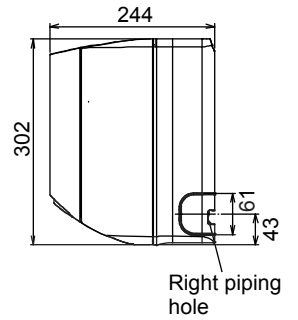

<Bottom View>

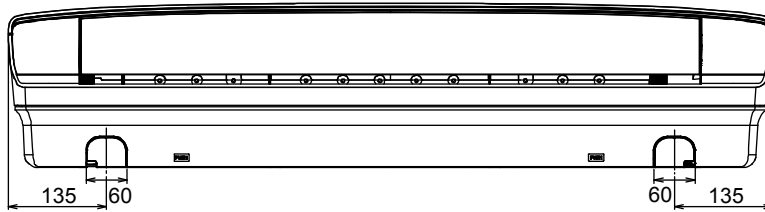

<Remote Control>

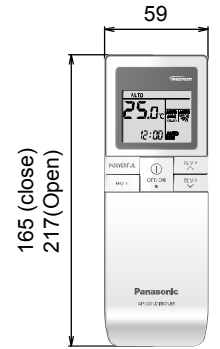

<Rear View>

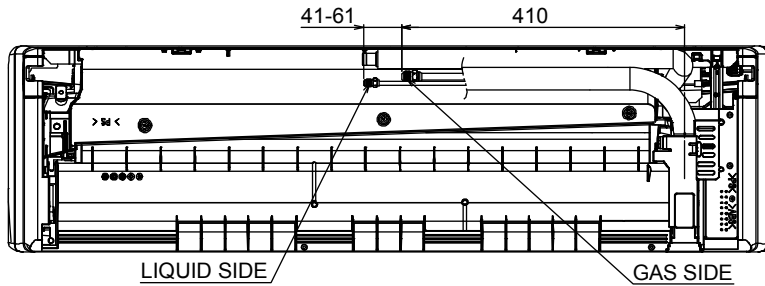

<Remote Control Holder>

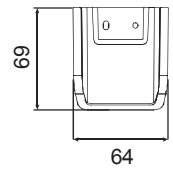

Relative position between the indoor unit and the installation plate <Front View>

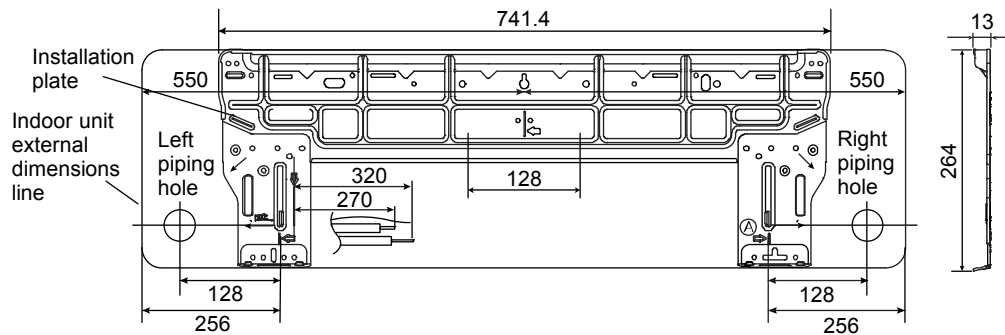

Unit: mm

## 6.2 Outdoor Unit

### 6.2.1 CU-TZ20WKE CU-TZ25WKE CU-TZ35WKE CU-TZ42WKE CU-RZ20WKE CU-RZ25WKE CU-RZ35WKE

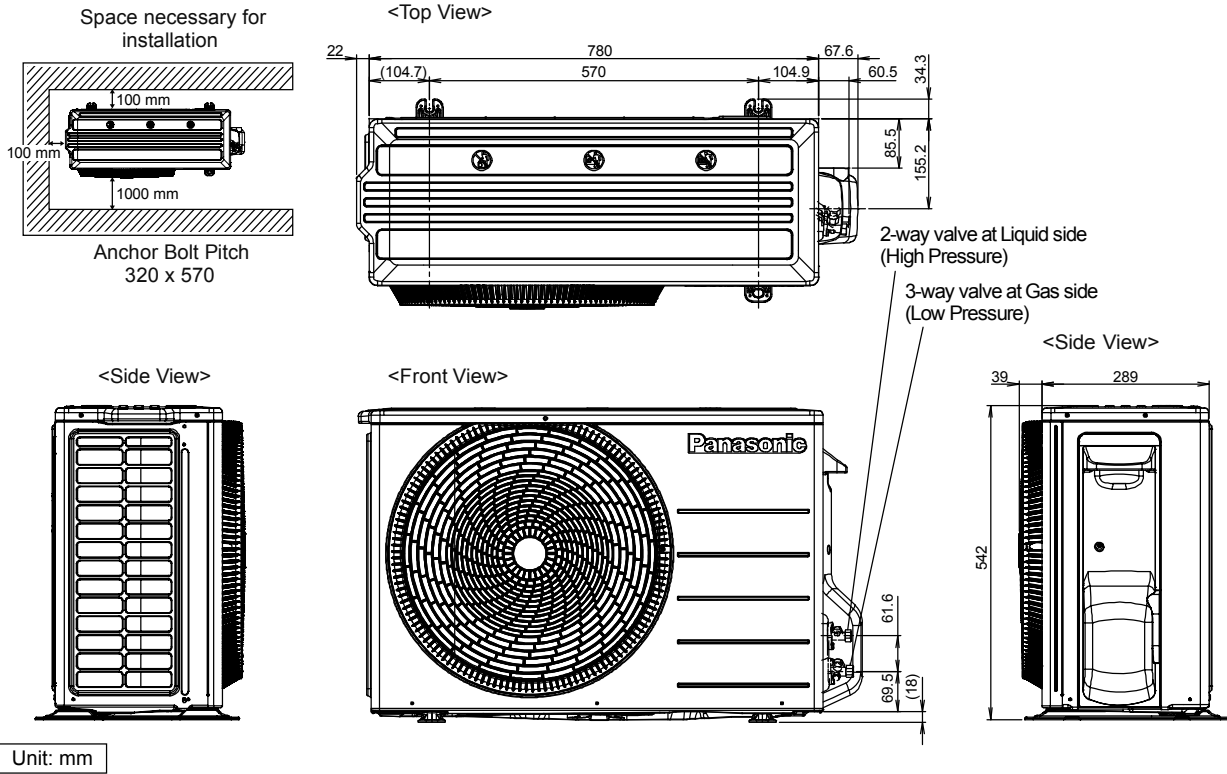

### 6.2.2 CU-TZ50WKE CU-TZ60WKE CU-RZ50WKE

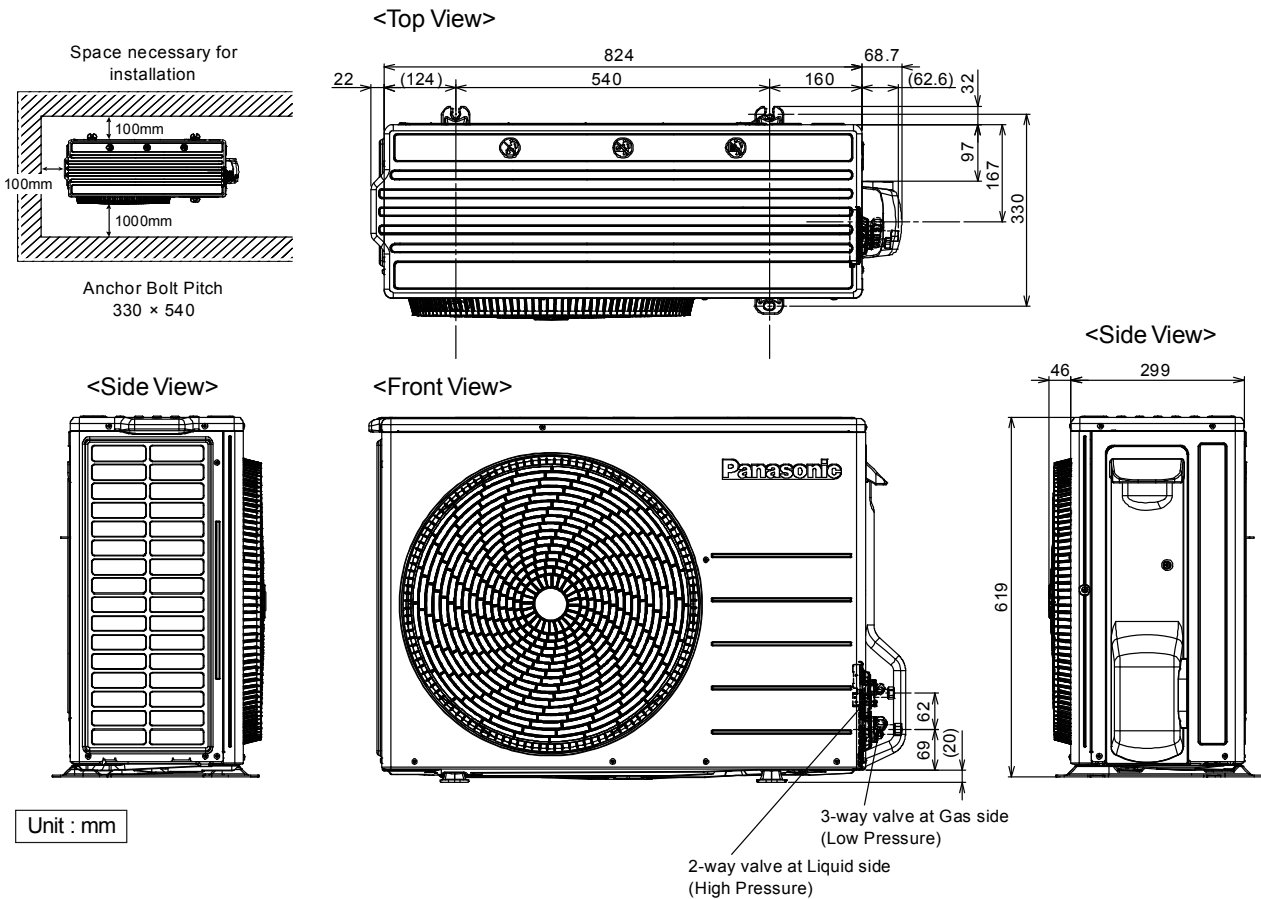

### 6.2.3 CU-TZ71WKE

