



**MITSUBISHI  
ELECTRIC**

REFRIGERANT  
R32/R410A

## FLOOR TYPE AIR CONDITIONERS

MFZ-KT25VG

MFZ-KT35VG

MFZ-KT50VG

MFZ-KT60VG

**Note:**

These models can be connected to the multi units, except for KT60.

INSTALLATION MANUAL

English

INSTALLATIONSANLEITUNG

Deutsch

NOTICE D'INSTALLATION

Français

INSTALLATIEHANDLEIDING

Nederlands

MANUAL DE INSTALACIÓN

Español

MANUALE PER L'INSTALLAZIONE

Italiano

ΕΓΧΕΙΡΙΔΙΟ ΕΓΚΑΤΑΣΤΑΣΗΣ

Ελληνικά

MANUAL DE INSTALAÇÃO

Português

INSTALLATIONSHÅNDBOG

Dansk

INSTALLATIONSANVISNING

Svenska

РЪКОВОДСТВО ЗА МОНТАЖ

Български

INSTRUKCJA MONTAŻU

Polski

INSTALLASJONSHÅNDBOK

Norsk

ASENNUSOPAS

Suomi

INSTALAČNÍ PŘÍRUČKA

Čeština

NÁVOD NA INŠTALÁCIU

Slovenčina

TELEPÍTÉSI KÉZIKÖNYV

Magyar

NAMESTITVENI PRIROČNIK

Slovenščina

MANUAL DE INSTALARE

Română

PAIGALDUSJUHEND

Eesti

MONTĀŽAS ROKASGRĀMATA

Latviski

MONTAVIMO VADOVAS

Lietuviškai

PRIRUČNIK ZA POSTAVLJANJE

Hrvatski

UPUTSTVO ZA UGRADNJU

Srpski

## CONTENTS





1. BEFORE INSTALLATION.....	1	<b>Model names are indicated in 1-3.</b> This installation manual describes only for the indoor unit. Refer to the MXZ type manual for outdoor unit set up.
2. INDOOR UNIT INSTALLATION.....	4	
3. FLARE CONNECTION, PIPE CONNECTION.....	8	
4. TEST RUN.....	8	
5. PUMPING DOWN.....	9	

## Required Tools for Installation

Phillips screwdriver	Flare tool for R32, R410A
Level	Gauge manifold for R32, R410A
Scale	Vacuum pump for R32, R410A
Utility knife or scissors	Charge hose for R32, R410A
75 mm hole saw	Pipe cutter with reamer
Torque wrench	Water bottle
Wrench (or spanner)	0.9 to 1.0 L water

## 1. BEFORE INSTALLATION

## MEANINGS OF SYMBOLS DISPLAYED ON INDOOR UNIT AND/OR OUTDOOR UNIT

	<b>WARNING</b> (Risk of fire)	This unit uses a flammable refrigerant. If refrigerant leaks and comes in contact with fire or heating part, it will create harmful gas and there is risk of fire.
		Read the OPERATING INSTRUCTIONS carefully before operation.
		Service personnel are required to carefully read the OPERATING INSTRUCTIONS and INSTALLATION MANUAL before operation.
		Further information is available in the OPERATING INSTRUCTIONS, INSTALLATION MANUAL, and the like.

## 1-1. THE FOLLOWING SHOULD ALWAYS BE OBSERVED FOR SAFETY

- Be sure to read "THE FOLLOWING SHOULD ALWAYS BE OBSERVED FOR SAFETY" before installing the air conditioner.
- Be sure to observe the warnings and cautions specified here as they include important items related to safety.
- After reading this manual, be sure to keep it together with the OPERATING INSTRUCTIONS for future reference.

**WARNING** (Could lead to death, serious injury, etc.)

- **Do not install the unit by yourself (user).**  
Incomplete installation could cause fire or electric shock, injury due to the unit falling, or leakage of water. Consult the dealer from whom you purchased the unit or a qualified installer.
- **Perform the installation securely referring to the installation manual.**  
Incomplete installation could cause fire or electric shock, injury due to the unit falling, or leakage of water.
- **When installing the unit, use appropriate protective equipment and tools for safety.**  
Failure to do so could cause injury.
- **Install the unit securely in a place which can bear the weight of the unit.**  
If the installation location cannot bear the weight of the unit, the unit could fall causing injury.
- **Electrical work should be performed by a qualified, experienced electrician, according to the installation manual. Be sure to use an exclusive circuit. Do not connect other electrical appliances to the circuit.**  
If the capacity of the power circuit is insufficient or there is incomplete electrical work, it could result in a fire or an electric shock.
- **Earth the unit correctly.**  
Do not connect the earth to a gas pipe, water pipe, lightning rod or telephone earth. Defective earthing could cause electric shock.
- **Do not damage the wires by applying excessive pressure with parts or screws.**  
Damaged wires could cause fire or electric shock.
- **Be sure to cut off the main power in case of setting up the indoor P.C. board or wiring works.**  
Failure to do so could cause electric shock.
- **Use the specified wires to connect the indoor and outdoor units securely and attach the wires firmly to the terminal block connecting sections so the stress of the wires is not applied to the sections. Do not extend the wires, or use intermediate connection.**  
Incomplete connecting and securing could cause fire.
- **Do not install the unit in a place where flammable gas may leak.**  
If gas leaks and accumulates in the area around the unit, it could cause an explosion.
- **Do not use intermediate connection of the power cord or the extension cord and do not connect many devices to one AC outlet.**  
It could cause a fire or an electric shock due to defective contact, defective insulation, exceeding the permissible current, etc.
- **Be sure to use the parts provided or specified parts for the installation work.**  
The use of defective parts could cause an injury or leakage of water due to a fire, an electric shock, the unit falling, etc.
- **When plugging the power supply plug into the outlet, make sure that there is no dust, clogging, or loose parts in both the outlet and the plug. Make sure that the power supply plug is pushed completely into the outlet.**  
If there is dust, clogging, or loose parts on the power supply plug or the outlet, it could cause electric shock or fire. If loose parts are found on the power supply plug, replace it.
- **Attach the electrical cover to the indoor unit and the service panel to the outdoor unit securely.**  
If the electrical cover of the indoor unit and/or the service panel of the outdoor unit are not attached securely, it could result in a fire or an electric shock due to dust, water, etc.
- **When installing, relocating, or servicing the unit, make sure that no substance other than the specified refrigerant (R32/R410A) enters the refrigerant circuit.**  
Any presence of foreign substance such as air can cause abnormal pressure rise and may result in explosion or injury. The use of any refrigerant other than that specified for the system will cause mechanical failure, system malfunction, or unit breakdown. In the worst case, this could lead to a serious impediment to securing product safety.
- **Do not alter the unit.**  
It may cause fire, electric shock, injury or water leakage.
- **Do not discharge the refrigerant into the atmosphere. If refrigerant leaks during installation, ventilate the room. Check that the refrigerant does not leak after installation has been completed.**  
If refrigerant leaks and comes in contact with fire or heating part of such a fan heater, kerosene heater, or cooking stove, it will create harmful gas. Provide ventilation in accordance with EN378-1.
- **Use appropriate tools and piping materials for installation.**  
The pressure of R32/R410A is 1.6 times more than R22. Not using appropriate tools or materials and incomplete installation could cause the pipes to burst or injury.
- **When pumping down the refrigerant, stop the compressor before disconnecting the refrigerant pipes.**  
If the refrigerant pipes are disconnected while the compressor is running and the stop valve is open, air could be drawn in and the pressure in the refrigeration cycle could become abnormally high. This could cause the pipes to burst or injury.
- **When installing the unit, securely connect the refrigerant pipes before starting the compressor.**  
If the compressor is started before the refrigerant pipes are connected and when the stop valve is open, air could be drawn in and the pressure in the refrigeration cycle could become abnormally high. This could cause the pipes to burst or injury.
- **Fasten a flare nut with a torque wrench as specified in this manual.**  
If fastened too tight, a flare nut may break after a long period and cause refrigerant leakage.
- **The unit shall be installed in accordance with national wiring regulations.**
- **When using a gas burner or other flame-producing equipment, completely remove all of the refrigerant from the air conditioner and ensure that the area is well-ventilated.**  
If the refrigerant leaks and comes in contact in fire or heating part, it will create harmful gas and there is risk of fire.
- **Do not use means to accelerate the defrosting process or to clean, other than those recommended by the manufacturer.**
- **The appliance shall be stored in a room without continuously operating ignition sources (for example: open flames, an operating gas appliance or an operating electric heater).**
- **Do not pierce or burn.**
- **Be aware that refrigerants may not contain an odour.**
- **Pipe-work shall be protected from physical damage.**
- **The installation of pipe-work shall be kept to a minimum.**
- **Compliance with national gas regulations shall be observed.**
- **Keep any required ventilation openings clear of obstruction.**
- **Keep gas-burning appliances, electric heaters, and other fire sources (ignition sources) away from the location where installation, repair, and other air conditioner work will be performed.**
- **The appliance shall be stored in a well-ventilated area where the room size corresponds to the room area as specified for operation.**
- **Do not turn the breaker OFF except the case of burning smell, or when performing maintenance or inspection.**  
The power cannot be supplied to the refrigerant sensor mounted in the indoor unit, and the sensor cannot detect the refrigerant leakage. This may cause a fire.

**⚠ CAUTION** (Could lead to serious injury in particular environments when operated incorrectly.)

- **Install an earth leakage breaker depending on the installation place.**  
If an earth leakage breaker is not installed, it could cause electric shock.
- **Perform the drainage/piping work securely according to the installation manual.**  
If there is defect in the drainage/piping work, water could drop from the unit, soaking and damaging household goods.
- **Do not touch the air inlet or the aluminum fins of the outdoor unit.**  
This could cause injury.
- **Do not install the outdoor unit where small animals may live.**  
If small animals enter and touch the electric parts inside the unit, it could cause a malfunction, smoke emission, or fire. Also, advise user to keep the area around the unit clean.
- **Do not operate the air conditioner during interior construction and finishing work, or while waxing the floor.**  
Before operating the air conditioner, ventilate the room well after such work is performed. Otherwise, it may cause volatile elements to adhere inside the air conditioner, resulting in water leakage or scattering of dew.
- **Do not install the unit in a place where smoke, gas, or chemicals may fill.**  
The refrigerant sensor mounted in the indoor unit may react to it, and display an error of refrigerant leakage.
- **Be careful of the fan rotation when the breaker is ON.**  
When the refrigerant sensor detects the refrigerant leakage, the fan starts rotating automatically. This may cause injury.

## 1-2. SELECTING THE INSTALLATION LOCATION

This manual only describes the installation of indoor unit.  
When installing the outdoor unit, refer to the installation manual of outdoor unit.

### INDOOR UNIT

**⚠ ⚠ WARNING**

**This unit should be installed in rooms which exceed the floor space specified in outdoor unit installation manual.**

- Refer to outdoor unit installation manual.
- Where airflow is not blocked.
- Where cool (or warm) air spreads over the entire room.
- Rigid wall without vibration.
- Where it is not exposed to direct sunshine. Do not expose to direct sunshine also during the period following unpacking to before use.
- Where easily drained.
- At a distance 1 m or more away from your TV and radio. Operation of the air conditioner may interfere with radio or TV reception. An amplifier may be required for the affected device.
- In a place as far away as possible from fluorescent and incandescent lights. In order to make the infrared remote control operate the air conditioner normally. The heat from the lights may cause deformation or the ultraviolet may cause deterioration.
- Where the air filter can be removed and replaced easily.
- Where it is away from the other heat or steam source.
- Do not install the unit in the environment where any gas equipment for propane, butane or methane, sprays such as bug killer, equipment which generates smoke, paint etc., and chemicals are used, or in the place where sulfur-based gas is generated.
- The refrigerant sensor mounted in the indoor unit may react to them, and display an error of refrigerant leakage. This may cause the unit not to operate.

### REMOTE CONTROLLER

- Where it is easy to operate and easily visible.
- Where children cannot touch it.
- Select a position about 1.2 m above the floor and check that signals from the remote controller are surely received by the indoor unit from that position ('beep' or 'beep beep' receiving tone sounds). After that, attach remote controller holder to a pillar or wall and install wireless remote controller.

**Note:**

In rooms where inverter type fluorescent lamps are used, the signal from the wireless remote controller may not be received.

**Note:**

Avoid the following places for installation where air conditioner trouble is liable to occur.

- Where flammable gas could leak.
- Where there is much machine oil.
- Where oil is splashed or where the area is filled with oily smoke (such as cooking areas and factories, in which the properties of plastic could be changed and damaged).
- Salty places such as the seaside.
- Where sulfide gas is generated such as hot spring, sewage, waste water.
- Where there is high-frequency or wireless equipment.
- Where there is emission of high levels of VOCs, including phthalate compounds, formaldehyde, etc., which may cause chemical cracking.
- The appliance shall be stored so as to prevent mechanical damage from occurring.

If connect to the outdoor unit that uses R32 refrigerant, install in a room with a floor area of Amin or more, corresponding to refrigerant M (factory-charged refrigerant + locally add refrigerant). For refrigerant quantity and additional refrigerant charge, refer to the outdoor unit.

M [kg]	Amin [m²]	
1.00	No requirements	
1.10		
1.20		
1.30		
1.40		
1.50		
1.60		
1.70		
1.80		
1.84		3.63
1.90		3.75
2.00		3.95
2.10		4.15
2.20	4.34	
2.30	4.54	
2.40	4.74	

Refer to the installation manual of outdoor unit for refrigerant charge.

### 1-3. SPECIFICATIONS

Model	Power supply *1		Wire specifications *2	Pipe size (thickness *3, *4, *5, *6)		Insulation thickness *7,*8
	Rated Voltage	Frequency	Indoor/outdoor connecting wire	Gas	Liquid	
MFZ-KT25VG	230 V	50 Hz	4-core 2.0 mm <sup>2</sup>	ø9.52 mm (0.8 mm)	ø6.35 mm (0.8 mm)	14 mm
MFZ-KT35VG				ø12.7 mm (0.8 mm)		
MFZ-KT50VG						
MFZ-KT60VG						

\*1 Connect to the power switch which has a gap of 3 mm or more when open to interrupt the source power phase. (When the power switch is shut off, it must interrupt all phases.)  
 \*2 Use wires in conformity with design 60245 IEC 57.  
 \*3 Never use pipes with thickness less than specified. The pressure resistance will be insufficient.

\*4 Use a copper pipe or a copper-alloy seamless pipe.  
 \*5 Be careful not to crush or bend the pipe during pipe bending.  
 \*6 Refrigerant pipe bending radius must be 100 mm or more.  
 \*7 Insulation material : Heat resisting foam plastic 0.045 specific gravity

\*8 Be sure to use the insulation of specified thickness. Excessive thickness may cause incorrect installation of the indoor unit and insufficient thickness may cause dew dripage.

### 1-4. INSTALLATION DIAGRAM

When installing outdoor units, refer to the installation of outdoor units.

The piping specification table does not provide a minimum line set length. However, indoor units with connected piping length less than 3 m could produce intermittent noise during normal system operation in very quiet environments. Please be aware of this important information when installing and locating the indoor unit within the conditioned space.

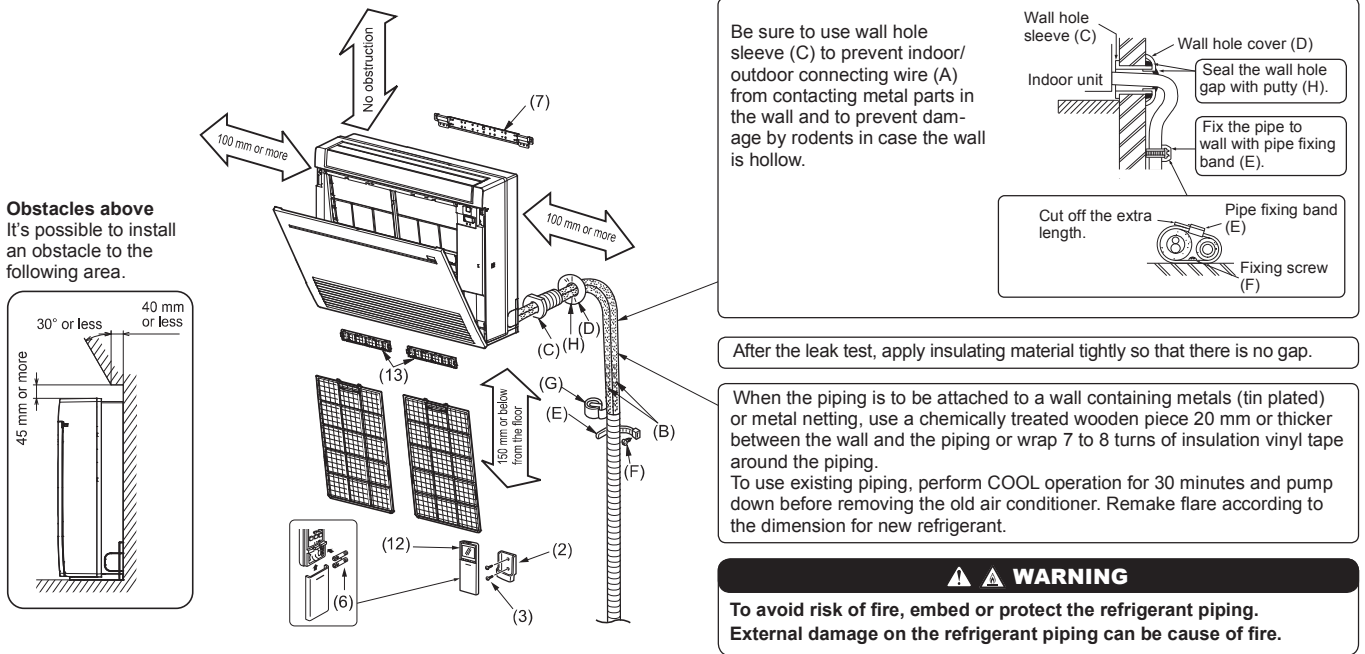

Units should be installed by licensed contractor according to local code requirements.

#### ACCESSORIES

Check the following parts before installation.

(1) Drain hose*	1
(2) Remote controller holder	1
(3) Fixing screw for (2) 3.5 × 16 mm (Black)	2
(4) Pipe cover	1
(5) Band	2
(6) Battery (AAA) for (12)	2
(7) Indoor unit mounting bracket	1
(8) Fixing screw for (7) 4 × 25 mm	5
(9) Wood screw for indoor unit fixation	4
(10) Washer of (9)	4
(11) Felt tape (For left or left-rear piping)	1
(12) Wireless remote controller	1
(13) Air cleaning filter	2
(14) Joint pipe (KT60 only)	1
(15) Pipe cover for joint pipe (KT60 only)	1
(16) Breaker tag	1
(17) Breaker notice	1

\* Note:  
 The Drain hose is connected to the unit.

#### PARTS TO BE PROVIDED AT YOUR SITE

(A) Indoor/outdoor unit connecting wire*	1
(B) Extension pipe	1
(C) Wall hole sleeve	1
(D) Wall hole cover	1
(E) Pipe fixing band	2 to 5
(F) Fixing screw for (E) 4 × 20 mm	2 to 5
(G) Piping tape	1
(H) Putty	1
(J) Drain hose (or soft PVC hose, 15 mm inner dia. or hard PVC pipe VP16)	1 or 2
(K) Refrigeration oil	1
(L) Power supply cord*	1

\* Note:  
 Place indoor/outdoor unit connecting wire (A) and power supply cord (L) at least 1 m away from the TV antenna wire.

## 2. INDOOR UNIT INSTALLATION

### 2-1. FIXING OF INDOOR UNIT MOUNTING BRACKET

- Do not install the indoor unit at a place higher than 150 mm.
- Find a structural material (such as a stud) in the wall and fix bracket (7) horizontally with fixing screws (8).
- To prevent bracket (7) from vibrating, be sure to install the fixing screws in the holes indicated in the illustration. For added support, fixing screws may also be installed in other holes.

### 2-2. HOLE DRILLING

- 1) Determine the wall hole position.
- 2) Drill a dia. 65 mm hole (dia. 75 ~ 80 mm for KT50/60). The outdoor side should be 5 to 7 mm lower than the indoor side.
- 3) Insert wall hole sleeve (C).

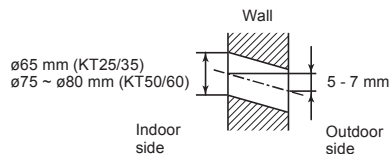

#### HOLE POSITIONS

**FOR REAR OR LEFT-REAR PIPING**  
(The following figure is a front view of the indoor unit installation location.)

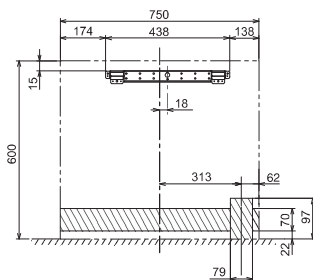

**FOR RIGHT DOWNWARD OR LEFT DOWNWARD PIPING**  
(The following figure is a view of the bottom of the indoor unit from above.)

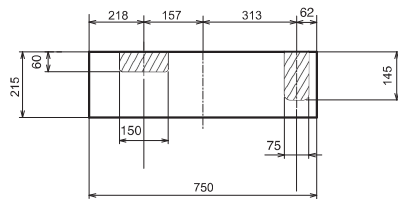

**FOR LEFT PIPING    FOR RIGHT PIPING**

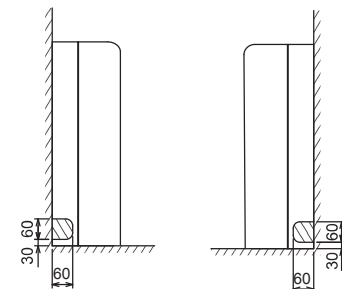

EN

### 2-3. INDOOR UNIT PREPARATION

Remove the front panel of the indoor unit.

- 1) Push down the tab on the both sides of the unit to open the front panel.
- 2) Pull the front panel toward you to remove it.
- 3) Remove the 2 screws.
- 4) Open the rear horizontal vane.
- 5) Push the 2 locations on the top of the panel, and then pull the upper part of the panel toward you.
- 6) Remove the panel while lifting it up (slightly).

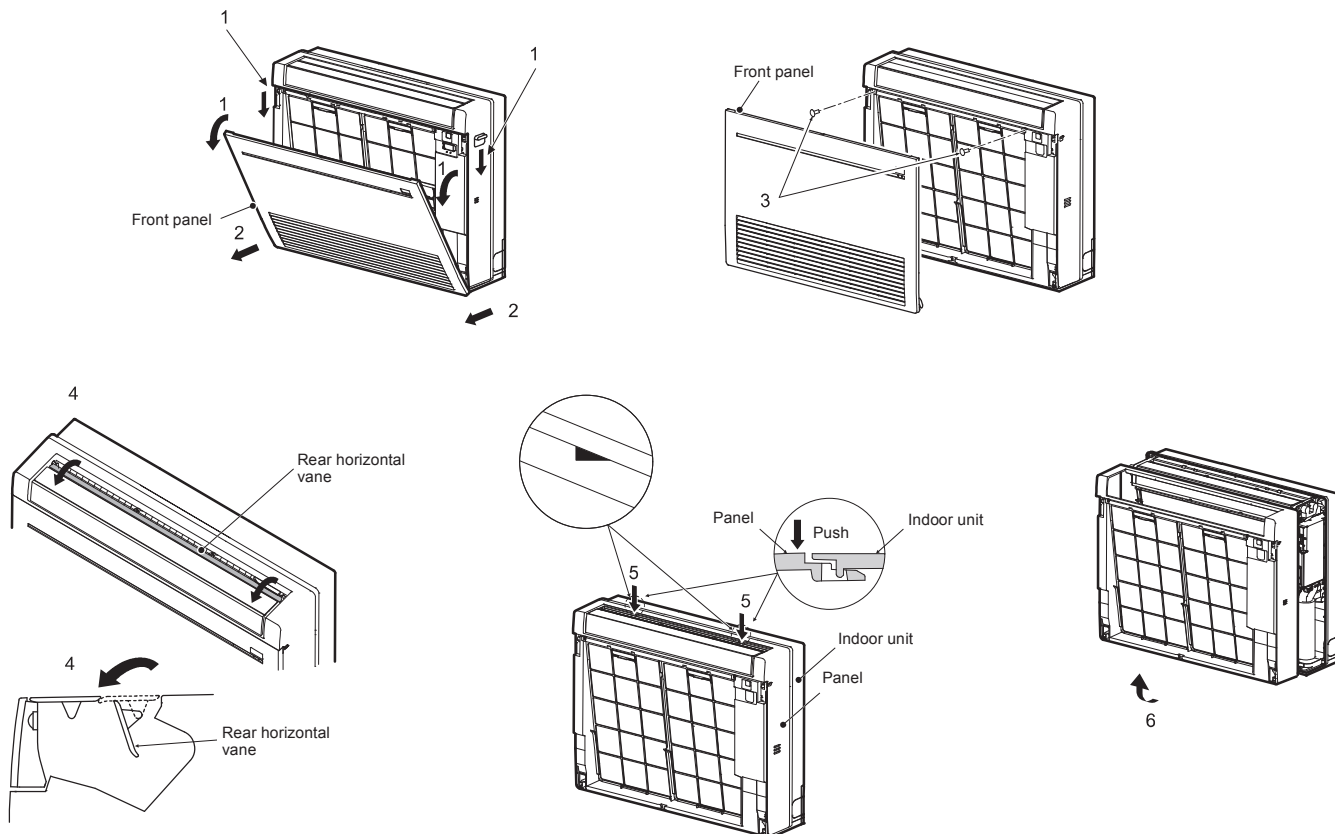

## 2-4. INDOOR UNIT INSTALLATION

### 2-4-1. INSTALLING THE INDOOR UNIT ON THE FLOOR

- 1) Place the indoor unit on the flat floor.
- 2) Fix the indoor unit at 4 points with the included wood screws (9) and washers (10). Tighten the screws securely.

### 2-4-2. MOUNTING THE INDOOR UNIT ON THE WALL

- 1) Hook the top of the indoor unit on the indoor unit mounting bracket (7).
- 2) Fix the indoor unit at 4 points with the included wood screws (9) and washers (10). Tighten the screws securely.

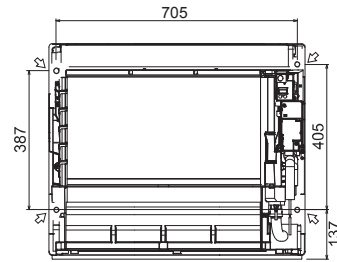

### 2-4-3. EMBEDDING THE INDOOR UNIT IN A WALL

- 1) Make a hole in the wall.
- 2) Using reinforcement material, adjust the depth.
- 3) Remove 6 screws that fix the base to the unit. Remove the base from the unit.
- 4) Fix the indoor unit at 4 points with the included wood screws (9) and washers (10). Tighten the screws securely.

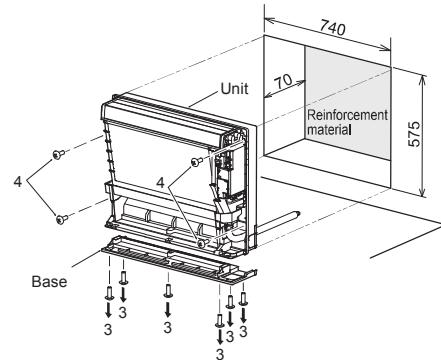

## 2-5. CONNECTING WIRES FOR INDOOR UNIT

- 1) Remove VA clamp.
- 2) Pass indoor/outdoor unit connecting wire (A) from the back of the indoor unit and process the end of the wire.
- 3) Loosen terminal screw, and connect first the earth wire, then indoor/outdoor unit connecting wire (A) to the terminal block. Be careful not to make mis-wiring. Fix the wire to the terminal block securely so that no part of its core is appeared, and no external force is conveyed to the connecting section of the terminal block.
- 4) Firmly tighten the terminal screws to prevent them from loosening. After tightening, pull the wires lightly to confirm that they do not move.
- 5) Secure indoor/outdoor unit connecting wire (A) and the earth wire with the VA clamp. Never fail to hook the left claw of the VA clamp. Attach the VA clamp securely.

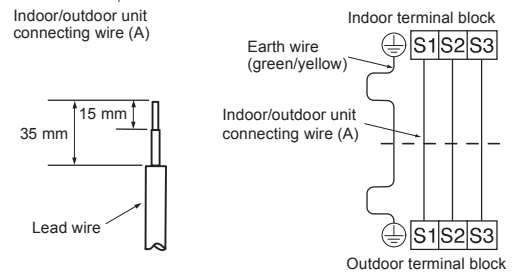
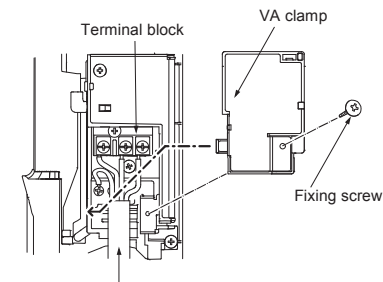

- Make earth wire a little longer than others. (More than 45 mm)
- For future servicing, give extra length to the connecting wires.
- Do not fold the excess wire, or cram it into small space. Take caution not to damage the wires.
- Be sure to attach each screw to its correspondent terminal when securing the cord and/or the wire to the terminal block.

### ⚠ WARNING

When installing the unit, securely connect the refrigerant pipes before starting the compressor.

## 2-6. PIPE FORMING AND INSTALLATION

**Note:** Refer to 3. FLARE CONNECTION, PIPE CONNECTION.

### Pipe Forming

- Route the drain hose diagonally below the connecting pipes.
- Make sure that the drain hose is not routed upward and that there are no waves in the hose.
- Do not pull the hose when applying the tape.
- Route the piping so that it does not project past the rear of the indoor unit. (Refer to the figure to the right.)

### Connecting Pipe Installation

- Install the connecting pipes so that the piping can move slightly to the front, back, left, and right.
- When the cover is removed, be sure to cover the pipes so that no piping is exposed to the room after installing the piping.
- Fill the gap after installing the piping.

- Be sure to insulate the connecting pipes so that they do not contact the panel.
- Be careful not to crush the connecting pipes when bending them.

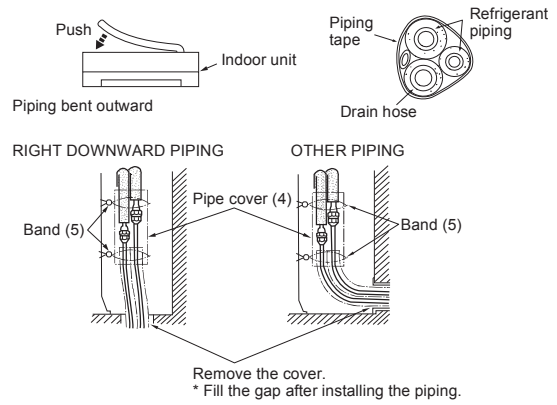

### For MFZ-KT60

- Be sure to use the joint pipe (14), otherwise the extension pipe of  $\phi 15.88$  cannot be fixed.
- Flare the joint pipe (14) to  $\phi 12.7$ , and attach the pipe cover (15).

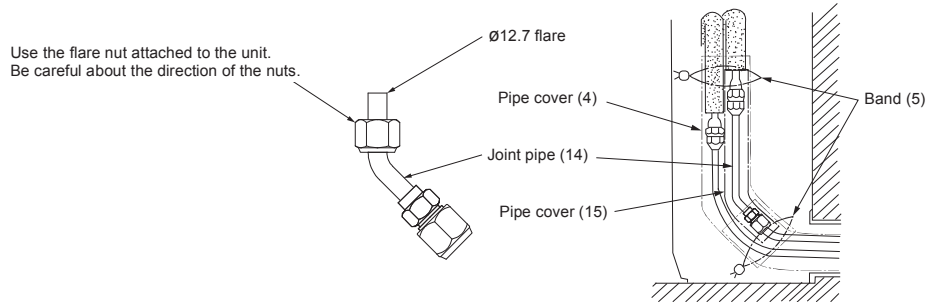

### FOR LEFT OR LEFT-REAR PIPING

Bundle the connecting pipes and drain hose together, and then wrap them in felt tape (11).

Cut and use the lower side panels on the left and right sides of the indoor unit as shown below. Smooth the cut edges of the side panels so that they will not damage the insulation coating.

- For left or right piping
- Installing flush against a wall with molding

Wrap the felt tape (11) tightly around the pipes and hose starting near where the pipes and hose are routed from the indoor unit. (The overlap width of the felt tape (11) should not be more than 1/2 of the tape width.)

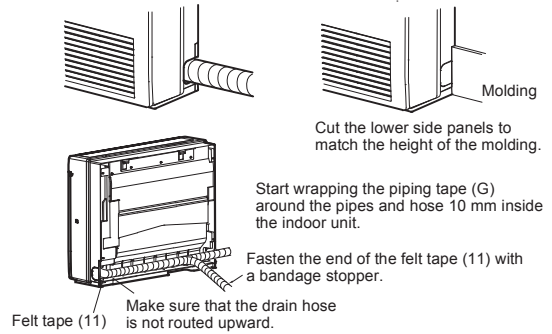

## 2-7. DRAIN PIPING

- If the extension drain hose has to pass through a room, be sure to wrap it with commercially sold insulation.
- The drain hose should point downward for easy drain flow. (Fig. 1)
- If the drain hose provided with the indoor unit is too short, connect it with drain hose (J) that should be provided at your site. (Fig. 2)
- When connecting the drain hose to the hard vinyl chloride pipe, be sure to insert it securely into the pipe. (Fig. 3)

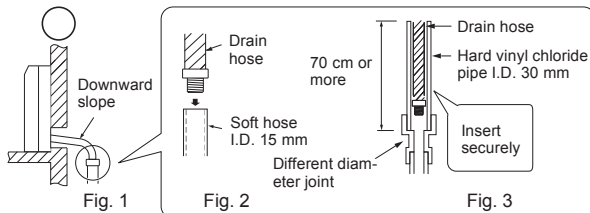

Do not make drain piping as shown below.

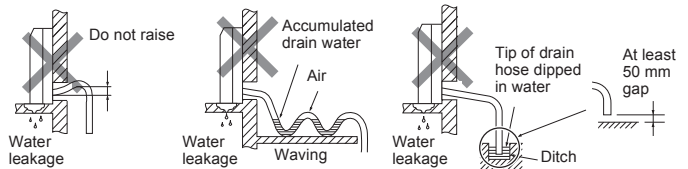

### The Drain hose is removed at installation.

- When routing the drain piping, make sure that the drain hose (1) is routed as shown. (Fig. 4)
- Insert the drain hose all the way to the base of the drain pan (end connection). (Fig. 5) Make sure that the catch of the drain hose is securely hooked onto the projection on the hose fitting of the drain pan.
- After connecting the drain hose, be sure to pull the hose to confirm that it is connected securely.

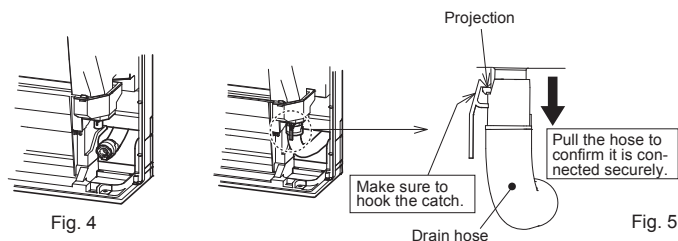

## 2-8. FRONT PANEL INSTALLATION

- 1) Open the rear horizontal vane.
- 2) Attach the panel. Make sure that the catches are engaged.
- 3) Fix the panel with screws.
- 4) Insert the bottom part of the front panel.
- 5) Push 3 places on the upper part of the front panel to close it.

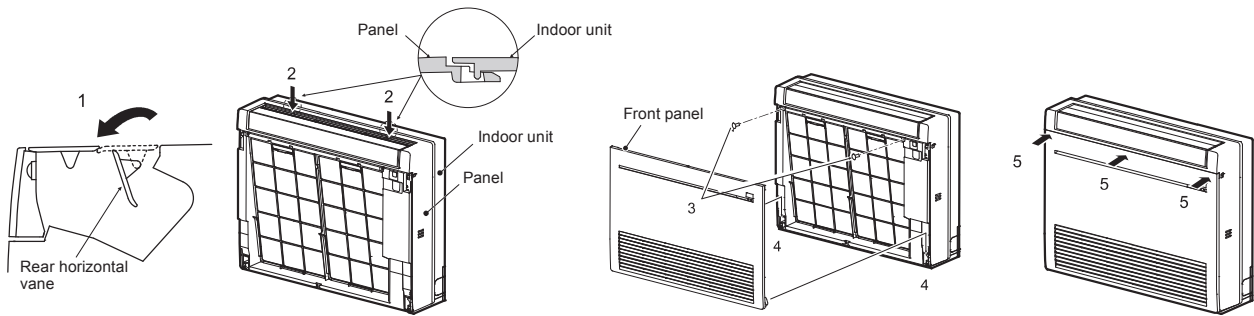

## 2-9. HOW TO ATTACH THE LABEL AND THE EXPLANATION

The breaker must be always ON except when performing maintenance or inspection. Hang the accompanying label (16) or (17) on the breaker, and explain it to customers. When turning the breaker OFF, the power is not supplied to the refrigerant sensor mounted in the indoor unit, and the refrigerant leakage cannot be detected.

Note: When the wiring is separate indoor unit/outdoor unit power supplies, hang the accompanying label (16) or (17) on the breaker of indoor unit side, and explain it to customers.

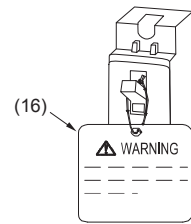

## 2-10. CONNECTING AN INTERFACE (option)/CONNECTOR CABLE (option) TO THE AIR CONDITIONER

- Connect an interface/connector cable to the indoor control P.C. board of an air conditioner with a connecting cable.
- Cutting or extending the connecting cable of the interface/connector cable results in defects in connecting. Do not bundle the connecting cable together with power supply cord, indoor/outdoor connecting wire, and/or earth wire. Keep as much distance as possible between the connecting cable and those wires.
- The thin part of the connecting cable should be stored and placed where customers cannot touch it.

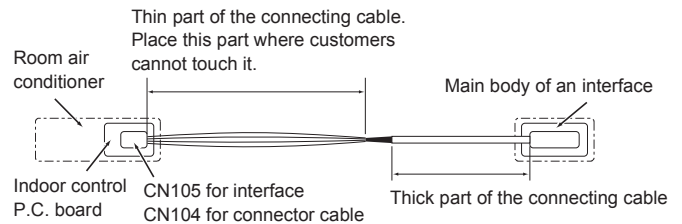

- 1) Remove the panel.
- 2) Open the cover of the indoor control P.C. board.
- 3) Join the connecting cable to CN105 and/or CN104 on the indoor control P.C. board.
- 4) Route the connecting cable through this point in the figure.
- 5) Attach the cable clamp provided with interface/connector cable to the thick part of the connecting cable with a screw 4×16 as shown in the figure.
- 6) Close the cover of the indoor control P.C. board. Be careful not to catch the thin part of the connecting cable in the cover. Reinstall the panel.

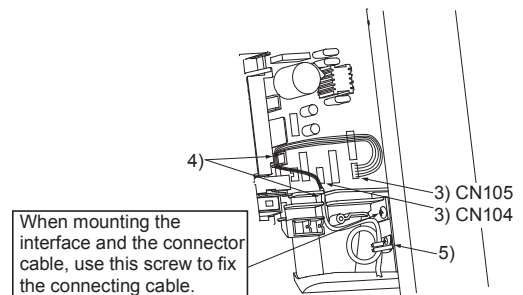

### **▲ WARNING**

Fix the connecting cable at the prescribed position securely.  
Incorrect installation may cause electric shock, fire, and/or malfunction.



### 3. FLARE CONNECTION, PIPE CONNECTION

#### 3-1. FLARING WORK

- 1) Cut the copper pipe correctly with pipe cutter. (Fig. 1, 2)
- 2) Completely remove all burrs from the cut cross section of pipe. (Fig. 3)
  - Put the end of the copper pipe to downward direction as you remove burrs in order to avoid to let burrs drop in the piping.
- 3) Remove flare nuts attached to indoor and outdoor units, then put them on pipe having completed burr removal. (Not possible to put them on after flaring work.)
- 4) Flaring work (Fig. 4, 5). Firmly hold copper pipe in the dimension shown in the table. Select A mm from the table according to the tool you use.
- 5) Check
  - Compare the flared work with Fig. 6.
  - If flare is noted to be defective, cut off the flared section and do flaring work again.

Pipe diameter (mm)	Nut (mm)	A (mm)			Tightening torque	
		Clutch type tool for R32, R410A	Clutch type tool for R22	Wing nut type tool for R22	N·m	kgf·cm
ø6.35 (1/4")	17	0 to 0.5	1.0 to 1.5	1.5 to 2.0	13.7 to 17.7	140 to 180
ø9.52 (3/8")	22				34.3 to 41.2	350 to 420
ø12.7 (1/2")	26			2.0 to 2.5	49.0 to 56.4	500 to 575
ø15.88 (5/8")	29			-	73.5 to 78.4	750 to 800

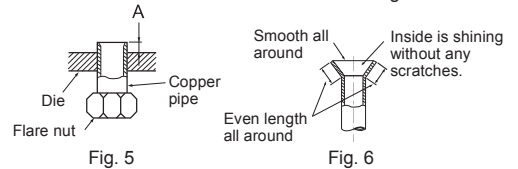
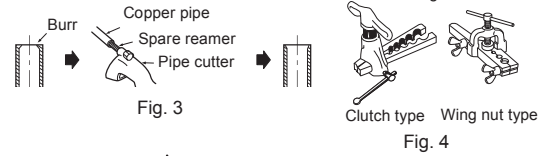
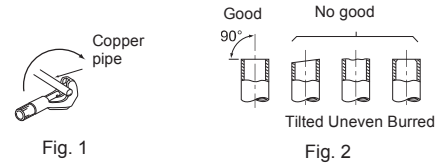

#### 3-2. PIPE CONNECTION

- Fasten flare nut with a torque wrench as specified in the table.
- When fastened too tight, flare nut may break after a long period and cause refrigerant leakage.
- Be sure to wrap insulation around the piping. Direct contact with the bare piping may result in burns or frostbite.

##### Indoor unit connection

- Connect both liquid and gas pipings to indoor unit.
- Apply a thin coat of refrigeration oil (K) on the flared ends of the pipes. Do not apply refrigeration oil on screw threads. Excessive tightening torque will result in damage on the screw.
- For connection, first align the center, then tighten the first 3 to 4 turns of flare nut.
- Use tightening torque table above as a guideline for indoor unit side union joint section, and tighten using two wrenches.

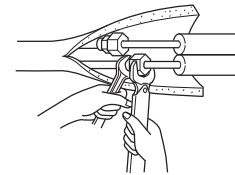

#### ⚠ WARNING

When installing the unit, securely connect the refrigerant pipes before starting the compressor.

#### ⚠ WARNING

Reusable mechanical connectors and flared joints are not allowed indoors. When connecting the refrigerant piping by brazing, rather than using flare connections, complete all brazing prior to connecting indoor unit to outdoor unit.

### 4. TEST RUN

#### 4-1. TEST RUN

Make sure the following is done.

- Panel is installed correctly.
  - Indoor and outdoor units are installed correctly, and power is supplied.
- 1) Press the E.O. SW once for COOL, and twice for HEAT operation. Test run will be performed for 30 minutes. If the left lamp of the operation indicator blinks every 0.5 seconds, inspect the indoor/outdoor unit connecting wire (A) for mis-wiring. After the test run, emergency mode (set temperature 24°C) will start.
  - 2) To stop operation, press the E.O. SW several times until all LED lamps turn off. Refer to operating instructions for details.

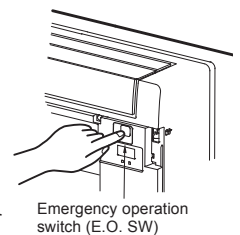

##### Checking the remote (infrared) signal reception

Press the ON/OFF button on the remote controller (12) and check that an electronic sound is heard from the indoor unit. Press the ON/OFF button again to turn the air conditioner off.

- Once the compressor stops, the restart preventive device operates so the compressor will not operate for 3 minutes to protect the air conditioner.

#### 4-2. AUTO RESTART FUNCTION

This product is equipped with an auto restart function. When the power supply is stopped during operation, such as during blackouts, the function automatically starts operation in the previous setting once the power supply is resumed. (Refer to the operating instructions for details.)

##### Caution:

- After test run or remote signal reception check, turn off the unit with the E.O. SW or the remote controller before turning off the power supply. Not doing so will cause the unit to start operation automatically when power supply is resumed.

##### To the user

- After installing the unit, make sure to explain the user about auto restart function.
- If auto restart function is unnecessary, it can be deactivated. Consult the service representative to deactivate the function. Refer to the service manual for details.

#### 4-3. EXPLANATION TO THE USER

- Using the OPERATING INSTRUCTIONS, explain to the user how to use the air conditioner (how to use the remote controller, how to remove the air filters, how to remove or put the remote controller in the remote controller holder, how to clean, precautions for operation, etc.)
- Recommend the user to read the OPERATING INSTRUCTIONS carefully.

## 5. PUMPING DOWN

Refer to the procedures indicated in the installation manual of the outdoor unit.

### **⚠ WARNING**

When pumping down the refrigerant, stop the compressor before disconnecting the refrigerant pipes. The compressor may burst if air etc. get into it.