

English

Read through the Installation Instructions before you proceed with the installation.
In particular, you will need to read under the “Safety Precautions” on page 2.

Contents

●Safety Precautions	2
●Specifications	2
Supplied accessories	3
●Dimensions (Part Names)	3
●Caution for Network Connection.....	3
●Installation Precautions	3
Installation Location.....	3
General Precautions on Wiring	3
●Mounting.....	3
Design Control Box	3
Mounting Position.....	3
How to Mount (Control Box).....	3
●Preparations for Wiring.....	4
Power Supply Wiring	4
Inter-Unit Control Wiring.....	4
Communication Adaptor Control Wiring ...	4
External I/O Wiring	4
LAN Cable	4
●Wiring	4
●Connecting to External Equipment.....	5
●Setting and Test Operation	5



Safety Precautions

Please Read Before Starting

This controller must be installed by the sales dealer or installer. These instructions are all you need for most installation sites and maintenance conditions. If you require help for a special problem, contact our sales/service outlet or your certified dealer for additional instructions.

WARNING

This symbol refers to a hazard or unsafe practice which can result in severe personal injury or death.

CAUTION

This symbol refers to a hazard or unsafe practice which can result in personal injury or product or property damage.

- We assume no responsibility for accidents or damages resulting from methods other than those described in the installation instructions or methods without using specified parts. Malfunctions that occurred due to the unauthorised installation methods are not covered by the product warranty.
- This controller shall be installed in accordance with National Wiring Regulations.
- After the installation is complete, perform test operation to confirm that no abnormality is present.
- Read the installation instructions of devices to be connected as well.
- When relocating or repairing this controller, provide the Installation Instructions to the servicing personnel.

WARNING

 **ELECTRICAL SHOCK CAN CAUSE SEVERE PERSONAL INJURY OR DEATH. ONLY A QUALIFIED, EXPERIENCED ELECTRICIAN SHOULD ATTEMPT TO WIRE THIS SYSTEM.**

- Highly dangerous electrical voltages are used in this system. Carefully refer to the wiring diagram and these instructions when wiring. Improper connections and inadequate grounding can cause **accidental injury or death**.
- This controller is strongly recommended to be installed with Earth Leakage Circuit Breaker (ELCB) or Residual Current Device (RCD). Otherwise, it may cause electrical shock and fire in case of equipment breakdown or insulation breakdown. Earth Leakage Circuit Breaker (ELCB) must be incorporated in the fixed wiring in accordance with the wiring regulations. The Earth Leakage Circuit Breaker (ELCB) must be an approved

- 10 A, having a contact separation by 3 mm in all poles.
- Provide a power outlet to be used exclusively for this controller.
- Turn off the circuit breaker of the controllers before installation.
- Do not supply power to the controller until all wiring is completed or reconnected and checked.
- Fix the power supply wiring securely with the clammer so that the power supply terminal board is free of tension (external force) when pulled. Loose connection of the terminal board may cause fire.
- To prevent possible hazards from insulation failure, the controller must be grounded. 
- Select an installation location which is rigid and strong enough to support or hold the controller, and select a location for easy maintenance.
- This product must not be modified or disassembled under any circumstances. Modified or disassembled controller may cause fire, electric shock or injury.
- Do not clean inside the controller by users. Engage authorized dealer or specialist for cleaning.
- Do not operate with wet hands.

CAUTION

- Ground yourself to discharge static electricity before performing any wiring.
- Do not use the controller at the following locations.
 - Areas where leakage of flammable gas may be expected
 - Places where large amounts of oil mist exist
 - Locations where external air may enter the room directly (This may cause "condensation")
 - Locations where high-frequency emissions are generated
 - Locations where voltage fluctuation frequently occurs
- Do not wash with water.

(NOTICE)

The English text is the original instructions. Other languages are translation of the original instructions.

Specifications

Model No.	CZ-256ESMC3	Clock	Precision	± 30 seconds/month (at normal temperature 25 °C) *Adjust periodically.	
Dimensions [H × W × D]	240 × 280 × (20 + 65) mm		Holding time	100 days (at normal temperature 25 °C with full charge) *Approx. 8 hours are required for full charge.	
Weight	2.7 kg		Number of connectable units per link*1	Up to 100 units of the combined total of the following	
Temperature/Humidity range	0 °C to 40 °C / 20 % to 80 % (no condensation) Indoor use only.	• Indoor unit - Up to 64 units*2			
Rated voltage/ Rated frequency	Single phase 100-240 V ~ 50-60 Hz	• Outdoor unit - Up to 30 units			
Power consumption	Max. 20 W	• Central control device - Up to 10 units			





*1: The maximum number of connectable units is shown below.

- When using only this unit: 128 indoor units and 60 outdoor units
- When connecting a Communication Adaptor: 256 indoor units and 120 outdoor units

*2: The number of indoor units includes the Interface Adaptor.

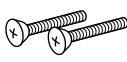
Supplied accessories

< >: Number of pieces

Screw <4> (M4×10)		Washer <4>	
Nut <4> (M4)		Clamper <4>	
Instructions and License List (DVD), Quick Reference, Installation Instructions			

* Wiring are not included (field supplied item).

Dimensions (Part Names)

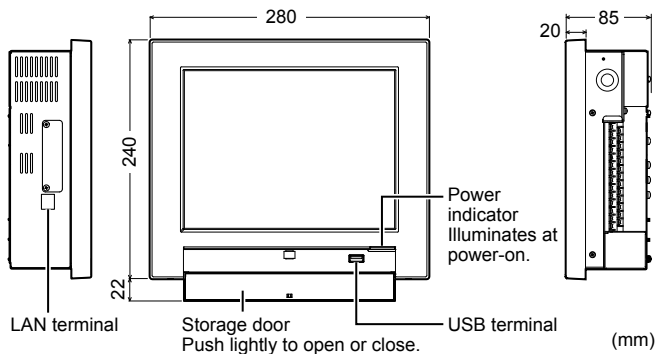

Symbols on the controller

 This symbol refers to "Protective earth".

Caution for Network Connection

- Connecting to Internet will enable you to operate the unit and check the status using a PC from a remote location.
- When connecting to Internet, implement security measures against illegal access from outside. For detailed connection and setup method, consult the network administrator.

Installation Precautions

Installation Location

- Avoid the following locations for installation.
 - Under direct sunlight
 - Location near heat source
 - Location where the controller will be splashed with water or affected by dampness or humidity
 - Uneven surface
 - Location that is subject to excessive vibration or physical impacts. (Fixing screws may come off, and the controller may drop.)
- Install the controller vertically to the floor.
- Install the controller at a location with suitable temperature and humidity for using.
- Do not install controller at the locations with the equipment (medical equipment, etc.) which generates the high-frequency emissions. (It may interfere with the equipment and may cause accidents due to malfunction.)
- Install at least 1 m away from TV, radio, PC. etc. (To prevent fuzzy images or noise)

General Precautions on Wiring

- Regulations on wire diameters differ from locality to locality. For field wiring rules, please refer to your LOCAL ELECTRICAL CODES before beginning. You must ensure that installation complies with all relevant rules and regulations.
- Use the field supplied wiring with at least 1 mm in thickness of insulation part including the sheath.
- Connect all wiring tightly to prevent the terminal board from loosening when the wiring connection part is pulled by an external force. (Otherwise, fire or overheating may occur.)
- Using putty (field supplied item), etc., fill the hole of the control box through which the wiring passes.
- Do not pass the power supply wiring and other wirings through the same conduit. Keep as long a distance as possible between them to alleviate the influence of noise.
- Do not run the power supply wiring and other wiring in the same conduit or bundle them together. (An operational error from noise may occur.)
- Do not bury the wiring in the ground.

Mounting

Design Control Box

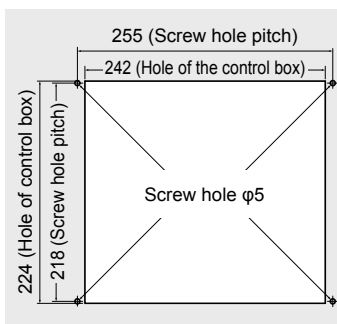

Mounting Position

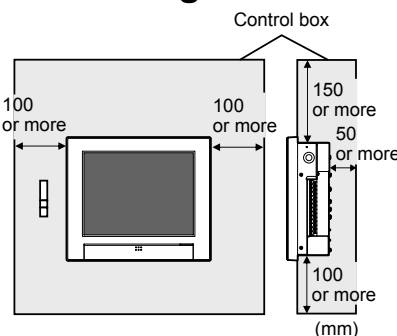

How to Mount (Control Box)

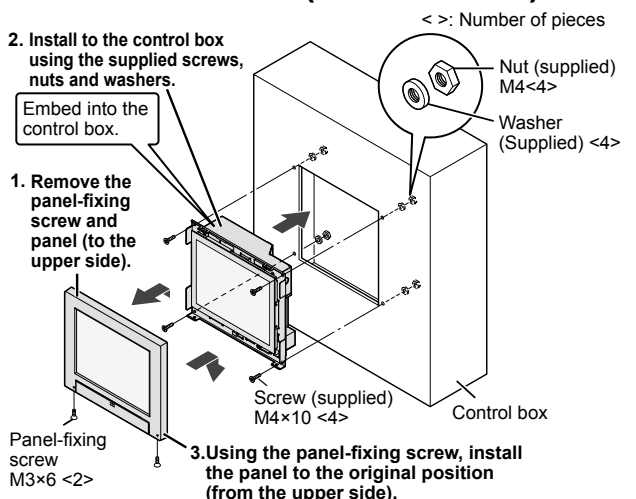

To ensure proper airflow (for heat dissipation) inside the control box, provide vents (slits, etc.) both on the upper part and lower part (or bottom side) of the right and left sides.

- Do not allow the temperature inside the control box to exceed 40 °C.
- Be careful not to block the above vents.

Preparations for Wiring

■ Power Supply Wiring

- Be sure to use a dedicated line for power source.
- Be sure to earth this controller.
- Do not connect the earth wiring to those of gas pipe, water pipe, lighting rod, telephone, etc.

● Type of wiring

- Use a flexible wiring of 2 mm² (Recommended).
- Use the standard power supply wiring for Europe (such as H05RN-F or H07RN-F which conform to CENELEC (HAR) rating specifications) or use the wiring based on IEC standard (60245 IEC57, 60245 IEC66).

● Total Wire Length : 30 m or less

■ Inter-Unit Control Wiring

● Type of wiring

- Use a flexible shield wiring of 0.5 to 2 mm².
- No polarity

● Total Wire Length : 1000 m or less

● Number of connectable units and devices : (→ P.2 “Specifications”)

■ Communication Adaptor Control Wiring

(When connecting a Communication Adaptor)

- Polarity (+/-) present
- Number of connectable Communication Adaptor: up to 7 units
- For the type of wiring and total wiring length, see “Installation Instructions” supplied with the Communication Adaptor.

■ External I/O Wiring

(When connecting external equipment)

● Type of wiring

- Use a flexible wiring of 0.5 to 2 mm².

● Wire Length : 20 m or less

Attention

- When using the controller at a location susceptible to noise, use a shield wiring.

■ LAN Cable (When connecting to a network)

● Type of wiring

- Category 5 or above straight cable

● Wire Length : 100 m or less

Attention

- Ground the shield on both sides of shield wiring, otherwise an operation error from noise may occur.

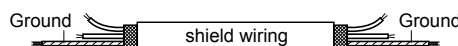

Wiring

Basic Wiring Diagram

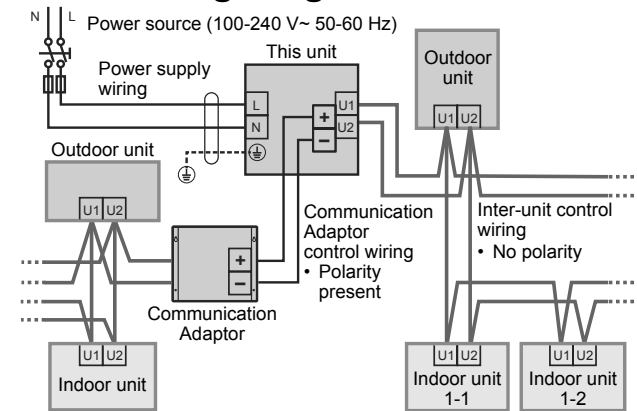

1. Turn the circuit breaker off before connecting the wiring

2. How to Attach the Ring Pressure Terminal

● For power supply wiring

Process the end of each wiring, and attach the ring pressure terminal (field supplied item).

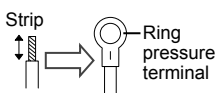

● For shield wiring

Process the end of the each wiring and attach the ring pressure terminal (field supplied item).

① Remove wiring coat.

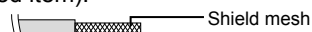

② Cover with the tape.



③ Attach ring pressure terminal.

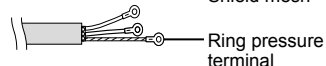

3. Remove the power switch cover

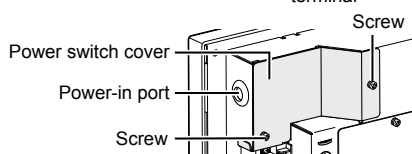

4. Wiring

① Connect the power supply wiring.

- Connect the power supply wiring and the earth wiring to the power supply terminal board and the earth terminal board*³ (on the sheet metal case) respectively.
- *3: Use earth terminal board as protective earth
- Do not over-tighten. (The screw may be damaged.)

② Connect the inter-unit control wiring.

- Connect the shield part of the shield wiring to No. 0 (FG*⁴) of the signal terminal board (TB2).
- *4: Functional Ground
- Do not over-tighten. (The screw may be damaged.)
- There is no polarity.

③ Connect the Communication Adaptor control wiring.

- Make sure the polarities (+/-) are correct.

Attention

- Read the “Installation Instructions” supplied with the Communication Adaptor.

④ Connecting external equipment.

Attention

- See “Connecting to External Equipment” (P.5).

⑤ Fix the power supply wiring and other communication wirings with the clumper (supplied) securely. (Do not apply tensile force on the terminal connection part.)

⑥ Connect the LAN cable.

⑦ After all wiring arrangements are complete, turn the circuit breaker on.

- Before power on, measure the voltage of the power supply terminal board, and check it for the specified voltage. Turning the power on with a voltage other than the specified one may blow the fuse. If this occurs, no power is supplied, and this unit may need to be replaced.

Wiring (continued)

*4: Functional Ground

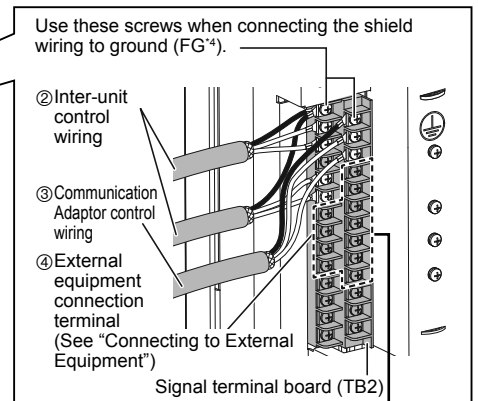
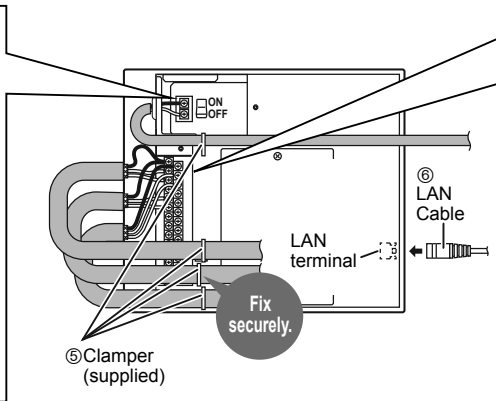
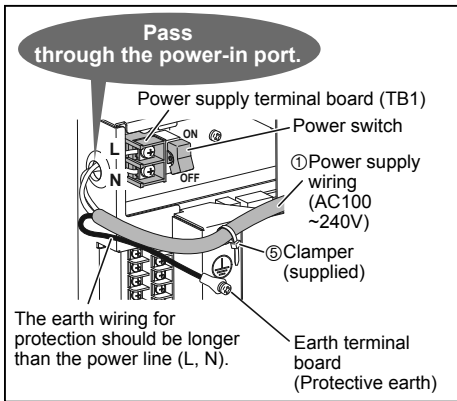

- If the power supply wiring is mistakenly connected to a terminal board other than the power supply terminal board, the devices connected to this controller or this controller will malfunction.

Signal terminal board (TB2) connection

Connect the shield wiring for the inter-unit control wiring to ground. (FG*4)	FG*4	0		14	FG*4	Connect the Communication Adaptor control wiring. (ADAPT +-,FG*4)
Connect to inter-unit control wiring (LINK1)	U1	1		15	+	
	U2	2		16	-	
			3	17		
Connect to inter-unit control wiring (LINK2)	U1	4		18		
	U2	5		19		

Connecting to External Equipment

- Non-voltage contact "a"
- Keep the external I/O wiring lengths of 20 meters or less. If a longer length is needed, use a Communication Adaptor or relay.
- A voltage of DC5 V (approx. 10 mA) is applied to the contact to detect the input signal.
- Do not apply an external voltage to the input terminal.
- The contact allowable voltage and current for the output signal terminal are max. DC30 V and 0.5 A respectively.

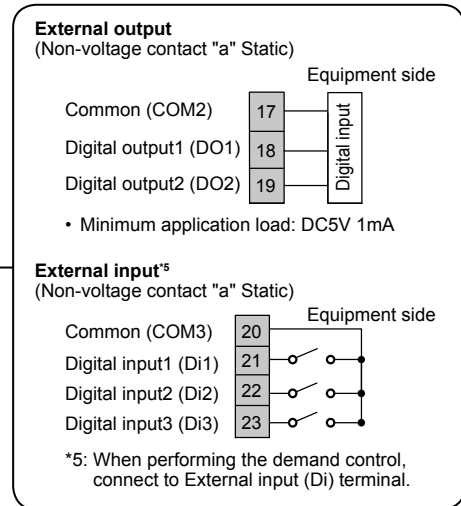
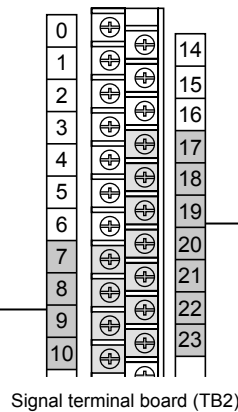
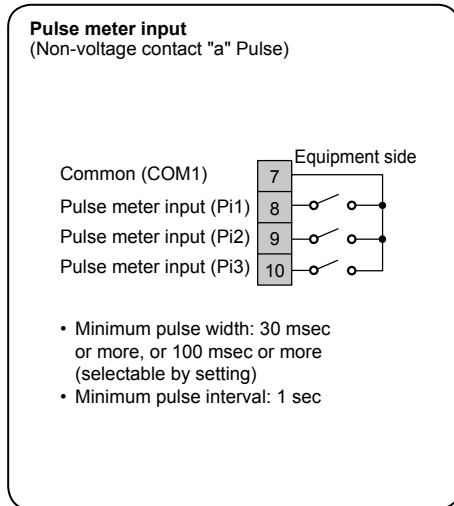

Setting and Test Operation

- ① Turn on all of the indoor units and the outdoor units.
- ② Turn on the Communication Adaptor (only when connected), and make the necessary settings. (See "Installation Instructions" supplied with the Communication Adaptor.)
- ③ Turn on this unit.
- ④ Attach the power switch cover to the original position.
 - Do not allow the wirings to be caught.
- ⑤ Refer to "Quick Reference" and check the following.
 - Check if the clock setting and the number of connected units are correctly displayed.
- ⑥ Refer to one of "Service Manual", "Test Run Service Manual" and "Technical Data", and check the following.
 - Set the central address.
 - Make other necessary settings (unit name, area setting, distribution setting, etc.).
 - Check if the indoor unit, etc. can be operated properly using this unit, and correct statuses are displayed.
 - Make the communication setting with the air conditioner.
 - Check and confirm the connection configuration.

