

TECHNICAL CATALOGUE

MONO SPLIT

RAK-18RPD
RAK-25RPD
RAK-35RPD
RAK-42RPD
RAK-50RPD



RAC-18WPD
RAC-25WPD
RAC-35WPD



RAC-42WPD
RAC-50WPD



HITACHI

Specifications in this catalogue are subject to change without prior notice in order for HITACHI to bring in the latest innovations to their customers

Whilst every effort is made to ensure that all dimensions and specifications are correct, any printers' error not rectified are outside the control of HITACHI, who cannot be held responsible for the same

CONTENTS

CONTENTS	1
1 SPECIFICATIONS	2
1.1. WALL TYPE (RAK-18RPD/25RPD/35RPD)	2
1.2. WALL TYPE (RAK-42RPD/50RPD)	3
1.3. WALL TYPE (RAC-18WPD/25WPD/35WPD)	4
1.4. WALL TYPE (RAC-42WPD/50WPD)	5
2 DIMENSIONAL DATA	6
2.1. WALL TYPE: RAK-18RPD/25RPD/35RPD/42RPD/50RPD	6
2.2. WALL TYPE: RAC-18WPD/25WPD/35WPD	7
2.3. WALL TYPE: RAC-42WPD/50WPD	8
3 CAPACITIES TABLE	9
3.1. CAPACITY CHARACTERISTIC CURVES	9
3.1.1. RAK-18RPD/RAC-18WPD	9
3.1.2. RAK-25RPD/RAC-25WPD	10
3.1.3. RAK-35RPD/RAC-35WPD	10
3.1.4. RAK-42RPD/RAC-42WPD	11
3.1.5. RAK-50RPD/RAC-50WPD	11
3.2. CORRECTION FACTORS ACCORDING TO PIPING LENGTH	12
3.3. CORRECTION FACTORS ACCORDING TO DEFROSTING OPERATION	14
4 SOUND DATA	15
4.1. RAC-18WPD	15
4.2. RAC-25WPD	16
4.3. RAC-35WPD	17
4.4. RAC-42WPD	18
4.5. RAC-50WPD	19
5 WORKING RANGE	20
5.1. POWER SUPPLY	20
5.2. WORKING RANGE	20
6 ELECTRICAL DATA	21
6.1. INDOOR UNIT	21
6.2. OUTDOOR UNIT	21
7 WIRING DIAGRAM	22
7.1. RAK-18RPD/25RPD/35RPD/42RPD/50RPD	22
7.2. RAC-18WPD/25WPD/35WPD	23
7.3. RAC-42WPD/50WPD	24
8 REFRIGERANT CYCLE	25
8.1. WALL TYPE: RAK/C-18R/WPD,RAK/C-25R/WPD,RAK/C-35R/WPD	25
8.2. WALL TYPE: RAK/C-42R/WPD,RAK/C-50R/WPD	25
9 CONTROL AND FUNCTION	26
9.1. WIRELESS REMOTE CONTROL FUNCTION	26
9.2. AUTO CHANGEOVER	28
9.3. SHIFT VALUE	28
9.4. OPERATION LOCK	29
9.5. SETTING THE PREVENTION OF MUTUAL INTERFERENCE	29
9.6. INTERMITTENT FAN SPEED SETTING	30
9.7. FAN SPEED SETTING IN THERMO OFF IN COOLING	31
9.8. ERROR CODE INFORMATION	32
9.9. ADDITIONAL FUNCTION VIA DIP-SWITCH SETTINGS	33
9.9.1. AUTO RESTART FUNCTION	33
9.9.2. HEATING/COOLING ONLY MODE SELECTION	33
10 OPTION LIST	34
10.1. WIRED REMOTE CONTROL – SPX-RCDB	34
10.1.1. SHIFT VALUE	34
10.1.2. ERROR CODE INFORMATION	35
10.2. H-LINK ADAPTOR – PSC 6RAD	37
10.2.1. SAFETY SUMMARY	37
10.2.2. INSTALLATION WORK	37
10.2.3. ELECTRICAL WIRING	38
10.2.4. DIP SWITCH SETTING	39
10.2.5. TEST RUN	40
10.3. DRY CONTACT (SPX-WDC3) APPLICATION (USING DIP SWITCH)	41
10.4. DISTRIBUTOR – SPX-DST1	43

1 SPECIFICATIONS

1.1. WALL TYPE (RAK-18RPD/25RPD/35RPD)

INDOOR	Unit	RAK-18RPD	RAK-25RPD	RAK-35RPD
Nominal capacity adjustable		no	no	no
Nominal Cooling capacity (min - max)	kW	2.00 (0.90 - 2.50)	2.50 (0.90 - 3.10)	3.50 (0.90- 4.00)
Cooling sensible capacity	kW	1.94	2.05	2.42
Nominal Heating capacity (min - max)	kW	2.50 (0.90 - 3.20)	3.40 (0.90- 4.40)	4.20 (0.90- 5.00)
Noise level cooling (sound pressure) (SL / L / M / H)	dB(A)	21/24/33/37	22/24/33/40	25/26/36/43
Noise level heating (sound pressure) (SL / L / M / H)	dB(A)	19/22/33/38	20/23/34/41	26/27/36/44
Noise level (sound power)	dB(A)	51	54	57
Air flow cooling mode (SL / L / M / H)	m ³ /h	312 / 350 / 400 / 440	333 / 370 / 430 / 510	353 / 420 / 485 / 680
Air flow heating mode (SL / L / M / H)	m ³ /h	312 / 350 / 420 / 480	333 / 400 / 500 / 570	363 / 480 / 570/ 780
Fan Motor	W	30	30	30
Dehumidification	l/h	1.2	1.4	1.6
Dimensions (H x W x D)	mm	280 x 780 x 230	280 x 780 x 230	280 x 780 x 230
Weight	kg	8.5	8.5	8.5
Colour		Star White (N9.3)	Star White (N9.3)	Star White (N9.3)
Condensate Drain	mm	φ 16	φ 16	φ 16
Running current (C/H)	A	1.09-4.39/1.09-4.22	1.09-5.61/1.09-6.52	1.09-6.35/1.09-7.39
Power supply		220-230V	220-230V	220-230V
Cable section (interconnection)	mm ²	1.50x 3+EARTH/-	1.50x 3+EARTH/-	1.50x 3+EARTH/-
Piping diameter (Liq / Gas)	Inch	1/4" / 3/8"	1/4" / 3/8"	1/4" / 3/8"
Drain diameter (ext)	mm	φ 16	φ 16	φ 16
Remote control (standard/optional)		RAR-6N1/SPX-RCDB	RAR-6N1/SPX-RCDB	RAR-6N1/SPX-RCDB
Filter				
ACL Filter		activated carbon	activated carbon	activated carbon
ACL part name		SPX-CFH25	SPX-CFH25	SPX-CFH25
Pre-filter(Standard/Optional)		WASHABLE/ Stainless-SPX-SPF8	WASHABLE/ Stainless-SPX-SPF8	WASHABLE/ Stainless-SPX-SPF8

NOTE:

1. The nominal cooling and heating capacity is the combined capacity of the HITACHI standard split system, and are based on the ISO 5151.

Operation Conditions		Cooling	Heating
Indoor Air Inlet Temperature	dB	27.0 °C	20.0 °C
	WB	19.0 °C	15.0 °C
Outdoor Air Inlet Temperature	dB	35.0 °C	7.0 °C
	WB	24.0 °C	6.0 °C
Piping Length: 5.0 meters; Piping Lift: 0 meter dB: Dry Bulb; WB: Wet Bulb			

2. The Sound Pressure Level is based on the following conditions:

- 0.8 meter beneath indoor height center
- 1 meter from Discharge grille

The above data was measured in an anechoic chamber. Please take into consideration reflected sound of your specific site

1.2. WALL TYPE (RAK-42RPD/50RPD)

INDOOR	Unit	RAK-42RPD	RAK-50RPD
Nominal capacity adjustable		no	no
Nominal Cooling capacity (min - max)	kW	4.20(1.70- 5.00)	5.00 (1.90- 5.20)
Cooling sensible capacity	kW	3.25	3.43
Nominal Heating capacity (min - max)	kW	5.40(1.70- 6.00)	6.00 (2.2- 7.30)
Noise level cooling (sound pressure) (SL / L / M / H)	dB(A)	25/28/39/46	25/28/39/46
Noise level heating (sound pressure) (SL / L / M / H)	dB(A)	27/31/39/46	27/31/39/46
Noise level (sound power)	dB(A)	60	60
Air flow cooling mode (SL / L / M / H)	m ³ /h	353 / 410 / 540 / 720	353 / 410 / 540 / 750
Air flow heating mode (SL / L / M / H)	m ³ /h	380 / 500 / 610 / 800	380 / 500 / 610 / 820
Fan Motor	W	30	30
Dehumidification	l/h	1.8	2.0
Dimensions (H x W x D)	mm	280 x 780 x 230	280 x 780 x 230
Weight	kg	8.5	8.5
Colour		Star White (N9.3)	Star White (N9.3)
Condensate Drain	mm	φ 16	φ 16
Running current (C/H)	A	1.30-7.39/2.17-8.70	1.30-8.70/2.17-11.96
Power supply		220-230V	220-230V
Cable section (interconnection)	mm ²	2.50x 3+EARTH/-	2.50x 3+EARTH/-
Piping diameter (Liq / Gas)	Inch	1/4" / 1/2"	1/4" / 1/2"
Drain diameter (ext)	mm	φ 16	φ 16
Remote control (standard/optional)		RAR-6N1/SPX-RCDB	RAR-6N1/SPX-RCDB
Filter			
ACL Filter		activated carbon	activated carbon
ACL part name		SPX-CFH25	SPX-CFH25
Pre-filter(Standard/Optional)		WASHABLE/ Stainless-SPX-SPF8	WASHABLE/ Stainless-SPX-SPF8

NOTE:

1. The nominal cooling and heating capacity is the combined capacity of the HITACHI standard split system, and are based on the ISO 5151.

Operation Conditions		Cooling	Heating
Indoor Air Inlet Temperature	dB	27.0 °C	20.0 °C
	WB	19.0 °C	15.0 °C
Outdoor Air Inlet Temperature	dB	35.0 °C	7.0 °C
	WB	24.0 °C	6.0 °C
Piping Length: 5.0 meters; Piping Lift: 0 meter dB: Dry Bulb; WB: Wet Bulb			

2. The Sound Pressure Level is based on the following conditions:

- 0.8 meter beneath indoor height center
- 1 meter from Discharge grille

The above data was measured in an anechoic chamber. Please take into consideration reflected sound of your specific site

1.3. WALL TYPE (RAC-18WPD/25WPD/35WPD)

OUTDOOR		RAC-18WPD	RAC-25WPD	RAC-35WPD	
Nominal Cooling capacity (min - max)	kW	2.00 (0.90 - 2.50)	2.50 (0.90 - 3.10)	3.50 (0.90- 4.00)	
Nominal Heating capacity (min - max)	kW	2.50 (0.90 - 3.20)	3.40 (0.90- 4.40)	4.20 (0.90- 5.00)	
Nominal cooling power input (min - max)	kW	0.419(0.25 - 1.01)	0.549(0.25 - 1.29)	0.941(0.25 - 1.46)	
Nominal heating power input (min - max)	kW	0.519(0.25 - 0.97)	0.733(0.25 - 1.50)	1.000(0.25 - 1.70)	
EER / COP		4.77/4.82	4.55/4.64	3.72/4.2	
SEER / SCOP		8.50/4.90	8.50/4.90	7.80/4.90	
Energy class (SEER/SCOP)		A+++/A++	A+++/A++	A++/A++	
Noise level cooling (sound pressure)	dB(A)	44	46	48	
Noise level heating (sound pressure)	dB(A)	45	47	49	
Noise level (sound power)	dB(A)	58	60	61	
Air flow (Cooling / Heating)	m ³ /h	1860 / 1620	1860 / 1620	1920 / 1620	
Dimensions (H x W x D)	mm	548× 750× 288	548× 750× 288	548× 750× 288	
Weight	kg	32.5	32.5	32.5	
Colour (Munsell Code)		Beige (5Y7/2)	Beige (5Y7/2)	Beige (5Y7/2)	
Power supply	V/Ph/Hz	230V / 1Ph / 50Hz	230V / 1Ph / 50Hz	230V / 1Ph / 50Hz	
Recommended fuse size	A	15	15	15	
Starting current(C/H)	A	2.46/2.93	3.08/3.87	4.81/5.11	
Running current (C/H)	A	1.09-4.39/1.09-4.22	1.09-5.61/1.09-6.52	1.09-6.35/1.09-7.39	
Cable section (power)	mm ²	1.50x 2+EARTH	1.50x 2+EARTH	1.50x 2+EARTH	
Cable section (Interconnection)	mm ²	1.50x 3+EARTH	1.50x 3+EARTH	1.50x 3+EARTH	
Piping diameter (Liq / Gas)	Inch	1/4" / 3/8"	1/4" / 3/8"	1/4" / 3/8"	
Minimum piping length	m	3	3	3	
Maximum piping length / height difference	m	20 / 10	20 / 10	20 / 10	
Current quantity of refrigerant / Chargeless	kg	0.870	0.870	0.870	
Chargeless length / Additional refrigerant charge	m / g/m	20/-	20/-	20/-	
Working range (cooling / heating)	°C	-10°C~43°C/-15~21°C	-10°C~43°C/-15~21°C	-10°C~43°C/-15~21°C	
Refrigerant		R32	R32	R32	
Condenser Fan		Propeller Fan	Propeller Fan	Propeller Fan	
Compressor	Type		ROTARY	ROTARY	ROTARY
	Oil Charge	mL	320±20	320±20	320±20
	Oil Type		ACS-68R or equivalent	ACS-68R or equivalent	ACS-68R or equivalent
	Coil resistance	Ω	2.167 at 20°C	2.167 at 20°C	2.167 at 20°C
	Quantity		1	1	1

NOTE:

1. The Sound Pressure Level is based on the following conditions:

- 1 meter from the unit front surface and 1 meter from floor level

The above data was measured in an anechoic chamber. Please take into consideration reflected sound of your specific site

1.4. WALL TYPE (RAC-42WPD/50WPD)

OUTDOOR		RAC-42WPD	RAC-50WPD
Nominal Cooling capacity (min - max)	kW	4.20 (1.70- 5.00)	5.00 (1.90- 5.20)
Nominal Heating capacity (min - max)	kW	5.40 (1.7- 6.00)	6.00 (2.2- 7.30)
Nominal cooling power input (min - max)	kW	1.120(0.30 - 1.70)	1.471(0.30 - 2.10)
Nominal heating power input (min - max)	kW	1.317(0.50 - 2.10)	1.558(0.50 - 2.75)
EER / COP		3.75/4.1	3.40/3.85
SEER / SCOP		7.50/4.60	7.35/4.60
Energy class (SEER/SCOP)		A++/A++	A++/A++
Noise level cooling (sound pressure)	dB(A)	49	49
Noise level heating (sound pressure)	dB(A)	50	50
Noise level (sound power)	dB(A)	63	63
Air flow (Cooling / Heating)	m ³ /h	2160 / 2160	2160 / 2160
Dimensions (H x W x D)	mm	600x792x299	600x792x299
Weight	kg	39	39
Colour (Munsell Code)		Beige (5Y7/2)	Beige (5Y7/2)
Power supply	V/Ph/Hz	230V / 1Ph / 50Hz	230V / 1Ph / 50Hz
Recommended fuse size	A	25	25
Starting current(C/H)	A	5.10/5.99	6.69/7.09
Running current (C/H)	A	1.30-7.39/2.17-8.70	1.30-8.70/2.17-11.96
Cable section (power)	mm ²	2.50x 2+EARTH	2.50x 2+EARTH
Cable section (Interconnection)	mm ²	2.50x 3+EARTH	2.50x 3+EARTH
Piping diameter (Liq / Gas)	Inch	1/4" / 1/2"	1/4" / 1/2"
Minimum piping length	m	3	3
Maximum piping length / height difference	m	20 / 10	20 / 10
Current quantity of refrigerant / Chargeless	kg	1.050	1.050
Chargeless length / Additional refrigerant charge	m / g/m	20/-	20/-
Working range (cooling / heating)	°C	-10°C~43°C/-15~21°C	-10°C~43°C/-15~21°C
Refrigerant		R32	R32
Condenser Fan		Propeller Fan	Propeller Fan
Compressor	Type		2 Cylinder Rotary
	Oil Charge	mL	480±20
	Oil Type		ACS-68R or equivalent
	Coil resistance	Ω	1.354 at 20°C
	Quantity		1

NOTE:

1. The Sound Pressure Level is based on the following conditions:

- 1 meter from the unit front surface and 1 meter from floor level

The above data was measured in an anechoic chamber. Please take into consideration reflected sound of your specific site

2 DIMENSIONAL DATA

2.1. WALL TYPE :RAK-18RPD/25RPD/35RPD/42RPD/50RPD

Unit : mm

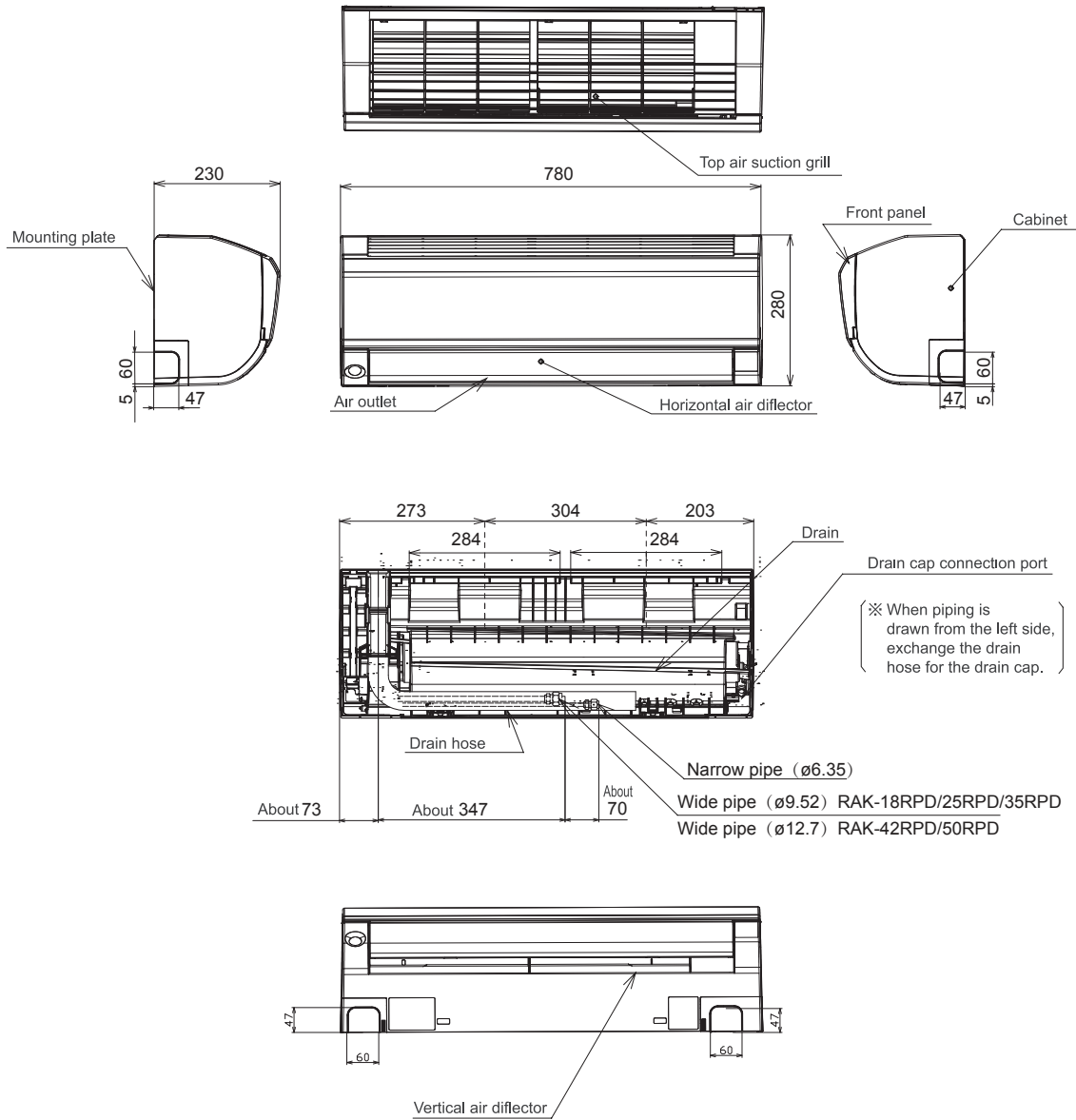

2.2. WALL TYPE :RAC-18WPD/25WPD/35WPD

Unit : mm

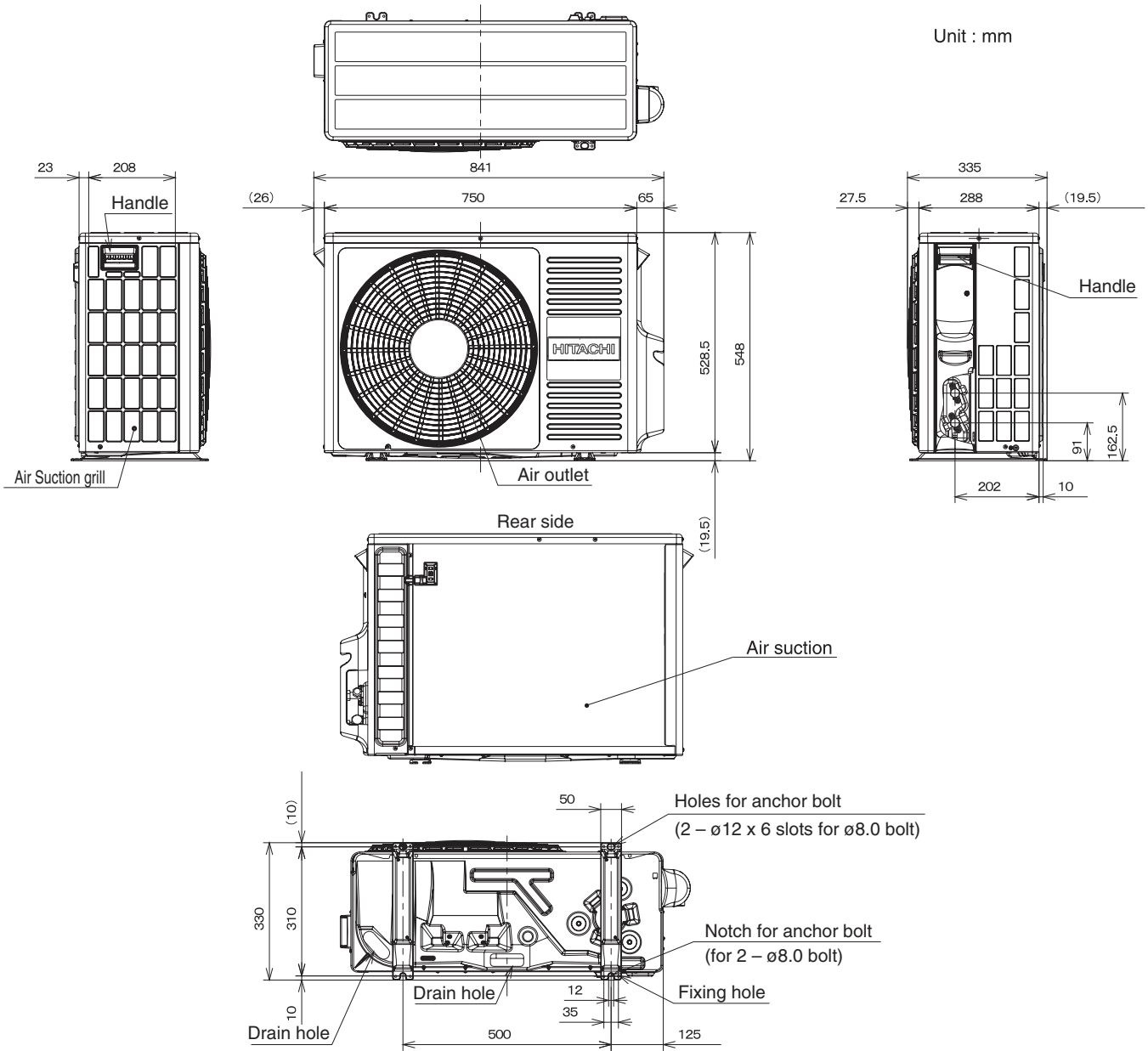

2.3. WALL TYPE:RAC-42WPD/50WPD

Unit : mm

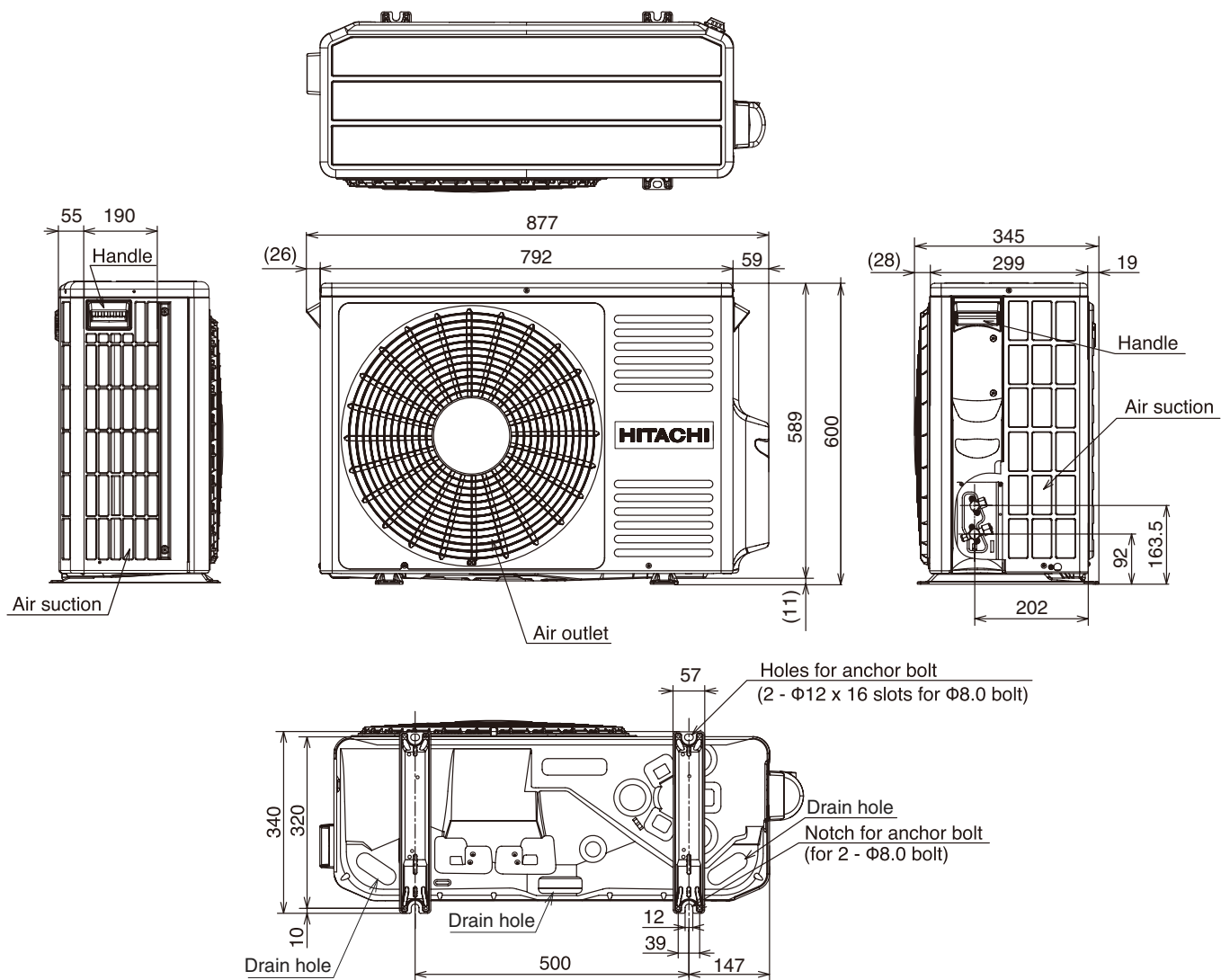

3 CAPACITIES TABLE

3.1. CAPACITY CHARACTERISTIC CURVES

The following charts show the characteristics of outdoor unit capacity, which corresponds with the operating ambient temperature of outdoor unit.

Conditions:

- ① Pipe length / height difference : 5m / 0m
 ② Indoor fan speed at High mode

③ Capacity loss due to white frost and defrost operation is not included.

3.1.1. RAK-18RPD/RAC-18WPD

COOLING [50Hz, 230V]

INDOOR		OUTDOOR TEMPERATURE (°CDW)																				
EWB	EDB	-10			21			27			32			35			40			43		
°C	°C	TC	SHC	PI	TC	SHC	PI	TC	SHC	PI	TC	SHC	PI	TC	SHC	PI	TC	SHC	PI	TC	SHC	PI
12.0	18	1581	1441	238	1790	1922	282	1657	1774	332	1640	1765	385	1580	1688	402	1480	1591	432	1420	1513	448
14.0	20	1581	1441	238	1924	1922	282	1790	1792	336	1760	1765	390	1700	1707	406	1580	1591	436	1520	1533	457
16.0	22	1581	1534	241	2057	1922	286	1905	1792	340	1880	1765	394	1820	1707	415	1700	1591	444	1640	1533	461
18.0	25	1695	1644	245	2190	2088	289	2019	1940	344	2000	1921	398	1920	1843	415	1800	1727	448	1720	1649	465
19.0	27	1752	1700	249	2267	2199	293	2095	2032	348	2080	2018	402	2000	1940	419	1880	1824	448	1800	1746	465
22.0	30	1943	1681	249	2514	2180	293	2324	2014	348	2300	1998	406	2220	1921	423	2000	1862	465	1860	1824	490
24.0	32	2076	1681	252	2686	2180	297	2476	2014	352	2460	1998	406	2360	1921	427	2080	1901	478	1900	1882	507

HEATING [50Hz, 230V]

INDOOR		OUTDOOR TEMPERATURE (°CDW)																						
EDB	-15	-10			-7			-5			0			7			10			15				
°C	TC	SHC	PI	TC	SHC	PI	TC	SHC	PI	TC	SHC	PI	TC	SHC	PI	TC	SHC	PI	TC	SHC	PI	TC	SHC	PI
16	1975		832	2350		900	2568		948	2549		894	2510		749	2471		565	2698		608	3054		683
18	1988		826	2363		895	2584		939	2568		883	2530		737	2486		542	2711		584	3077		656
20	2000		820	2375		889	2600		930	2586		871	2550		725	2500		519	2725		560	3100		629
22	2013		814	2388		883	2616		921	2604		860	2570		712	2514		496	2739		536	3123		602
24	2025		808	2400		877	2632		912	2622		848	2590		700	2529		473	2753		512	3146		575

EWB : Evaporator Wet Bulb temperature (°C)

EDB : Evaporator Dry Bulb temperature (°C)

(°CDB) : Outdoor Unit Inlet Air Dry Bulb Temperature (°C)

TC : Total Capacity (W)

SHC : Sensible Heating Capacity (W)

PI : Power Input

3.1.4. RAK-42RPD/RAC-42WPD

COOLING [50Hz, 230V]

Table with columns for Indoor (EWB, EDB) and Outdoor Temperature (°CDW) ranging from -10 to 43. Rows show TC, SHC, and PI values for various indoor temperatures from 12.0 to 24.0.

HEATING [50Hz, 230V]

Table with columns for Indoor (EDB) and Outdoor Temperature (°CDW) ranging from -15 to 15. Rows show TC, SHC, and PI values for various indoor temperatures from 16 to 24.

EWB : Evaporator Wet Bulb temperature (°C)
EDB : Evaporator Dry Bulb temperature (°C)
(°CDB) : Outdoor Unit Inlet Air Dry Bulb Temperature (°C)

TC : Total Capacity (W)
SHC : Sensible Heating Capacity (W)
PI : Power Input

3.1.5. RAK-50RPD/RAC-50WPD

COOLING [50Hz, 230V]

Table with columns for Indoor (EWB, EDB) and Outdoor Temperature (°CDW) ranging from -10 to 43. Rows show TC, SHC, and PI values for various indoor temperatures from 12.0 to 24.0.

HEATING [50Hz, 230V]

Table with columns for Indoor (EDB) and Outdoor Temperature (°CDW) ranging from -15 to 15. Rows show TC, SHC, and PI values for various indoor temperatures from 16 to 24.

EWB : Evaporator Wet Bulb temperature (°C)
EDB : Evaporator Dry Bulb temperature (°C)
(°CDB) : Outdoor Unit Inlet Air Dry Bulb Temperature (°C)

TC : Total Capacity (W)
SHC : Sensible Heating Capacity (W)
PI : Power Input

3.2. CORRECTION FACTORS ACCORDING TO PIPING LENGTH

Correction Factor for **Cooling Capacity** according to Piping Length

The cooling capacity should be corrected according to the following formula:

$$CCA = CC \times F$$

CCA: Actual Corrected Cooling Capacity (kcal/h)

CC: Cooling Capacity in the Performance Table (kcal/h)

F: Correction Factor Based on the Equivalent Piping Length

Correction Factor for **Heating Capacity** according to Piping Length

The heating capacity should be corrected according to the following formula:

$$HCA = HC \times F$$

HCA: Actual Corrected Heating Capacity (kcal/h)

HC: Heating Capacity in the Performance Table (kcal/h)

F: Correction Factor Based on the Equivalent Piping Length

The correction factors are shown in the following figure.

Equivalent Piping Length for:

- One 90° Elbow is 0.5m.
- One 180° Curve is 1.5m.

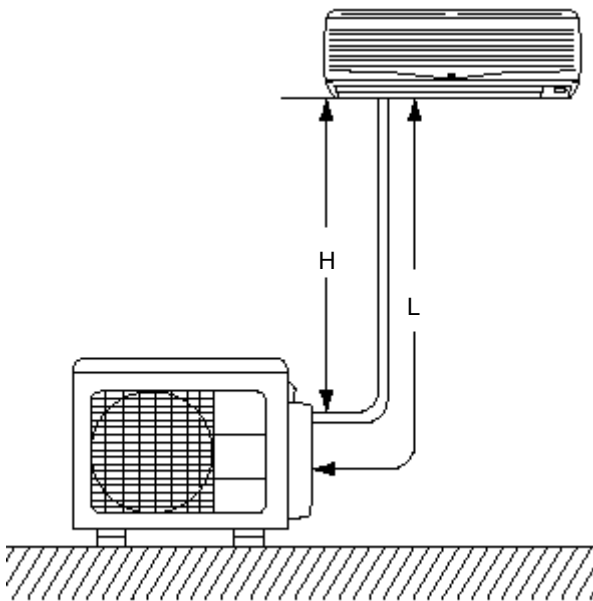

H: Vertical Distance Between Indoor Unit and Outdoor Units in Meters

L: Actual One-Way Piping Length Between Indoor Unit and Outdoor Unit in Meters

EL: Equivalent Total Distance Between Indoor Unit and Outdoor Unit in Meters (Equivalent One-Way Piping Length)

Models : RAK-18RPD、RAK-25RPD、RAK-35RPD
RAC-18WPD、RAC-25WPD、RAC-35WPD

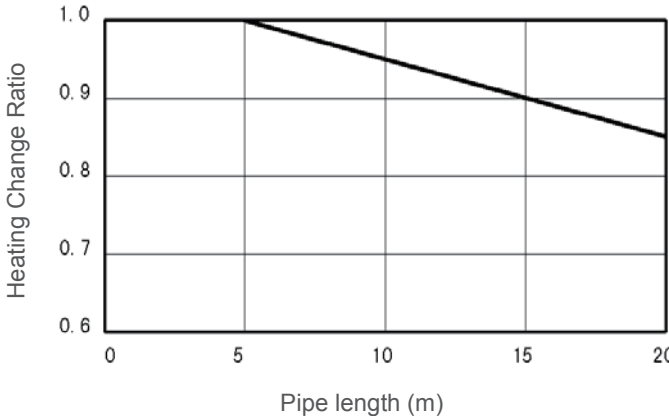
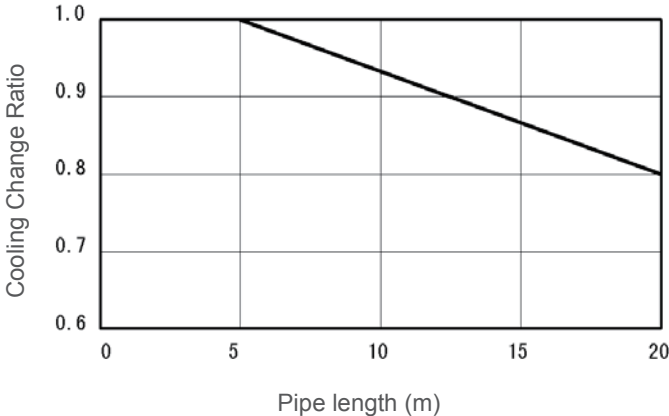

Models : RAK-42RPD、RAK-50RPD
RAC-42WPD、RAC-50WPD

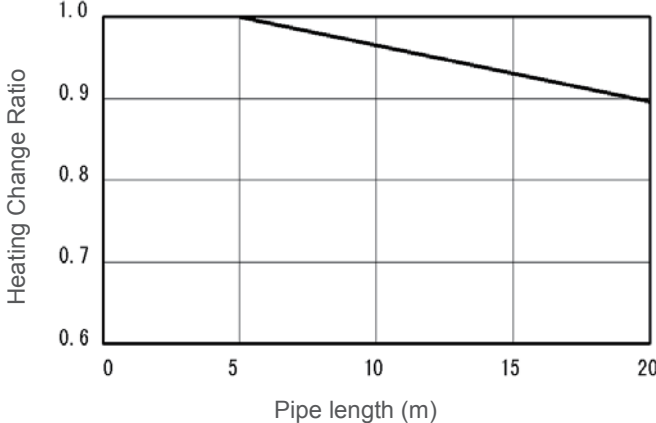
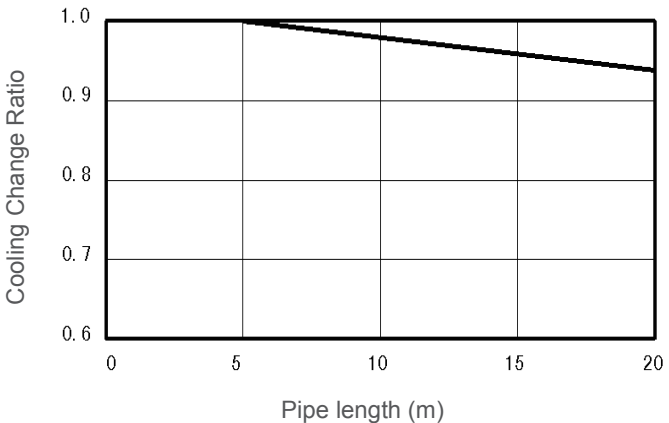

3.3. CORRECTION FACTORS ACCORDING TO DEFROSTING OPERATION

The heating capacity in the preceding paragraph, excludes the condition of the frost or the defrosting operation period. In consideration of the frost or the defrosting operation, the heating capacity is corrected by the equation below.

Corrected heating capacity = Defrost Correction factor x unit capacity

OUTDOOR TEMPERATURE (°CDB)	-15	-10	-7	-5	0	7	10	15
Correction factor (humidity rate85% RH)	0.95	0.95	0.89	0.85	0.81	1.0	1.0	1.0

Correction Factor

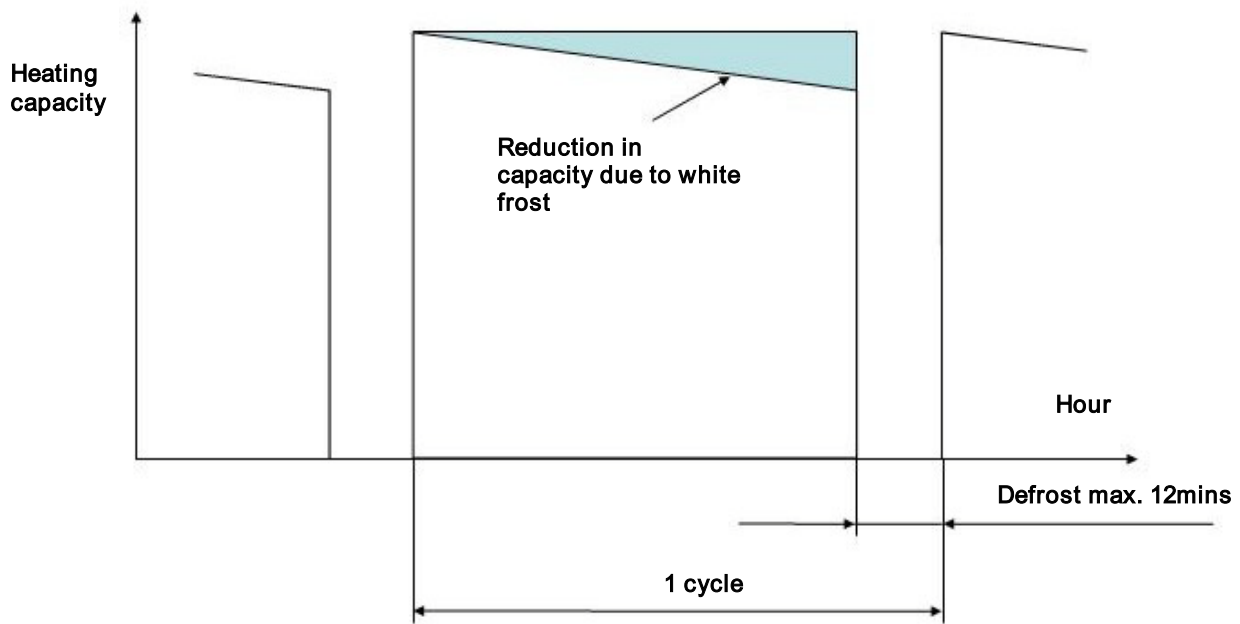

NOTE:

The correction factor is not valid for special conditions such as snowfall or operation in a transitional period.

4 SOUND DATA

4.1. RAC-18WPD

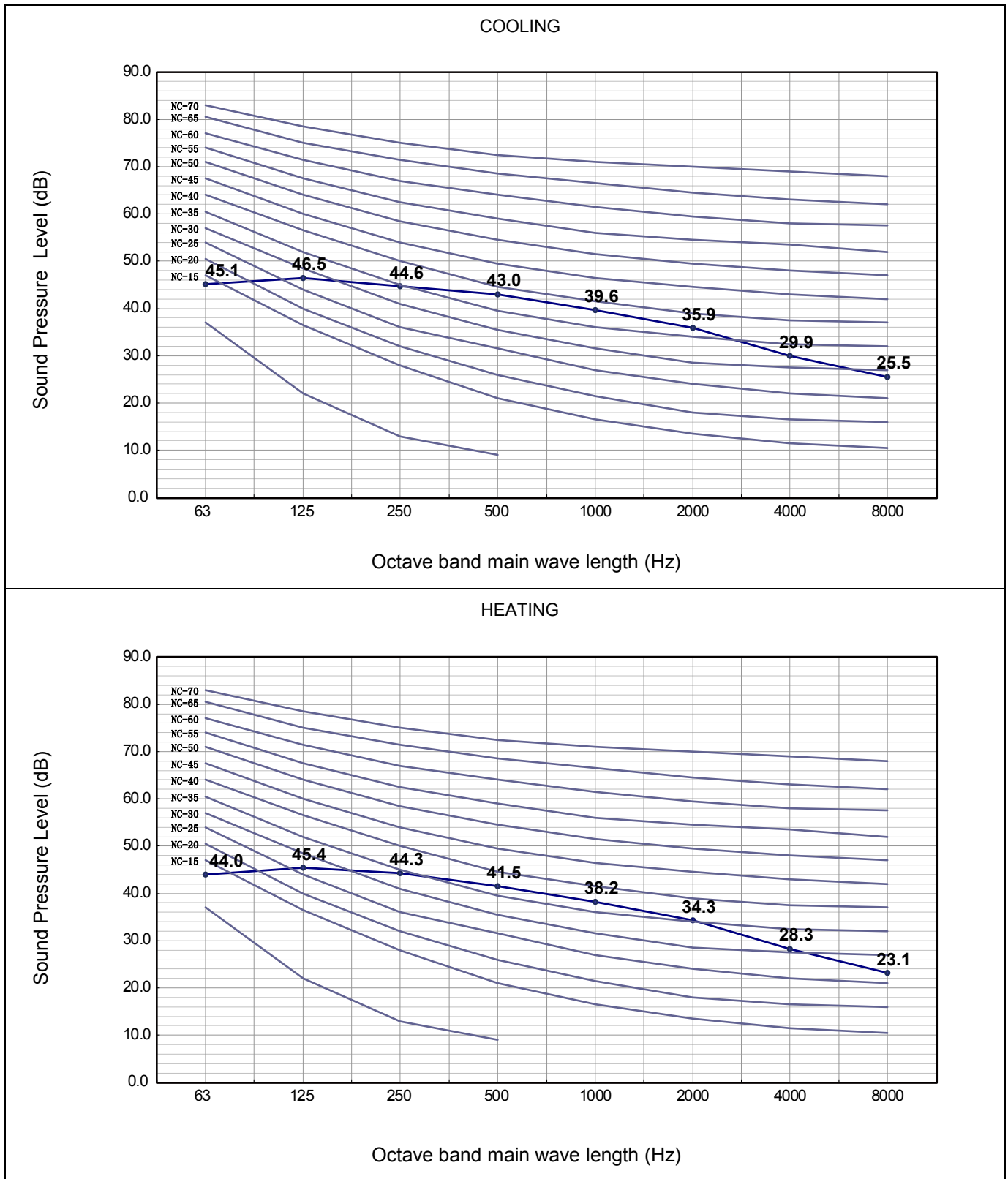

The Sound Pressure Level is based on the following conditions:

- 1 meter from the unit front surface and 1 meter from floor level

The above data was measured in an anechoic chamber. Please take into consideration reflected sound of your specific site

4.2. RAC-25WPD

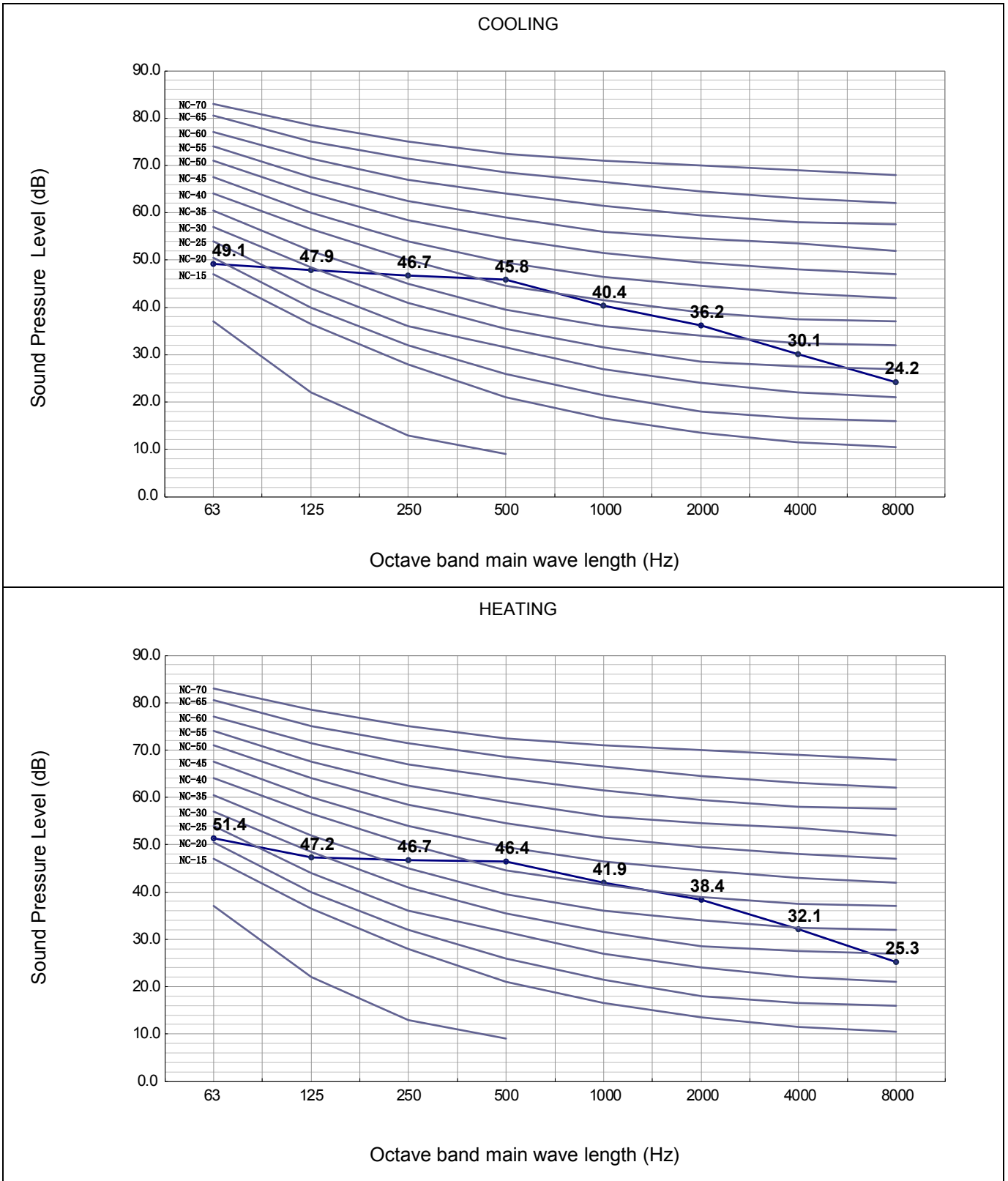

The Sound Pressure Level is based on the following conditions:

- 1 meter from the unit front surface and 1 meter from floor level

The above data was measured in an anechoic chamber. Please take into consideration reflected sound of your specific site

4.3. RAC-35WPD

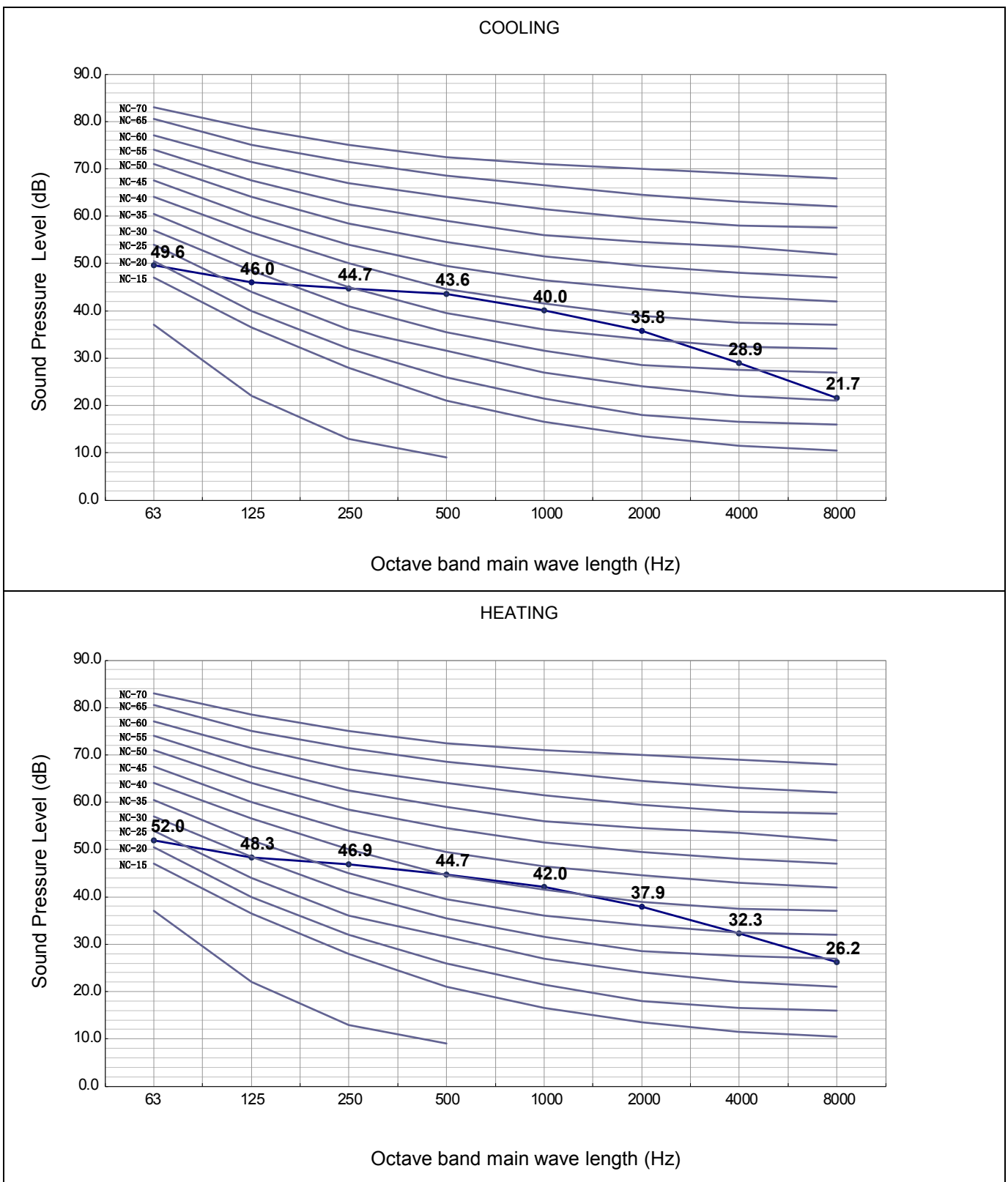

The Sound Pressure Level is based on the following conditions:

- 1 meter from the unit front surface and 1 meter from floor level

The above data was measured in an anechoic chamber. Please take into consideration reflected sound of your specific site

4.4. RAC-42WPD

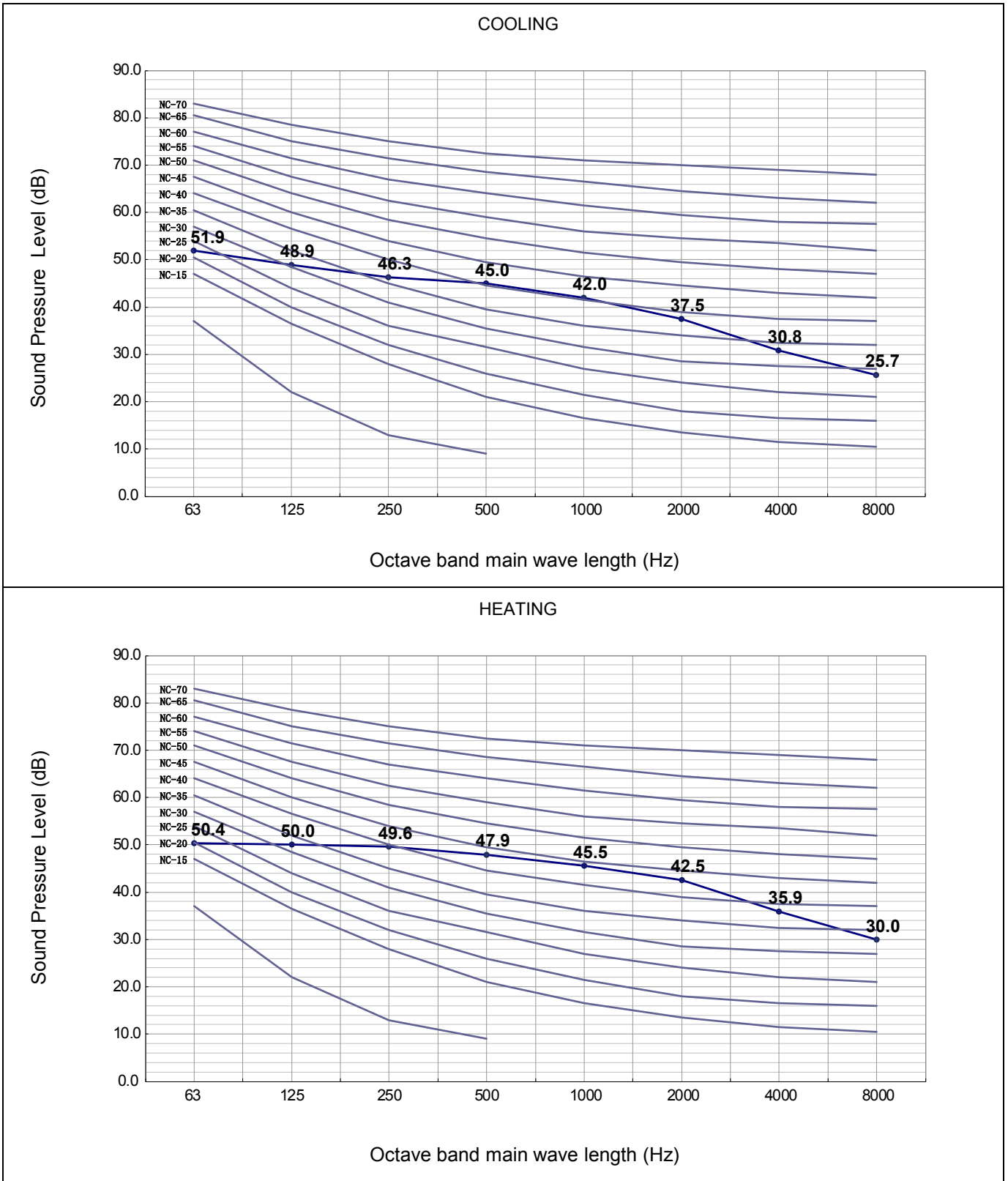

The Sound Pressure Level is based on the following conditions:

- 1 meter from the unit front surface and 1 meter from floor level

The above data was measured in an anechoic chamber. Please take into consideration reflected sound of your specific site

4.5. RAC-50WPD

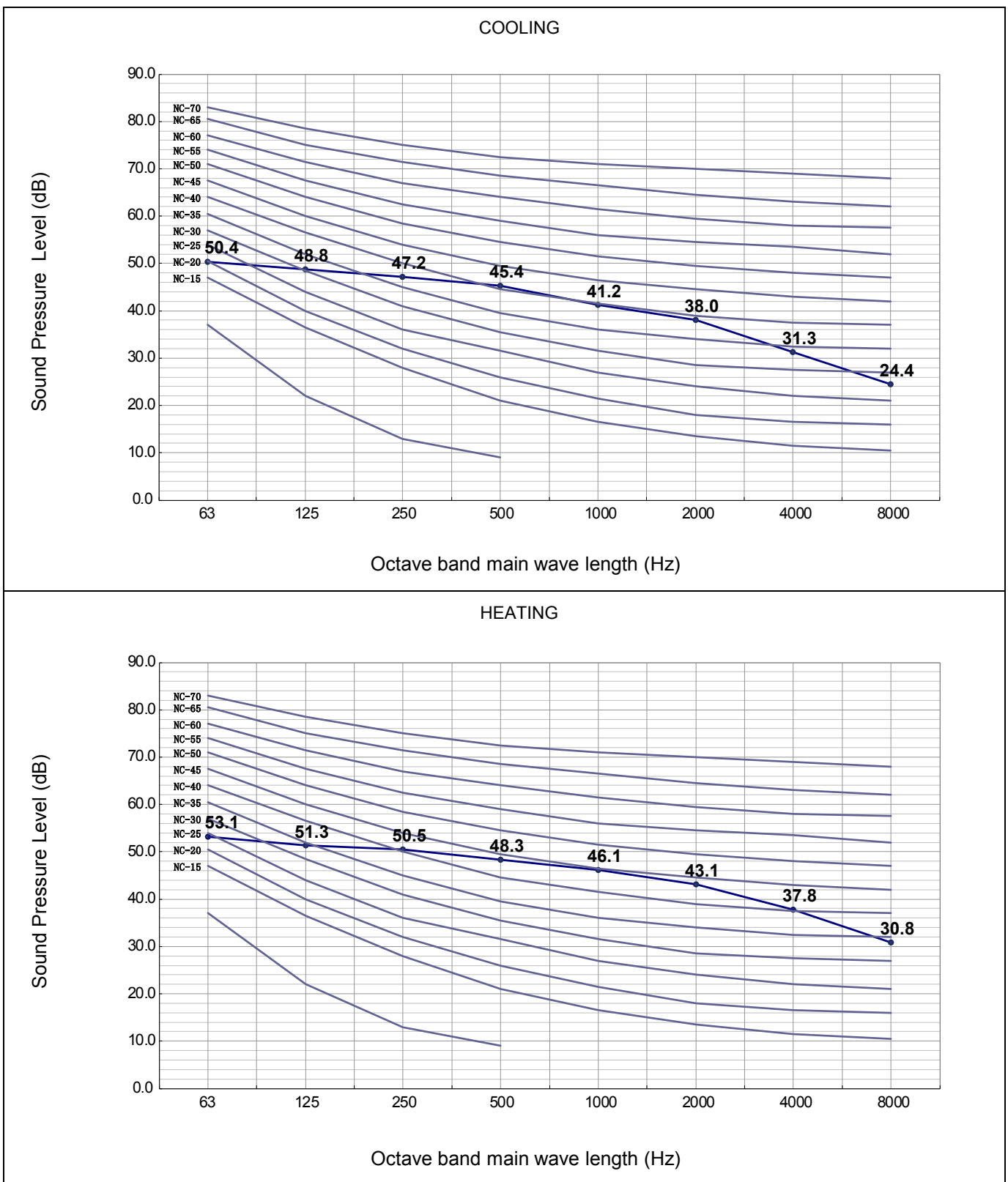

The Sound Pressure Level is based on the following conditions:

- 1 meter from the unit front surface and 1 meter from floor level

The above data was measured in an anechoic chamber. Please take into consideration reflected sound of your specific site

5 WORKING RANGE

5.1. POWER SUPPLY

Working Voltage	207V ~ 253V
Voltage Imbalance	Within a 3% Deviation from Each Voltage at the Main Terminal of Outdoor Unit
Starting Voltage	Higher than 85% of the Rated Voltage

5.2. WORKING RANGE

Applicable models:

RAC-18WPD
RAC-25WPD
RAC-35WPD
RAC-42WPD
RAC-50WPD

The temperature range is indicated in the following table.

Cooling

working range	min (°C)	max (°C)	rated (°C)
outdoor	-10	43	35
indoor	16	43	27

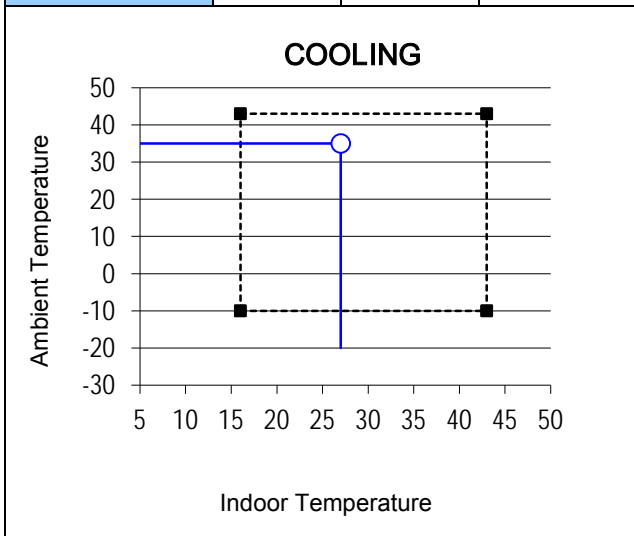

Heating

working range	min (°C)	max (°C)	rated (°C)
outdoor	-15	21	7
indoor	16	26	20

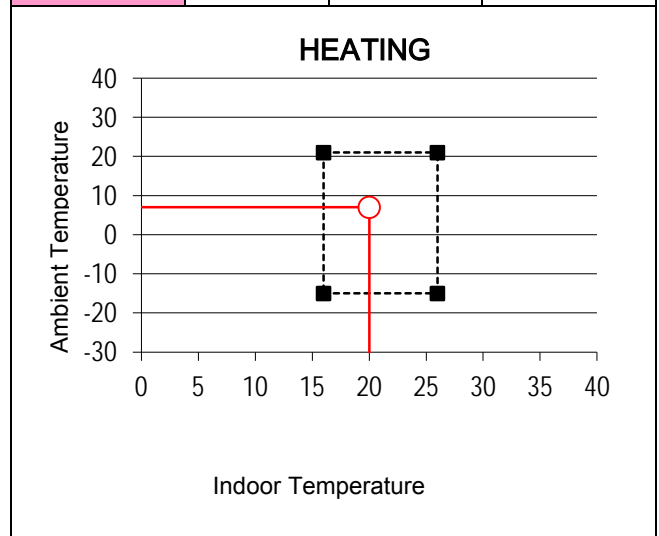

6 ELECTRICAL DATA

6.1. INDOOR UNIT

Model	Unit Main Power		Applicable Current		Indoor Fan Motor	
	VOL, PH, Hz	Fuse Rating (A)	STC	RNC	RNC	IPT
RAK-18RPD	230,1, 50	3.15	(C) 2.46 (H)2.93	(C) 4.39 (H)4.22	0.67	30
RAK-25RPD	230,1, 50	3.15	(C) 3.08 (H)3.87	(C) 5.61 (H)6.52	0.67	30
RAK-35RPD	230,1, 50	3.15	(C) 4.81 (H)4.20	(C) 5.11 (H)7.39	0.67	30
RAK-42RPD	230,1, 50	3.15	(C) 5.10 (H)5.99	(C) 7.39 (H)8.70	0.67	30
RAK-50RPD	230,1, 50	3.15	(C) 6.69 (H)7.09	(C) 8.70 (H)11.96	0.67	30

VOL: Rated Unit Power Supply Voltage (V)

Hz: Frequency (Hz)

STC: Starting Current (A)

RNC: Running Current (A)

PH: Phase (ϕ)

IPT: Input (W)

6.2. OUTDOOR UNIT

Model	Unit Main Power				Compressor Motor					
	VOL, PH, Hz	Fuse Rating (A)	Min (V)	Max (V)	Locked Rotor Ampere (A)	STC	Cooling Operation		Heating Operation	
							RNC	IPT	RNC	IPT
RAC-18WPD	230,1, 50	15	207	253	-	2.93	4.39	419	4.22	519
RAC-25WPD	230,1, 50	15	207	253	-	3.87	5.61	549	6.52	733
RAC-35WPD	230,1, 50	15	207	253	-	5.11	6.35	941	7.39	1000
RAC-42WPD	230,1, 50	25	207	253	-	5.99	7.39	1120	8.7	1317
RAC-50WPD	230,1, 50	25	207	253	-	7.09	8.7	1471	11.96	1558

VOL: Rated Unit Power Supply Voltage (V)

HZ: Frequency (Hz)

STC: Starting Current (A)

RNC: Running Current (A)

PH: Phase (ϕ)

IPT: Input (W)

NOTE:

1. The above compressor data is based on 100% capacity combination of indoor units at the rated operating frequency
2. This data is based on the same conditions as the nominal heating and cooling capacities.
3. The compressor started by an inverter, resulting in extremely low starting current.

7 WIRING DIAGRAM

7.1. RAK-18RPD/25RPD/35RPD/42RPD/50RPD

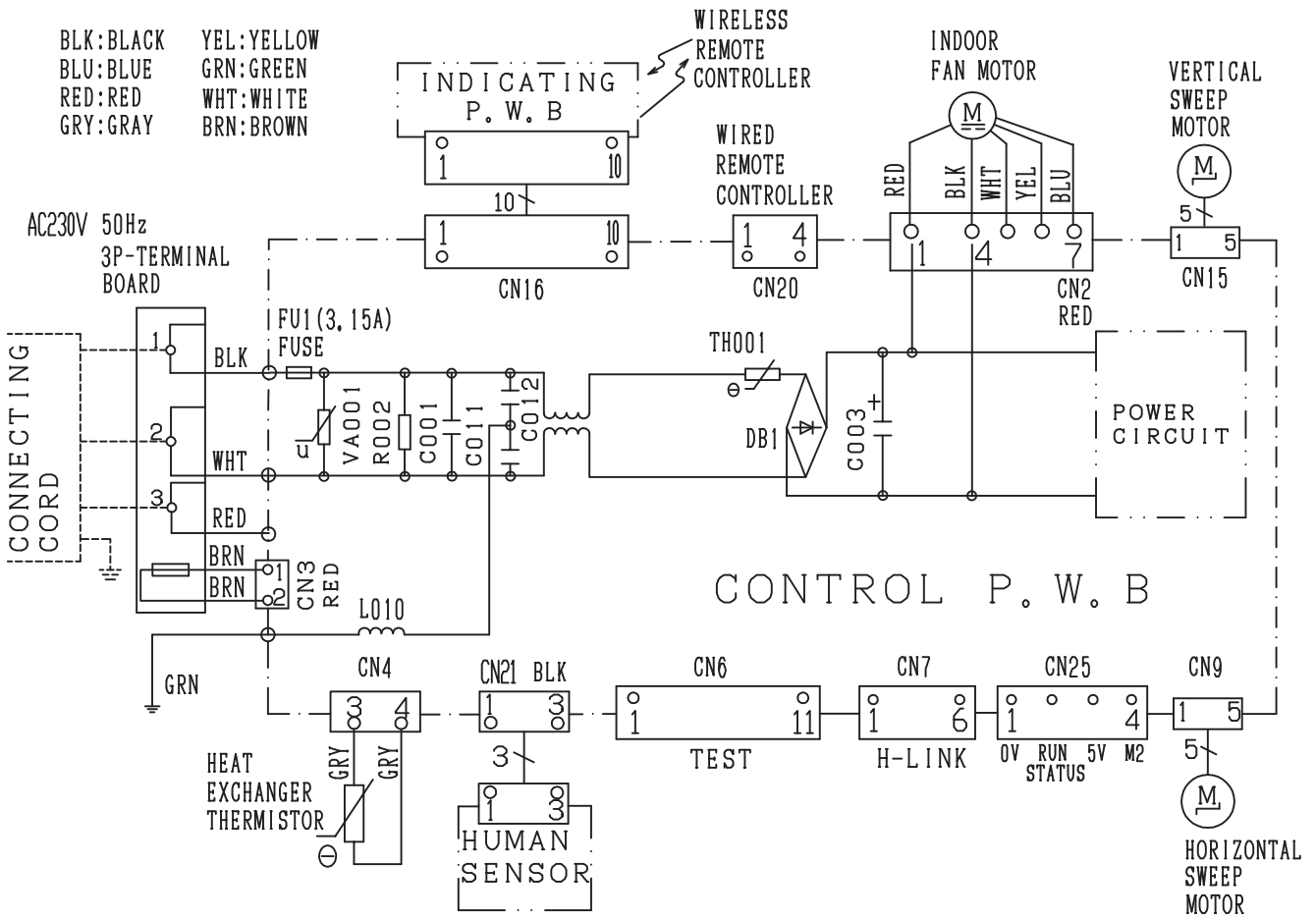

CAUTION ! HIGH VOLTAGE	TURN OFF THE POWER SOURCE DURING THE SERVICE WORK.
----------------------------------	---

7.2. RAC-18WPD/25WPD/35WPD

BLU:BLUE RED:RED
 BLK:BLACK WHT:WHITE
 BRN:BROWN YEL:YELLOW
 GRN:GREEN GRY:GRAY

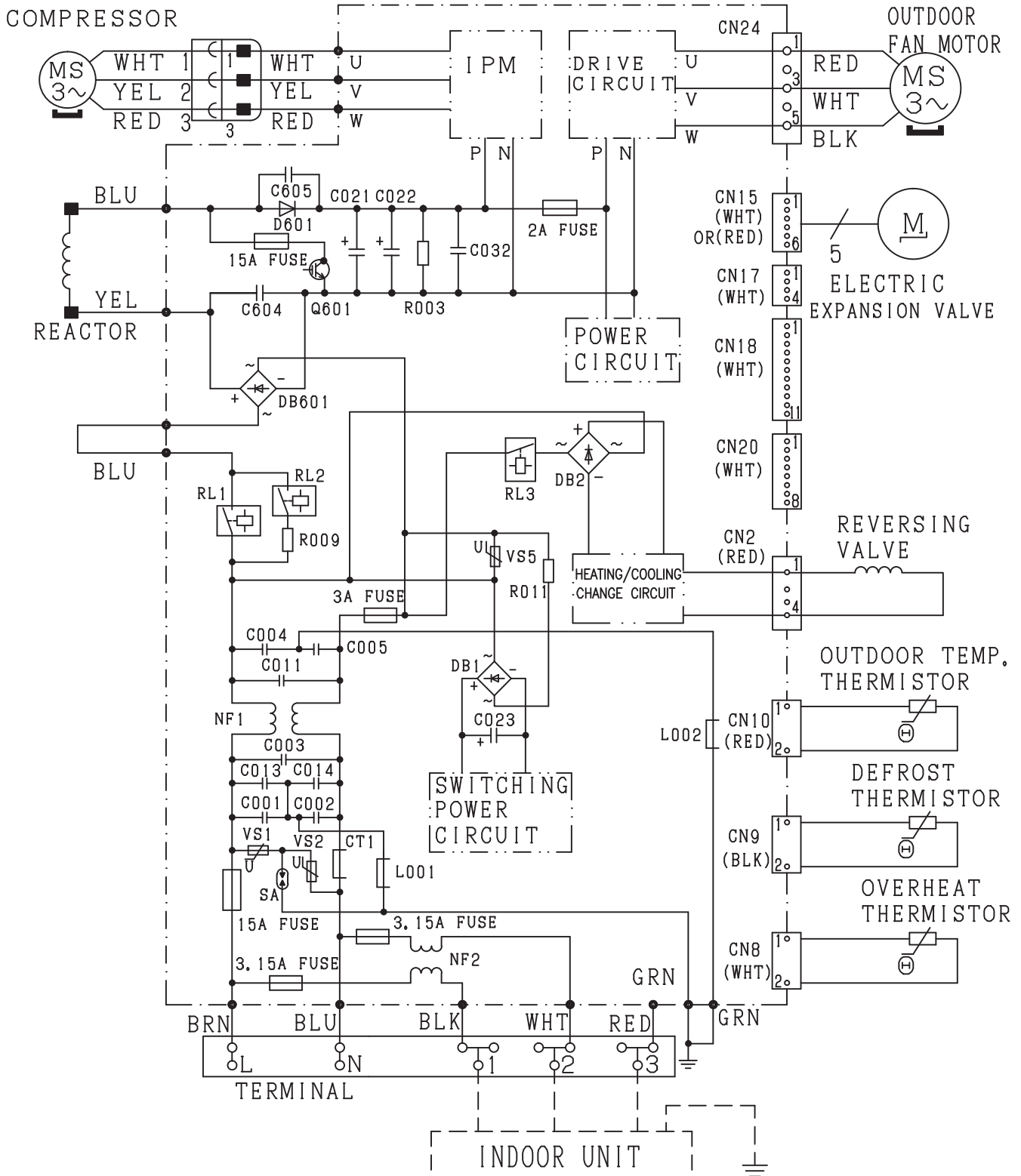

7.3. RAC-42WPD/50WPD

BLU:BLUE RED:RED
 BLK:BLACK WHT:WHITE
 BRN:BROWN YEL:YELLOW
 GRN:GREEN GRY:GRAY

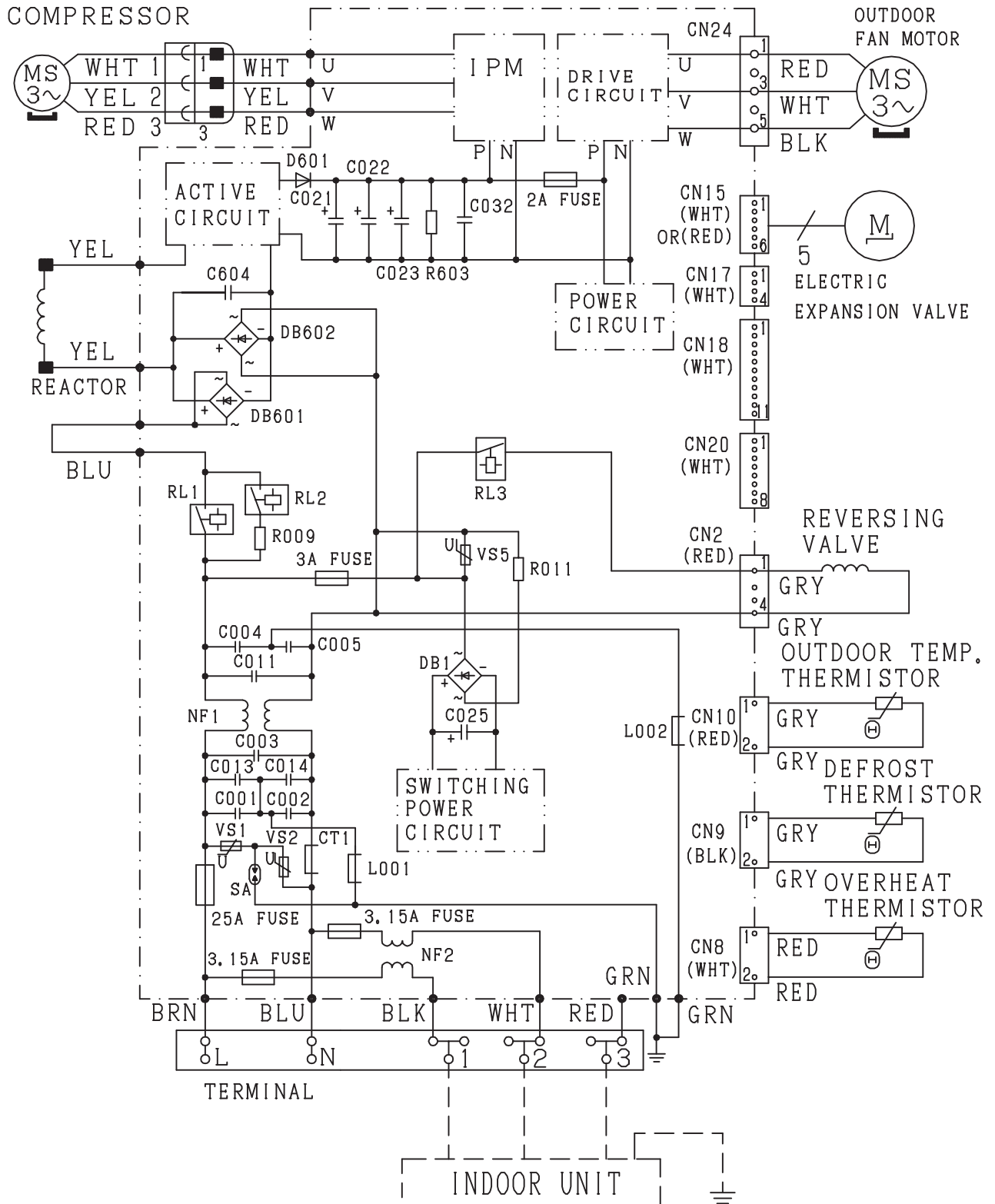

8 REFRIGERANT CYCLE

8.1. WALL TYPE: RAK-18RPD/RAC-18WPD、RAK-25RPD/RAC-25WPD、RAK-35RPD/RAC-35WPD

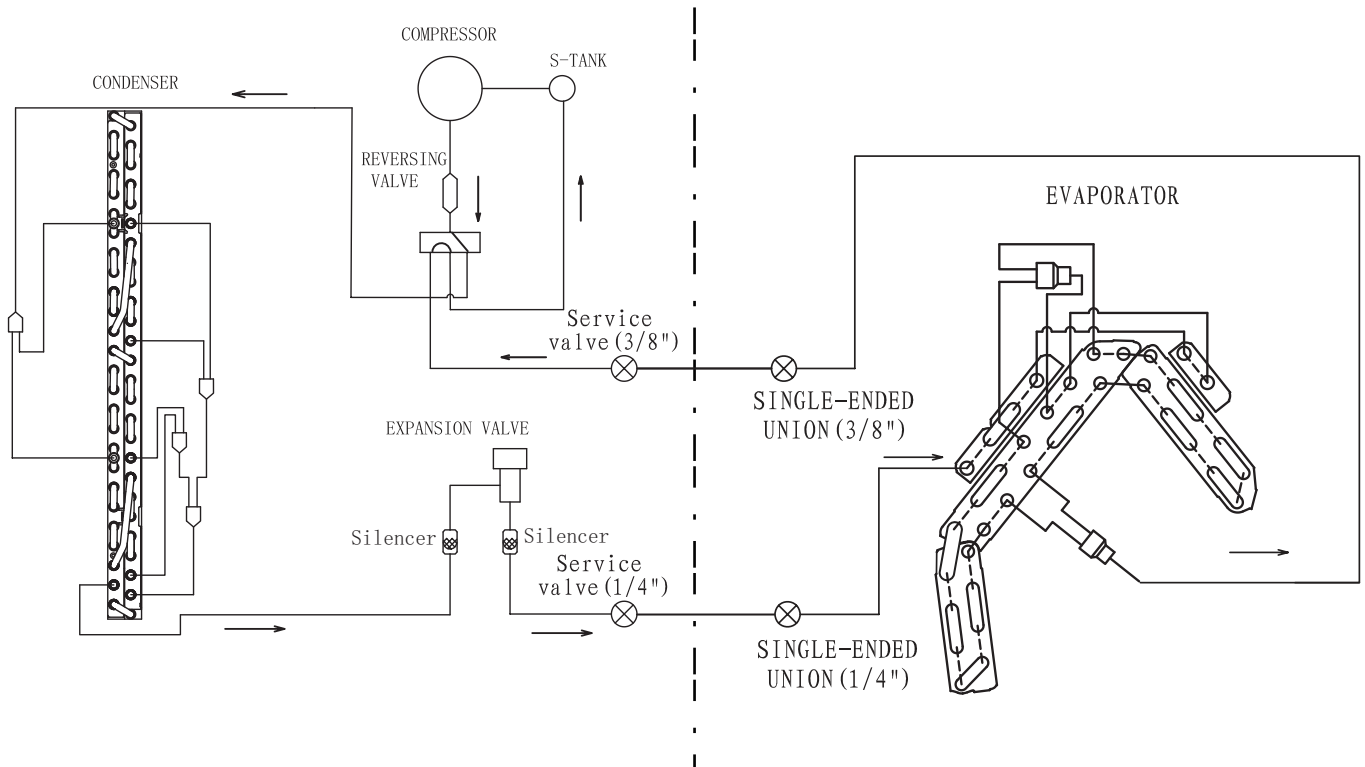

8.2. WALL TYPE: RAK-42RPD/RAC-42WPD、RAK-50RPD/RAC-50WPD

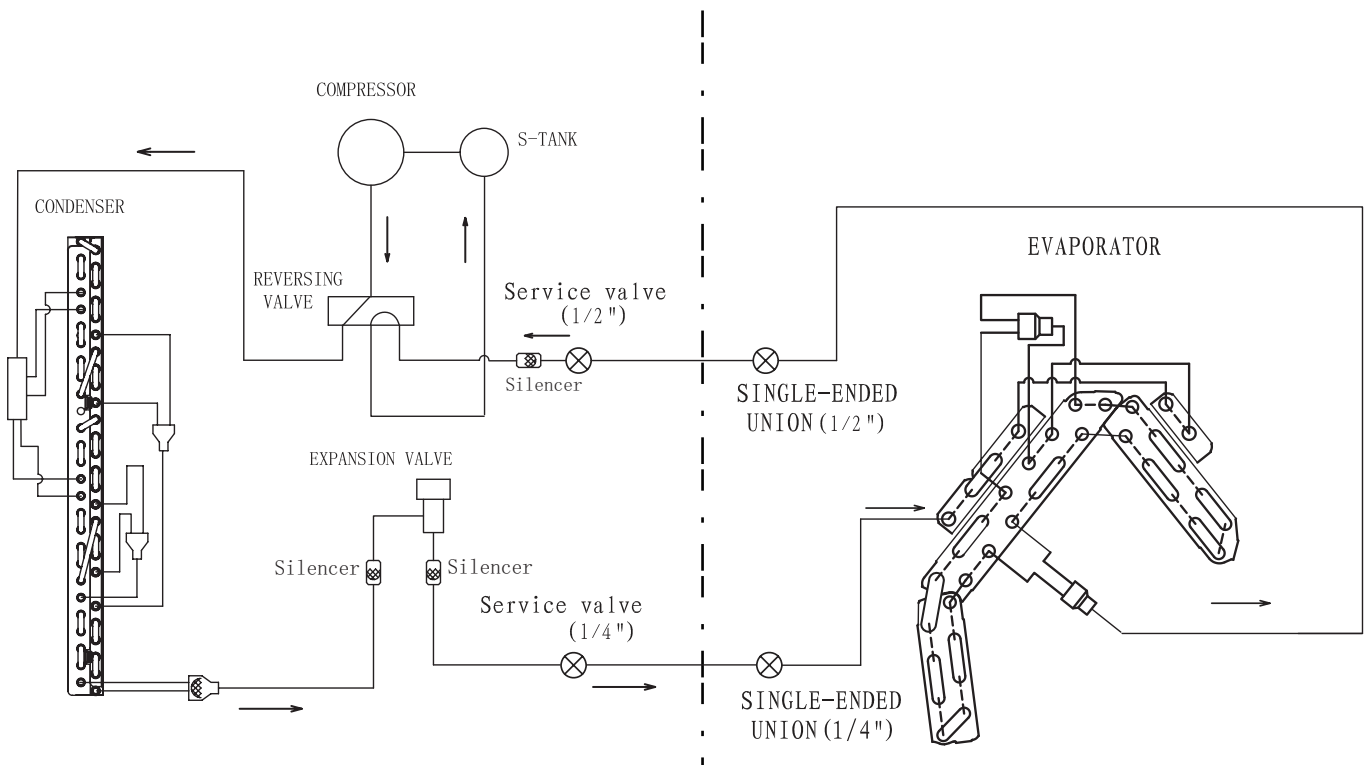

9 CONTROL AND FUNCTION

































9.1. WIRELESS REMOTE CONTROL FUNCTION

REMOTE CONTROLLER TYPE

RAR-6N1



RAK-18RPD
RAK-25RPD
RAK-35RPD
RAK-42RPD
RAK-50RPD

BUTTONS	FUNCTION
	MODE Selector Use this button to select the operations mode. Every time you press this button, the mode will change from  (AUTO) →  (HEAT) →  (DEHUMIDIFY) →  (COOL) and →  (FAN) cyclically.
	FAN SPEED Selector Button This determines the fan speed. Every time you press this button, the airflow rate will change from  (AUTO) →  (HIGH) →  (MED) →  (LOW) →  (SILENT) (This button allows selection of optimal or preferred fan speed for each operation mode).
	START/STOP button Press this button to start operation. Press it again to stop operation.
	ECO button Use this button to set the ECO mode.
	POWERFUL button Use this button to set the POWERFUL mode.
	SILENT button Use this button to set the SILENT mode.
	INFO button 1) Press this button to display temperature for 10 seconds. 2) Press this button to check monthly power consumption. 3) Press this button to receive the current calendar and clock.
	ECO SLEEP TIMER button Use this button to set the ECO sleep timer.
	AUTO SWING (Vertical) button Controls the angle of the horizontal air deflector.
	AUTO SWING (Horizontal) button Controls the angle of the vertical air deflector.
	LEAVE HOME button Prevent the room temperature from falling too much by setting temperature 10°C~16°C when no one is at home
	ONE TOUCH CLEAN button Drying indoor heat exchanger after cooling operation to prevent mildew.
WEEKLY TIMER buttons	
	ON/OFF TIMER button The device will turn on (off) and off (on) at the designated time.
	TIME button Press the button to set starting time of the program
	OK button Press the button to save the program. The button shall be pressed everytime after finishing a program setting.
	DELETE button 1) Press the button to delete the selected program. 2) Press the button for about 10 seconds by directing the remote controller towards the indoor unit while Mode A or B display blinks, programs for Mode A or B will be deleted both from the indoor unit and the remote controller after the beep sound from the indoor unit.
	DAY button Select the desired day of the week.
	PROGRAM NO. button Press this button to select a program number.
	CANCEL 1) Press the button to cancel the current setting process on the screen. 2) Press the button by directing the remote controller towards the indoor unit, then weekly timer setting will be canceled from indoor unit after the beep sound from the indoor unit. The program setting remains in the remote controller.
	SEND button Press the button for about 3 seconds by directing the remote controller towards the indoor unit after finishing the program setting. Timer lamp on the indoor unit will blink rapidly and after the beep sound from indoor unit, TIMER lamp will light up.
	CLOCK button Press the button to set calendar and clock.
	WEEKLY TIMER MODE button 1) Select Mode A or Mode B. 2 modes can be set and stored as a weekly timer. 2) By pressing the button longer than 3 seconds, program setting screen will appear.

9.2. AUTO CHANGEOVER

COOLING/HEATING mode is decided by the room temperature.

- A. COOLING/HEATING mode is decided during the **initial startup** of Automatic Operation
Initial startup of Automatic Operation means the following either condition:
- Unit start up in Automatic Operation
 - Automatic Operation mode is pressed while the unit is running in manual mode

Startup room temperature	COOL / HEAT
>= Remote controller setting temperature	Unit runs in COOLING mode
< Remote controller setting temperature	Unit runs in HEATING mode

- B. COOLING/HEATING mode is decided in **intervals after the initial startup** of Automatic Operation (also known as Auto Changeover function)

Intervals	Duration
1 st interval	10 minutes
2 nd interval	15 minutes
Subsequent interval	Every 55 minutes

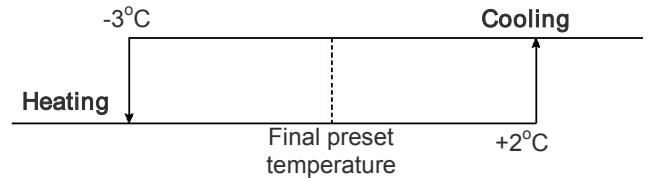

9.3. SHIFT VALUE

1. Press and hold \odot (START/STOP) button and \odot (ON) button.
2. Press RESET [RESET] button on the same time. Release RESET [RESET] button only, then release \odot (START/STOP) and \odot (ON) button once Screen 1 appears.



Screen 1

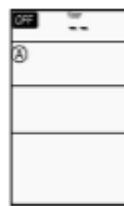

Screen 2

3. Press the MODE (MODE) button to display FAN fan mode (Screen 3).

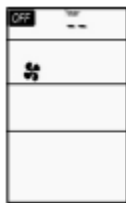

Screen 3

4. Press \odot (START/STOP) and Screen 4 appear.

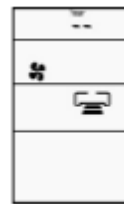

Screen 4

5. Select FAN (FAN SPEED) button to choose Heating Shift or Cooling Shift Mode (Screen 5).

By setting fan speed to HIGH H or MED M , it will go to Cooling Shift mode.
By setting fan speed to LOW L or SILENT S , it will go to Heating Shift mode.

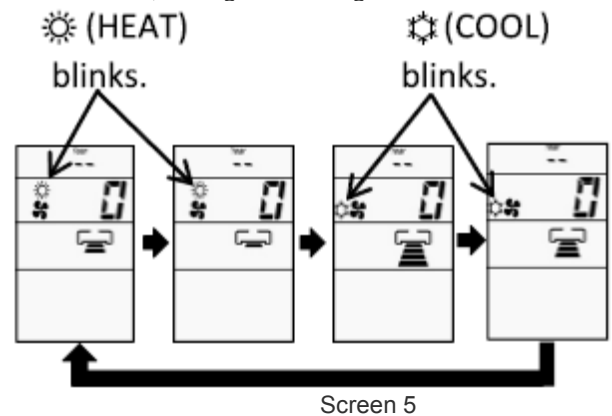

Screen 5

6. Press the Temperature button (V or ^) to adjust the shift value.

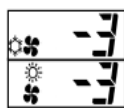

Decrease 3°C from the initial shift value setting.

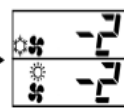

Decrease 2°C from the initial shift value setting.

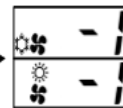

Decrease 1°C from the initial shift value setting.

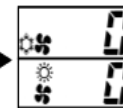

The initial shift value setting.

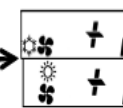

Increase 1°C from the initial shift value setting.



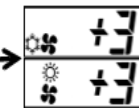

Increase 2°C from the initial shift value setting.









Increase 3°C from the initial shift value setting.

NOTE:

1. There are total of 7 shift values ranging from -3 to 3.
2. The displayed shift value,  (HEAT) and  (COOL) symbol on the remote controller display will be disappear after 10 seconds
3. The changed shift value will remain unchanged after turned off the power.
4. If "0" is displayed on the remote controller display, it indicates the shift value is now at the initial setting.

9.4. OPERATION LOCK

1. HEATING MODE

- a) Press and hold  (ECO) and  (POWERFUL) buttons, press  (RESET) button on the same time. Release  (RESET) button only when Screen 1 appear, then release  (ECO) button and  (POWERFUL) button.



Screen 1





- b) Wait until only Screen 2 appear.





Screen 2

- c) The heating mode operation is locked.
d) To unlock HEATING mode, repeat step (a). After all operations mode symbols displayed for 10 seconds, the operation mode symbol before cancellation will be display. The heating mode operation is unlocked.

2. COOLING AND DEHUMIDIFYING MODE

- a) Press and hold  (ECO) and  (SILENT) buttons for at least 5 seconds when the remote controller is OFF.
b) Wait until only  and  displayed on the screen. The cooling and dehumidifying modes operation is locked.
c) To unlock HEATING mode, repeat step (a). After all operations mode symbols displayed for 10 seconds, the operation mode symbol before cancellation will be display. The cooling and dehumidifying mode operation is unlocked.

9.5. SETTING THE PREVENTION OF MUTUAL INTERFERENCE

1. Please ensure the other indoor unit is OFF.
2. Press  (PROGRAM NO.) button,  (ON TIMER) button and  (RESET) button simultaneously. The remote controller will display Screen 1 and followed by Screen 2. The indoor unit beeps to indicate that it has just received the signal from remote controller.



Screen 1



Screen 2







NOTE:

1. If indoor unit still not receive the correct signal from the correct remote controller, setting shall be made again. By setting again for the 2nd time, the signal address will change from B to A, then repeat again for the 3rd time.

9.6. INTERMITTENT FAN SPEED SETTING

The intermittent fan control during thermo off in Heating Mode can be changed by the remote controller. (This procedure should be done only by service personnel.) It is possible to select from 3 patterns.

PROCEDURE

1. Press  [START/STOP] button,  [Mon-Sun] button and press  [RESET] button simultaneously. Release  [RESET] button only and make sure that all marks on the remote controller display are indicated, then release  [START/STOP] button and  [Mon-Sun] button. Remote controller now enters "Intermittent Fan Control Change Mode".

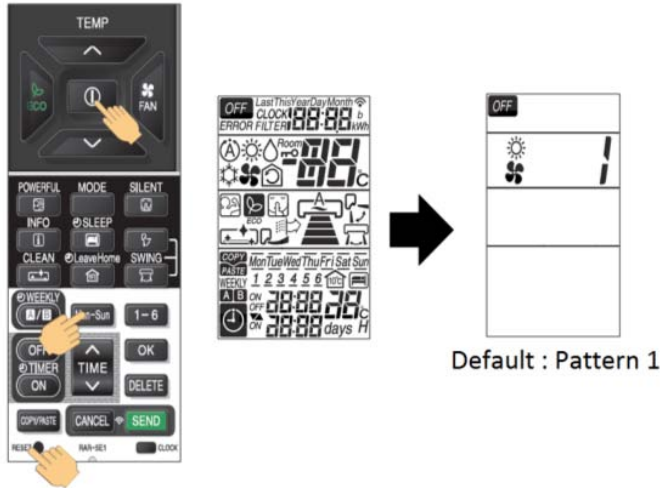

2. Press [ROOM TEMPERATURE setting] [\wedge (UP)]/[\vee (DOWN)] buttons. (The intermittent pattern changed with indoor unit beep sound.)

Transmission sign lights up with beep from indoor unit simultaneously.

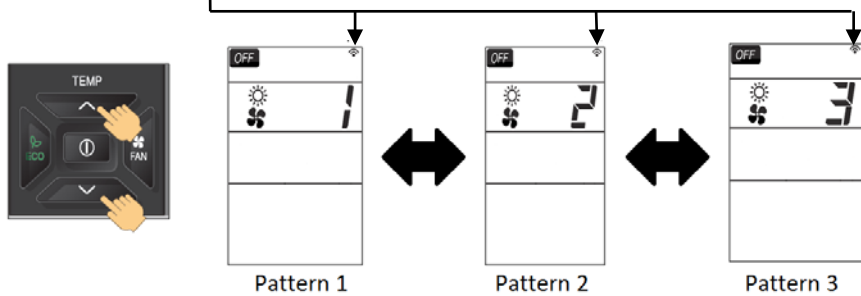

	Pattern 1	Pattern 2	Pattern 3
Single Model	Continuous	30sec ON / 210sec OFF repeatedly	50sec ON / 190sec OFF repeatedly
Multi Model	30sec ON / 210sec OFF repeatedly	50sec ON / 190sec OFF repeatedly	Continuous



NOTE :

- (1) The indication of the selected intermittent pattern will disappear after 10 seconds.
- (2) The selected intermittent pattern will remain unchanged after the unit is turned off.

9.7. FAN SPEED SETTING IN THERMO OFF IN COOLING

The fan speed in Cooling Mode during thermo off can be changed by the remote controller.
(This procedure shall be implemented strictly by service personnel only.)
It is possible to return it to the default setting.

PROCEDURE

Press  [POWERFUL] button and  [TIME ^ (UP)] button simultaneously for about 5 seconds when the remote controller is OFF.

Transmission sign lights up with beep from indoor unit simultaneously.

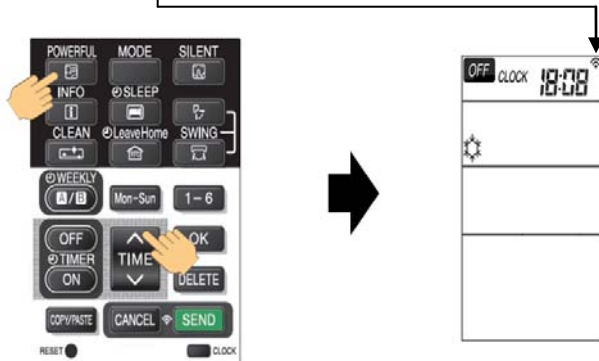



Beep sound pattern :
 1) Default setting : Short beep
 2) Changed setting : Double beep

	Fan speed during thermo off
Default Setting	Ultra low
Changed Setting	Set fan speed (When auto fan speed is set, the fan speed is low)

NOTE :

- (1) The selected fan speed will remain unchanged after the unit is turned off.
- (2) If Timer reservation has been set, it will be canceled.
- (3) During time setting and timer setting, this operation cannot be set.

9.8. ERROR CODE INFORMATION

1. In case failure occurs to the air conditioner, by pressing  (INFO) button, an error code will be displayed.
2. Direct the remote controller towards the receiver of indoor unit (within 2 meters in from of indoor unit) and press  (INFO) button.
3. Wait for 2 seconds for signal transmission and the error code will be displayed.

	TIMER LAMP BLINKING	LED301 BLINKING	CODE	MEANING
INDOOR	-	-	000 00	Normal
	1 time	-	001 00	Refrigerant cycle fault
	2 times	-	-	Outdoor unit is under forced operation
	3 times	9 times	003 00	Communication error between indoor and outdoor units
	9 times	-	009 00	Indoor thermistor
	10 times	-	010 00	Abnormal rotating numbers
	12 times	-	012 00	Communication error between indoor and outdoor units
	13 times	-	013 00	IC401 data reading error
OUTDOOR	4 times	2 times	002 01	Peak current cut
	4 times	3 times	003 01	Compressor abnormal low speed rotation
	4 times	4 times	004 01	Compressor switching failure
	4 times	5 times	005 01	Overload lower limit cut
	4 times	6 times	006 01	OH thermistor temperature rise
	4 times	7 times	007 01	Abnormal outdoor thermistor
	4 times	9 times	009 01	Communication error
	4 times	10 times	010 01	Abnormal power source
	4 times	11 times	011 01	Fan stop for strong wind
	4 times	12 times	012 01	Fan motor fault
	4 times	13 times	013 01	EEPROM reading error
	4 times	14 times	014 01	Active converter defective
	4 times	15 times	015 01	Abnormal PWB circuit
	4 times	16 times	016 01	Hign load stop

9.9. ADDITIONAL FUNCTION VIA DIP-SWITCH SETTINGS

A new DIP Switch is available on the PWBs of the indoor unit that provide additional functions via the settings on the switches.

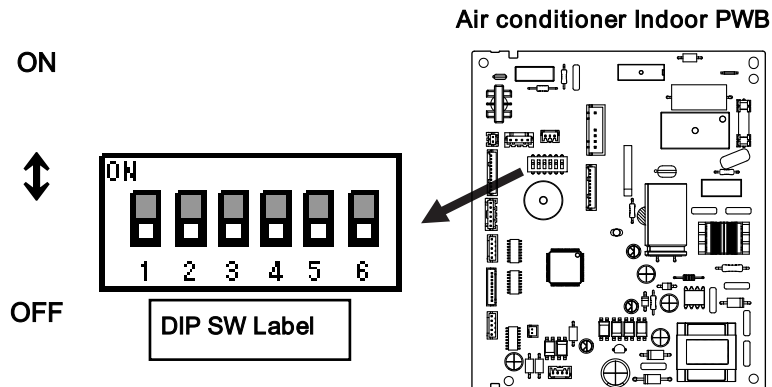

SW No.	I T E M	F U N C T I O N							
1	AUTO RESTART	OFF*	ENABLE	ON	DISABLE				
2	CARD KEY MODE	OFF*	DISABLE	ON	ENABLE				
3	CARD KEY LOGIC SELECT	OFF*	INPUT HIGH ACTIVE	ON	INPUT LOW ACTIVE				
4	HEATING/COOLING ONLY MODE SELECT	OFF*	HEATING & COOLING	OFF	HEATING ONLY	ON	COOLING ONLY	ON	HEATING & COOLING
5	HEATING/COOLING ONLY MODE SELECT	OFF*		ON		OFF		ON	
6	REMOCON ID SELECT	OFF*	SELECT ID : A	ON	SELECT ID : B				

NOTE:

* Marking is position of shipping [FACTORY default setting]

9.9.1. AUTO RESTART FUNCTION

The AUTO RESTART function can be enabled or disabled by setting Pin No. 1 on the DIP SWITCH above to the ON or OFF position accordingly.





















9.9.2. HEATING/COOLING ONLY MODEL SELECTION

When this function is enabled, the operation mode could be locked to either Heating Only (Heating or Fan) or Cooling Only (Cooling, Fan or Dehumidifying) by setting the Pin No. 4 and 5 accordingly.





LOCKED MODE	REMARKS
HEATING ONLY	Unit will not enter into Cooling mode although cooling mode is selected using the remote controller.
COOLING ONLY	Unit will not enter into Heating mode although heating mode is selected using the remote controller.

10 OPTION LIST



10.1. WIRED REMOTE CONTROL – SPX-RCDB



 <p>RAR-5G2 (SPX-RCDB)</p>	BUTTONS	FUNCTION
		MODE Selector Use this button to select the operating mode. Every time you press this button, the mode will change from  (AUTO) →  (HEAT) →  (DEHUMIDIFY) →  (COOL) and →  (FAN) cyclically.
		FAN SPEED Selector Button This determines the fan speed. Every time you press this button, the airflow rate will change from  (AUTO) →  (HIGH) →  (MED) →  (LOW) →  (SILENT) (This button allows selection of optimal or preferred fan speed for each operation mode).
		ON/OFF button Press this button to start operation. Press it again to stop operation.
		SLEEP button Use this button to set the SLEEP timer.
		SET button Timer setting reservation.
		OFF button Select the turn OFF timer.
		ON button Select the turn ON timer.
		CANCEL button Cancel timer reservation.
		AUTO SWING (Vertical) button Controls the angle of the horizontal air deflector.
		ROOM TEMPERATURE setting button Value will change quicke when keep pressing.

10.1.1. SHIFT VALUE

1. Press and hold  (ON/OFF) button and  (ON TIMER) button at the same time while giving a single press on the RESET button until remote controller now enter 'Shift value change mode'.
2. Press  (ON/OFF) button so that the display indicates  (FAN) speed.
3. Select  (FAN SPEED) button to choose Heating Shift or Cooling Shift Mode.

By setting fan speed to HIGH  or MED  , it will go to Cooling Shift mode.

By setting fan speed to LOW  or SILENT  , it will go to Heating Shift mode.



4. Press  (ROOM TEMPERATURE) button to change the shift value (-3°C ~ 0 ~ 3°C).
5. Press  (ON/OFF) button to end 'Shift value setting mode'.

NOTE:

1. There are total of 7 shift values ranging from -3 to 3.
2. The changed shift value will remain unchanged after turned off the power.

10.1.2. ERROR CODE INFORMATION

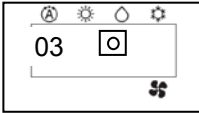
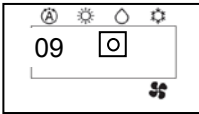
1. In case failure occurs to the air conditioner, the error code will constantly appear on the wired remote controller display.

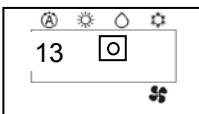
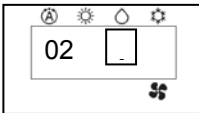
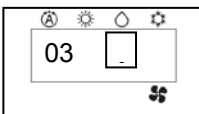
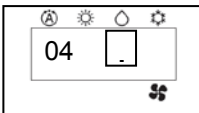
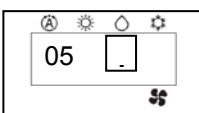
	TIMER LAMP BLINKING	LD301 BLINKING	CODE	MEANING
INDOOR	-	-	-	Normal
	1 time	-		Refrigerant cycle fault
	2 times	-	-	Outdoor unit is under forced operation
	3 times	9 times		Communication error between indoor and outdoor units
	9 times	-		Indoor thermistor defective
	10 times	-		Abnormal rotating numbers
	12 times	-		Communication error between indoor and outdoor units
	13 times	-		IC401 data reading error
OUTDOOR	4 times	2 times		Peak current cut
	4 times	3 times		Compressor abnormal low speed rotation
	4 times	4 times		Compressor switching failure
	4 times	5 times		Overload lower limit cut

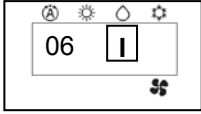
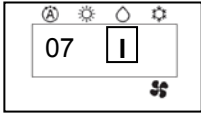
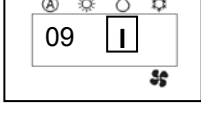
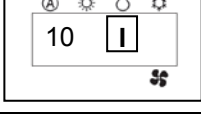
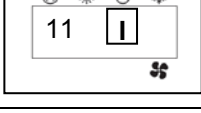
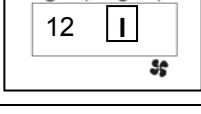
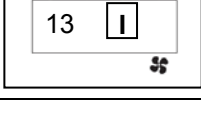
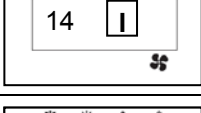
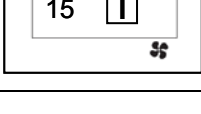
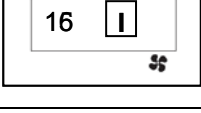
	TIMER LAMP BLINKING	LD301 BLINKING	CODE	MEANING
OUTDOOR	4 times	6 times		OH thermistor temperature rise
	4 times	7 times		Abnormal outdoor thermistor
	4 times	9 times		Communication error
	4 times	10 times		Abnormal power source
	4 times	11 times		Fan stop for strong wind
	4 times	12 times		Fan motor fault
	4 times	13 times		EEPROM reading error
	4 times	14 times		Active converter defective
	4 times	15 times		Abnormal PWB circuit
	4 times	16 times		High load stop

10.2. H-LINK ADAPTOR – PSC 6RAD

10.2.1. SAFETY SUMMARY

DANGER:

- DO NOT pour water into the remote control switch (hereafter called "controller"). This product is equipped with electrical parts. This will cause serious electrical shock.

WARNING:

- DO NOT perform installation work and electrical wiring connection by yourself. Contact your distributor or dealer of HITACHI and ask them for installation work and electrical wiring by service person. The specified cable should be used to connect (i) room air conditioner and adaptor, and (ii) controller and adaptor.



CAUTION:



- DO NOT install the indoor unit, outdoor unit, controller and cable as such places as:
 - where there is oil vapor and dispersion of oil
 - where there is sulfuric environment (near the hot springs)
 - where there is a flammable gas
 - where there is salty environment (near the sea)
- DO NOT install the indoor unit, outdoor unit, controller and cable within approximately 3 meters from strong electromagnetic wave radiators, such as medical equipment. In case that the controller is installed in a place where there is electromagnetic wave direct-radiation, shield the controller and cables by covering with the steel box and running the cable through the metal conduit tube.
- In case that there is electric noise at the power source for the indoor unit, provide a noise filter.

10.2.2. INSTALLATION WORK

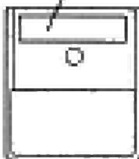
■ Before installation

Check the contents and the number of the accessories in the packing.

Adaptor	 With two 1.8m cables
1 piece of cover for hiding the covering	 Attached 2 sided tapes
Two-sided tape for attaching to Adaptor	 110x40x3mm

2 connectors for H-Link connection		
2 tapping screws for attaching to wall		φ3.0 x 10mm
2 screws for attaching to wooden wall		φ3.1 x 16mm

- 1) RAC adaptor can be installed to the wall as well as on the air conditioner itself
- 2) Install RAC adaptor in the vertical surface as shown below.

Upper side

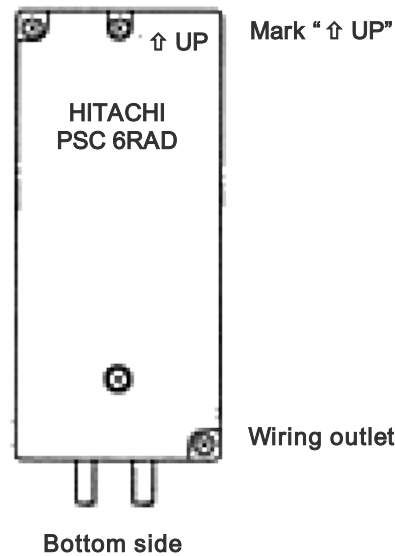

Bottom side

- 3) Installation procedure
 - a) When installing to the wall.
 - i) Fix the adaptor with 2 screws. Tapping screw is for metal surface, and other screw is for wooden surface.

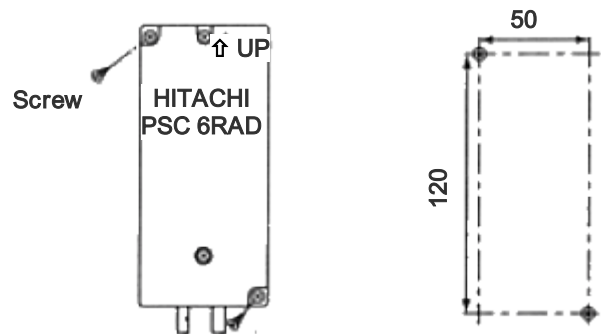

- ii) When using the cover

It can be installed at the right and left side of room air conditioner. Fix the cover and RAC adaptor with the two-sided tape (accessory).

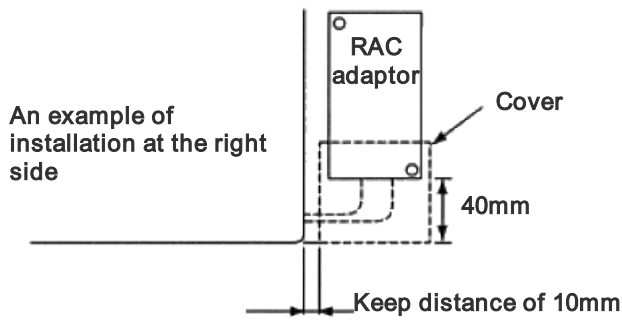

An example of installation at the right side

- b) When installing on the room air-conditioner
In case that it cannot be installed to the wall due to the space or material problem, install the RAC adaptor with the two-sided tape (accessory) on the room air-conditioner.
- Confirm if the piping cover of the unit can be removed when performing the service maintenance, and then fix the RAC adaptor in the side of room air-conditioner with two-sided tape. (Available at the right as well as left side)
 - Clean the surface to be installed with a dry cloth.

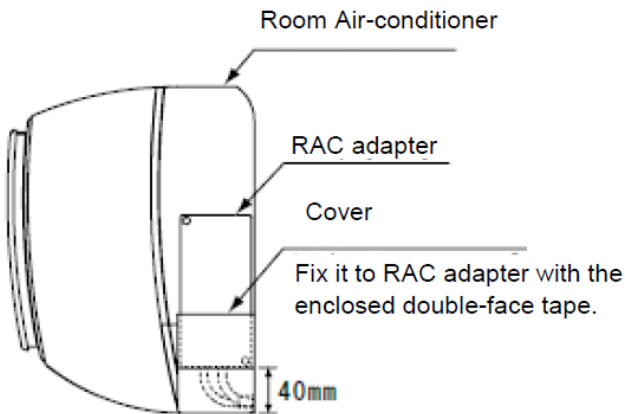

NOTE:

- Consider the following points since the adhesiveness changes according to the environmental conditions (temperature, humidity etc)
- The adhesiveness is decreased when there is humidity or oil.
- Warm the adhesive part and installation place of the two-sided tape to avoid the decrease of the adhesiveness in case the ambient temperature is low.
- DO NOT touch the adhesive part by fingers nor re-attach it many times. The adhesiveness has decreased and the RAC adaptor may fall off.
- DO NOT apply any force within 24 hours after installation.

10.2.3. ELECTRICAL WIRING

■ System configuration

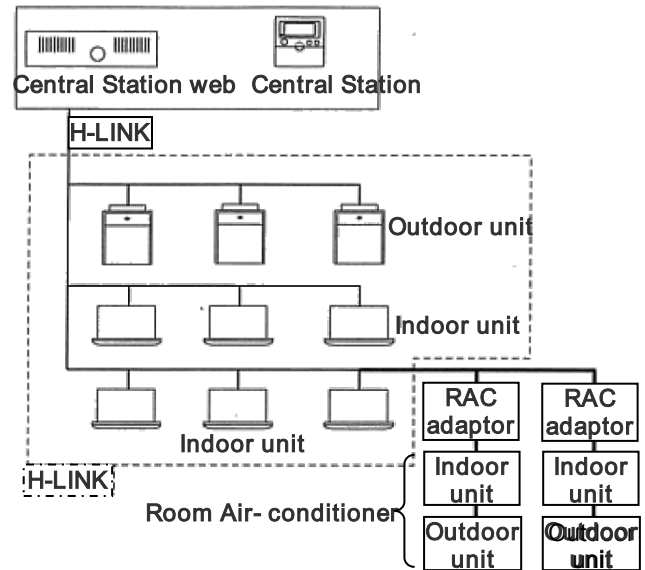

CAUTION:

- Turn OFF the power supply of the room air-conditioner of the central control device when performing the wiring work
- DO NOT run all the H-LINK cable or power supply cable along the other signal cable, or malfunction may occur due to the noise, etc. If it is required to run along the other transmission cable, separate the cable more than 30cm, or run the cable through the metal tube and earth the tube.
- Follow local codes and regulations when performing electrical wiring and earth wiring.
- Transmissions cable used in H-LINK shall be 2 cores cable (0.7mm^2 to 1.25mm^2 for model: VCTF, VCT, CVV, MVVX, CVVX, VVR, VVF) or 2 cores twisted pair cable (model: KPEV, KPEV-Spec). Total length of cable shall be below 1000mm.
- DO NOT use wire with more than 3 cores.

■ Internal components and Wiring connections

Check the contents and the number of the accessories in the packing.

- Access
Open the cover by removing the ① and ② screws.



- Wiring Connection
Connection with Room Air-Conditioner
 - Remove the front cover of the room air-conditioner and the cover of electrical box.
 - The cable attached with the connector of the RAC adaptor shall be connected with the connector of indoor PCB

- iii) Install the electrical box cover paying attention not to clamp the cable. Read the installation manual of each room air-conditioner for confirming how to connect and how to assemble the cable of the RAC adaptor.

CAUTION:

- Disconnect the power plug before performing this work
- Turn OFF the break power source in case the power is supplied from the outdoor unit.
- Connection of Transmission Cable
H-LINK transmission cable connecting to RAC adaptor shall be connected to H-LINK.

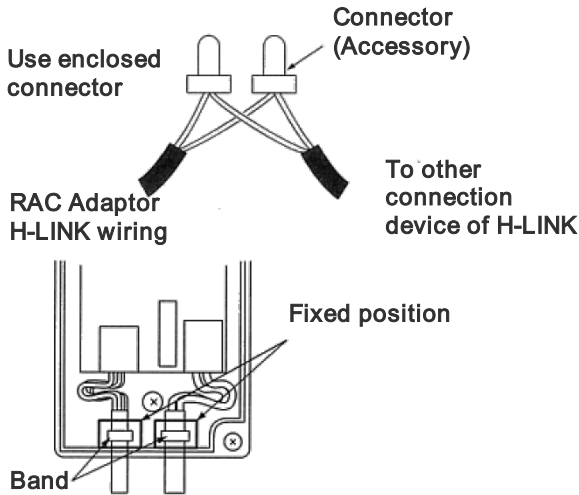

CAUTION:

- DO NOT connect incorrect wiring. It may cause the failure of the RAC Adaptor. Especially pay attention not to apply high voltage e.g. AC400/230V.
- DO NOT perform the wiring work while power to the central station or the RAC Adaptor is still being supplied. It may cause malfunction. Turn OFF devices when performing the wiring work.
- The RAC Adaptor side cable should not overload to the connector.
- DO NOT clamp the cable when attaching the RAC adaptor cover.
- Band should not be loose and in fixed position.

10.2.4. DIP SWITCH SETTING

- 1) Switch OFF the power of room air conditioner before setting the DIP switch. If the power is ON, the settings are INVALID.
- 2) The position of the DIP switch is shown below.

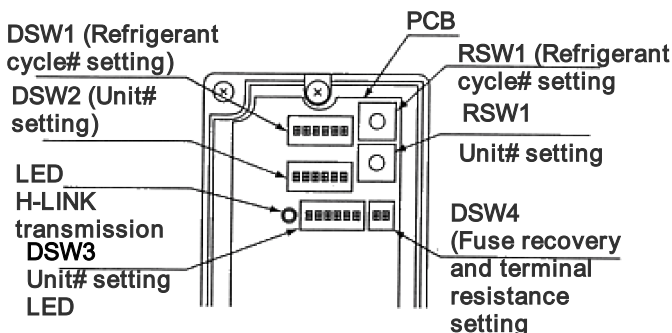

CAUTION:

- DO NOT turn ON various pins of DSW1 and DSW2

- 3) Set the refrigerant cycle# by RSW1 and DSW1

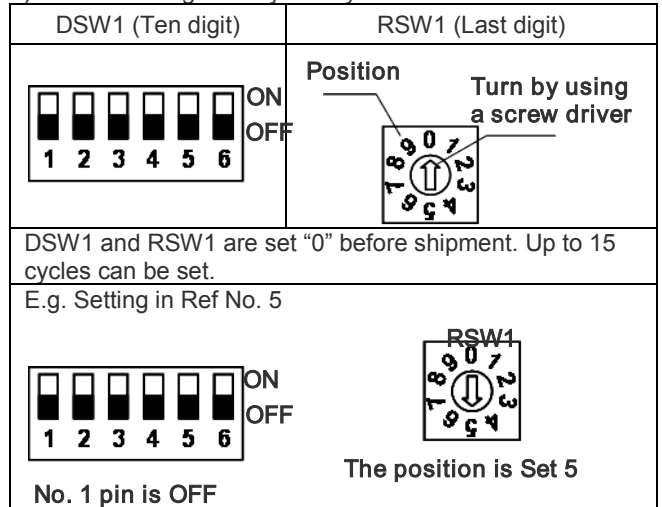

- 4) Set the unit No. by RSW2 and DSW2

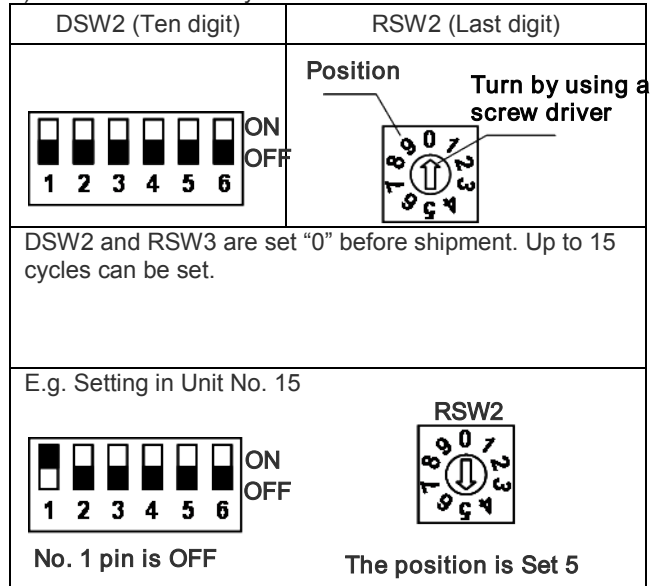

- 5) Slave unit.

In case of setting various RAC adaptors in the same refrigerant cycle, set the RAC adaptor with smallest Unit# as a master unit. In case of setting only one RAC adaptor in a refrigerant system, this adaptor should be a master unit. Set this procedure by DSW3.

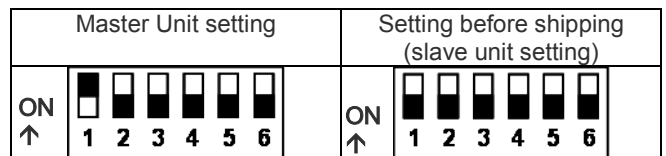

●: Master Unit setting

○: Setting before Shipping (Slave Unit setting)

		Indoor Unit#							
		0	1	2	3	4	5	6	7
Refrigerant Unit#	0	●	○	○	○	○			
	1			●	○	○			
	2				●	○	○	○	○
	3		●						
	4								

CAUTION:

– DO NOT set various main adaptors in the same refrigerant cycle.

- 6) Procedure when applying 200V voltage to H-LINK wiring incorrectly.

In case of applying 200V voltage to H-LINK wiring incorrectly, the fuse installed in a transmission circuit on PCB will blow out. In this case, reconnect the wiring correctly and turn ON No. 2 pin of DSW4 on PCB. The transmission circuit can be recovered. (If applying this error again, the transmission circuit can not be recovered)

PCB



Turn ON No.2 pin of DSW4

- 7) Terminating resistance is set in whole H-LINK system.
 - a) If H-LINK connecting devices like package air-conditioner are connected besides the RAC Adaptor, set the terminating resistance by those connecting devices. The terminating resistance should be set ON in only one position in whole H-LINK system.
 - b) In case that H-LINK is connected only by the RAC adaptor, set the terminating resistance by the RAC adaptor. The terminating resistance should be set ON in only one position in whole H-LINK system.

PCB

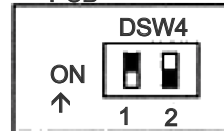

Turn ON No.1 pin of DSW4

10.2.5. TEST RUN

Test run should be performed in the following after finishing the installation, wiring and setting. Refer to the installation manuals enclosed with the control system equipment.

- 1) Confirmation of RAC Adaptor Connection
 - Confirm if the RAC adaptor connection is recognized in the control system equipments. In case that it is not confirmed, check the transmission cable, refrigerant cycle #, indoor unit #, terminal resistance setting etc.
- 2) Registration
 - Confirm if the RAC adaptor connection is recognized.
- 3) Confirmation of RUN/STOP Operation.
 - Confirm if the room air-conditioner operate correctly by RUN/STOP from the central control system equipments. Check also if the room air-conditioner operation changes correctly by each setting.

10.3. DRY CONTACT (SPX-WDC3) APPLICATION (USING DIP SWITCH)

The dry contact system enables the operation of the air conditioner indoor unit to be controlled by using external dry contacts (with non voltage) such as card-key controller or window for facilities such as hotels.

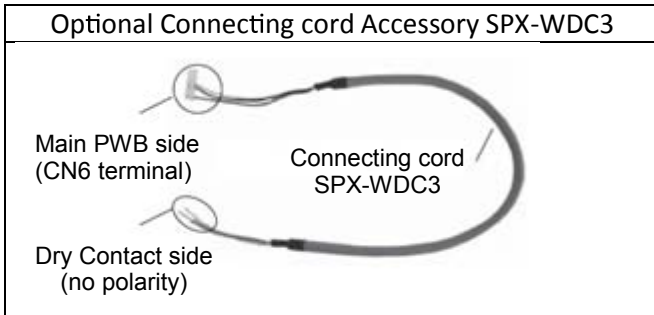

Note:

- 1) AUTO RESTART function set to "Enable" is needed (set pin#1 on the DIP SWITCH SW501 above to OFF position).
- 2) DRY CONTACT function is "Enable" by set pin No. 2 of the DIP SWITCH (DSW1) to ON position.
- 3) Select the proper setting for DRY CONTACT LOGIC INPUT pin No. 3 on DIP SWITCH (DSW1)
 - i) Set to OFF position (Hi Input) if the type of Dry Contact switch to be used (for the CARD KEY UNIT or Window) is of contact type a (Normally Open Type) as shown in below diagram.
 - ii) Set to ON position (Lo Input) if the type of Dry contact switch to be used (for the CARD KEY UNIT or Window) is of contact type b (Normally Close Type) as shown in below diagram.

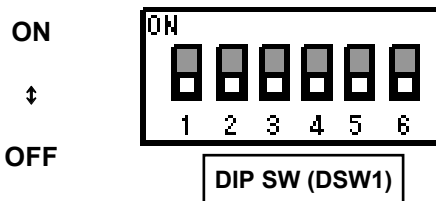

Pin No.	Function	Switch Position / Setting			
		OFF	Disable	ON	Enable
2	DRY CONTACT function	OFF	Disable	ON	Enable
3	DRY CONTACT Input Logic	OFF	HI Input Active	ON	LO Input Active

- Please decide the type of dry contact you will be using and set the position of the DIP Switch No. 2 and 3 accordingly

[1] CHECK DRY CONTACT OF CARD KEY UNIT

	AIR CONDITIONER Standby	AIR CONDITIONER Operating
	CARD KEY (Door Switch)	REMOVE
Contact type a	OPEN 	CLOSE
Contact type b	CLOSE 	OPEN

[2] SET THE POSITION OF DIP SWITCH

POSITION CONDITION OF DIP SWITCH	
<p>INITIAL CONDITION (CARD KEY NO USE) No.2 : OFF No.3 : OFF</p>	
<p>HI Input Active No.2 : ON No.3 : OFF</p>	
<p>LO Input Active No.2 : ON No.3 : ON</p>	

After all connection has been done as below diagram, ON the breaker and push ON button of wireless remote controller or wired remote controller to operate the air conditioner unit.

- When the CARD KEY is in insert condition, the air conditioner operation is allowable by remote controller.
- When the dry contact switch on the Card Key Unit is open (refer to diagram below for contact type a), the unit stops to operate (it takes 10 seconds to stop the unit operation after the dry contact switch on the card key turns off) and vice versa.
- When the card key is removed from the Card Key Unit, the wireless remote controller cannot be used.
- When the card key is removed from the Card Key Unit, the wired remote controller LCD display is activated; however it has no control over the unit.
- The suitable accessory Connecting Cord (accessory code#: SPX-WDC3) need to be used to connect the Card Key Unit's dry contact switch to the connector on the control board of the indoor unit. Please refer to Table 1 to select suitable accessory code# for the concerning indoor model.

Example of wiring connection to Card Key Unit will be as below (reference only)

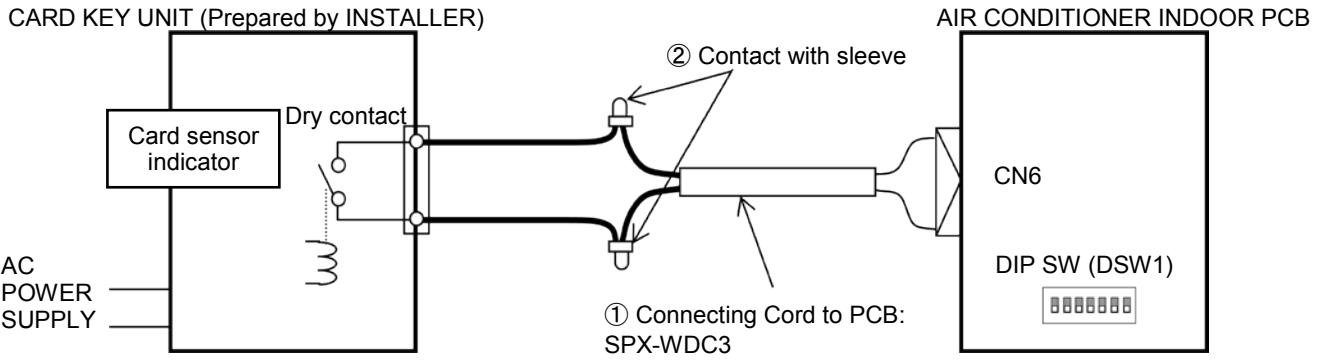

• CONNECTION EXAMPLE

i. Pin No. 3 of DIP SWITCH is set to OFF position (HI Input Active) for Dry Contact Type a

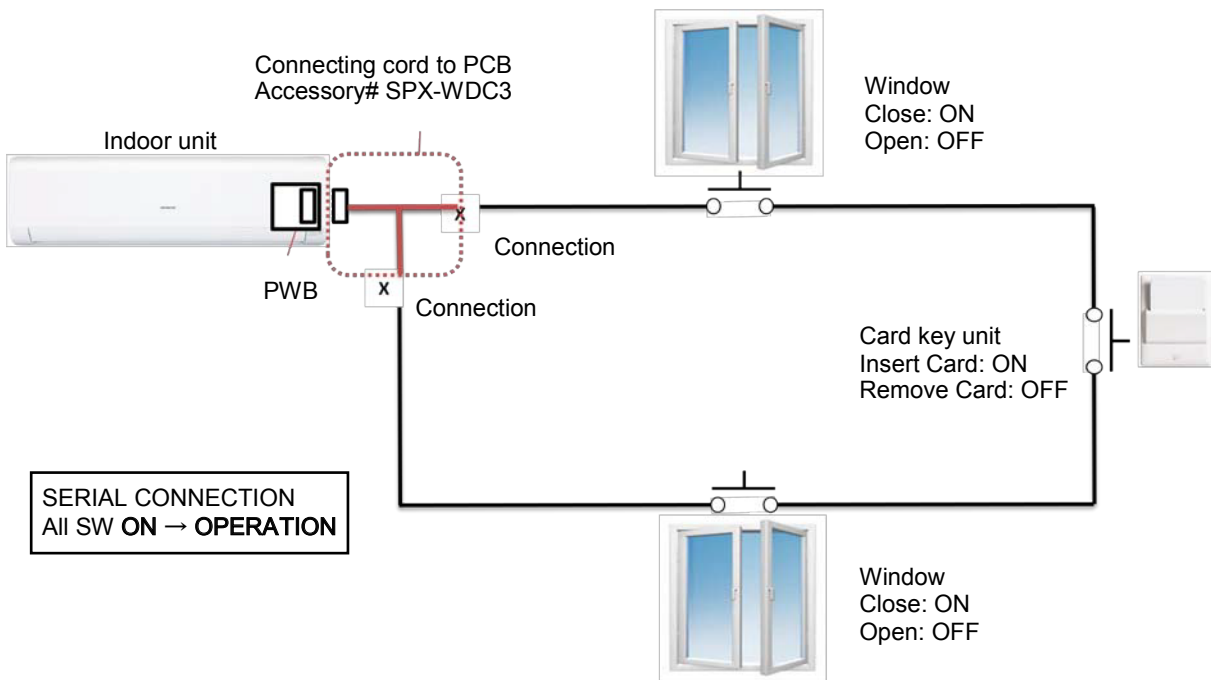

ii. Pin No. 3 of DIP SWITCH is set to ON position (LO Input Active) for Dry Contact Type b

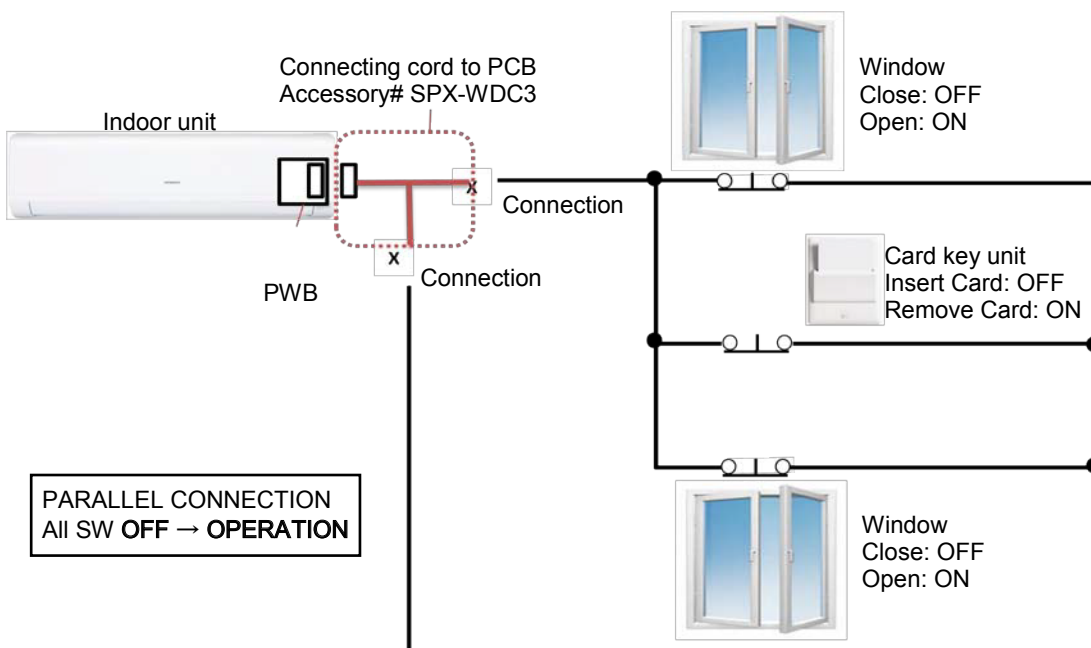

Please refer to the actual manual supplied with the optional connecting cords SPX-WDC3 for more details.

10.4. DISTRIBUTOR – SPX-DST1

The optional distributor is to be used together with the wired remote controller when there is a need to centralize the control of multiple indoor units using only a single wired remote controller.

A single distributor could be connected further to 3 separate distributors so that up to 13 units of indoor could be controlled by a single wired remote controller.

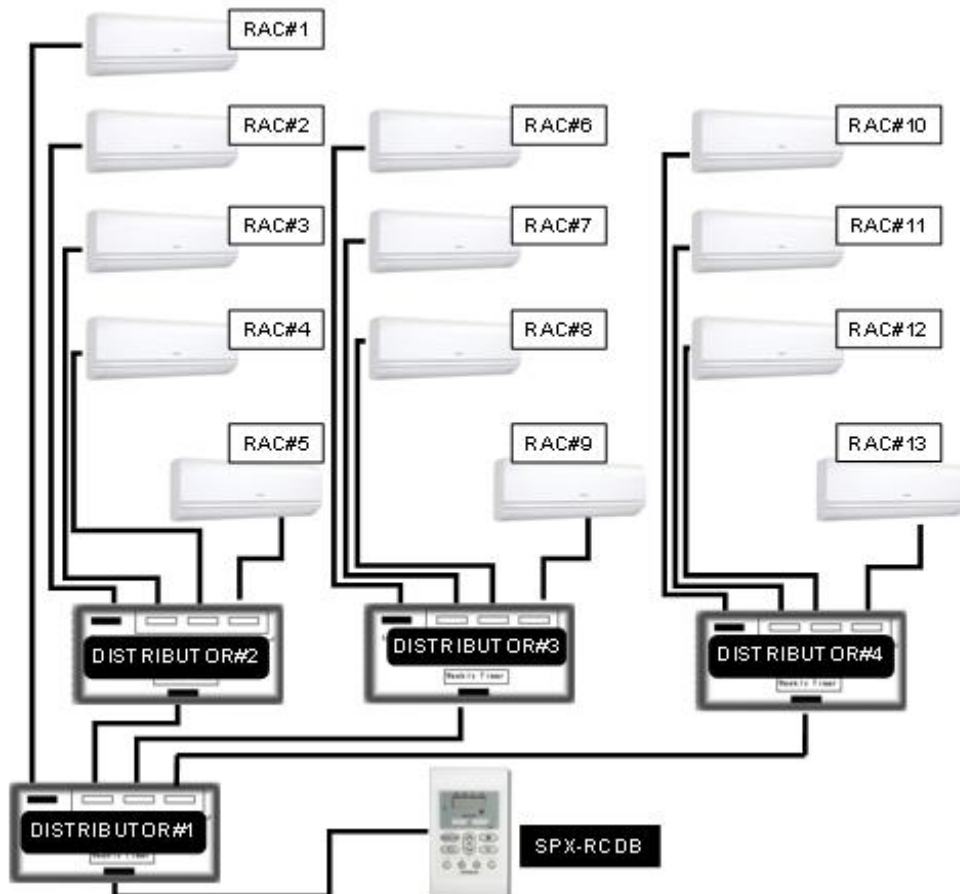
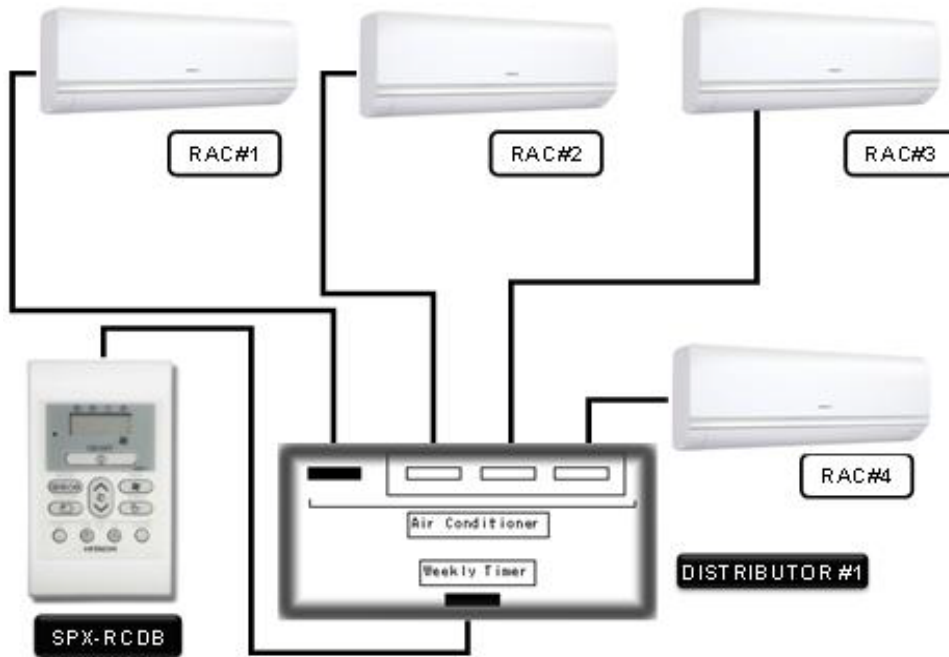

HITACHI

TC-ERP-Model (2018.01)

INDOOR

RAK-18RPD

RAK-25RPD

RAK-35RPD

RAK-42RPD

RAK-50RPD

OUTDOOR

RAC-18WPD

RAC-25WPD

RAC-35WPD

RAC-42WPD

RAC-50WPD