

7.1.2 Split system - Indoor unit

7.1.2.1 YUTAKI S

◆ RWM-(2.0-3.0)NE(-W)

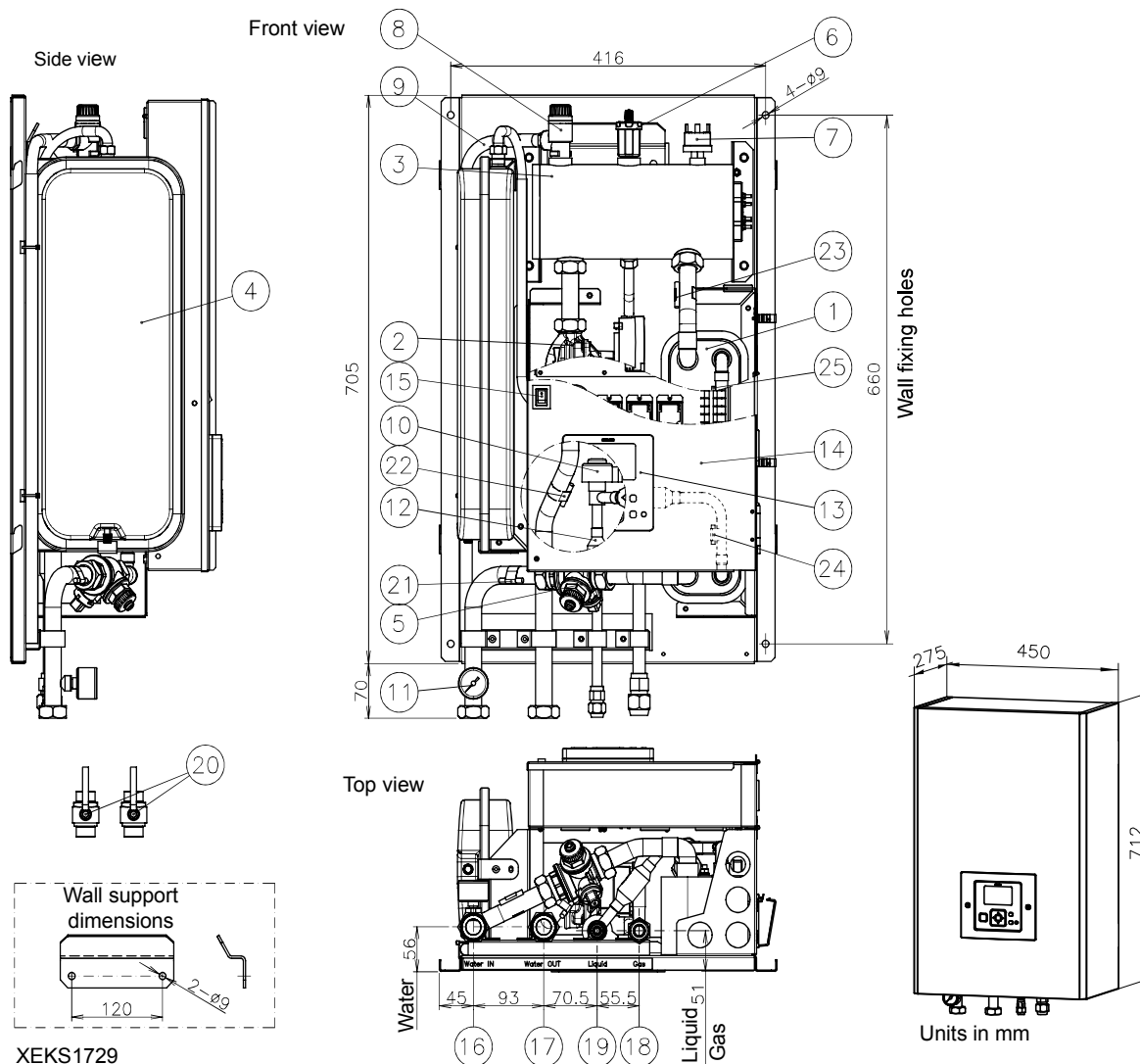

XEKS1729

N°	Part name	N°	Part name
1	Plate heat exchanger	13	Unit controller (Except (-W) models)
2	Water pump	14	Electrical box
3	Electric water heater	15	Switch for DHW emergency operation
4	Expansion vessel 6L	16	Water inlet pipe connection - G 1" Female
5	Water strainer	17	Water outlet pipe connection - G 1" Female
6	Air purger	18	Refrigerant gas pipe connection - Ø15.88 (5/8")
7	Water low pressure switch	19	Refrigerant liquid pipe connection 2.0HP: Ø6.35 (1/4") 2.5/3.0HP: Ø9.52 (3/8")
8	Safety valve	20	Shut-off valve (Factory-supplied accessory)
9	Drain pipe for safety valve	21	Thermistor (Water inlet pipe)
10	Expansion valve	22	Thermistor (Water outlet pipe)
11	Manometer	23	Thermistor (Water outlet PHEX)
12	Refrigerant strainer (x2)	24	Thermistor (Liquid refrigerant pipe)
		25	Thermistor (Gas refrigerant pipe)



◆ RWM-(4.0-6.0)NE(-W)

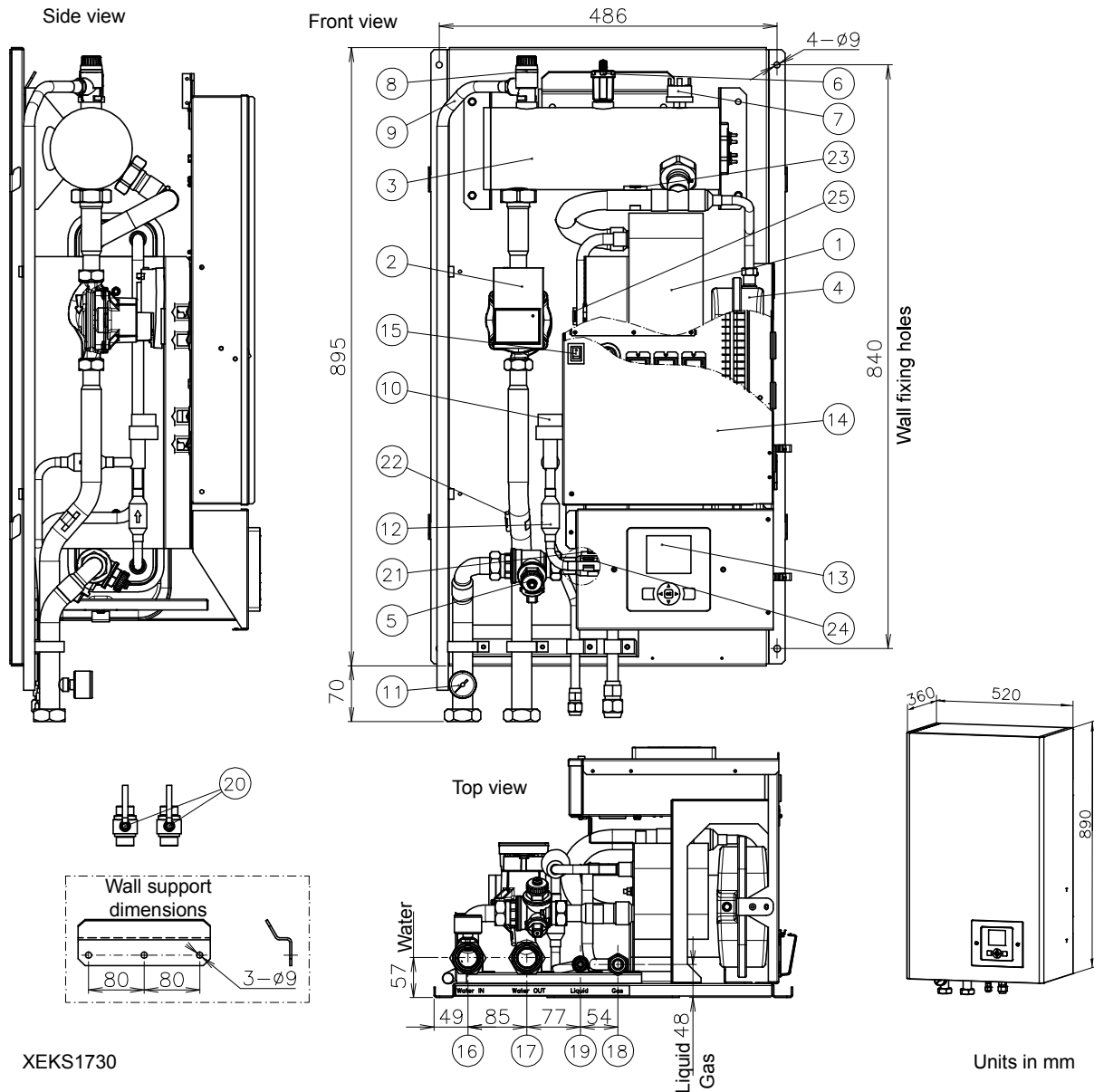

XEKS1730

Units in mm

N°	Part name	N°	Part name
1	Plate heat exchanger	13	Unit controller (Except (-W) models)
2	Water pump	14	Electrical box
3	Electric water heater	15	Switch for DHW emergency operation
4	Expansion vessel 6L	16	Water inlet pipe connection - G 1 1/4" female
5	Water strainer	17	Water outlet pipe connection - G 1 1/4" female
6	Air purger	18	Refrigerant gas pipe connection - Ø 15.88 (5/8")
7	Water low pressure switch	19	Refrigerant liquid pipe - Ø 9.52 (3/8")
8	Safety valve	20	Shut-off valve (Factory supplied accessory)
9	Drain pipe for safety valve	21	Thermistor (Water inlet pipe)
10	Expansion valve (x2)	22	Thermistor (Water outlet pipe)
11	Manometer	23	Thermistor (Water outlet PHEX)
12	Refrigerant strainer	24	Thermistor (Liquid refrigerant pipe)
		25	Thermistor (Gas refrigerant pipe)



◆ RWM-(8.0/10.0)NE(-W)

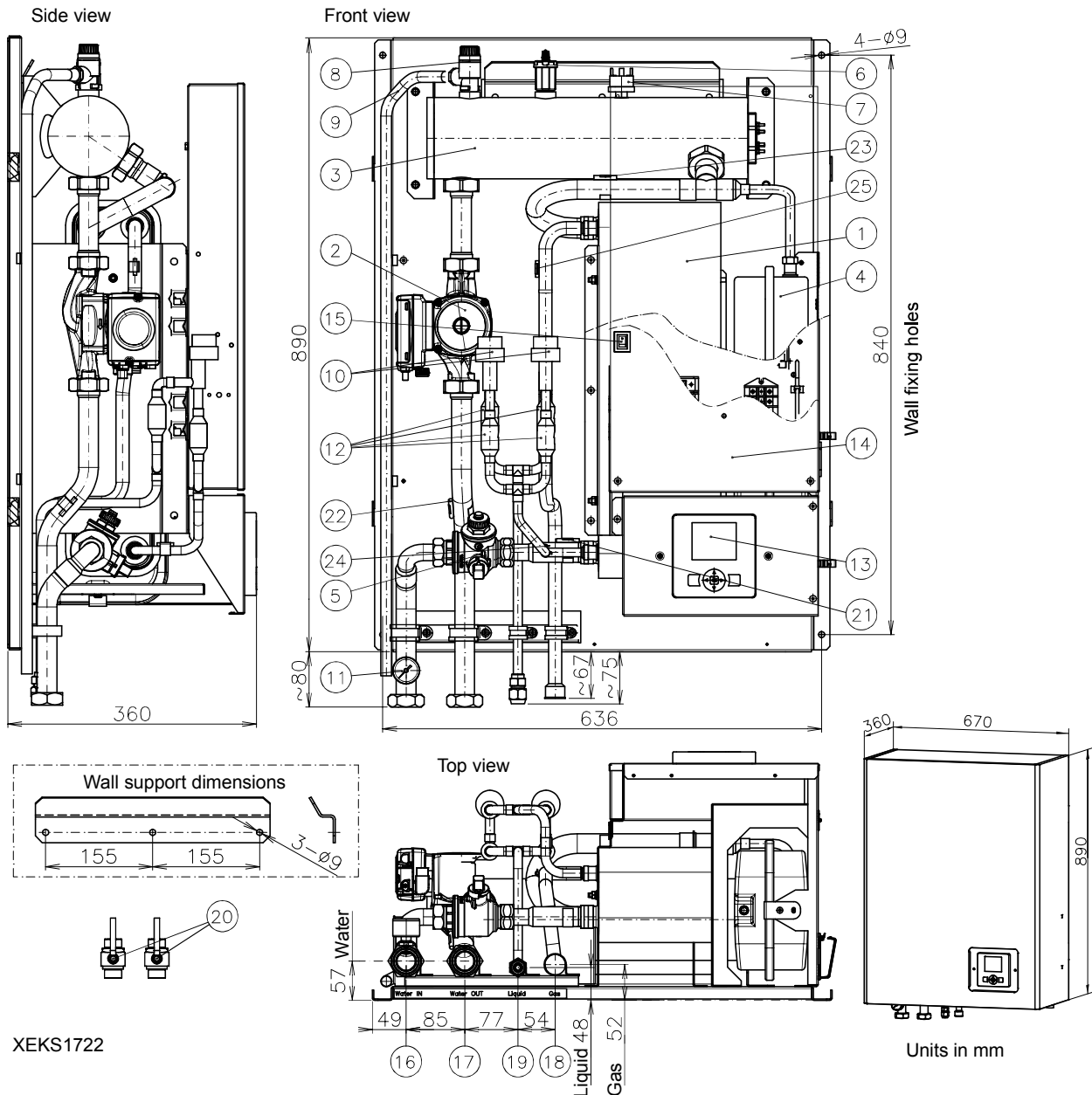

XEKS1722

Units in mm

N°	Part name	N°	Part name
1	Plate heat exchanger	13	Unit controller (Except (-W) models)
2	Water pump	14	Electrical box
3	Electric water heater	15	Switch for DHW emergency operation
4	Expansion vessel 10L	16	Water inlet pipe connection - G 1 1/4" Female
5	Water strainer	17	Water outlet pipe connection - G 1 1/4" Female
6	Air purger	18	Refrigerant gas pipe connection - Ø25.4 (1")
7	Water low pressure switch	19	Refrigerant liquid pipe connection 8HP: Ø9.52 (3/8") 10HP: Ø12.7 (1/2")
8	Safety valve	20	Shut-off valve (factory-supplied accessory)
9	Drain pipe for safety valve	21	Thermistor (Water inlet pipe)
10	Expansion valve (x2)	22	Thermistor (Water outlet pipe)
11	Manometer	23	Thermistor (Water outlet PHEX)
12	Refrigerant strainer (x4)	24	Thermistor (Liquid refrigerant pipe)
		25	Thermistor (Gas refrigerant pipe)

