

1. 4-Way Cassette (Type U2)

1-3. Dimensional Data

Indoor Units: S-22MU2E5B, S-28MU2E5B, S-36MU2E5B, S-45MU2E5B, S-56MU2E5B, S-60MU2E5B
S-73MU2E5B, S-90MU2E5B

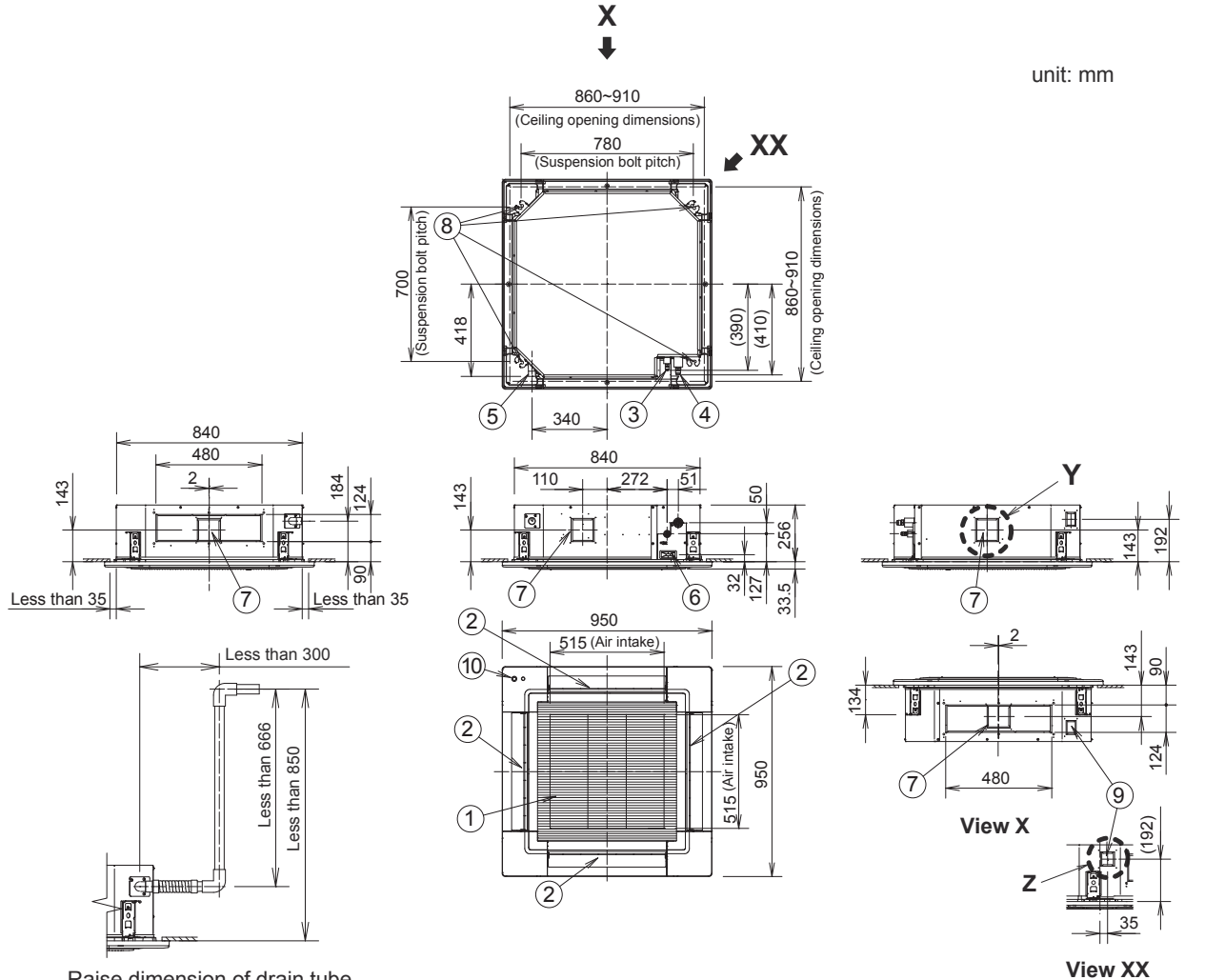

Raise dimension of drain tube

The length of the suspension bolts should be selected so that there is a gap of 30 mm or more below the lower surface of the ceiling (18 mm or more below the lower surface of the main unit), as shown in the figure at right. If the suspension bolt is too long, it will contact the ceiling panel and the unit cannot be installed.

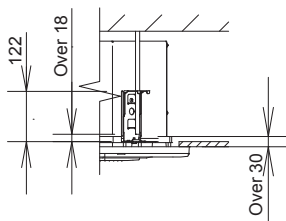

①	Air intake
②	Discharge outlet
③	Refrigerant tubing (liquid tube) 22-56 type $\phi 6.35$ (flared), 60-90 type $\phi 9.52$ (flared)
④	Refrigerant tubing (gas tube) 22-56 type $\phi 12.7$ (flared), 60-90 type $\phi 15.88$ (flared)
⑤	Drain tube connection port VP25 (outer dia. $\phi 32$)
⑥	Power supply port
⑦	Discharge duct connection port ($\phi 150$)
⑧	Suspension bolt hole (4-12 \times 30 elongated hole)
⑨	Fresh air intake duct connection port ($\phi 100$) *
⑩	ECONAVI sensor (Only CZ-KPU3A)

* Necessary to attach duct connecting flange(field supplied).

<Filter dimension>

520 \times 520 \times 15

1. 4-Way Cassette (Type U2)

Indoor Units: S-106MU2E5B, S-140MU2E5B, S-160MU2E5B

unit: mm

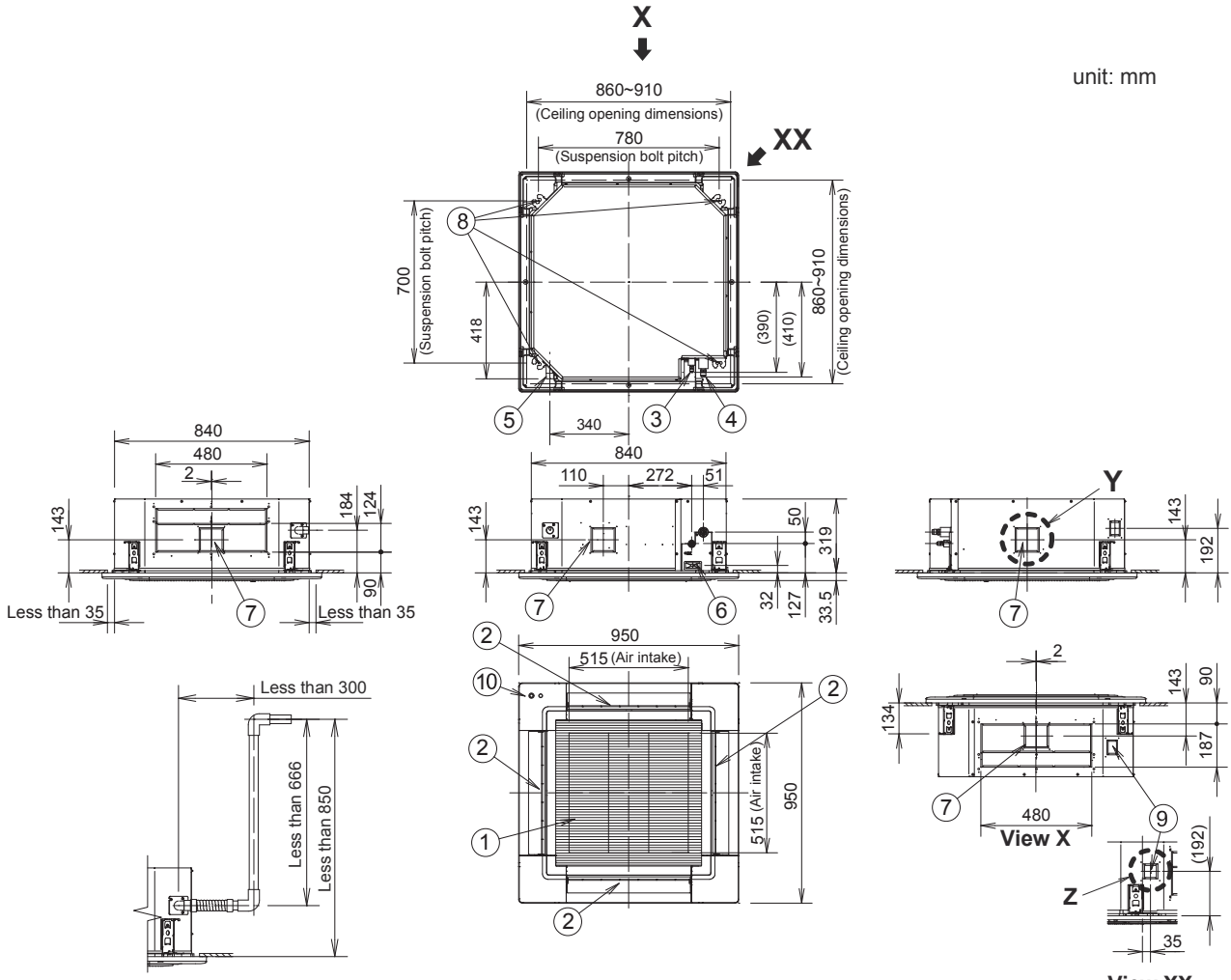

4

Raise dimension of drain tube

The length of the suspension bolts should be selected so that there is a gap of 30 mm or more below the lower surface of the ceiling (18 mm or more below the lower surface of the main unit), as shown in the figure at right. If the suspension bolt is too long, it will contact the ceiling panel and the unit cannot be installed.

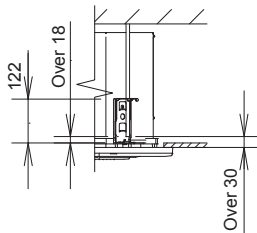

①	Air intake
②	Discharge outlet
③	Refrigerant tubing (liquid tube) $\phi 9.52$ (flared)
④	Refrigerant tubing (gas tube) $\phi 15.88$ (flared)
⑤	Drain tube connection port VP25 (outer dia. $\phi 32$)
⑥	Power supply port
⑦	Discharge duct connection port ($\phi 150$)
⑧	Suspension bolt hole (4-12 \times 30 elongated hole)
⑨	Fresh air intake duct connection port ($\phi 100$) *
⑩	ECONAVI sensor (Only CZ-KPU3A)

* Necessary to attach duct connecting flange(field supplied).

<Filter dimension>

520 \times 520 \times 15