

3. Wall Mounted (Type K2)

3-3. Dimensional Data

Indoor unit Small type: S-15MK2E5B, S-22MK2E5B, S-28MK2E5B, S-36MK2E5B

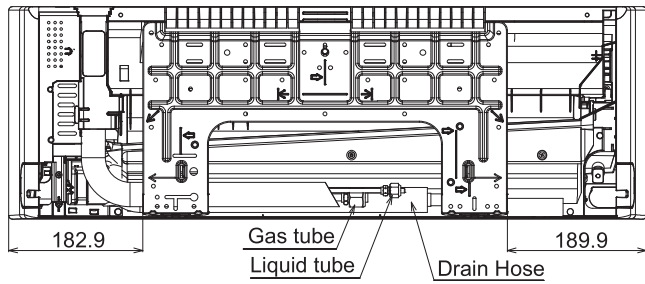
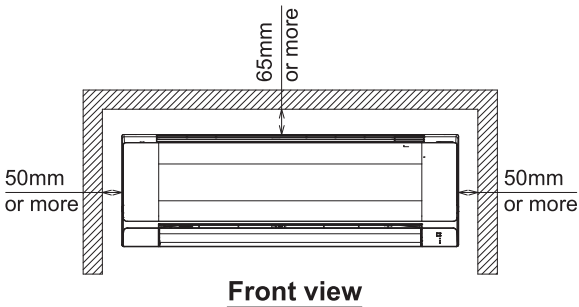
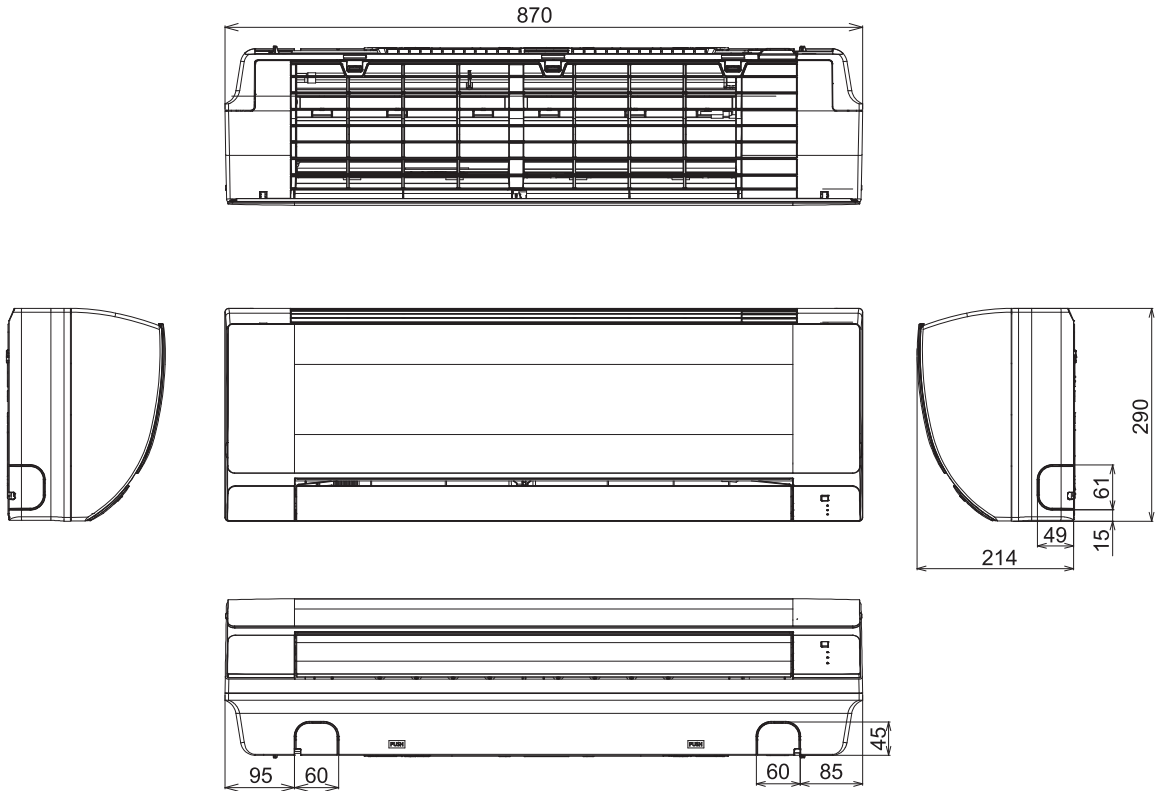

4

unit: mm

①	Refrigerant tubing (liquid tube) Ø6.35(flared)
②	Refrigerant tubing (gas tube) Ø12.7(flared)
③	Drain hose VP13 (outer dia. Ø18)
④	Rear panel (PL BACK)
⑤	Rear panel fixing holes (Ø5 holes or 5×13 oval holes)
⑥	Tubing and wiring holes (Ø70)

《 FILTER SIZE 》
(316 × 311 × 2) × 2 pcs.

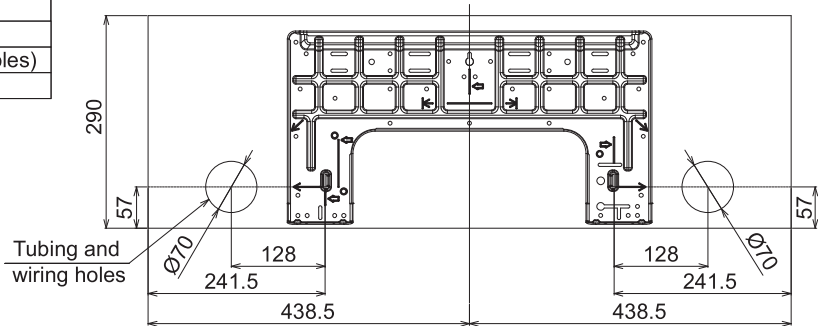

3. Wall Mounted (Type K2)

Indoor unit Large type : S-45MK2E5B, S-56MK2E5B, S-73MK2E5B, S-106MK2E5B

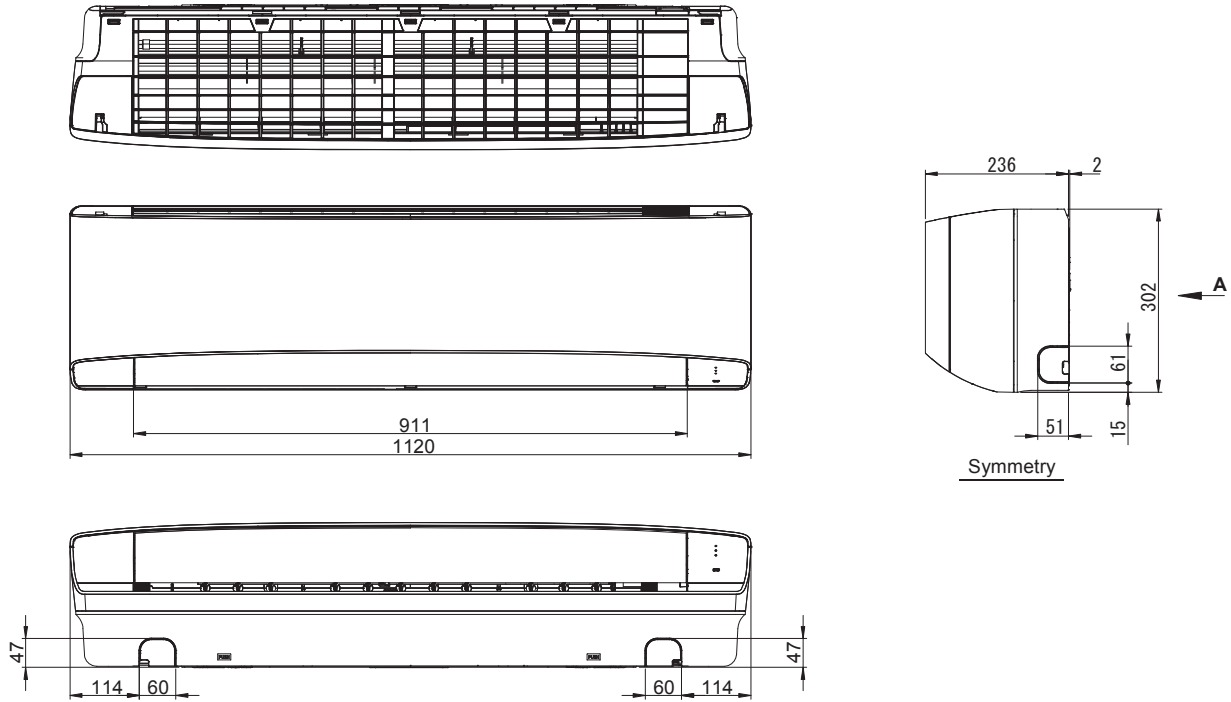

unit: mm

①	Refrigerant tubing (liquid tube)	Type 45-56	Ø6.35 (flared)
		Type 73-106	Ø9.52 (flared)
②	Refrigerant tubing (gas tube)	Type 45-56	Ø12.7 (flared)
		Type 73-106	Ø15.88 (flared)
③	Drain hose		
④	Rear panel		
⑤	Rear panel fixing holes (Ø5.3 holes or as shown in figure "C")		
⑥	Tubing and wiring holes (Ø80)		

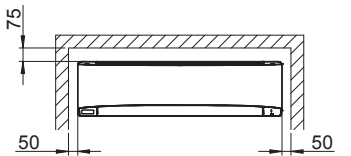
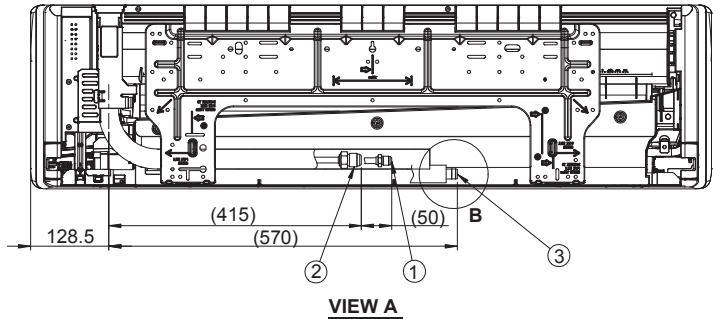

Minimum space requirements for installation

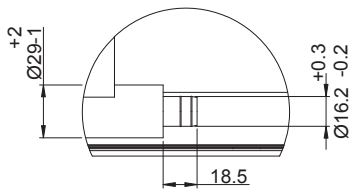

Detailed view B

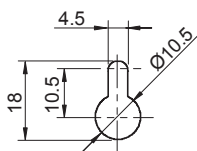

Detailed view C

