

# Panasonic

## Energy Recovery Ventilators

### Installation Manual

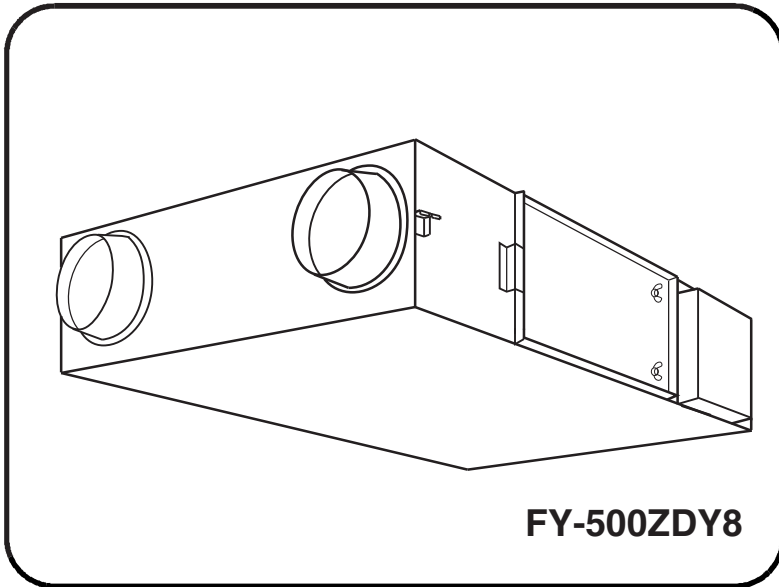

Model No.  
N° de modèle  
Modell-Nr.  
Modello N.  
Modelo N.º  
N° do modelo

**FY-250ZDY8**

**FY-350ZDY8**

**FY-500ZDY8**

**FY-650ZDY8**

**FY-800ZDY8**

**FY-01KZDY8A**

Ventilateurs d'échange de  
chaleur Panasonic  
Manuel d'installation

Panasonic Lüftungsgerät  
mit Wärmerückgewinnung  
iInstallationshandbuch

Ventilatori a scambio  
termico Panasonic  
Manuale di installazione

Ventiladores de intercambio  
calorífico Panasonic  
Manual de instalación

Ventiladores de permutação  
de calor Panasonic  
Manual de instalação

ENGLISH

FRANÇAIS

DEUTSCH

ITALIANO

ESPAÑOL



PORTUGUÊS



- Read through this “Cautions on Safety” with care before installing the unit.
- Described below are the way we are stimulating your attention to what you are supposed to observe to prevent dangers to the users or other people as well as loss to the property.

# Cautions on Safety Never Fail to Observe





Never fail to observe the caution items described hereinafter because all of them refer to the critical matters on safety. The meanings of the marks or indications are described below.

- The degrees of danger or damage that is likely to occur due to the wrong use ignoring the indications are categorized for explanation as marked below.
- Kinds of the items to be observed are categorized for clarification with the following pictorial symbols.



	<b>WARNING</b>	The column with this mark shows “Conceivable Threat of Death or Serious Injury”.
	<b>CAUTION</b>	The column with this mark shows “Likelihood of Damage or Loss to Materials only”.

	This pictorial indication shows “Prohibited”.
	This pictorial indication shows “Forced Execution”.

## WARNING

	Never fail to ask the sales office from which you bought the unit or the installation service shop to install the unit. If you install it by yourself, any inappropriate installation works would cause an electric shock or a fire.		The external air intake opening should be positioned away from the exhaust openings of combustion gases etc. The intake of such gases could cause a lack of oxygen in the room. The external air intake opening should not be positioned where discharged air may directly enter it. A situation like this will lead to the room being contaminated and this may pose a health risk.
	Carry out the installation works accurately in line with this installation work manual. Improper practice of installation could cause an electric shocks or a fire.		Netting or something similar should be provided at the external air intake opening to prevent birds etc. interfering with the unit. Nests or other foreign objects should be removed. That could cause a lack of oxygen in the room.
	Choose the installation place where is endurable in quality as well as in weight, then install the unit accurately with adequate strength and completeness of installation in accordance with the installation work manual. Otherwise, it is likely to cause an electric shock, a fire, a drop of the unit, thus causing the injury on the human body.		Carry out the ground work. Never connect the ground wire to a gas pipe, a water supply pipe, a lightning conductor, a ground line of a telephone, etc. An incomplete ground wire is likely to cause an electric shock.
	Carry out electrical work in accordance with the laws and regulations prevailing in the country concerned, technical standard and explanation for work, and make absolutely sure that an exclusive circuit is used. Any insufficient capacity of power circuit and improper work can result in electric shock and fire hazard.		When the system is checked and the power cable undergoes maintenance, stop the operation, and switch the exclusive circuit breaker "OFF". Otherwise, it could cause an electric shock.

 CAUTION

 <p>Provide an exclusive circuit breaker that can completely break contacts on all the poles by more than 3mm through direct connection to the power terminals. Depending upon the environment for installation, it becomes necessary to install an earth leakage breaker.</p>	 <p>Install the power line and the connecting line with accuracy so the power source cover may not float. If the installation of the power source cover is inappropriate, the pin connection area is likely to cause a heat generation, a fire and an electric shock due to dust or powder.</p>
<p>When you want to pierce the metal duct through the metal lath or the wire lath or the metal plate of the wooden facility, do not forget to insulate electrically between the duct and the wall. Otherwise, it would cause an electric shock or an electric leakage.</p>	 <p>Never install the unit near the place where there is a fear of leakage of an inflammable gas. If gas happens to leak and stays around the unit, it is likely to cause a fire.</p>
<p>Don't use other parts than specified (including the auxiliary parts) for installation works. If you do not use the specified parts, it is likely to cause a drop of the unit, a fire, an electric shock, etc.</p>	<p>Don't use the unit at the other voltages than the rated one. It could cause a fire or an electric shock.</p>
<p>Install the outdoor duct in a falling gradient toward the outside so as to prevent water from coming in. If it is not installed so, the building is likely to be flooded, wetting the household effects.</p>	<p>Do not install the unit in locations with large amounts of oily smoke, such as food preparation areas. It could cause a fire.</p>
<p>Heat-insulate the outdoor duct (including the indoor side, if necessary) to prevent dewing. If heat insulation is not adequate, water likely goes indoor and wets the household properties.</p>	<p>Don't install the unit at the place of a high temperature or a flame. It could cause a heat generation or a fire.</p>
<p>When it is high humid and high temperature inside the ceiling, a ventilation system must be installed inside the ceiling. Otherwise, it could cause a fire or an electric leakage.</p>	<p>Do not install in locations where harmful or corrosive gasses may be present (i.e. acidic, alkali, organic solvent, paint gasses etc. from machinery or factories). Installation in such a location could cause a gas-poisoning and a fire.</p>
<p>Connect the power line and the connecting line with accuracy using the specified cables and fix them firmly so as not to put the outer stress of the cables on the pin connecting area. Incomplete connection or fixing is likely to cause a heat generation or a fire.</p>	<p>Do not install in locations with high humidity, such as close to bathroom etc. It could cause an electric shock or an electric leakage etc.</p>

# Cautions for Operation

Never fail to make the inspection opening at the specific place on the ceiling so you can perform the constant cleaning or the equipment checking of filter and heat exchange element.

- The inspection opening shown below is necessary to clean the heat exchange element and the filter as required. If not cleaned, they are likely to get clogged, resulting in degradation of performance.

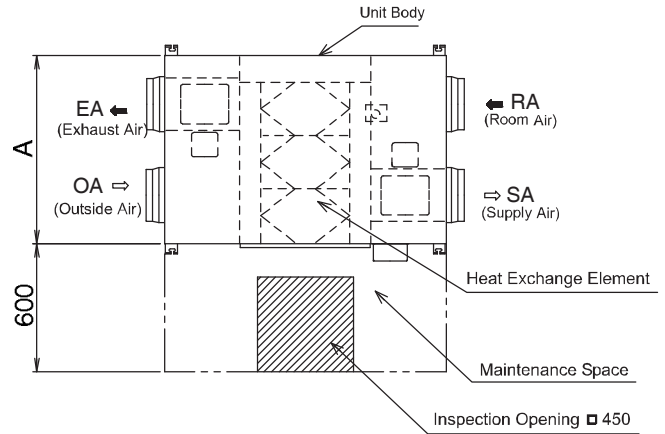
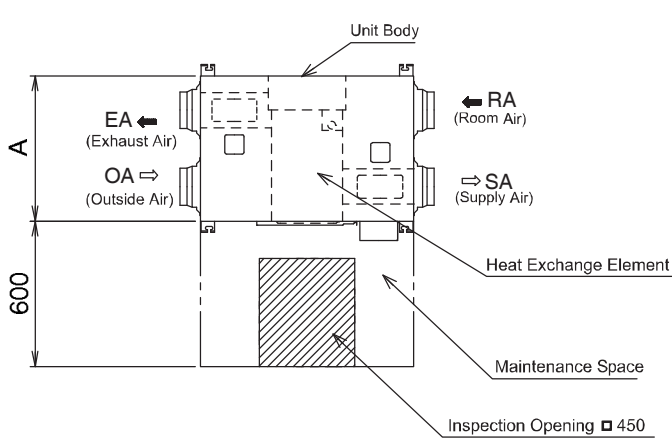

Note) Model FY-350ZDY8 and FY-500ZDY8 have two Heat Exchange Element.

Unit: mm

Model No.	A
FY-250ZDY8	599
FY-350ZDY8	804
FY-500ZDY8	904

Note) Model FY-01KZDY8A has four Heat Exchange Elements.

Unit: mm

Model No.	A
FY-650ZDY8	884
FY-800ZDY8	884
FY-01KZDY8A	1134

- This Energy Recovery Ventilators should be installed at the place where a larger space than the sizes shown below can be secured for the ceiling space.

Unit: mm

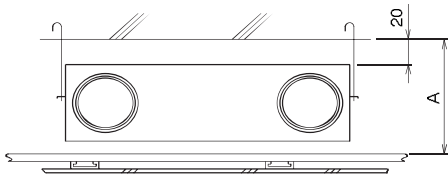

Model No.	Ceiling Space A	Model No.	Ceiling Space A
FY-250ZDY8	320	FY-650ZDY8	440
FY-350ZDY8	370	FY-800ZDY8	
FY-500ZDY8		FY-01KZDY8A	

- Don't install it near the water-heater.
- Refrain from the following duct installation works.

(1) Excessive bending



(2) Multi-times bending



(3) Making the connecting duct smaller

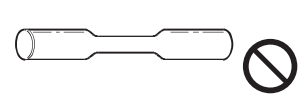

- Do not use in bathrooms or food preparation areas etc. If you use the unit at the place of much soot and high humidity, the filter or the heat exchange element gets clogged and disables you to use it.

- Use the Energy Recovery Ventilators in the ambient temperature of 40°C or less. Never install the unit at the place where the flame likely reaches directly the unit. If you use it at the atmosphere of more than 40°C for hours, it is likely to cause deterioration or deformation or damage of the resin part.

- Be careful of dewing and frosting. As shown in the figure to the right, suppose a high temp absorbing air condition A and a low temp absorbing air condition B are plotted on the air line figure, then a high temp air A is heat-exchanged by the unit and goes out of the saturation curve as shown by Point C. In this case, the unit will be dewed or frosted. To avoid this, you are required to heat a low temp air B up to B' so as to get C' below the saturation curve, before using the unit.

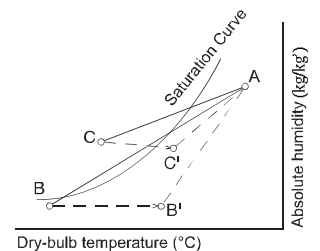

## Cautions for Installation



- Install at a stable place of sufficient strength.



Please note that there might be some places not strong enough to install due the structure of building.

■ Do not install in locations where harmful or corrosive gasses may be present (i.e. acidic, alkali, organic solvent, paint gasses etc. from machinery or factories)

Installation in such a location could cause a gas-poisoning and a fire.



Prohibited

- Never fail to install the unit inside the heat insulating walls or, in other words, in the space insulated from the open air.

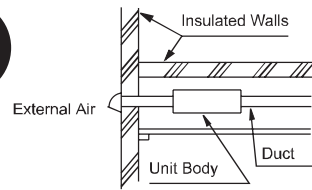

## Local Procurements

- Switches are to be locally procured.

We recommend that you use a switch having more than 3mm distance to break contact and more than 15A rated current.

## Reference Sketch

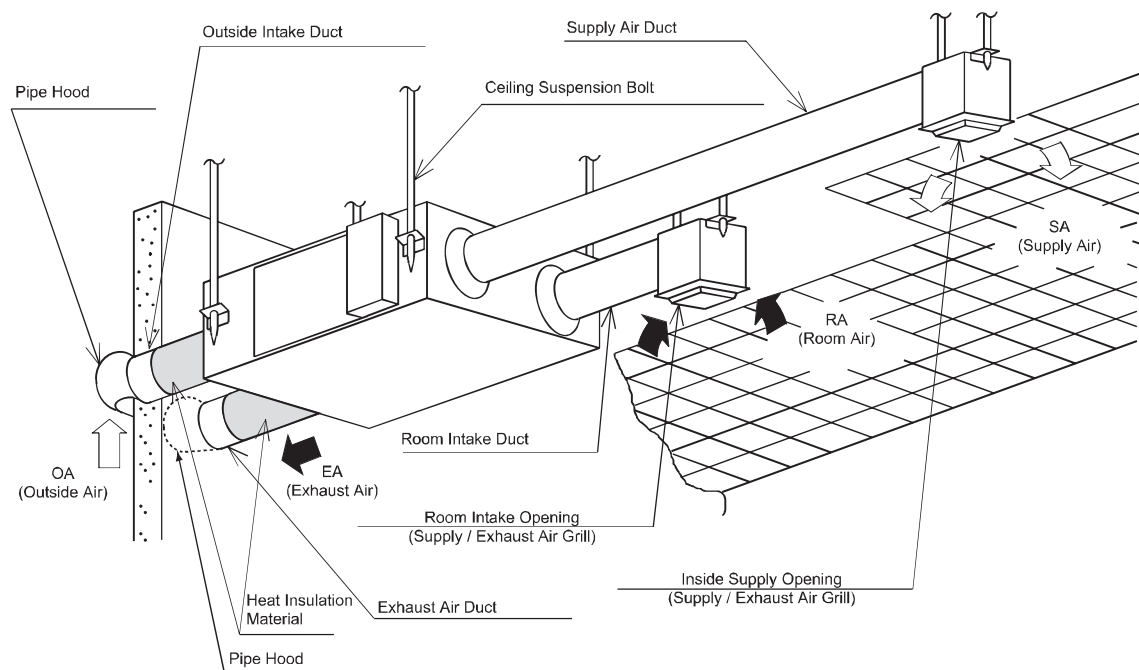

### Use conditions

**Outdoor air conditions:** Temperature range  $-10^{\circ}\text{C}$ ~ $40^{\circ}\text{C}$ , relative humidity 85% or less

**Indoor air conditions:** Temperature range  $-10^{\circ}\text{C}$ ~ $40^{\circ}\text{C}$ , relative humidity 85% or less

**Installation requirements:** Same as the indoor air conditions

\* Indoor air here means air in air-conditioned living rooms. Its use in refrigerators or other places where temperature can fluctuate greatly is prohibited even if a temperature range is acceptable.

**Example: Indoor air conditions**

**During cooling period:** Temperature  $27^{\circ}\text{C}$ , relative humidity 50%

**During heating period:** Temperature  $20^{\circ}\text{C}$ , relative humidity 40%

# Name and Dimension of Each Part

Model No. FY-250ZDY8  
FY-350ZDY8  
FY-500ZDY8

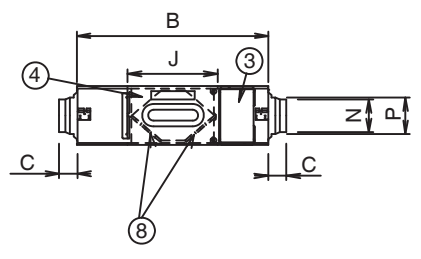
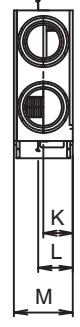
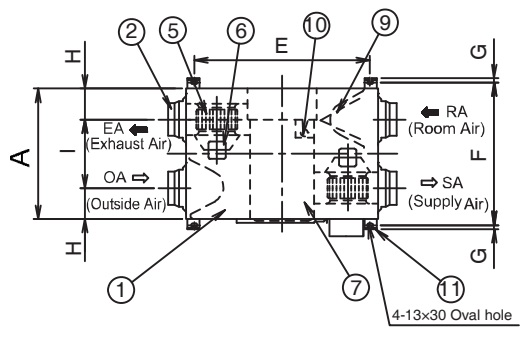

Applicable Duct

Model No.	Nominal Diameter
FY-250ZDY8	φ 150
FY-350ZDY8	φ 150
FY-500ZDY8	φ 200

Number	Name	Quantity	Note
1	Frame	1	
2	Adapler	4	
3	Terminal	1	
4	Inspection Cover	1	
5	Fan	2	
6	Motor	2	Note 2)
7	Heat Exchange element	1	Note 1)
8	Filter	2	
9	Damper	1	
10	Damper Motor	1	
11	Ceiling Suspension Fixture	4	
12	Electrical Equipment Box	1	

Note1) Model No.FY-350ZDY8 and FY-500ZDY8 have two Heat Exchange Element.  
Note2) Model No.FY-350ZDY8 and FY-500ZDY8 have different fan and motor locations.

Unit: mm

Model No.	A	B	C	E	F	G	H	I	J	K	L	M	N	P
FY-250ZDY8	599	882	95	810	655	19	142	315	414	135	159	270	φ 144	φ 164
FY-350ZDY8	804	1050	70	978	860	19	112	580	470	159	182	317	φ 144	φ 164
FY-500ZDY8	904	1090	70	1018	960	19	132	640	470	159	182	317	φ 194	φ 210

Model No. FY-650ZDY8  
FY-800ZDY8  
FY-01KZDY8A

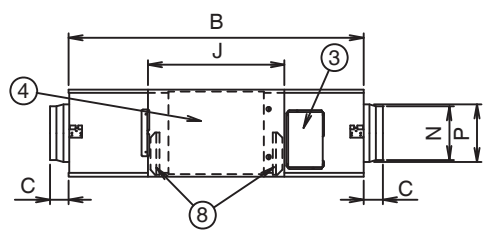
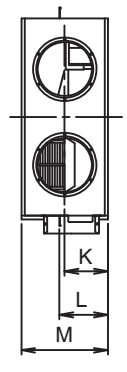
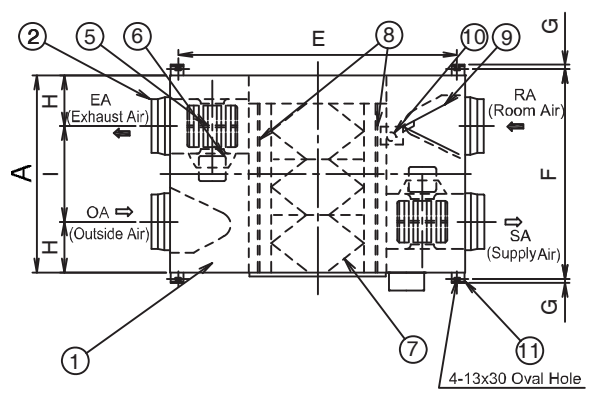

Applicable Duct

Model	Nominal Diameter
FY-650ZDY8	φ 200
FY-800ZDY8	φ 250
FY-01KZDY8A	φ 250

Number	Name	Quantity	Note
1	Frame	1	
2	Adapler	4	
3	Terminal	1	
4	Inspection Cover	1	
5	Fan	2	
6	Motor	2	Note 2)
7	Heat Exchange Element	3	Note 1)
8	Filter	2	
9	Damper	1	
10	Damper Motor	1	
11	Ceiling Suspension Fixture	4	
12	Electrical Equipment Box	1	

Note1) Model No.FY-01KZDY8A has four Heat Exchange Elements.  
Note2) Model No.FY-650ZDY8 has different fan and motor locations.

Unit: mm

Model No.	A	B	C	E	F	G	H	I	J	K	L	M	N	P
FY-650ZDY8	884	1204	70	1132	940	19	132	620	560	194	218	388	φ 194	φ 210
FY-800ZDY8	884	1322	85	1250	940	19	228	428	612	194	218	388	φ 242	φ 258
FY-01KZDY8A	1134	1322	85	1250	1190	19	228	678	612	194	218	388	φ 242	φ 258

# Installation Method

## 1. Model Installation

- You are required to prepare the ceiling suspension bolts, nuts and washers.
- Install the unit firmly and horizontally enough to support its weight. (Fig. 1)
- If you do not fit it firmly, it is not only dangerous but also easily vibrated. If it is not fitted horizontally, the damper unit becomes defective in operation.

### Caution

- When you are required to be cautious on prevention of vibration, we recommend you to use the anti-vibration ceiling suspension fixtures.
- Never fail to make an inspection opening with  $\square$  450 mm or more at the place shown on the paragraph of "Cautions For Operation", so that you can inspect filters, Heat Exchange Elements, power source and motors.

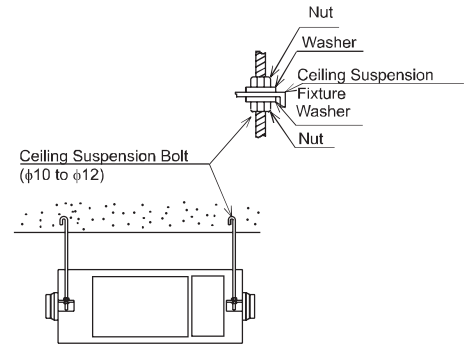

Fig. 1

## 2. Cautions on Installing The Unit Body Upside Down

- Re-fit the ceiling suspension fixture in an opposite side. (If they are left as it is, the foolproof function of ceiling suspension bolts do not work and will cause the danger of dropping of the unit.)

- Printed indication is in a reversed position.

In particular, be careful of the arrow mark [↑] showing the direction of inserting a Heat Exchange Element.

## Electric Works

Ask a specialized electrical construction operator for advice regarding wiring in accordance with "Technical Standards for Electrical Equipment" and "Interior Wiring Regulation".

- Connect wires/cables indicated by broken lines.

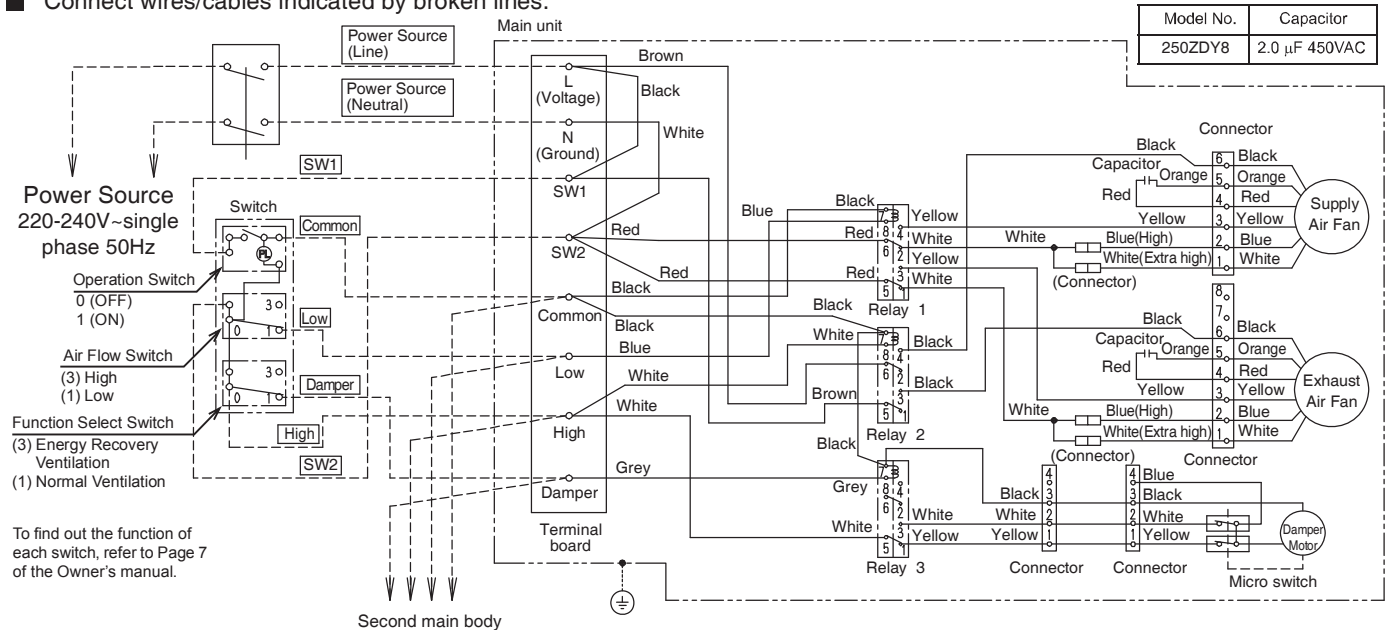

- For power supply, use a VVF cable with  $\phi$ 1.6 or  $\phi$ 2.

- Take the following steps on connect wires/cables:

- Remove two screws fixing the cover of the electrical components box, open the cover, and connect wires/cables correctly.
- Secure the cable drawn from the terminal board firmly with the cable holder.

- If a large volume of air is required or a long duct is used, switch the wire connection from Low to Extra high according to the following steps:

- Remove two screws securing the cover of the electrical components box, and open the cover.
- In the electrical components box, change the connection of fan motor leads from High to Extra high.

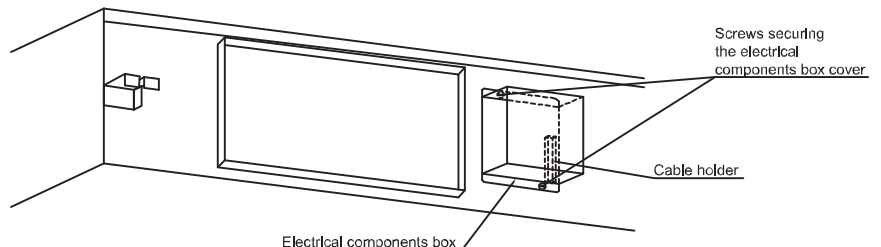
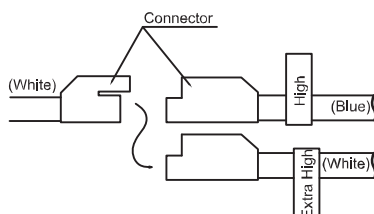

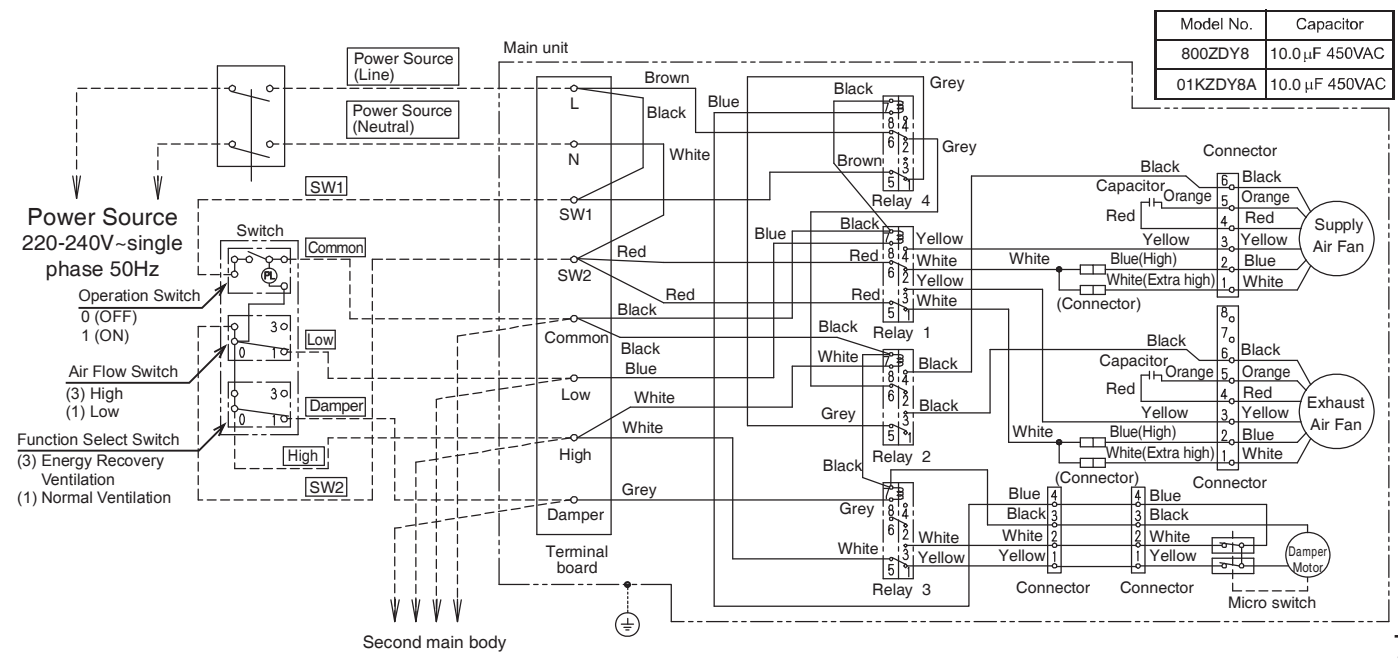
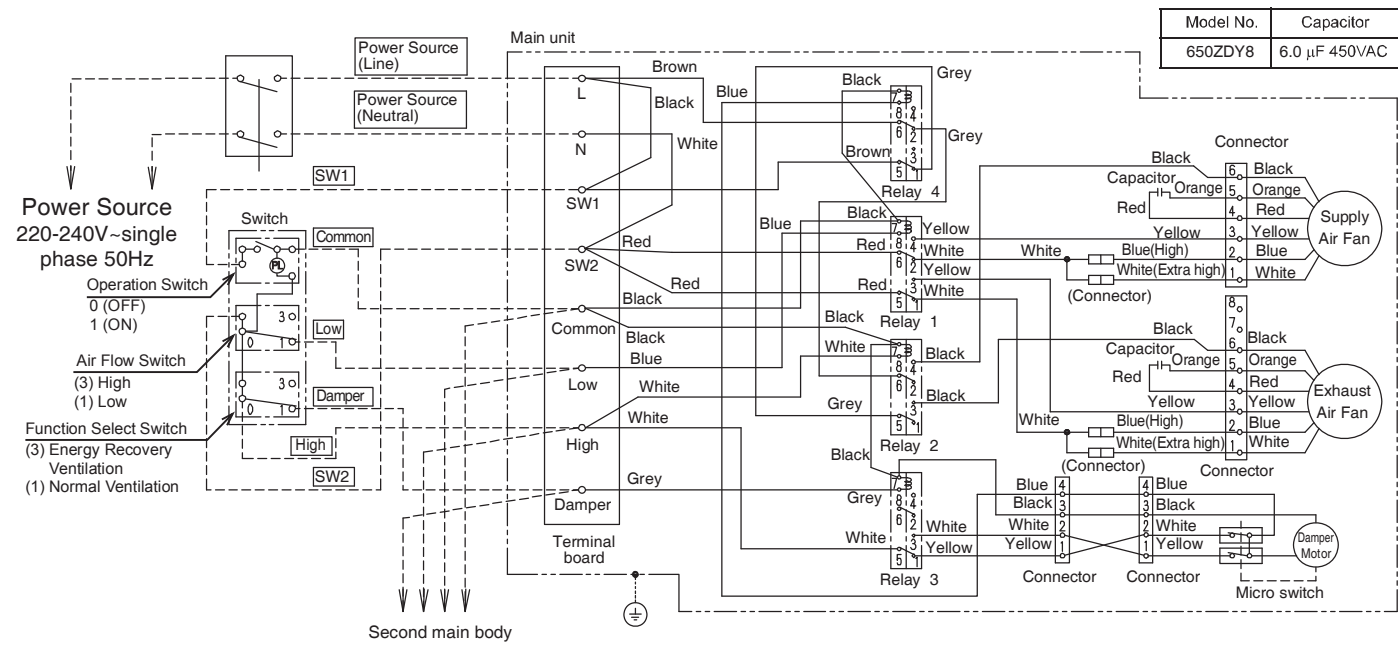
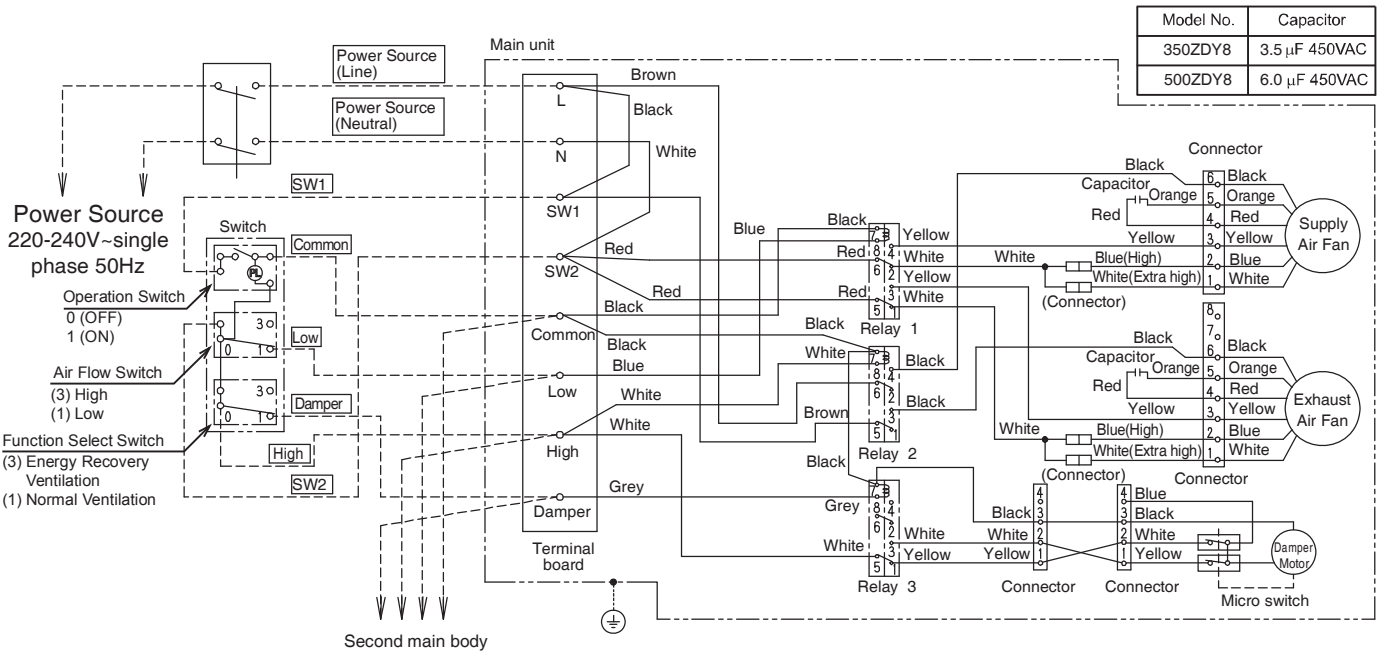



### Caution

- When operating multiple air-to-air heat exchange units using a single switch, the maximum number of units able to be operated is 10.
- Be sure to use the appropriate power supply corresponding to each model number. Using an inappropriate power supply may cause the motor to burn out.
- Grounding work must be based on Class D as defined in "Technical Standards for Electrical Equipment".
- After wire connections are completed, check the connection again before turning the power on.

## Duct Installation

- Duct installation is necessary to protect against access to live parts, rain water or contact with moving parts.
- Seal the junction of an adaptor and a duct with an aluminum tape firmly to prevent any air leakage.
- The room intake opening should be positioned as far as possible from the inside supply opening.
- Use the specified ducts. (See the Name and Dimension of Each Part.)
- Install two outdoor ducts so they will be in the down gradient toward outside to prevent water from coming in. (Gradient: 1/100~1/50) (Fig. 2)
- Never fail to heat-insulate two outdoor ducts (including outside air and exhaust air duct) to prevent dewing. (Material: Glass Wool, Thickness-25mm) (Fig. 2)
- When you want to pierce the metal duct through the metal lath or the wire lath or the metal plate of the wooden facility, do not forget to insulate electrically between the duct and the wall. (Refer to the laws and regulations of the country concerned and the technical standard.)

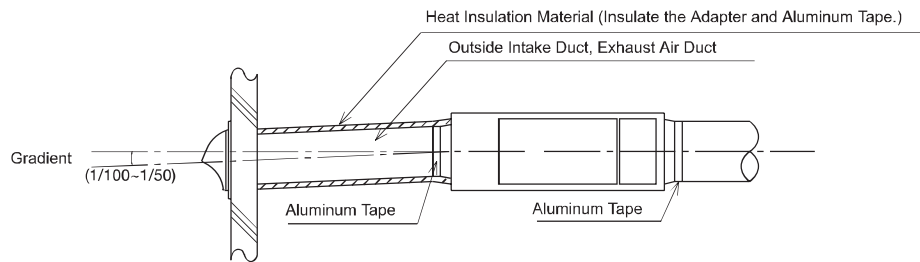

Fig. 2

## Pilot Running

- On completion of installation works, never fail to check wirings and perform a pilot running.
- After completion of wiring, power ON and perform a pilot run according to the following steps for checking a airflow condition and a damper operation.
- Check the opening and closing of a damper by opening the inspection cover of the side of the unit.
  - Model No. FY-650ZDY8, FY-800ZDY8, FY-01KZDY8A, two Fan Motors are stopped during an operation of the damper.

	Each switch setting		Checking items	
	Function Select Switch	Air Flow Switch	Airflow condition	Damper
1	Energy Recovery	High (Extra High)	Check if the air from inside supply opening and the one from room intake opening are set to High (Extra High) and to Low, respectively	Open (A Damper is beyond)
		Low		
2	Normal Ventilation	High (Extra High)	Check if the air from inside supply opening and the one from room intake opening are set to High (Extra High) and to Low, respectively	Close (A Damper is near)
		Low		

- In case that any abnormality occurs in a pilot running, its conceivable cause would be a wrong wiring. Don't forget to switch the exclusive breaker to OFF before correcting the wiring. Otherwise, it is likely to cause an electric shock.

Pursuant to at the directive 2004/108/EC, article  
Panasonic Testing Center  
Panasonic Service Europe, a division of  
Panasonic Marketing Europe GmbH  
Winsberging 15, 22525 Hamburg, F.R. Germany

**Panasonic Ecology Systems Co., Ltd.**

Web site: <http://panasonic.net>

Printed in China  
Gedruckt in China  
Imprimé en Chine  
Impreso en China  
Stampato in Cina  
Impresso na China  
B0213-1033 25ZDY80854A