

SUZ-KA25VA3.TH  
 SUZ-KA35VA3.TH

Unit: mm

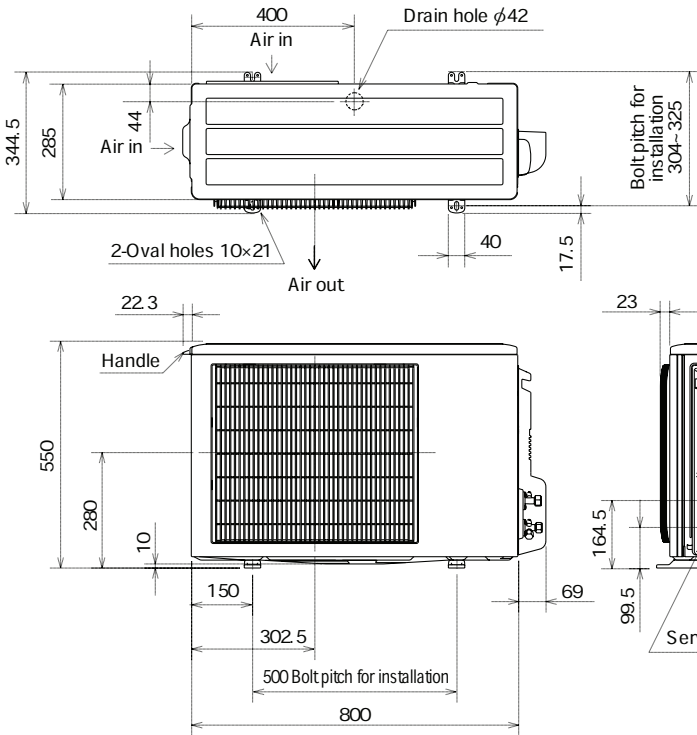

REQUIRED SPACE

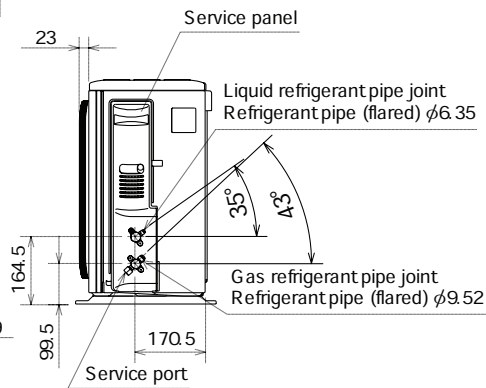
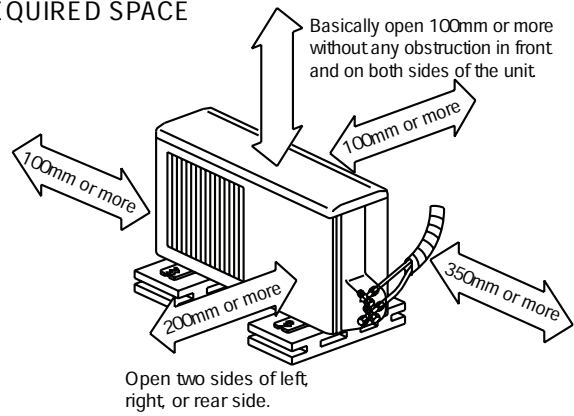

**SUZ-KA50VA3.TH**  
**SUZ-KA60VA3.TH**  
**SUZ-KA71VA3.TH**

Unit: mm

