

7.1.8 RPK-(0.8-4.0)FSN3M / RPK-(0.8/1.5)FSNH3M with expansion valve kit EV-1.5N1 - Wall type

◆ **RPK-(0.8-1.0)FSN(H)3M - Wall type**

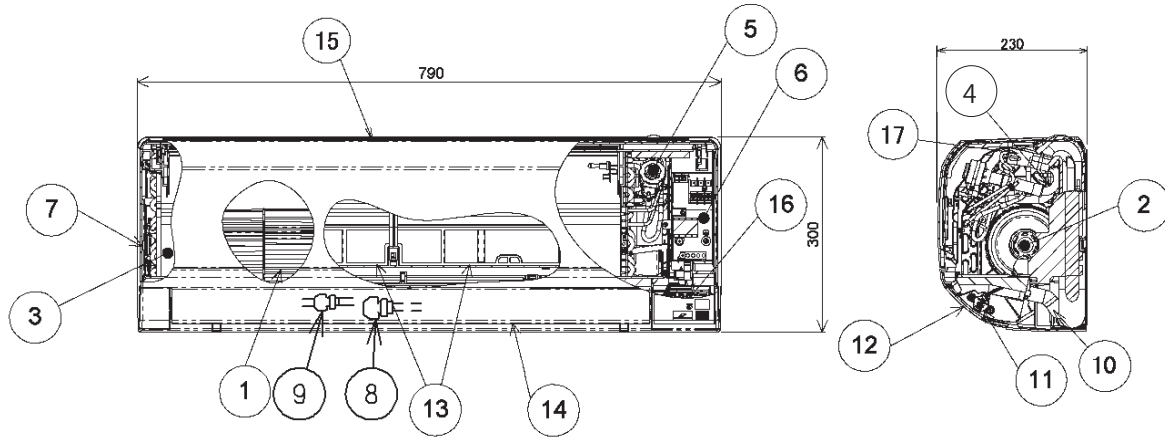

No.	Description	No.	Description
1	Fan	10	Drain Pipe Connection
2	Fan Motor	11	Auto Louver Motor
3	Heat Exchanger	12	Drain Pan
4	Strainer	13	Air Filter
5	Micro-Computer Control Expansion Valve	14	Air Outlet
6	Electrical Control Box	15	Air Inlet
7	Bearing	16	Receiver Part
8	Refrigerant Gas Pipe Connection	17	Distributor
9	Refrigerant Liquid Pipe Connection		

All measurements are in mm.

◆ **RPK-1.5FSN(H)3M - Wall type**

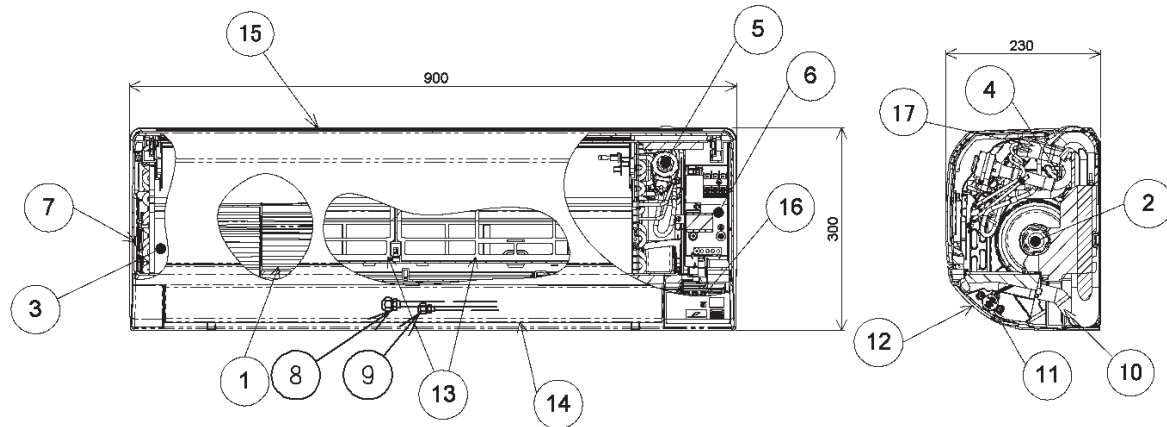

No.	Description	No.	Description
1	Fan	10	Drain Pipe Connection
2	Fan Motor	11	Auto Louver Motor
3	Heat Exchanger	12	Drain Pan
4	Strainer	13	Air Filter
5	Micro-Computer Control Expansion Valve	14	Air Outlet
6	Electrical Control Box	15	Air Inlet
7	Bearing	16	Receiver Part
8	Refrigerant Gas Pipe Connection	17	Distributor
9	Refrigerant Liquid Pipe Connection		

All measurements are in mm.



◆ **RPK-(2.0-4.0)FSN3M - Wall type**

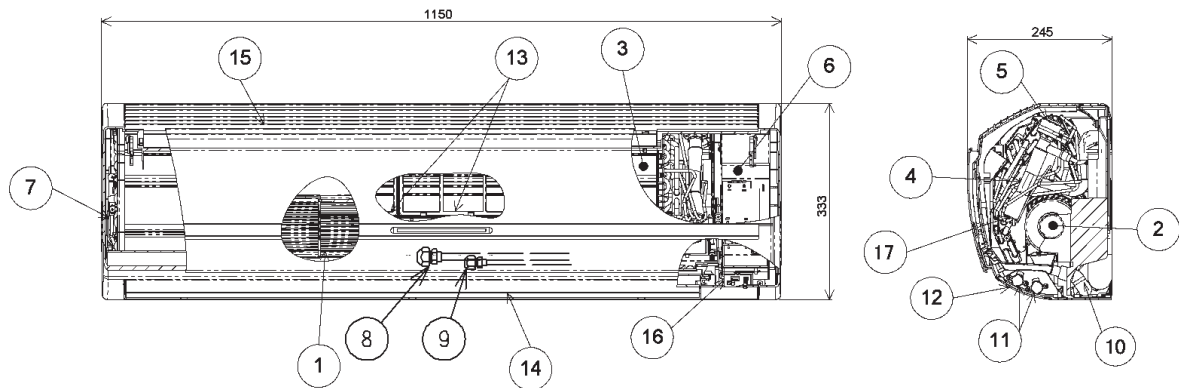

No.	Description	No.	Description
1	Fan	10	Drain Pipe Connection
2	Fan Motor	11	Auto Louver Motor
3	Heat Exchanger	12	Drain Pan
4	Strainer	13	Air Filter
5	Micro-Computer Control Expansion Valve	14	Air Outlet
6	Electrical Control Box	15	Air Inlet
7	Bearing	16	Receiver Part
8	Refrigerant Gas Pipe Connection	17	Distributor
9	Refrigerant Liquid Pipe Connection		

All measurements are in mm.