

7.1.6 RPI-(0.8-10.0)FSN(3/4)E - Indoor ducted unit

◆ **RPI-(0.8-1.5)FSN4E - Indoor ducted unit**

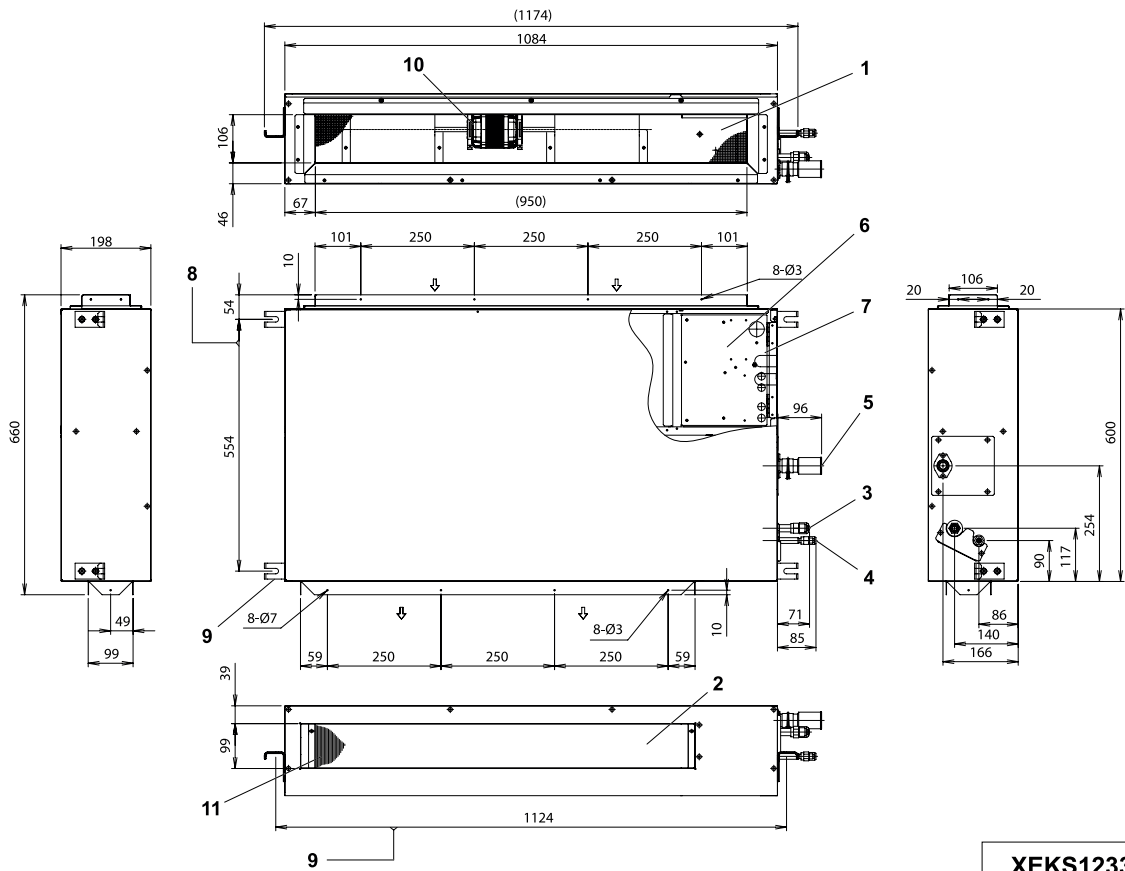

XEKS1233

| No. | Description | Remarks |
|-----|---------------------------------|----------------------|
| 1 | Air inlet | |
| 2 | Air outlet | |
| 3 | Refrigerant connection (gas) | Flare nut. ø12.7 |
| 4 | Refrigerant connection (liquid) | Flare nut. ø6.35 |
| 5 | Drain connection | ø32 (outer diameter) |
| 6 | Electrical box | |
| 7 | Wiring hole | |
| 8 | Unit suspension bolt | (4x) M10 or W3/8 |
| 9 | Unit suspension bracket | (4x) 12x35 (holes) |
| 10 | Fan motor | 4 x ø20 |
| 11 | Evaporator | |

All measurements are in mm.

◆ RPI-(2.0-6.0)FSN4E - Indoor ducted unit

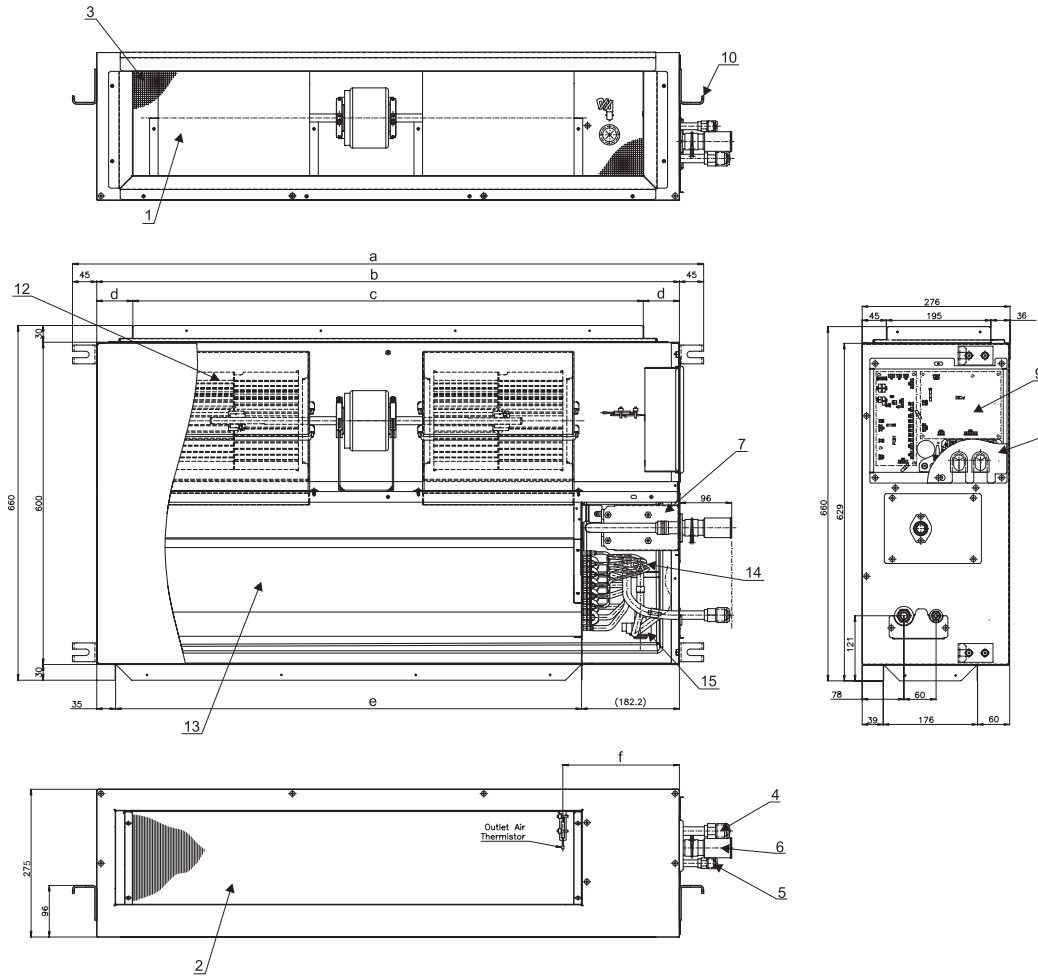

XEK01237

| No. | Description | No. | Description |
|-----|-------------------------------|-----|-----------------|
| 1 | Air inlet | 11 | Fan motor |
| 2 | Air outlet | 12 | Fan |
| 3 | Air filter | 13 | Heat exchanger |
| 4 | Refrigerant gas connection | 14 | Header |
| 5 | Refrigerant liquid connection | 15 | Expansion valve |
| 6 | Drain pipe connection | | |
| 7 | Drain pump mechanism | | |
| 8 | Electrical box cover | | |
| 9 | Electrical wiring diagram | | |
| 10 | Unit suspension bracket | | |

| Models | a | b | c | d | e | f |
|--------------------|------|------|------|-----|------|-----|
| RPI-(2.0-3.0)FSN4E | 1174 | 1084 | 950 | 67 | 867 | 217 |
| RPI-(4.0-6.0)FSN4E | 1564 | 1474 | 1240 | 117 | 1257 | 414 |

All measurements are in mm.



◆ RPI-(8.0-10.0)FSN3E - Indoor ducted unit

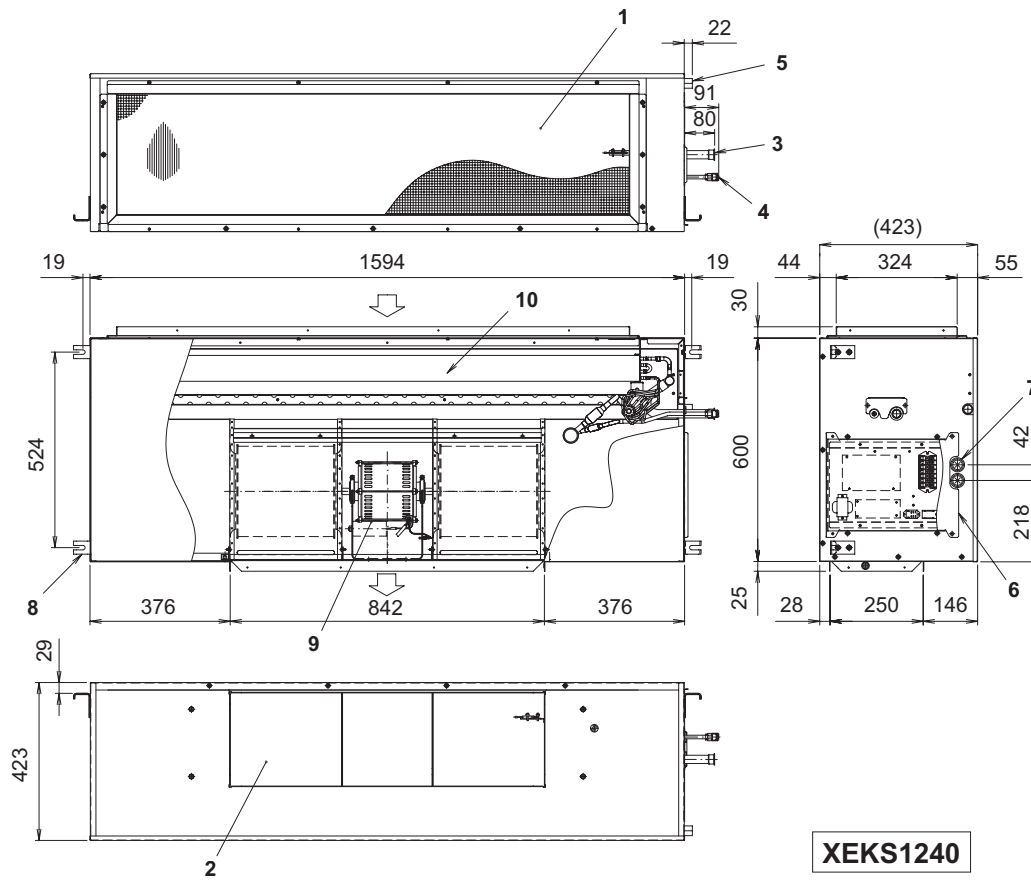

| No. | Description | Remarks |
|-----|---------------------------------|------------------------------------|
| 1 | Air inlet | |
| 2 | Air outlet | |
| 3 | Refrigerant connection (gas) | ø19.05 RPI-(8.0), ø22.2 RPI-(10.0) |
| 4 | Refrigerant connection (liquid) | Flare nut. ø9.53 RPI-(8.0/10.0) |
| 5 | Drain connection | ø25 (outer diameter) |
| 6 | Electrical box | |
| 7 | Wiring hole | |
| 8 | Unit suspension bracket | (4x) |
| 9 | Fan motor | |
| 10 | Evaporator | |

All measurements are in mm.

7.1.7 RPIM-(0.8-1.5)FSN4E(-DU) - Indoor ducted unit

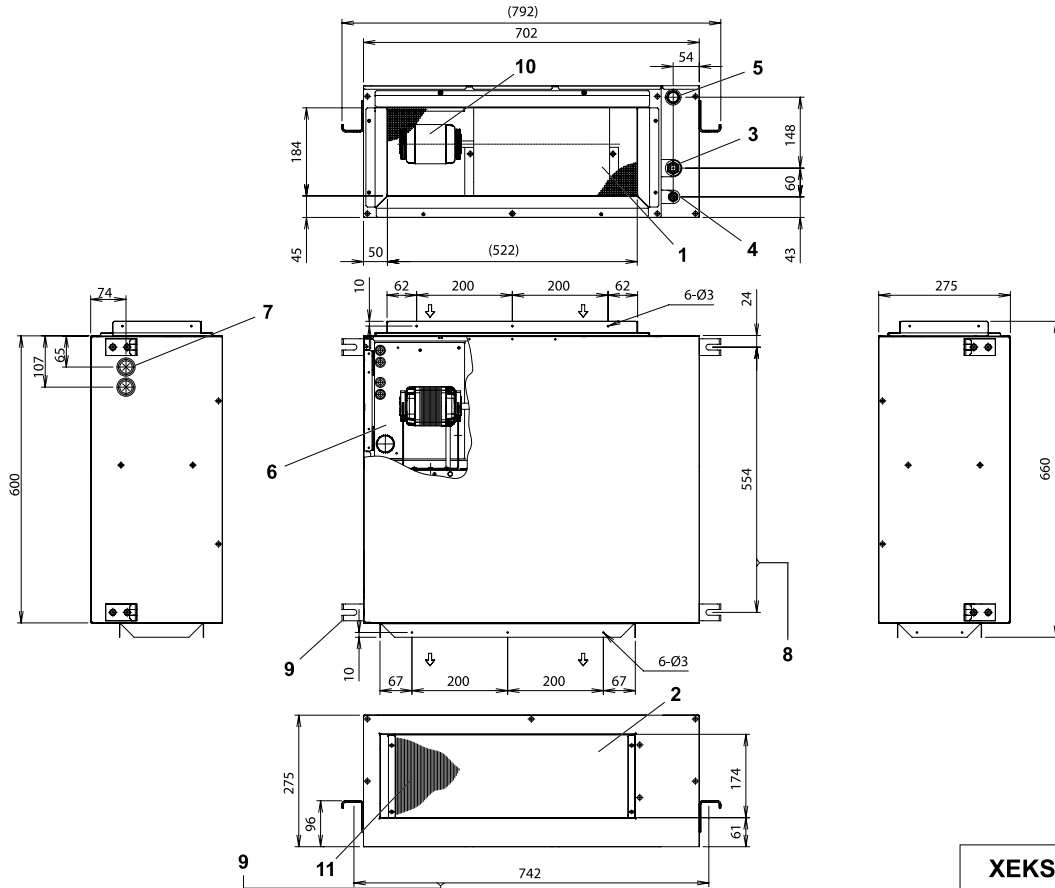

XEKS1234



| No. | Description | Remarks |
|-----|---------------------------------|----------------------------|
| 1 | Air inlet | |
| 2 | Air outlet | |
| 3 | Refrigerant connection (gas) | Flare nut. $\phi 12.7$ |
| 4 | Refrigerant connection (liquid) | Flare nut. $\phi 6.35$ |
| 5 | Drain connection | $\phi 32$ (outer diameter) |
| 6 | Electrical box | |
| 7 | Wiring hole | |
| 8 | Unit suspension bolt | (4x) M10 or W3/8 |
| 9 | Unit suspension bracket | (4x) 12x35 (holes) |
| 10 | Fan motor | |
| 11 | Evaporator | |

All measurements are in mm.