

CONSTRUCTION AND DIMENSIONAL DIAGRAM

MODEL RAI-25RPA, RAI-35RPA, RAI-50RPA

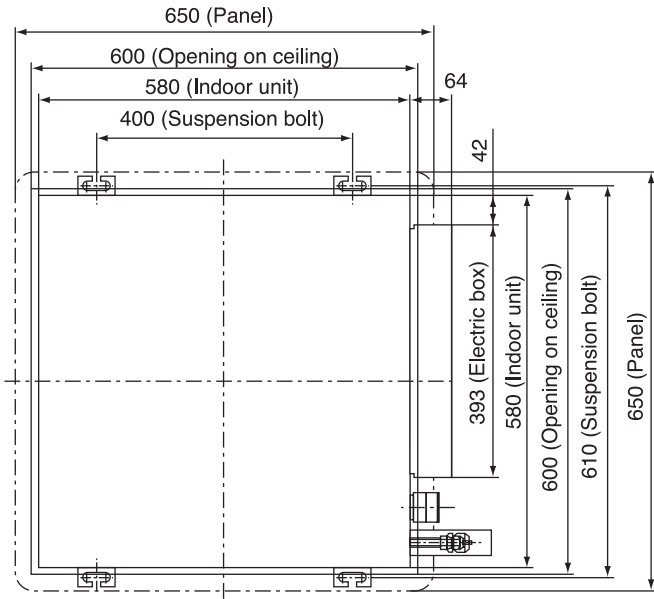

Wireless remote controller

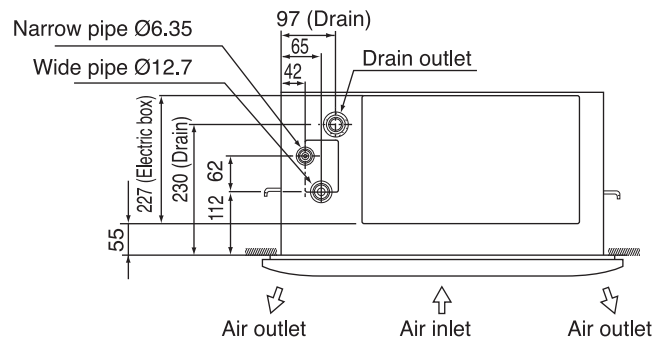
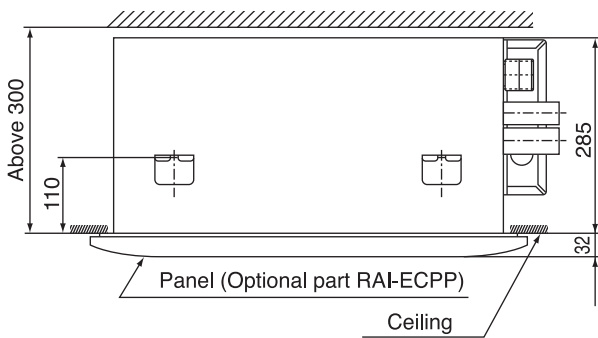

Note:

1. Insulated pipes should be used for both the narrow and wide dia. pipes.
2. Piping length is within 20m.
3. Height difference of the piping between the indoor unit and the outdoor unit should be within 10m.
4. An F-cable 1.6mm or 2.0mm dia. X 3 (control side) is used for the connection cable.

3.2. MONOZONE / MULTIZONE OUTDOOR UNITS

3.2.1. MONOZONE: RAC-25NPA/35NPA

Unit: mm

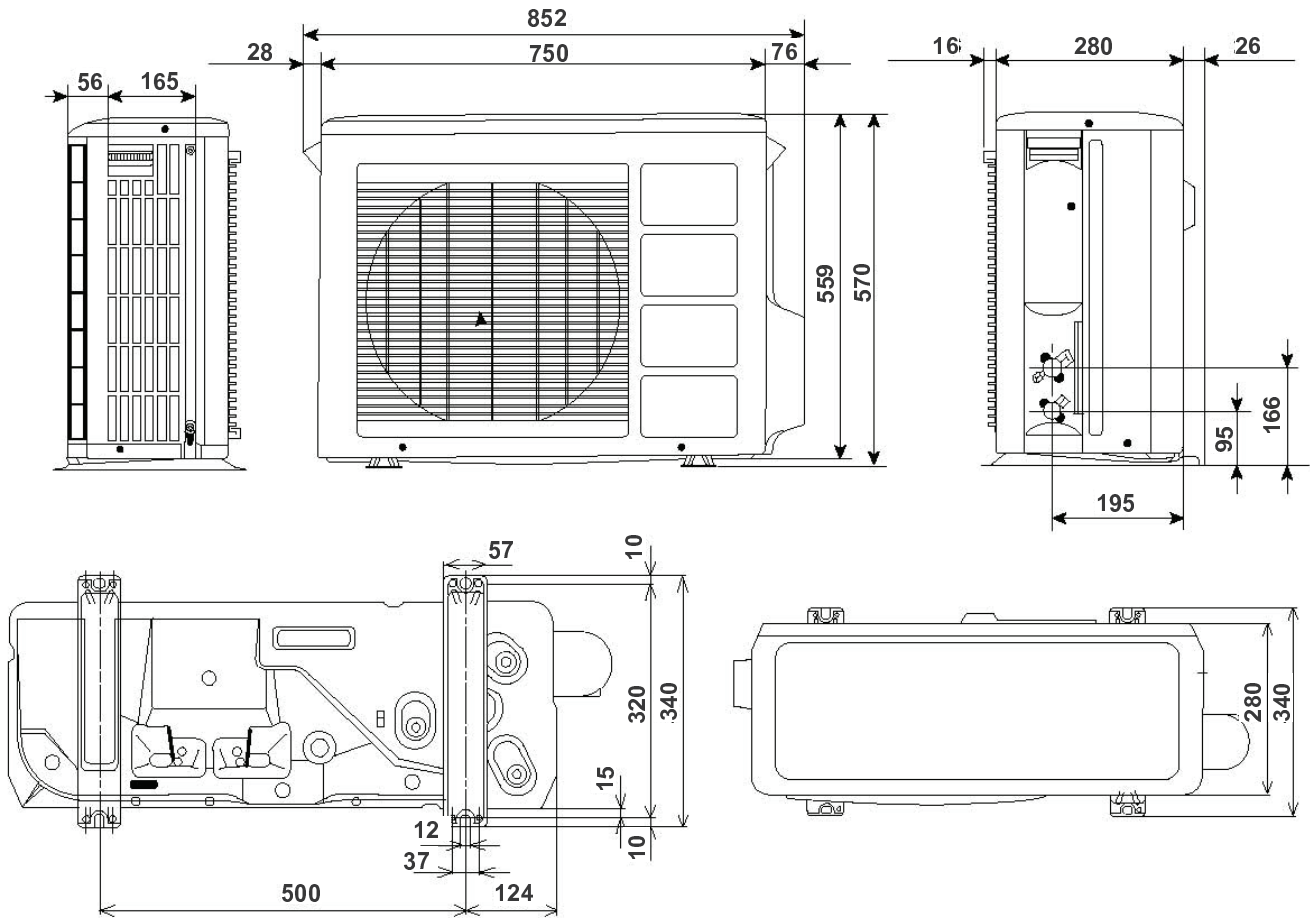

3.2.2. MONOZONE: RAC-50NPA

Unit: mm

