

## INSTALLATION & OPERATION MANUAL

### INDOOR UNITS SYSTEM FREE

Wall mounted type



### MODELS

RPK-(0.4-4.0)FSR(H)M

**EN** INSTALLATION AND OPERATION MANUAL  
**ES** MANUAL DE INSTALACIÓN Y FUNCIONAMIENTO  
**DE** INSTALLATIONS- UND BETRIEBSHANDBUCH  
**FR** MANUEL D'INSTALLATION ET DE FONCTIONNEMENT  
**IT** MANUALE D'INSTALLAZIONE E D'USO  
**PT** MANUAL DE INSTALAÇÃO E DE FUNCIONAMENTO  
**DA** INSTALLATIONS- OG BETJENINGSVEJLEDNING  
**NL** INSTALLATIE- EN BEDIENINGSHANDLEIDING  
**SV** INSTALLATION- OCH DRIFTHANDBOK  
**EL** ΕΓΧΕΙΡΙΔΙΟ ΕΓΚΑΤΑΣΤΑΣΗΣ ΚΑΙ ΛΕΙΤΟΥΡΓΙΑΣ

**BG** РЪКОВОДСТВО ЗА ИНСТАЛИРАНЕ И ЕКСПЛОАТАЦИЯ  
**CS** NÁVOD K MONTÁŽI A OBSLUZE  
**ET** PAIGALDUS- JA KASUTUSJUHEND  
**HU** TELEPÍTÉSI ÉS ÜZEMELTETÉSI ÚTMUTATÓ  
**LV** UZSTĀDĪŠANAS UN EKSPLOATĀCIJAS ROKASGRĀMATA  
**LT** MONTAVIMO IR NAUDOJIMO VADOVĀ  
**PL** INSTRUKCJA MONTAŻU I OBSŁUGI  
**RO** MANUAL DE INSTALARE SI OPERARE  
**RU** ИНСТРУКЦИЯ ПО МОНТАЖУ И ЭКСПЛУАТАЦИИ

Cooling & Heating



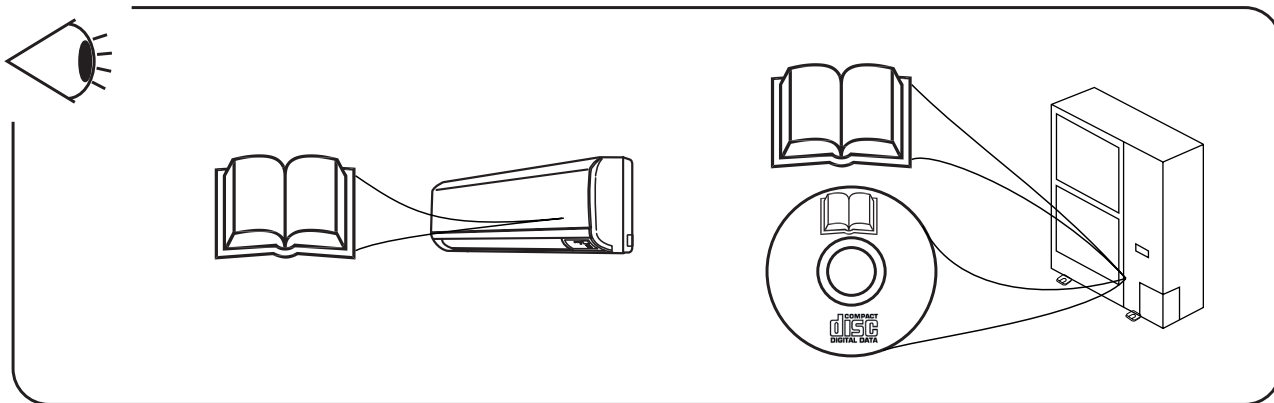

### **English**

Specifications in this manual are subject to change without notice in order that Hitachi may bring the latest innovations to their customers. Whilst every effort is made to ensure that all specifications are correct, printing errors are beyond Hitachi's control; Hitachi cannot be held responsible for these errors.

### **Español**

Las especificaciones de este manual están sujetas a cambios sin previo aviso a fin de que Hitachi pueda ofrecer las últimas innovaciones a sus clientes.

A pesar de que se hacen todos los esfuerzos posibles para asegurarse de que las especificaciones sean correctas, los errores de impresión están fuera del control de Hitachi, a quien no se hará responsable de ellos.

### **Deutsch**

Bei den technischen Angaben in diesem Handbuch sind Änderungen vorbehalten, damit Hitachi seinen Kunden die jeweils neuesten Innovationen präsentieren kann.

Sämtliche Anstrengungen wurden unternommen, um sicherzustellen, dass alle technischen Informationen ohne Fehler veröffentlicht worden sind. Für Druckfehler kann Hitachi jedoch keine Verantwortung übernehmen, da sie außerhalb ihrer Kontrolle liegen.

### **Français**

Les caractéristiques publiées dans ce manuel peuvent être modifiées sans préavis, Hitachi souhaitant pouvoir toujours offrir à ses clients les dernières innovations.

Bien que tous les efforts sont faits pour assurer l'exactitude des caractéristiques, les erreurs d'impression sont hors du contrôle de Hitachi qui ne pourrait en être tenu responsable.

### **Italiano**

Le specifiche di questo manuale sono soggette a modifica senza preavviso affinché Hitachi possa offrire ai propri clienti le ultime novità.

Sebbene sia stata posta la massima cura nel garantire la correttezza dei dati, Hitachi non è responsabile per eventuali errori di stampa che esulano dal proprio controllo.

### **Português**

As especificações apresentadas neste manual estão sujeitas a alterações sem aviso prévio, de modo a que a Hitachi possa oferecer aos seus clientes, da forma mais expedita possível, as inovações mais recentes. Apesar de serem feitos todos os esforços para assegurar que todas as especificações apresentadas são correctas, quaisquer erros de impressão estão fora do controlo da Hitachi, que não pode ser responsabilizada por estes erros eventuais.

### **Dansk**

Specifikationerne i denne vejledning kan ændres uden varsel, for at Hitachi kan bringe de nyeste innovationer ud til kunderne. På trods af alle anstrengelser for at sikre at alle specifikationerne er korrekte, har Hitachi ikke kontrol over trykfejl, og Hitachi kan ikke holdes ansvarlig herfor.

### **Nederlands**

De specificaties in deze handleiding kunnen worden gewijzigd zonder verdere kennisgeving zodat Hitachi zijn klanten kan voorzien van de nieuwste innovaties.

Iedere poging wordt ondernomen om te zorgen dat alle specificaties juist zijn. Voorkomende drukfouten kunnen echter niet door Hitachi worden gecontroleerd, waardoor Hitachi niet aansprakelijk kan worden gesteld voor deze fouten.

### **Svenska**

Specifikationerna i den här handboken kan ändras utan föregående meddelande för att Hitachi ska kunna leverera de senaste innovationerna till kunderna.

Vi på Hitachi gör allt vi kan för att se till att alla specifikationer stämmer, men vi har ingen kontroll över tryckfel och kan därför inte hållas ansvariga för den typen av fel.

## **Ελληνικά**

Οι προδιαγραφές του εγχειριδίου μπορούν να αλλάξουν χωρίς προειδοποίηση, προκειμένου η Hitachi να παρέχει τις τελευταίες καινοτομίες στους πελάτες της.

Αν και έχει γίνει κάθε προσπάθεια προκειμένου να εξασφαλιστεί ότι οι προδιαγραφές είναι σωστές, η Hitachi δεν μπορεί να ελέγξει τα τυπογραφικά λάθη και, ως εκ τούτου, δεν φέρει καμία ευθύνη για αυτά τα λάθη.

## **Български**

Спецификациите в това ръководство подлежат на изменения без известяване, така че Hitachi да може да предоставя на своите клиенти последните иновации.

Полагат се всички усилия, за да се гарантира, че всички спецификации са коректни, но печатните грешки са извън обсега на контрола на Hitachi и Hitachi не може да носи отговорност за тези грешки.

## **Čeština**

Aby společnost Hitachi mohla svým zákazníkům poskytovat nejnovější inovace, specifikace uvedené v této příručce podléhají změnám bez předchozího upozornění.

Přestože vynakládáme maximální úsilí, aby všechny specifikace byly správné, tiskové chyby nespádají pod kontrolu společnosti Hitachi, která za takové chyby nenese odpovědnost.

## **Eesti**

Käesoleva juhendi tehnilised kirjeldused võivad muutuda ilma ette teatamiseta, selleks et Hitachi saaks tuua oma klientideni kõige uuemad innovatsioonid.

Kuigi püütakse tagada, et kõik tehnilised kirjeldused oleksid õiged, on trükivead väljaspool Hitachi kontrolli; Hitachi ei vastuta nende vigade eest.

## **Magyar**

Az alábbi kézikönyvben foglalt előírások előzetes értesítés nélkül változhatnak, annak érdekében, hogy a Hitachi a legfrissebb újításokkal szolgálhasson ügyfelei számára.

Bár minden erőfeszítést megteszünk annak érdekében, hogy minden előírás helyes legyen, a nyomtatási hibák nem állnak a Hitachi ellenőrzése alatt; ezekért a hibákért a Hitachi nem tehető felelőssé.

## **Latviešu**

Šīs rokasgrāmatas specifikācijas var mainīties bez brīdinājuma, lai Hitachi varētu saviem klientiem piedāvāt jaunākās inovācijas.

Lai gan tiek pieliktas visas pūles, nodrošinot, ka visas specifikācijas ir pareizas, drukāšanas kļūdas ir ārpus Hitachi kontroles; Hitachi nevar būt atbildīga par šīm kļūdām.

## **Lietuvių**

Šio vadovo specifikacijos gali būti keičiamos be įspėjimo, kad „Hitachi“ galėtų pateikti savo klientams paskutines naujoves.

Nors dedamos visos pastangos siekiant užtikrinti, kad visos specifikacijos būtų teisingos, „Hitachi“ nekontroliuoja spausdinimo klaidų; „Hitachi“ negali būti laikoma atsakinga už tokias klaidas.

## **Polski**

Zamieszczone w niniejszej instrukcji obsługi dane techniczne mogą ulec zmianie bez uprzedniego powiadomienia ze względu na innowacyjne rozwiązania, jakie firma Hitachi nieustannie wprowadza z myślą o swoich klientach.

Mimo podejmowanych starań, aby zapewnić poprawność wszystkich podanych tutaj informacji, nie można wykluczyć zaistnienia błędów drukarskich, za które firma Hitachi nie ponosi żadnej odpowiedzialności.

## **Română**

Specificațiile din acest manual pot fi modificate fără notificare prealabilă, pentru ca Hitachi să poată pune la dispoziția clienților noștri ultimele inovații.

Deși depunem toate eforturile pentru a ne asigura că toate specificațiile sunt corecte, erorile de tipărire depășesc controlul Hitachi; Hitachi nu poate fi tras la răspundere pentru aceste erori.

## **Русский**

Технические характеристики, содержащиеся в данном руководстве, могут быть изменены Hitachi без предварительного уведомления, по причине постоянного внедрения последних инноваций.

Несмотря на то, что мы принимаем все возможные меры для актуализации технических данных, при публикации возможны ошибки, которые Hitachi не может контролировать, и за которые не несет ответственности.



### **! ATTENTION**

This product shall not be mixed with general house waste at the end of its life and it shall be retired according to the appropriate local or national regulations in an environmentally correct way.  
Due to the refrigerant, oil and other components contained in Air Conditioner, its dismantling must be done by a professional installer according to the applicable regulations.  
Contact to the corresponding authorities for more information.



### **! ATENCIÓN**

Este producto no se debe eliminar con la basura doméstica al final de su vida útil y se debe desechar de manera respetuosa con el medio ambiente de acuerdo con los reglamentos locales o nacionales aplicables.  
Debido al refrigerante, el aceite y otros componentes contenidos en el sistema de aire acondicionado, su desmontaje debe realizarlo un instalador profesional de acuerdo con la normativa aplicable.  
Para obtener más información, póngase en contacto con las autoridades competentes.

### **! ACHTUNG**

Dass Ihr Produkt am Ende seiner Betriebsdauer nicht in den allgemeinen Hausmüll geworfen werden darf, sondern entsprechend den geltenden örtlichen und nationalen Bestimmungen auf umweltfreundliche Weise entsorgt werden muss.  
Aufgrund des Kältemittels, des Öls und anderer in der Klimaanlage enthaltener Komponenten muss die Demontage von einem Fachmann entsprechend den geltenden Vorschriften durchgeführt werden.  
Für weitere Informationen setzen Sie sich bitte mit den entsprechenden Behörden in Verbindung.

### **! ADVERTISSEMENT**

Ne doit pas être mélangé aux ordures ménagères ordinaires à la fin de sa vie utile et qu'il doit être éliminé conformément à la réglementation locale ou nationale, dans le plus strict respect de l'environnement.  
En raison du frigorigène, de l'huile et des autres composants que le climatiseur contient, son démontage doit être réalisé par un installateur professionnel conformément aux réglementations en vigueur.

### **! AVVERTENZE**

Indicazioni per il corretto smaltimento del prodotto ai sensi della Direttiva Europea 2011/65/EU e D.Lgs 4 marzo 2014 n.27  
Il simbolo del cassonetto barrato riportato sull'apparecchiatura indica che il prodotto alla fine della propria vita utile deve essere raccolto separatamente dagli altri rifiuti.  
L'utente dovrà, pertanto, conferire l'apparecchiatura giunta a fine vita agli idonei centri di raccolta differenziata dei rifiuti elettronici ed elettrotecnici, oppure riconsegnarla al rivenditore al momento dell'acquisto di una nuova apparecchiatura di tipo equivalente.  
L'adeguata raccolta differenziata delle apparecchiature dismesse, per il loro avvio al riciclaggio, al trattamento ed allo smaltimento ambientalmente compatibile, contribuisce ad evitare possibili effetti negativi sull'ambiente e sulla salute e favorisce il riciclo dei materiali di cui è composta l'apparecchiatura.  
Non tentate di smontare il sistema o l'unità da soli poiché ciò potrebbe causare effetti dannosi sulla vostra salute o sull'ambiente.  
Vogliate contattare l'installatore, il rivenditore, o le autorità locali per ulteriori informazioni.  
Lo smaltimento abusivo del prodotto da parte dell'utente può comportare l'applicazione delle sanzioni amministrative di cui all'articolo 50 e seguenti del D.Lgs. n. 22/1997.

### **! CUIDADO**

O seu produto não deve ser misturado com os desperdícios domésticos de carácter geral no final da sua duração e que deve ser eliminado de acordo com os regulamentos locais ou nacionais adequados de uma forma correcta para o meio ambiente.  
Devido ao refrigerante, ao óleo e a outros componentes contidos no Ar condicionado, a desmontagem deve ser realizada por um instalador profissional de acordo com os regulamentos aplicáveis.  
Contacte as autoridades correspondentes para obter mais informações.

### **! ADVASEL!**

At produktet ikke må smides ud sammen med almindeligt husholdningsaffald, men skal bortskaffes i overensstemmelse med de gældende lokale eller nationale regler på en miljømæssig korrekt måde.  
Da klimaanlægget indeholder kølemiddel, olie samt andre komponenter, skal afmontering foretages af en fagmand i overensstemmelse med de gældende bestemmelser.  
Kontakt de pågældende myndigheder for at få yderligere oplysninger.

### **! VOORZICHTIG**

Dit houdt in dat uw product niet wordt gemengd met gewoon huisvuil wanneer u het weg doet en dat het wordt gescheiden op een milieuvriendelijke manier volgens de geldige plaatselijke en landelijke reguleringen.  
Vanwege het koelmiddel, de olie en andere onderdelen in de airconditioner moet het apparaat volgens de geldige regulering door een professionele installateur uit elkaar gehaald worden.  
Neem contact op met de betreffende overheidsdienst voor meer informatie.

### **! FÖRSIKTIGHET**

Det innebär att produkten inte ska slängas tillsammans med vanligt hushållsavfall utan kasseras på ett miljövänligt sätt i enlighet med gällande lokal eller nationell lagstiftning.  
Luftkonditioneringsaggregatet innehåller kylmedium, olja och andra komponenter, vilket gör att det måste demonteras av en fackman i enlighet med tillämpliga regelverk.  
Ta kontakt med ansvarig myndighet om du vill ha mer information.

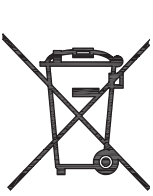

## ΠΡΟΣΟΧΗ

Σημαίνει ότι το προϊόν δεν θα πρέπει να αναμιχθεί με τα διάφορα οικιακά απορρίμματα στο τέλος του κύκλου ζωής του και θα πρέπει να αποσυρθεί σύμφωνα με τους κατάλληλους τοπικούς ή εθνικούς κανονισμούς και με τρόπο φιλικό προς το περιβάλλον.  
Λόγω του ψυκτικού, του λαδιού και άλλων στοιχείων που περιέχονται στο κλιματιστικό, η αποσυναρμολόγησή του πρέπει να γίνει από επαγγελματία τεχνικό και σύμφωνα με τους ισχύοντες κανονισμούς.  
Για περισσότερες λεπτομέρειες, επικοινωνήστε με τις αντίστοιχες αρχές.

## ВНИМАНИЕ

В края на своя технологичен живот този продукт не бива да се изхвърля заедно с общите битови отпадъци и трябва да се третира съгласно приетите местни или национални подзаконовни нормативни актове по правилен от гледна точка на опазване на околната среда начин.  
Поради охладителя, маслото и останалите компоненти, съдържащи се в климатика, разглобяването му задължително се извършва от професионален техник съгласно приложимите подзаконовни нормативни актове. За повече информация се свържете със съответните органи.

## POZOR

Tento výrobek nesmí být na konci své životnosti likvidován v rámci běžného komunálního odpadu, nýbrž ekologickým způsobem v souladu s příslušnými místními nebo vnitrostátními předpisy.  
Vzhledem k chladivu, oleji a dalším komponentům obsaženým v klimatizačním zařízení musí jeho demontáž provádět odborný instalatér v souladu s platnými předpisy. Více informací lze získat od příslušných orgánů.

## HOIATUS

Seda toodet ei tohi kasutusea lõpus ära visata üldiste olmejäätmete hulka ja see tuleb kõrvaldada kooskõlas asjaomaste kohalike või riiklike eeskirjadega vastavalt keskkonnanõuetele.  
Kuna õhukonditsioneer sisaldab jahutusvedelikku, õli ja muid komponente, tohib seda lahti võtta ainult paigaldusspetsialist vastavuses kohaldatavate eeskirjadega. Lisateabe saamiseks võtta ühendust vastavate ametiasutustega.

## FIGYELMEZTETÉS

Élettartama végén a termék az általános háztartási hulladékkal nem keverendő; ártalmatlanítását a vonatkozó helyi vagy nemzeti előírásoknak megfelelően, környezetvédelmi szempontból helyesen kell végezni.  
A légkondicionálóban található hűtőközeg, olaj és egyéb anyagok miatt ennek szétszerelését a vonatkozó előírásoknak megfelelően, szakembernek kell végeznie. További információért forduljon az illetékes hatósághoz.

## UZMANĪBA

Pēc produkta lietošanas beigām to nedrīkst jautk ar vispārējiem māsaimniecības atkritumiem, un saskaņā ar attiecīgajiem vietējiem vai nacionālajiem noteikumiem tas jālikvidē videi draudzīgā veidā.  
Sakarā ar dzesējošo vielu, eļļu un citām sastāvdaļām, kas atrodas gaisa kondicionētājā, tā demontāža, saskaņā ar piemērojamajiem noteikumiem, jāveic profesionālam uzstādītājam. Sazinieties ar attiecīgajām iestādēm, lai saņemtu plašāku informāciju.

## ĮSPĖJIMAS

Pasibaigus eksploatacijos laikui, šis produktas neturi būti maišomas su buitiniemis atliekomis ir turi būti išmetamas laikantis aplinkosaugos požiūriu tinkamų vietinių ar nacionalinių reglamentų.  
Dėl aušinimo medžiagos, alyvos ir kitų komponentų, esančių oro kondicionieriuje, jo išmontavimą turi atlikti profesionalus montuotojas pagal galiojančias taisykles. Norėdami gauti daugiau informacijos, susisiekite su atitinkamomis institucijomis.

## OSTROŻNIE

Po zakończeniu okresu użytkowania produktu, nie należy go wyrzucać z odpadami komunalnymi, lecz dokonać jego usunięcia w sposób ekologiczny zgodnie z obowiązującymi w tym zakresie przepisami prawa lokalnego lub krajowego.  
Ponieważ klimatyzatory zawierają czynniki chłodnicze i oleje oraz innego rodzaju elementy składowe, ich demontaż należy powierzyć wskazanemu w obowiązujących przepisach specjalistycznemu podmiotowi. Szczegółowe informacje na ten temat można uzyskać, kontaktując się z właściwymi organami władzy samorządowej.

## PRECAUȚIE

Acest produs nu trebuie aruncat la gunoii menajer la sfârșitul duratei sale de viață, ci trebuie scos din uz în conformitate cu reglementările locale sau naționale adecvate și într-un mod corect din punct de vedere al protecției mediului.  
Datorită agentului frigorific, a uleiului și a altor componente ale aparatului de aer condiționat, demontarea acestuia trebuie făcută de un instalator profesionist în conformitate cu reglementările aplicabile. Contactați autoritățile competente pentru mai multe informații.

## ΠΡΕΔΥΠΡΕΞΔΕΝΙΕ

Этот продукт не должен утилизироваться вместе с обычными бытовыми отходами по истечению срока службы, а сдан в экологические пункты сбора в соответствии с местными или национальными нормами.  
Из-за хладагента, масла и других компонентов, содержащихся в кондиционере, его демонтаж должен выполняться профессиональным установщиком в соответствии с действующими правилами. Для получения дополнительной информации свяжитесь с соответствующими органами.

# R32

## English

### WARNING

#### BURST HAZARD

Do not allow air or any gas mixture containing oxygen into refrigerant cycle (i.e. piping)



#### WARNING

This symbol displayed on the unit indicates that this appliance is filled with R32, an odourless flammable refrigerant gas with low burning velocity (A2L class pursuant to ISO 817). If the refrigerant is leaked, there is a possibility of ignition if it enters in contact with an external ignition source.



#### CAUTION

This symbol displayed on the unit indicates that this appliance shall be handled by authorized service personnel only, referring to the Installation Manual.



#### CAUTION

This symbol displayed on the unit indicates that there is relevant information included in the Operation Manual and/or Installation Manual.



#### CAUTION

For more information, see the Installation and Operation Manual.

## Español

### ADVERTENCIA

#### RIESGO DE EXPLOSIÓN

Evite la entrada de aire o cualquier mezcla de gases que contenga oxígeno en el ciclo de refrigerante, por ejemplo, en las tuberías.



#### ADVERTENCIA

Este símbolo mostrado en el aparato indica que este está cargado con R32, un gas refrigerante inflamable e inodoro con una velocidad de combustión lenta (Clase A2L de acuerdo con ISO 817). Una fuga de refrigerante puede provocar un incendio si entra en contacto con una fuente de combustión externa.



#### PRECAUCIÓN

Este símbolo mostrado en el aparato indica que este debe ser manipulado únicamente por personal de un servicio autorizado con el soporte del manual de instalación.



#### PRECAUCIÓN

Este símbolo mostrado en el aparato indica que los manuales de funcionamiento y/o de instalación contienen información importante.



#### PRECAUCIÓN

Para más información, consulte el Manual de Instalación y Funcionamiento.

## Deutsch

### WARNUNG

#### BERSTGEFAHR

Lassen Sie nicht zu, dass Luft oder eine Sauerstoff enthaltene Gas-mischung in den Kältemittelkreislauf (z. B. Rohrleitungen) gelangt.



#### WARNUNG

Dieses auf dem Gerät angezeigte Symbol zeigt an, dass das Gerät ist mit dem R32 geruchlosen brennbaren Kältemittel mit niedriger Brenngeschwindigkeit gefüllt (Klasse A2L gemäß ISO 817). Bei einem Kältemittelaustritt besteht die Gefahr der Entzündung, wenn das Kältemittel in Kontakt mit einer äußeren Zündquelle kommt.



#### VORSICHT

Dieses auf dem Gerät angezeigte Symbol zeigt an, dass dieses Gerät ein entzündbares Kältemittel verwendet. Bei einem Kältemittelaustritt besteht die Gefahr der Entzündung, wenn das Kältemittel in Kontakt mit einer äußeren Zündquelle kommt.



#### VORSICHT

Dieses auf dem Gerät angezeigte Symbol zeigt an, dass wichtige Informationen im Betriebshandbuch und/oder Installationshandbuch enthalten sind.



#### VORSICHT

Weitere Informationen finden Sie in der Installations- und betriebs-handbuch.

## Français

### AVERTISSEMENT

#### DANGER D'ÉCLATEMENT

Évitez que de l'air ou un mélange de gaz contenant de l'oxygène ne pénètre dans le cycle frigorifique (c.-à-d. tuyauterie)



#### AVERTISSEMENT

Ce symbole affiché sur l'appareil indique que l'appareil est chargé avec R32, un gaz frigorigène inflammable sans odeur à basse vitesse de combustion (Classe A2L selon ISO 817). En cas de fuite de frigorigène, il existe un risque d'incendie si celui-ci est exposé à une source d'inflammation externe.



#### ATTENTION

Ce symbole affiché sur l'appareil indique que seul le personnel de maintenance autorisé doit manipuler l'équipement, en se reportant au manuel d'installation.



#### ATTENTION

Ce symbole affiché sur l'appareil indique que le manuel de fonctionnement et/ou le manuel d'installation contient des informations importantes.



#### ATTENTION

Pour plus d'informations, reportez-vous au Manuel d'installation et de fonctionnement.

## Italiano

### AVVERTENZA

#### PERICOLO DI SCOPPIO

Fare in modo che all'interno del ciclo di refrigerazione non entrino aria o qualsiasi miscela di gas contenente ossigeno (per es. le tubazioni).



#### AVVERTENZA

Questo simbolo visualizzato sull'unità indica che l'unità è caricata con R32, un gas refrigerante infiammabile e inodore con una velocità di combustione lenta (Classe A2L secondo ISO 817). Una perdita di refrigerante può provocare un incendio se entra a contatto con una fonte di combustione esterna.



#### AVVERTENZA

Questo simbolo visualizzato sull'unità indica che l'unità deve essere gestita solo da personale di servizio autorizzato, facendo riferimento al Manuale di Installazione.



#### AVVERTENZA

Questo simbolo visualizzato sull'unità indica che ci sono informazioni rilevanti incluse nel Manuale d'uso e/o nel Manuale di Installazione.

# R32



## AVVERTENZA

Per ulteriori informazioni, consultare il Manuale d'installazione e d'uso.

## Português

### ATENÇÃO

#### PERIGO DE REBENTAMENTO

Não permitir a entrada de ar ou de qualquer mistura de gás com oxigénio para o ciclo de refrigeração (isto é, para tubagem).



#### ATENÇÃO

Este símbolo mostrado na unidade indica que a unidade contém R32, um gás refrigerante inflamável e inodoro com uma baixa velocidade de queima (Classe A2L de acordo com ISO 817). Em caso de fuga de refrigerante, existe a possibilidade de ignição se entrar em contacto com uma fonte de ignição externa.



#### CUIDADO

Este símbolo mostrado na unidade indica que a unidade deve ser manuseada apenas por pessoal autorizado, mediante consulta do Manual de Instalação.



#### CUIDADO

Este símbolo mostrado na unidade indica que o Manual de Funcionamento e/ou Instalação inclui informação relevante.



#### CUIDADO

Para mais informação, consulte o Manual de Instalação e de Funcionamento.

## Dansk

### ADVARSEL

#### BRISTEFARE

Lad ikke luft eller en gasblanding, der indeholder ilt, komme ind i kølemiddelcyklussen (dvs. rørføringen)



#### ADVARSEL

Dette symbol vises på enheden angiver, at enheden er fyldt med R32, en brændbar og lugtfri kølemiddelgas med en langsom forbrændingshastighed (klasse A2L i henhold til ISO 817). Udslip af kølemiddel kan forårsage brand, hvis kølemidlet kommer i kontakt med en ekstern antændelseskilde.



#### FORSIGTIG

Dette symbol vises på enheden angiver, at enheden kun skal håndteres af autoriseret servicepersonale under henvisning til installationsmanualen.



#### FORSIGTIG

Dette symbol vises på enheden angiver, at der er relevante oplysninger, der er indeholdt i drifts- og/eller installationsmanualen.



#### FORSIGTIG

For yderligere information se installations- og betjeningsvejledningen.

## Nederlands

### WAARSCHUWING

#### BARSTGEVAAR

Laat geen lucht of een gasmengsel dat zuurstof bevat in de koelmiddelcyclus (d.w.z. leidingen).



## WAARSCHUWING

Dit symbool op het apparaat geeft aan dat het apparaat is gevuld met R32, een geurloos ontvlambaar koelmiddel met een lage brandsnelheid (klasse A2L volgens ISO 817). Als het koelmiddel lekt, kan het ontbranden wanneer het in contact komt met een externe ontstekingsbron.



#### LET OP

Dit symbool op het apparaat geeft aan dat het apparaat alleen door bevoegd personeel mag worden gebruikt, met verwijzing naar de installatiehandleiding.



#### LET OP

Dit symbool op het apparaat geeft aan dat er relevante informatie is opgenomen in de gebruiksaanwijzing en / of installatiehandleiding.



#### LET OP

Meer informatie hierover vindt u in de installatie- en bedieningshandleiding.

## Svenska

### VARNING

#### SPRÄNGRISK

Låt ingen luft eller gasblandning innehållande syra komma in i kylmedelcykeln (t.ex. rörlledning)



#### VARNING

Den här symbolen som visas på enheten indikerar att enheten är fylld med R32, ett luktfritt brandfarligt kylmedel med låg förbränningshastighet (A2L-klass enligt ISO 817). Om kylmedel läcker ut finns det risk för antändning om det kommer i kontakt med en extern antändningskälla.



#### VARNING

Den här symbolen som visas på enheten indikerar att enheten endast får hanteras av auktoriserad servicepersonal och i enlighet med installationsmanualen.



#### VARNING

Den här symbolen som visas på enheten indikerar att användarmanualen/installationsmanualen innehåller viktig information.



#### VARNING

För mer information, se referensguiden för installation- och drift-handbok.

## Ελληνικά

### ΠΡΟΕΙΔΟΠΟΙΗΣΗ

#### ΚΙΝΔΥΝΟΣ ΦΩΤΙΑΣ

Μην επιτρέπετε την είσοδο αέρα ή οποιοδήποτε μείγμα αερίου που περιέχει οξυγόνο στον κύκλο ψυκτικού μέσου (δηλαδή σωλήνωση)



#### ΠΡΟΕΙΔΟΠΟΙΗΣΗ

Αυτό το σύμβολο που εμφανίζεται στη μονάδα δείχνει ότι η μονάδα είναι γεμάτη με R32, ένα άσπρο εύφλεκτο ψυκτικό με χαμηλή ταχύτητα καύσης (κλάση A2L σύμφωνα με το πρότυπο ISO 817). Η διαρροή του ψυκτικού μέσου μπορεί να προκαλέσει πυρκαγιά αν έρθει σε επαφή με ένα εξωτερικό μέσο.



#### ΠΡΟΣΟΧΗ

Αυτό το σύμβολο που εμφανίζεται στη μονάδα δείχνει ότι η μονάδα πρέπει να πραγματοποιείται μόνο από εγκεκριμένο προσωπικό σέρβις σύμφωνα με το εγχειρίδιο εγκατάστασης.



**ΠΡΟΣΟΧΗ**

Αυτό το σύμβολο που εμφανίζεται στη μονάδα δείχνει ότι υπάρχουν σχετικές πληροφορίες στο εγχειρίδιο λειτουργίας και/ή στο εγχειρίδιο εγκατάστασης.

**ΠΡΟΣΟΧΗ**

Για περισσότερες πληροφορίες, ανατρέξτε στο Εγχειρίδιο εγκατάστασης και λειτουργίας.

**Български****ΠΡΕДУΠРЕЖДЕНИЕ****ОПАСНОСТ ОТ ИЗБУХВАНЕ**

В цикъла на хладилния агент (т.е. в тръбите) не бива да се допуска проникването на въздух и каквато и да било друга газова смес.

**ΠΡΕДУΠРЕЖДЕНИЕ**

Този символ, изобразен на изделието, показва, че този уред е запълнен с R32, леснозапалим хладилен газ без мирис и с ниска скорост на горене (клас A2L по ISO 817). Ако хладилният агент протече, възниква възможност от запалване, ако влезе в контакт с външен източник на запалване.

**ВНИМАНИЕ**

Този символ, изобразен на изделието, показва, че с този уред може да работят само упълномощени за тази цел сервизни техници и при спазване указанията от Ръководството за инсталиране.

**ВНИМАНИЕ**

Този символ, изобразен на изделието, показва, че в Ръководството за експлоатация и/или в Ръководството за инсталиране има съответната информация.

**ВНИМАНИЕ**

За повече информация виж Ръководството за инсталиране и експлоатация.

**Čeština****VAROVÁNÍ****NEBEZPEČÍ TŘESKU**

Nedopusťte, aby vzduch či jakákoliv plynná směs obsahující kyslík pronikly do chladivového okruhu (např. potrubí).

**VAROVÁNÍ**

Tento symbol zobrazený na jednotce označuje, že náplň tohoto zařízení je R32, hořlavý chladivový plyn bez zápachu s mírnou hořlavostí (třída A2L podle ISO 817). Pokud chladivo unikne, existuje možnost vznícení, pokud se dojde ke kontaktu s externím zápalným zdrojem.

**POZOR**

Tento symbol zobrazený na jednotce označuje, že podle Návodu k instalaci smí toto zařízení obsluhovat pouze autorizovaný technický personál.

**POZOR**

Tento symbol zobrazený na jednotce označuje, že Návod k obsluze a/nebo v Návodu k instalaci obsahuje relevantní informace.

**POZOR**

Více informací naleznete v Návodu k instalaci a obsluze.

**Eesti****HOIATUS****LÕHKEMISOHT**

Ärge laske jahutussüsteemi (s.o torustikku) õhku või gaasisegu, mis sisaldab hapnikku.

**HOIATUS**

See sümbol seadme peal näitab, et seade on täidetud lõhnatu, tuleohtliku, aeglase põlemiskiirusega jahutusgaasiga R32 (standardi ISO 817 järgi klass A2L). Kui jahutusvahendit lekib, võib see kokkupuutel välise süüteallikaga põlema süttida.

**ETTEVAATUST**

See sümbol seadme peal näitab, et seda seadet tohivad käsitseda ainult volitatud teenindustöötajad, kes lähtuvad paigaldusjuhendist.

**ETTEVAATUST**

See sümbol seadme peal näitab, et vajalikku teavet leiab kasutus- ja/või paigaldusjuhendist.

**ETTEVAATUST**

Lisateavet leiab paigaldus- ja/või kasutusjuhendist.

**Magyar****FIGYELEM****FELSZAKADÁSVESZÉLY**

Ne engedje, hogy a hűtőközegbe (pl. a csővezetékekbe) levegő vagy oxigéntartalmú gázkeverék kerüljön.

**FIGYELEM**

A készüléken megjelenő szimbólum azt jelzi, hogy a berendezés R32 hűtőközeggel van feltöltve, amely egy szagtalan, gyúlékony, alacsony égési sebességű (az ISO 817 szabvány értelmében A2L osztályú) hűtőközeg gáz. A hűtőközeg szivárgása esetén gyulladásveszély áll fenn, amennyiben a hűtőközeg külső gyújtóforrással érintkezik.

**FIGYELMEZTETÉS**

Ez a készüléken megjelenő szimbólum azt jelzi, hogy a berendezést csak felhatalmazott szervizszemélyzet kezelheti, a Telepítési útmutató alapján.

**FIGYELMEZTETÉS**

Ez a készüléken megjelenő szimbólum azt jelzi, hogy az Üzemeltetési útmutató és/vagy a Telepítési útmutató fontos információt tartalmaz az adott kérdésre vonatkozóan.

**FIGYELMEZTETÉS**

További információért lásd a Telepítési és Üzemeltetési útmutatót.

**Latviešu****BRĪDINĀJUMS****ŠALTS RISKS**

Neļaujiet gaisam vai citiem skābekli saturošiem gāzes maisījumiem iekļūt aukstumaģenta ciklā (t.i., caurulēs)

**BRĪDINĀJUMS**

Šis uz ierīces parādītais simbols norāda, ka šī ierīce ir piepildīta ar R32, bez smakas un viegli uzliesmojošu dzesēšanas šķidrums ar zemu sadegšanas ātrumu (A2L klase saskaņā ar ISO 817). Ja aukstumaģents ir noplūdis, pastāv aizdegšanās iespēja, ja tas nonāk saskarē ar ārēju aizdegšanās avotu.

**UZMANĪBU**

Šis uz ierīces redzamais simbols norāda, ka ar šo ierīci drīkst rīkoties tikai pilnvarots servisa personāls, atsaucoties uz uzstādīšanas rokasgrāmatu.

**UZMANĪBU**

Šis uz ierīces redzamais simbols norāda, ka darbības rokasgrāmatā un/vai uzstādīšanas rokasgrāmatā ir iekļauta būtiska informācija.

**UZMANĪBU**

Papildinformāciju skatiet Instalācijas un ekspluatācijas rokasgrāmatā.

**Lietuvių****PERSPĖJIMAS****SPROGIMO PAVOJUS**

Neleiskite, kad į aušinimo ciklą (t. y. vamzdynus) patektų oro ar kitų dujų mišinys, kuriuose yra deguonies.

**PERSPĖJIMAS**

Šis ant elemento rodomas simbolis nurodo, kad šis prietaisas užpildytas R32, bekvapėmis degiomis aušinimo dujomis, turinčiomis mažą degimo greitį (A2L klasė pagal ISO 817). Jei aušinimo medžiaga nutekėjo ir ji liečiasi su išoriniu degimo šaltiniu, kyla užsidegimo galimybė.

**ĮSPĖJIMAS**

Šis ant elemento rodomas simbolis nurodo, kad su šiuo prietaisu gali dirbti tik įgalioti techninės priežiūros darbuotojai, remdamiesi Montavimo vadovu.

**ĮSPĖJIMAS**

Šis ant elemento rodomas simbolis nurodo, kad naudojimo vadove ir (arba) montavimo vadove yra informacijos.

**ĮSPĖJIMAS**

Daugiau informacijos rasite „Montavimo ir naudojimo vadove“.

**Polski****OSTRZEŻENIE****ZAGROŻENIE WYBUCEM**

Niedopuszczalne jest przedostanie się powietrza lub mieszaniny gazowej zawierającej tlen do obiegu (tj. przewodów rurowych) czynnika chłodniczego.

**OSTRZEŻENIE**

Umieszczenie tego symbolu na jednostce oznacza, że jest ona napełniona czynnikiem chłodniczym R32, bezwonnym i palnym gazem o niskiej prędkości spalania (klasa A2L zgodnie z normą ISO 817). Wyciek chłodziwa może spowodować pożar, gdyby doszło do kontaktu z zewnętrznym źródłem zapłonu.

**OSTROŻNIE**

Umieszczenie tego symbolu na jednostce oznacza, że może być ona obsługiwana wyłącznie przez pracowników autoryzowanego serwisu w oparciu o informacje zawarte w Instrukcji instalacji.

**OSTROŻNIE**

Umieszczenie tego symbolu na jednostce oznacza, że w Instrukcji obsługi i/lub Instrukcji instalacji znajdują się ważne informacje na dany temat.

**OSTROŻNIE**

Szczegółowe informacje można znaleźć w Instrukcji instalacji i obsługi.

**Română****AVERTISMENT****PERICOL DE DEFLAGRAȚIE**

Nu permiteți pătrunderea aerului sau oricărui amestec de gaz care conține oxigen în ciclul agentului frigorific (adică în conducte).

**AVERTISMENT**

Această pictogramă afișată pe unitate indică faptul că acest aparat este umplut cu R32, un gaz frigorific inflamabil inodor, cu viteză de ardere redusă (clasa A2L conform standardului ISO 817). Pierderile de agent frigorific pot cauza pericol de aprindere dacă intră în contact cu o sursă de aprindere externă.

**PRECAUȚIE**

Această pictogramă afișată pe unitate indică faptul că acest aparat trebuie să fie manipulat doar de personal de service autorizat, respectându-se instrucțiunile din manualul de instalare.

**PRECAUȚIE**

Această pictogramă afișată pe unitate indică faptul că manualul de operare și/sau manualul de instalare conțin informații importante.

**PRECAUȚIE**

Pentru mai multe informații vă rugăm să consultați manualul de instalare și operare.

**Русский****ПРЕДУПРЕЖДЕНИЕ****ВЗРЫВООПАСНОСТЬ**

Не допускайте попадания воздуха или газовых смесей, содержащих кислород, в цикл охлаждения (т. е. трубопровод)

**ПРЕДУПРЕЖДЕНИЕ**

Этот символ, отображаемый на блоке, указывает на то, что данный прибор заполнен воспламеняющимся хладагентом без запаха R32 с низкой скоростью горения (класс A2L согласно ISO 817). В случае утечки хладагента существует вероятность возгорания при контакте с внешним источником возгорания.

**ВНИМАНИЕ**

Этот символ, отображаемый на блоке, указывает на то, что с этим устройством должен обращаться только авторизованный обслуживающий персонал, ссылаясь на Руководство по установке.

**ВНИМАНИЕ**

Этот символ, отображаемый на блоке, указывает на наличие соответствующей информации, включенной в Руководство по эксплуатации и / или Руководство по установке.

**ВНИМАНИЕ**

Для получения дополнительной информации см. Руководство по установке и эксплуатации.

**English**

**RISK OF EXPLOSION**

*The compressor must be stopped before removing the refrigerant pipes.*

*All service valves must be fully closed after pumping down operation.*

- Make sure that unit installation and refrigerant piping installation comply with applicable legislation in each country. Also, in Europe, EN378 must be complied, as it is the applicable standard.
- The supplementary information about the purchased products is supplied in a CD-ROM, which can be found bundled with the outdoor unit. In case that the CD-ROM is missing or it is not readable, please contact your HITACHI dealer or distributor.
- **PLEASE READ MANUALS AND THE FILES ON THE CD-ROM CAREFULLY BEFORE STARTING WORK ON THE INSTALLATION OF THE AIR CONDITIONING SYSTEM.** Failure to observe the instructions for installation, use and operation described in this documentation may result in operating failure including potentially serious faults, or even the destruction of the air conditioning system.
- Verify, in accordance with the manuals which appear in the outdoor and indoor units, that all the information required for the correct installation of the system is included. If this is not the case, contact your distributor.

Indoor Unit	Outdoor Unit
Installation and operation manual	Installation manual
	CD-ROM
	Additional safety manual for R32 refrigerant air conditioner and heat pump according to IEC 60335-2-40:2018

**Español**

**RIESGO DE EXPLOSIÓN**

*Antes de retirar las tuberías de refrigerante debe detener el compresor.*

*Tras recuperar el refrigerante todas las válvulas de servicio deben estar completamente cerradas*

- Asegúrese de que la instalación de la unidad y de la tubería de refrigerante cumplan con la legislación vigente de cada país. Asimismo, en Europa se debe cumplir la EN378, ya que es la norma aplicable.
- En el CD-ROM que se incluye con la unidad exterior encontrará información adicional acerca del producto adquirido. Si no tiene el CD-ROM o si es ilegible contacte con su proveedor o distribuidor HITACHI.
- **LEA ATENTAMENTE EL MANUAL Y EL CONTENIDO DEL CD-ROM ANTES DE INICIAR LAS TAREAS DE INSTALACIÓN DEL SISTEMA DE AIRE ACONDICIONADO.** El incumplimiento de las instrucciones de instalación, uso y funcionamiento descritas en este documento puede provocar fallos de funcionamiento potencialmente graves, o incluso la destrucción del sistema.
- Compruebe, en los manuales de las unidades interior y exterior, que dispone de toda la información necesaria para la correcta instalación del sistema. Si no es así,

póngase en contacto con su distribuidor.

Unidad interior	Unidad exterior
Manual de Instalación y Funcionamiento	Manual de Instalación
	CD-ROM
	Manual de seguridad adicional para sistemas de aire acondicionado y bomba de calor con refrigerante R32 de acuerdo con la norma IEC 60335-2-40:2018

**Deutsch**

**EXPLOSIONSGEFAHR**

*Der Kompressor muss abgeschaltet werden, bevor die Kältemittelleitungen entfernt werden.*

*Alle Betriebsventile müssen nach dem Abpumpbetrieb vollständig geschlossen sein.*

- Stellen Sie sicher, dass die Anlageninstallation und die Kältemittelleitungsinstallation die anwendbare Gesetzgebung in jedem Land erfüllt. Auch in Europa muss EN378 erfüllt werden, da sie die anwendbare Norm ist.
- Die ergänzenden Informationen zu den erworbenen Produkten werden auf einer CD-ROM bereitgestellt, die im Paket mit dem Außengerät zu finden ist. Falls diese CD-ROM fehlen oder nicht lesbar sein sollte, setzen Sie sich bitte mit Ihrem HITACHI-Händler oder Vertragspartner in Verbindung.
- **LESEN SIE DIE VORLIEGENDE ANLEITUNG UND DIE DATEIEN AUF DER CD-ROM SORGFÄLTIG DURCH, BEVOR SIE MIT DER INSTALLATION DER KLIMAANLAGE BEGINNEN.** Die Nichtbeachtung der in der Produktdokumentation beschriebenen Installations-, Nutzungs- und Betriebshinweise kann nicht nur Funktionsstörungen, sondern auch mehr oder weniger schwere Schäden und im Extremfall sogar einen nicht zu behebbenden Schaden an der Klimaanlage hervorrufen.
- Überprüfen Sie anhand der mit den Außen- und Innengeräten gelieferten Handbüchern, dass alle für die korrekte Installation des Systems erforderlichen Informationen vorhanden sind. Wenn dies nicht der Fall ist, wenden Sie sich an Ihren HITACHI-Händler.

Indoor Unit	Outdoor Unit
Installations- und betriebshandbuch	Installationshandbuch
	CD-ROM
	Zusätzliches Sicherheitshandbuch für eine Klimaanlage und eine Wärmepumpe mit R32-Kältemittel gemäß IEC 60335-2-40:2018

**Français**

**RISQUE D'EXPLOSION**

*Veillez à arrêter le compresseur avant de retirer les tuyauteries frigorifiques.*

*Veillez à fermer complètement toutes les vannes de service après la vidange.*

- Assurez-vous que l'installation des unités et de la tuyauterie frigorifique est conforme aux réglementations en vigueur dans chaque pays. En sachant qu'en Europe les installations doivent

obbligatoriamente soddisfare à la norme EN378.

- Avec le CD-ROM inclus dans le groupe extérieur vous trouverez l'information supplémentaire à propos du produit acquis. Si vous n'avez pas ce CD-ROM où il est illisible contactez avec votre fournisseur ou distributeur HITACHI.
- **VEUILLEZ LIRE LE MANUEL ET LES FICHIERS DU CD-ROM ATTENTIVEMENT AVANT DE COMMENTER LES TRAVAUX D'INSTALLATION DU SYSTÈME DE CONDITIONNEMENT D'AIR.** Le non-respect des instructions d'installation, d'utilisation et de fonctionnement décrites dans le présent document peut entraîner des pannes y compris des défaillances potentiellement graves, ou même la destruction du système de conditionnement d'air.
- Vérifiez, conformément aux instructions des manuels fournis avec les unités intérieures et les groupes extérieurs, que toutes les informations nécessaires à la bonne installation du système vous ont été fournies. Si ce n'est pas le cas, contactez votre distributeur.

Unité intérieure	Unité extérieure
Manuel d'installation et de fonctionnement	Manuel d'installation
	CD-ROM
	Manuel de sécurité supplémentaire pour climatiseur et pompe à chaleur avec réfrigérant R32, conformément à la norme IEC 60335-2-40:2018

**Italiano**

**RISCHIO DI ESPLOSIONE**

*Il compressore deve essere arrestato prima di rimuovere i tubi del refrigerante.*

*Tutte le valvole di servizio devono essere completamente chiuse dopo lo svuotamento della pompa.*

- Assicurarsi che l'installazione dell'unità e quella della linea del refrigerante siano conformi alla legislazione vigente in ciascun paese. Inoltre, in Europa, devono essere conformi alla norma EN378, in quanto è lo standard vigente.
- Le informazioni complete riguardo i prodotti acquistati sono forniti all'interno di un CD-ROM che può essere trovato insieme all'unità esterna. Nel caso in cui il CD-ROM non fosse presente o leggibile, contattare il proprio distributore o rivenditore HITACHI.
- **LEGGERE ATTENTAMENTE IL PRESENTE MANUALE E I FILE CONTENUTI NEL CD-ROM PRIMA DI INIZIARE LE OPERAZIONI DI INSTALLAZIONE DEL SISTEMA DI ARIA CONDIZIONATA.** Il mancato rispetto delle istruzioni di installazione, d'uso e di esercizio descritte nel presente documento potrà provocare errori di funzionamento, inclusi guasti potenzialmente gravi, o perfino la distruzione del sistema di aria condizionata.
- In base ai manuali forniti con le unità interne ed esterne, verificare di disporre di tutte le informazioni necessarie per l'installazione corretta del sistema. In caso contrario, contattare il proprio rivenditore.

Unità interna	Unità esterna
Manuale d'installazione e d'uso	Manuale di installazione
	CD-ROM
	Manuale di sicurezza aggiuntivo per climatizzatore e pompa di calore con refrigerante R32 in conformità con la norma IEC 60335-2-40:2018

**Português**

**RISCO DE EXPLOÇÃO**

*O compressor deve ser desligado antes da remoção dos tubos de refrigerante.*

*As válvulas de manutenção devem estar completamente fechadas depois da eliminação do refrigerante.*

- Certifique-se de que a instalação da unidade e a instalação da tubagem de refrigerante cumprem a legislação aplicável em cada país. Na Europa, a norma EN378 deve ser cumprida, por ser a aplicável.
- A informação suplementar sobre os produtos adquiridos é providenciada num CD-ROM, fornecido juntamente com a unidade exterior. Contacte o seu distribuidor ou revendedor HITACHI, caso o CD-ROM esteja em falta ou seja ilegível.
- **LEIA ATENTAMENTE O MANUAL E OS FICHEIROS NO CD-ROM ANTES DE COMEÇAR A TRABALHAR NA INSTALAÇÃO DO SISTEMA DE AR CONDICIONADO.** A inobservância das instruções de instalação, utilização e funcionamento descritas neste documento pode ter como consequência falhas no funcionamento, incluindo danos potencialmente graves, ou mesmo a destruição do sistema de ar condicionado.
- Verifique, de acordo com os manuais das unidades exterior e interior, que está incluída toda a informação necessária para a instalação correta do sistema. Caso contrário, entre em contacto com o seu distribuidor.

Unidade Interior	Unidade Exterior
Manual de instalação e de funcionamento	Manual de instalação
	CD-ROM
	Manual de segurança adicional para ar condicionado e bomba de calor com refrigerante R32 de acordo com a norma IEC 60335-2-40:2018

**Dansk**

**RISIKO FOR EKSPLOSION**

*Kompressoren skal stoppes, inden kølemiddelrørene fjernes.*

*Alle serviceventiler skal være helt lukkede, når kølemidlet er blevet fjernet.*

- Sørg for, at installationen af enheden og kølemiddelrørene overholder den gældende lov i det pågældende land. I Europa gælder beskyttelsesstandard EN378.
- Alt supplerende informationsmateriale om de anskaffede produkter findes på en CD-ROM, som ligger pakket sammen med udendørsenheden. I tilfælde af, at CD-ROMMEN mangler, eller hvis den ikke er læsbar, bedes du kontakte HITACHIs forhandler eller leverandør.

- **LÆS VENLIGST VEJLEDNINGEN OG FILERNE PÅ CD-ROMMEN GRUNDIGT IGENNEM, FØR DU PÅBEGYNDER INSTALLATIONEN AF KLIMAANLÆGGET.** Manglende overholdelse af anvisningerne vedrørende installation, brug og betjening beskrevet i denne dokumentation kan medføre driftsfejl, alvorlige defekter eller ødelæggelse af klimaanlægget.
- Kontroller, at alle de oplysninger, der er nødvendige for en korrekt montering af systemet, findes i manualerne til indendørs- og udendørsenhederne. Hvis dette ikke er tilfældet, skal du kontakte din distributør.

Indendørs enhed	Udendørs enhed
Installations- og betjeningsvejledning	Installationsmanual
	CD-ROM
	Ekstra sikkerhedsmanual til klimaanlæg og varmepumpe med R32-kølemiddel i henhold til IEC 60335-2-40:2018

**Nederlands**

**EXPLOSIEGEVAAR**

*De compressor moet worden gestopt alvorens de koelmiddel-pijpen te verwijderen.*

*Alle onderhoudskranen moeten volledig gesloten zijn na het pompen.*

- Zorg ervoor dat de installatie van de unit en de leidingen voor het koelmiddel overeenkomen met de wetgeving uit elk land. In Europa moet tevens EN378 overeenkomen gezien het de toepasbare norm is.
- Aanvullende informatie over het gekochte product is beschikbaar op een cd-rom, die wordt meegeleverd met de buitenunit. Als deze cd-rom ontbreekt of niet leesbaar is, neem dan contact op met uw HITACHI-distributeur.
- **LEES DE HANDLEIDING EN DE BESTANDEN OP DE CD-ROM ZORGVULDIG DOOR VOORDAT U AAN DE INSTALLATIE VAN HET AIRCONDITIONINGSSYSTEEM BEGINT.** Als u de instructies voor de installatie, het gebruik en de werking zoals beschreven in deze documentatie niet opvolgt, kan dit leiden tot een slechte werking van het systeem, met inbegrip van ernstige storingen en zelfs de vernieling van het systeem.
- Controleer met behulp van de handleidingen van de buiten- en binnenunits of alle informatie die nodig is voor een juiste installatie van het systeem aanwezig is. Neem contact op met uw distributeur als dit niet het geval is.

Indoor Unit	Outdoor Unit
Installatie-en bedieningshandleiding	Installatiehandleiding
	CD-ROM
	Aanvullende veiligheidsinformatie voor R32 koelmiddel voor airconditioner en warmtepomp in overeenstemming met IEC 60335-2-40:2018

**Svenska**

**RISK FÖR EXPLOSION**

*Kompression måste stängas av innan kylrören avlägsnas.*

*Alla serviceventiler måste stängas av ordentligt efter ned-pumpning.*

- Försäkra att installation av enheten och kylrör uppfyller tillämpliga bestämmelser för varje land. Inom Europa så måste man även uppfylla EN378 som tillämplig standard.
- Ytterligare information om den förvärvade produkten finns på en CD-ROM som medföljer utomhusenheten. Om CD-ROM saknas eller är oläslig, vänligen kontakta er HITACHI-handlare eller återförsäljare.
- **LÄS IGENOM HANDBOKEN NOGGRANT INNAN DU PÅBÖRJAR INSTALLATIONEN AV LUFTKONDITIONSDYSTEMET.** Om inte instruktionerna för installation, användning och drift som beskrivs i denna dokumentation följs kan det leda till driftfel, inklusive eventuellt allvarliga fel, eller till och med att luftkonditioneringssystemet förstörs.
- Kontrollera, enligt handböckerna för inomhus- och utomhusenheterna, att all information som krävs för att utföra installationen av systemet korrekt finns med. Om så inte är fallet kontaktar du distributören.

Inomhusenhet	Utomhusenhet
Installation- och drifthandbok	Installationsmanual
	CD-ROM
	Extra säkerhetsmanual för R32-kylmedium i luftkonditioneringsapparat och varmepump, i enlighet med IEC 60335-2-40:2018

**Ελληνικά**

**ΚΙΝΔΥΝΟΣ ΕΚΡΗΞΗΣ**

*Ο συμπιεστής πρέπει να έχει σταματήσει προτού αφαιρέσετε τους σωλήνες ψυκτικού μέσου.*

*Όλες οι βαλβίδες λειτουργίας πρέπει να είναι πλήρως κλειστές μετά την λειτουργία άντλησης.*

- Βεβαιωθείτε ότι η εγκατάσταση της μονάδας και η εγκατάσταση της σωλήνωσης ψυκτικού μέσου τηρούν την ισχύουσα νομοθεσία της κάθε χώρας. Επίσης, στην Ευρώπη, πρέπει να τηρείται το EN378 καθώς είναι το πρότυπο που ισχύει.
- Όλες οι βοηθητικές πληροφορίες σχετικά με τα προϊόντα που έχετε αγοράσει περιλαμβάνονται στο CD-ROM μαζί με την εξωτερική μονάδα. Σε περίπτωση που δεν υπάρχει το CD-ROM ή δεν είναι αναγνώσιμο, επικοινωνήστε με τον διανομέα ή παροχέα της HITACHI.
- **ΔΙΑΒΑΣΤΕ ΚΑΙ ΕΞΟΙΚΕΙΩΘΕΙΤΕ ΜΕ ΤΟ ΕΓΧΕΙΡΙΔΙΟ ΚΑΙ ΤΑ ΑΡΧΕΙΑ ΤΟΥ CD-ROM ΠΡΟΤΟΥ ΞΕΚΙΝΗΣΕΤΕ ΜΕ ΤΗΝ ΕΓΚΑΤΑΣΤΑΣΗ ΤΟΥ ΣΥΣΤΗΜΑΤΟΣ ΚΛΙΜΑΤΙΣΜΟΥ.** Αν δεν λάβετε υπόψη τις οδηγίες εγκατάστασης, χρήσης και λειτουργίας που περιγράφονται σε αυτή την τεκμηρίωση, μπορεί να προκληθεί σφάλμα λειτουργίας, σημαντικά δυνητικά σφάλματα, ή ακόμη καταστροφή του συστήματος κλιματισμού.

- Βεβαιωθείτε, βάσει των εγχειριδίων των εξωτερικών και εσωτερικών μονάδων, ότι περιλαμβάνονται όλες οι απαιτούμενες πληροφορίες για τη σωστή εγκατάσταση του συστήματος. Αν δεν περιλαμβάνονται, επικοινωνήστε με το διανομέα σας.

Εσωτερική μονάδα	Εξωτερική μονάδα
Εγχειρίδιο Εγκατάστασης Και Λειτουργίας	Οδηγίες εγκατάστασης
	CD-ROM
	Επιπλέον οδηγίες ασφάλειας για ψυκτικό κλιματιστικού R32 και αντλία θέρμανσης σύμφωνα με το IEC 60335-2-40:2018

## Български

### РИСК ОТ ВЗРИВ

*Компресорът трябва да е напълно спрял, преди да се отстраняват тръбите за хладилния агент.*

*Всички обслужващи клапани трябва да са напълно затворени след операцията по изпомпване.*

- Трябва да е сигурно, че монтажът на изделието и монтажът на тръбите за хладилния агент са в съответствие с приложимата нормативна уредба във всяка страна. В Европа задължително се спазва EN378, тъй като същият е приложимият стандарт.
- Допълнителната информация за закупените продукти се предлага на влизач в комплекта CD-ROM, който се намира в един и същи пакет, залепен за външното тяло. В случай че CD-ROM липсва или не може да се чете, свържете се с вашия търговец или дистрибутор на Hitachi.
- ПРЕДИ ЗАПОЧВАНЕ НА РАБОТА ПО МОНТАЖА НА КЛИМАТИЧНАТА ИНСТАЛАЦИЯ Е НЕОБХОДИМО ВНИМАТЕЛНО ДА ПРОЧЕТЕТЕ РЪКОВОДСТВОТА И ДА СЕ ЗАПОЗНАЕТЕ С ФАЙЛОВОТЕ НА CD-ROM.**
- Неспазването на инструкциите по монтажа, употребата и експлоатацията, описани в тази документация, могат да доведат до експлоатационна повреда, включително до потенциално сериозни дефекти и дори до разрушаване на климатичната инсталация.
- Проверете дали цялата информация, необходима за правилния монтаж на инсталацията е включена в ръководствата за вътрешните и външните тела. Ако не е включена, свържете се с вашия дистрибутор.

Вътрешно тяло	Външно тяло
Ръководството за инсталиране и експлоатация	Ръководство за инсталиране
	CD-ROM
	Допълнително ръководство по безопасност при експлоатация на климатична инсталация с хладилен агент R32 и термомопнен агрегат съгласно IEC 60335-2-40:2018

## Čeština

### NEBEZPEČÍ VÝBUCHU

*Kompresor je třeba před odstraněním chladivového potrubí zastavit.*

*Veškeré provozní ventily musí být před odčerpáním zcela uzavřené.*

- Ujistěte se, že instalace jednotky a instalace

chladivového potrubí splňují příslušné národní právní předpisy. Zároveň musí v Evropě splňovat EN378, neboť jde o příslušnou normu.

- Doplňkové informace o zakoupených produktech jsou dodávány na disku CD-ROM, který lze nalézt přiložený k venkovní jednotce. Pokud CD-ROM chybí nebo není čitelný, obraťte se na prodejce nebo distributora společnosti Hitachi.
- NEŽ ZAČNETE S INSTALACÍ KLIMATIZAČNÍHO SYSTÉMU, PŘEČTĚTE SI, PROSÍM, DŮKLADNĚ NÁVODY A SOUBORY NA CD-ROMU.** Nedodržení pokynů pro instalaci, použití a provoz popsaných v této dokumentaci může mít za následek selhání provozu včetně případných vážných poruch nebo dokonce zničení klimatizačního systému.
- Zkontrolujte v souladu s manuály, které jsou součástí venkovní a vnitřní jednotky, zda jsou k dispozici všechny informace potřebné pro správnou instalaci systému. Pokud tomu tak není, kontaktujte svého distributora.

Vnitřní jednotka	Venkovní jednotka
Návod k instalaci a obsluze	Návod k instalaci
	CD-ROM
	Dodatečný bezpečnostní návod pro klimatizační jednotku a tepelné čerpadlo s chladivem R32, v souladu s IEC 60335-2-40:2018

## Eesti

### PLAHVATUSOHT

*Enne jahutustorustiku eemaldamist tuleb kompressor tuleb seisma panna.*

*Pärast väljapumpamistoimingut tuleb kõik hooldusklapid täiesti kinni panna.*

- Veenduge, et seadme paigaldus ja jahutustorustiku paigaldus vastab igas riigis kohaldatavatele õigusaktidele. Euroopas tuleb täita ka standardi EN378 nõudeid, sest see on kohaldatav standard.
- Lisateavet ostetud toodete kohta saab väliseadme külge kinnitatud CD-ROMilt. Kui CD-ROM on kadunud või ei ole loetav, võtke palun ühendust HITACHI edasimüüja või turustajaga.
- PALUN LUGEGE ENNE ÕHUKONDITSIONEERI SÜSTEEMI PAIGALDUSEGA TÖÖTAMIST HOOLIKALT JUHEND JA CD-ROMi FAILID LÄBI.** Käesolevates dokumentides kirjeldatud paigaldus-, kasutus- ja tööjuhendi eiramine võib põhjustada tõrkeid seadme töös, sealhulgas potentsiaalselt ohtlikke rikkeid, või koguni õhukonditsioneerisüsteemi hävitada.
- Kontrollige vastavalt väli- ja siseseadme juurde pandud juhenditele, et kogu süsteemi õigesti paigaldamiseks vajalik teave on olemas. Kui see nii ei ole, võtke ühendust turustajaga.

Siseseade	Väliseade
Paigaldus- ja kasutusjuhend	Paigaldusjuhend
	CD-ROM
	Lisaohutusjuhend R32 jahutusvedelikuga õhukonditsioneer ja soojuspumba kohta vastavalt standardile IEC 60335-2-40:2018

**Magyar**

**ROBBANÁSVESZÉLY**

*A kompresszort a hűtőközeg csővezetékeinek eltávolítása előtt le kell állítani.*

*A szivattyúzás után minden szervizszelepet teljesen el kell zárni.*

- Ellenőrizze, hogy a készülék telepítése és a hűtőközeg csővezetékeinek telepítése megfelel az egyes országokban alkalmazandó jogszabályoknak. Európában emellett az alkalmazandó EN378 szabvány előírásait kell betartani.
- A megvásárolt termékre vonatkozó további információt a kültéri egységhez mellékelt CD-ROM tartalmazza. Hiányzó vagy nem olvasható CD-ROM esetén kérjük, forduljon a Hitachi kereskedőjéhez vagy forgalmazójához.
- **KÉRJÜK, HASZNÁLAT ELŐTT OLVASSA EL AZ ÚTMUTATÓKAT ÉS A CD-ROMON TALÁLHATÓ TUDNIVALÓKAT A LÉGKONDITIONÁLÓ RENDSZER TELEPÍTÉSÉRE VONATKOZÓAN.** Az alábbi dokumentációban foglalt telepítési, használati és üzemeltetési utasítások figyelmen kívül hagyása működési hibát okozhat, beleértve a potenciálisan súlyos hibákat vagy akár a légkondicionáló rendszer tönkretételét is.
- A kültéri és beltéri egységekhez mellékelt útmutatók alapján ellenőrizze, hogy ezek minden információt tartalmaznak a rendszer helyes telepítéséhez. Ellenkező esetben forduljon a forgalmazóhoz.

Beltéri egység	Kültéri egység
Telepítési és Üzemeltetési útmutató	Telepítési útmutató
	CD-ROM
	Kiegészítő biztonsági útmutató az R32 hűtőközeggel működő légkondicionálóhoz és hőszivattyúhoz az IEC 60335-2-40:2018 szabványnak megfelelően

**Latviešu**

**SPRĀDZIENA RISKS**

*Pirms aukstumaģenta cauruļu noņemšanas kompresors jāaptur.*

*Visiem apkopes vārstiem pēc sūkņēšanas ir jābūt pilnībā aizvērtiem.*

- Pārliecinieties, ka ierīces uzstādīšana un aukstumaģenta cauruļvadu uzstādīšana atbilst katrā valstī spēkā esošajiem tiesību aktiem. Arī Eiropā ir jāievēro EN378, jo tas ir piemērojamais standarts.
- Papildu informācija par iegādātajiem produktiem tiek piegādāta kompaktdiskā, kuru var atrast komplektā ar āra ierīci. Ja kompaktdisks ir pazudis vai tas nav nolasāms, lūdzu, sazinieties ar savu Hitachi izplatītāju vai izplatītāju.
- **LŪDZU, RŪPĪGI IZLASIET ROKASGRĀMATAS UN KOMPAKTDISKA FAILUS, PIRMS UZSĀKAT GAISA KONDITIONĒŠANAS SISTĒMAS UZSTĀDĪŠANAS DARBU.** Šajā dokumentācijā aprakstīto uzstādīšanas, izmantošanas un ekspluatācijas instrukciju neievērošanas gadījumā var rasties darbības

traucējumi, ieskaitot potenciāli nopietnus defektus vai pat gaisa kondicionēšanas sistēmas iznīcināšanu.

- Saskaņā ar rokasgrāmatām, kas iekļautas āra un iekštelpu ierīču komplektā, pārbaudiet, vai ir iekļauta visa informācija, kas nepieciešama sistēmas pareizai uzstādīšanai. Ja tas tā nav, sazinieties ar izplatītāju.

Iekštelpu ierīce	Āra ierīce
Uzstādīšanas un lietošanas rokasgrāmata	Uzstādīšanas rokasgrāmata
	CD-ROM
	Papildu drošības rokasgrāmata R32 aukstumaģentam gaisa kondicionierim un siltumsūkņim saskaņā ar IEC 60335-2-40:2018

**Lietuviškai**

**SPROGIMO RIZIKA**

*Prieš ištuštinant aušinimo medžiagos vamzdžius turi būti sustabdytas kompresorius.*

*Išsiurbus visi eksploatavimo vožtuvai turi būti visiškai uždaryti.*

- Įsitinkite, kad elemento ir aušinimo vamzdynų montavimo atitinka kiekvienoje šalyje galiojančius įstatymus. Be to, Europoje turi būti laikomasi EN378, nes tai yra taikomas standartas.
- Papildoma informacija apie įsigytus produktus pateikiama kompaktiniame diske, kurį galima rasti kartu su išoriniu elementu. Jei trūksta kompaktinio disko arba jo negalima perskaityti, kreipkitės į savo Hitachi atstovą arba platintoją.
- **ATIDŽIAI PERSKAITYKITE VADOVUS IR RINKMENAS KOMPAKTINIUOSE DISKUOSE PRIEŠ PRADĖDAMI DARBUS, SUSIJUSIUS SU ORO KONDITIONAVIMO SISTEMOS MONTAVIMU.** Šiuose dokumentuose aprašytą montavimo, naudojimo ir eksploatavimo instrukcijų nesilaikymas gali sukelti triktį, įskaitant galimus rimtus sutrikimus ar netgi oro visišką kondicionavimo sistemos sugadinimą.
- Pagal išorinio ir vidinio elementų vadovus patikrinkite, ar pateikta visa informacija, reikalinga tinkamam sistemos sumontavimui. Jei taip nėra, kreipkitės į platintoją.

Vidinis elementas	Išorinis elementas
Montavimo ir naudojimo vadovas	Montavimo vadovas
	Kompaktinis diskas
	Papildomas R32 aušinimo skysčio oro kondicionieriui ir šilumos siurbliui saugos vadovas pagal IEC 60335-2-40:2018

**Polski**

**RZYKO WYBUCHU**

*Przed odłączeniem przewodów rurowych czynnika chłodniczego należy wyłączyć sprzężarkę.*

*Po odzyskaniu chłodziwa, niezbędne jest całkowite zamknięcie wszystkich zaworów serwisowych.*

- Należy upewnić się, że montaż jednostki i przewodów rurowych czynnika chłodniczego spełnia przepisy

prawne obowiązujące w danym kraju. Ponadto w Europie wymagane jest przestrzeganie normy EN378, która stanowi obowiązujący standard.

- Dodatkowe informacje o nabytym produkcie znajdują się na płycie CD-ROM, która została dołączona do jednostki zewnętrznej. Jeżeli w komplecie brakuje tej płyty lub nie jest możliwe jej odczytanie, prosimy o skontaktowanie się z przedstawicielem handlowym lub dystrybutorem firmy Hitachi.
- **PRZED PRZYSTĄPIENIEM DO MONTAŻU INSTALACJI KLIMATYZACYJNEJ, NALEŻY ZAPOZNAĆ SIĘ TREŚCIĄ NINIEJSZEJ INSTRUKCJI ORAZ ZAWARTOŚCIĄ DOŁĄCZONEJ PŁYTY CD-ROM.** Nieprzestrzeganie prezentowanych tutaj zaleceń, dotyczących montażu, użytkowania i obsługi urządzeń, grozi ich awarią, włącznie z potencjalnie niebezpiecznymi awariami, a nawet zniszczeniem instalacji klimatyzacyjnej.
- Należy upewnić się, że instrukcje instalacji i obsługi jednostek wewnętrznych i zewnętrznych klimatyzatorów zawierają wszelkie niezbędne zalecenia odnoszące się do prawidłowego wykonania związanych z instalacją czynności montażowych. Gdyby tak nie było, należy skontaktować się z dystrybutorem.

Jednostka wewnętrzna	Jednostka zewnętrzna
Instrukcja instalacji i obsługi	Instrukcja instalacji
	Płyta CD-ROM
	Dodatkowa instrukcja bezpieczeństwa, dotycząca klimatyzatorów i pomp ciepła z czynnikiem chłodniczym R32, zgodna z normą IEC 60335-2-40:2018

**Română**

**RISC DE EXPLOZIE**

*Trebuie să opriți compresorul înainte de a decupla conductele de agent frigorific.*

*Toate supapele de serviciu trebuie să fie complet închise după finalizarea operației de evacuare a agentului frigorific.*

- Asigurați-vă că instalarea unității și a conductei de agent frigorific respectă legislația națională aplicabilă. În Europa trebuie respectat și standardul EN378.
- Informații suplimentare despre produsele achiziționate sunt furnizate pe un CD-ROM, care poate fi găsit împreună cu unitatea exterioară. În cazul în care CD-ROM-ul lipsește sau nu poate fi citit, contactați distribuitorul sau centrul autorizat Hitachi.
- **VĂ RUGĂM CITIȚI CU ATENȚIE MANUALELE ȘI FIȘIERELE DE PE CD-ROM ÎNAINTE DE A ÎNCEPE SĂ LUCRAȚI LA INSTALAREA SISTEMULUI DE AER CONDIȚIONAT.** Nerespectarea instrucțiunilor de instalare, utilizare și operare descrise în această documentație poate conduce la defecțiuni de funcționare, inclusiv la defecțiuni potențial grave sau

chiar la distrugerea sistemului de aer condiționat.

- Verificați, în conformitate cu manualele care apar în unitățile exterioare și interioare, că sunt incluse toate informațiile necesare pentru instalarea corectă a sistemului. În caz contrar, contactați distribuitorul.

Unitate interioară	Unitate exterioară
Manual de instalare și operare	Manual de instalare
	CD-ROM
	Manual de siguranță suplimentar pentru aparatul de aer condiționat cu agent frigorific R32 și pompă de căldură conform IEC 60335-2-40:2018

**Русский**

**РИСК ВЗРЫВА**

*Перед снятием труб для циркуляции хладагента компрессор должен быть остановлен.*

*После откачки все сервисные клапаны должны быть полностью закрыты.*

- Убедитесь, что установка блока и трубопровода хладагента выполнены в соответствии с действующим законодательством в каждой стране. Помимо этого, в Европе необходимо соблюдать норму EN378, которая является применимым стандартом.
- Дополнительная информация о приобретенных продуктах поставляется на компакт-диске, который можно найти в комплекте с наружным блоком. Если компакт-диск отсутствует или он не читается, обратитесь к дилеру или дистрибьютору Hitachi.
- **ВНИМАТЕЛЬНО ПРОЧИТАЙТЕ РУКОВОДСТВА И ФАЙЛЫ НА КОМПАКТ-ДИСКЕ ПЕРЕД НАЧАЛОМ РАБОТЫ ПО УСТАНОВКЕ СИСТЕМЫ КОНДИЦИОНИРОВАНИЯ ВОЗДУХА.** Несоблюдение инструкций по установке, применению и эксплуатации, описанных в этой документации, может привести к сбоям в работе, включая потенциально серьезные неисправности или даже повреждение системы кондиционирования.
- Убедитесь, что в руководствах, прилагаемых к наружным и внутренним блокам, содержится вся информация, необходимая для правильной установки системы. Если это не так, обратитесь к своему дистрибьютору.

Внутренний блок	Наружный блок
Руководство по установке и эксплуатации	Руководство по установке
	Компакт-диск
	Дополнительное руководство по безопасности для хладагента R32 для кондиционера и теплового насоса в соответствии с IEC 60335-2-40:2018



**English****R32 Refrigerant circuit**

The unit installation and refrigerant piping should comply with the relevant local and national regulations for the designed refrigerant.

Due to R32 refrigerant and depending on final refrigerant charge amount, a minimum floor area for installation must be considered.

- If total refrigerant charge amount <1.84kg, there are no additional minimum floor area requirements.
- If total refrigerant charge amount  $\geq 1.84$ kg, there are additional minimum floor area requirements to be checked.

**◆ Minimum area requirements**

In case of total refrigerant amount  $\geq 1.84$  kg, the unit should be installed, operated and stored in a room with a floor area larger than the minimum criteria. Use following graphic and table to determine these minimum criteria.

** NOTE**

*In case of not achieving the minimum floor area, contact with your dealer.*

*For further information about refrigerant charge refer to the Outdoor Unit Installation Manual.*

**Español****Circuito de refrigerante R32**

La instalación de la unidad y de la tubería de refrigerante debe cumplir con las normativas locales y nacionales relevantes específicas para el refrigerante.

Por el uso de refrigerante R32 y en función de la carga de refrigerante final, se debe tener en cuenta una área de suelo mínima para la instalación.

- Si la cantidad total de carga de refrigerante <1,84 kg, no se aplican requerimientos de área de suelo mínima adicionales.
- Si la cantidad total de carga de refrigerante  $\geq 1,84$  kg, hay que comprobar los requerimientos de área de suelo mínima adicionales.

**◆ Requerimientos de área mínima**

En caso de que la cantidad total de refrigerante  $\geq 1,84$  kg, la unidad se debería instalar, poner en funcionamiento y almacenar en un espacio con una área de suelo mayor que la de los criterios mínimos: Utilice la tabla y el gráfico que hay a continuación para determinar dichos criterios mínimos.

** NOTA**

*En caso de no disponer del área de suelo mínima, contacte con su proveedor.*

*Para más información sobre la carga de refrigerante, consulte el manual de instalación de la unidad exterior.*

**Deutsch****R32 Kältemittelkreislauf**

Die Anlageninstallation und die Kältemittelleitungen müssen die entsprechenden lokalen und nationalen Vorschriften für das konzipierte Kältemittel einhalten.

Wegen des Kältemittels R32 und abhängig von der endgültigen Kältemittelmenge, muss eine Mindestbodenfläche für die Installation berücksichtigt werden.

- Wenn die Gesamtkältemittelmenge <1,84 kg beträgt, gibt es keine zusätzlichen Anforderungen an die Mindestbodenfläche.
- Wenn die Gesamtkältemittelmenge  $\geq 1,84$  kg beträgt, gibt es zusätzliche Anforderungen an die Mindestbodenfläche, die geprüft werden müssen.

**◆ Mindestflächenanforderungen**

Falls die Gesamtkältemittelmenge  $\geq 1,84$  kg ist, muss die Anlage in einen Raum mit einer Bodenfläche größer als das Mindestkriterium installiert, betrieben und aufgestellt werden. Benutzen Sie die folgende Grafik und Tabelle, um dieses Mindestkriterium zu bestimmen.

** HINWEIS**

*Falls die Mindestbodenfläche nicht erzielt werden kann, kontaktieren Sie Ihren Händler.*

*Weitere Informationen über die Kältemittelmenge finden Sie im Installationshandbuch des Außengeräts*

**Français****Circuit du frigorigène R32**

L'installation des unités et de la tuyauterie frigorifique doit satisfaire aux réglementations locales et nationales pertinentes relatives au frigorigène utilisé.

En raison du frigorigène R32 et de la quantité finale de charge de frigorigène, il est nécessaire lors de l'installation de prévoir une surface au sol minimale.

- Si le quantité totale de charge de fluide frigorigène est <1,84 kg, il n'est alors pas nécessaire de tenir compte des exigences de surface au sol minimale.
- Si le quantité totale de charge de fluide frigorigène est  $\geq 1,84$  kg, il est nécessaire de prévoir une surface au sol minimale.

**◆ Exigences de surface minimale**

Si la quantité de frigorigène totale est  $\geq 1,84$  kg, l'unité doit alors être installée, utilisée et conservée dans une pièce dont la surface au sol est supérieure à la valeur minimale exigée. Reportez-vous aux graphiques suivants pour déterminer cette valeur minimale.

** REMARQUE**

*S'il s'avère impossible de satisfaire à la surface au sol minimale requise, veuillez contacter votre fournisseur.*

*Pour de plus amples informations sur les travaux de charge de fluide frigorigène, consultez le Manuel d'installation du groupe extérieur.*

**Italiano****Circuito del refrigerante R32**

L'installazione dell'unità e quella della linea del refrigerante devono essere conformi alle normative locali e nazionali relative al refrigerante progettato.

A causa del refrigerante R32 e in base alla quantità finale di carica di refrigerante, deve essere considerata una superficie minima di pavimento per l'installazione.

- Se la quantità totale di carica di refrigerante è <1,84 kg, non ci sono ulteriori requisiti di superficie minima per il pavimento.
- Se la quantità totale di carica di refrigerante è ≥1,84 kg, devono essere verificati ulteriori requisiti di superficie minima per il pavimento.

**◆ Requisiti di superficie minima**

Se la quantità totale di refrigerante è ≥1,84 kg, l'unità deve essere installata, utilizzata e conservata in una stanza con una superficie maggiore rispetto ai requisiti minimi. Fare riferimento al grafico e alla tabella di seguito riportati per determinare i requisiti minimi.

 **NOTA**

Se non si raggiunge la superficie minima, contattare il rivenditore. Per ulteriori informazioni sulla carica di refrigerante consultare il Manuale di installazione dell'unità esterna.

**Português****Circuito de refrigerante R32**

A instalação da unidade e a tubagem de refrigerante devem cumprir os regulamentos nacionais e locais para o refrigerante designado.

Devido ao refrigerante R32 e dependendo da quantidade de carga de refrigerante final, deve ser considerada uma área de piso mínima para a instalação.

- Se a quantidade de carga de refrigerante total for <1,84 kg, não existem requisitos adicionais de área de piso mínima.
- Se a quantidade de carga de refrigerante total for ≥1,84 kg, existem requisitos adicionais de área de piso mínima a cumprir.

**◆ Requisitos de área mínima**

Se a quantidade de refrigerante total for ≥1,84 kg, a unidade deve ser instalada, funcionar e ser guardada numa divisão com uma área de piso maior que os critérios mínimos. Utilize o seguinte gráfico e tabela para determinar estes critérios mínimos.

 **NOTA**

Se não atingir a área de piso mínima, contacte o seu distribuidor. Para mais informação sobre as tarefas de carga de refrigerante, consulte o Manual de instalação da unidade exterior.

**Dansk****R32 Kølemiddelkredsløb**

Installationen af enheden og af kølemiddelrørene skal overholde alle relevante lokale og nationale forskrifter for det pågældende kølemiddel.

Som følge af R32 og afhængig af den endelige mængde af kølemiddel påfyldt, skal installationen have et mindste gulvareal.

- Hvis samlet mængde af påfyldt kølemiddel er <1,84 kg, kræves der ikke noget ekstra gulvareal.
- Hvis samlet mængde af påfyldt kølemiddel er ≥1,84 kg, skal krav til ekstra gulvareal tages i betragtning.

**◆ Krav til mindsterareal**

Hvis den samlede mængde af kølemiddel er ≥1,84 kg, skal enheden installeres, betjenes og opbevares i et rum med et gulvareal, der er større end minimumskriterierne. Brug følgende diagram og tavle for at bestemme disse minimumskriterier.

 **BEMÆRK**

Hvis mindste gulvareal ikke kan overholdes, skal du kontakte din forhandler.

Yderligere information om påfyldning af kølemiddel findes i Installationsvejledning til udendørsenheden.

**Nederlands****R32 Koelmiddelcircuit**

De installatie van de unit en de koelmiddelleidingen moeten zich aan de lokale en nationale wetgeving voor het gewenste koelmiddel toepassen.

Gezien het R32 koelmiddel en afhankelijk van de uiteindelijke hoeveelheid koelmiddel, moet er rekening worden gehouden met een minimale vloeroppervlakte voor de installatie.

- Als de totale hoeveelheid koelmiddel <1,84 kg is dan is er geen extra minimale vloeroppervlakte vereist.
- Als de totale hoeveelheid koelmiddel ≥1,84 kg is dan moet de vereiste extra minimale vloeroppervlakte worden geverifieerd.

**◆ Minimale oppervlakte vereiste**

In het geval de hoeveelheid totale koelmiddel ≥1,84 kg moet de unit in een kamer worden geïnstalleerd, gebruikt en opgeborgen met een grotere oppervlakte dan de minimale criteria. Raadpleeg de hieronder aangegeven grafiek en tabel om deze minimale vereiste te bepalen.

 **OPMERKING**

Raadpleeg uw leverancier wanneer u niet aan de vereiste minimale vloeroppervlakte voldoet.

Voor meer informatie over het bijvullen van koudemiddel raadpleegt u de installatiehandleiding van de buitenunit.

**Svenska****R32 Kylkrets**

Installationen av enhet och kylrör måste uppfylla alla relevanta lokala och nationella bestämmelser för det avsedda kylmedlet.

På grund av kylmedlet R32 och beroende på slutlig mängd kylmedel, så måste en minsta golvyta för installation beaktas.

- Om den totala mängden kylmedel understiger 1,84 kg så krävs ingen ytterligare minsta golvyta.
- Om den totala mängden kylmedel uppnår eller överstiger 1,84 kg så den minsta golvytan kontrolleras.

**◆ Krav på minsta yta**

Vid en total mängd kylmedel  $\geq 1,84$  kg, så ska enheten installeras, köras och förvaras i ett rum med en golvyta som överstiger minimikravet. Använd följande grafik och tabell för att fastställa dessa minimikrav:



*Om du inte kan uppnå den minsta golvytan, kontakta din återförsäljare.*

*För mer information om påfyllning av kylmedium, se utomhusenhets Installationshandbok.*

**Ελληνικά****R32 Κύκλωμα ψυκτικού**

Η εγκατάσταση της μονάδας και η σωλήνωση ψυκτικού πρέπει να τηρεί τον σχετικό κώδικα και τους εθνικούς κανονισμούς για το ψυκτικό που προορίζεται.

Λόγω του ψυκτικού R32 και ανάλογα την τελική ποσότητα πλήρωσης με ψυκτικό μέσο, πρέπει να λάβετε υπόψη μία ελάχιστη επιφάνεια δαπέδου.

- Αν η συνολική ποσότητα πλήρωσης με ψυκτικό μέσο  $< 1,84$  kg, δεν υπάρχουν επιπλέον απαιτήσεις για ελάχιστη επιφάνεια δαπέδου.
- Αν η συνολική ποσότητα πλήρωσης με ψυκτικό μέσο  $\geq 1,84$  kg, δεν υπάρχουν επιπλέον απαιτήσεις για ελάχιστη επιφάνεια δαπέδου που πρέπει να ελέγξετε.

**◆ Απαιτήσεις για ελάχιστη επιφάνεια**

Σε περίπτωση που η συνολική ποσότητα πλήρωσης με ψυκτικό μέσο  $\geq 1,84$  kg, η μονάδα πρέπει να εγκατασταθεί, να λειτουργεί και να αποθηκεύεται σε ένα δωμάτιο με επιφάνεια δαπέδου μεγαλύτερη από το ελάχιστο κριτήριο. Χρησιμοποιήστε το παρακάτω γραφικό και τον πίνακα για να προσδιορίσετε αυτά τα ελάχιστα κριτήρια.



*Σε περίπτωση που δεν υπάρχει η ελάχιστη επιφάνεια δαπέδου, επικοινωνήστε με τον προμηθευτή σας.*

*Για περισσότερες πληροφορίες σχετικά με την πλήρωση με ψυκτικό μέσο ανατρέξτε στο εγχειρίδιο εγκατάστασης της εξωτερικής μονάδας.*

**Български****Κρѳг на хладилния агент R32**

Монтажът на изделието и трѳбите за хладилния агент следва да съответстват на съответните разпоредби в страната, отнасящи се за предназначения за изделието хладилен агент.

Минималната площ за монтажа трябва да се съобрази с хладилния агент R32 и с крайното количество хладилен заряд.

- Ако общото количество хладилен заряд  $< 1,84$  kg, към минималната площ за монтажа няма допълнителни изисквания.
- Ако общото количество хладилен заряд  $\geq 1,84$  kg, трябва да се провери какви допълнителни изисквания има към минималната площ за монтажа.

**◆ Изисквания към минималната площ**

Ако общото количество хладилен заряд  $\geq 1,84$  kg, изделието следва да се монтира, експлоатира и съхранява в помещение с подова площ, по-голяма от минималните критерии. За определяне на тези минимални критерии се използват следните графика и таблица.



*В случай че не се получава минималната подова площ е необходимо да се свържете с продавача.*

*Допълнителни справки за хладилния заряд могат да се правят в Ръководството за инсталиране на външното тяло.*

**Čeština****Chladivový okruh R32**

Instalace jednotky a chladivového potrubí musí splňovat příslušné místní a národní předpisy týkající se určeného chladiva.

S ohledem na chladivo R32 a podle konečného množství chladivové náplně je třeba počítat s minimální rozlohou instalační plochy.

- Pokud je celkové množství chladivové náplně  $< 1,84$  kg, nevztahují se na minimální rozlohu instalační plochy žádné dodatečné požadavky.
- Pokud je celkové množství chladivové náplně  $\geq 1,84$  kg, je třeba přihlídnout k dodatečným požadavkům týkajících se minimální rozlohy instalační plochy.

**◆ Požadavky na minimální plochu**

Pokud je celkové množství chladivové náplně  $\geq 1,84$  kg, musí být se jednotka instalovat, provozovat a skladovat v místnosti o rozloze větší stanovní minimální kritéria. K určení tohoto minimálního kritéria použijte následující graf a tabulku.



*Pokud nespĺňujete požadavky na minimální plochu, kontaktujte svého prodejce.*

Více informací o chladivové náplni naleznete v Návodu k instalaci venkovní jednotky.

A hűtőközeg mennyiségére vonatkozó további információkért lásd a kültéri egység Telepítési útmutatóját.

## Eesti

### R32 Jahutussüsteem

Seadme paigaldus ja jahutustorustik peab olema vastavuses ette nähtud jahutusvahendile kehtivate asjakohaste kohalike ja üleriigiliste eeskirjadega.

Jahutusvahendi R32 tõttu ja olenevalt lõplikust jahutusvahendi täitekogusest tuleb arvestada paigaldamiseks vajaliku minimaalse pindala nõudega.

- Kui kogu jahutusvahendi täitekogus on väiksem kui <math><1,84\text{ kg}</math>, siis täiendavaid minimaalse pörandapinna nõudeid ei ole.
- Kui kogu jahutusvahendi täitekogus on suurem kui või võrdne  $\geq 1,84\text{ kg}$ , siis tuleb kontrollida täiendavaid minimaalse pörandapinna nõudeid.

#### ◆ Minimaalne pindala nõuded

Kui jahutusvahendi kogus kokku on  $\geq 1,84\text{ kg}$ , tuleb seade paigaldada, seadmega töötada ja seadet hoida ruumis, mille pöranda pindala on minimaalsest nõutavast pindalast suurem. Nende miinimumnõuete kindlaks määramiseks kasutage järgmist graafikut ja tabelit.



#### MÄRKUS

Kui minimaalse pörandapinna nõuet ei saa täita, võtke ühendust edasimüüjaga.

Lisateavet jahutusvahendi täitekoguse kohta leiab väliseadme paigaldusjuhendist.

## Magyar

### R32 Hűtőközegkör

A készülék telepítésének és a hűtőközeg csővezetékeinek meg kell felelniük a tervezett hűtőközegre vonatkozó helyi és nemzeti szabályozásoknak.

Az R32 hűtőközegből adódóan és a betöltött hűtőközeg végleges mennyiségétől függően minimális telepítési alapterülettel kell számolni.

- Ha a betöltött hűtőközeg összmennyisége  $< 1,84\text{ kg}$ , akkor nincs további minimális alapterület-követelmény.
- Ha a betöltött hűtőközeg összmennyisége  $\geq 1,84\text{ kg}$ , akkor további minimális alapterület-követelményeket kell szem előtt tartani.

#### ◆ Minimális alapterület-követelmények

Ha a betöltött hűtőközeg összmennyisége  $\geq 1,84\text{ kg}$ , a készüléket a minimálisnál nagyobb alapterületű helyiségben kell telepíteni, üzemeltetni és tárolni. Ezeket a minimális követelményeket az alábbi ábra és táblázat segítségével kell meghatározni.



#### MEGJEGYZÉS

Ha a helyiség területe a minimális alapterületnél kisebb, forduljon a forgalmazóhoz.

## Latviešu

### R32 Aukstumaģenta kontūrs

Ierīces uzstādīšanai un aukstumaģenta cauruļvadiem jāatbilst attiecīgajiem vietējiem un nacionālajiem noteikumiem par projektēto aukstumaģentu.

Sakarā ar R32 aukstumaģenta daudzumu un atkarībā no aukstumaģenta galīgās uzlādes daudzuma, ir jāņem vērā minimālā grīdas platība uzstādīšanai.

- Ja kopējais aukstumaģenta uzlādes daudzums ir  $< 1,84\text{ kg}$ , papildu minimālās grīdas platības prasības nav noteiktas.
- Ja kopējais aukstumaģenta uzlādes daudzums ir  $\geq 1,84\text{ kg}$ , ir jāpārbauda arī papildu minimālās grīdas platības prasības.

#### ◆ Minimālās platības prasības

Ja kopējais aukstumaģenta daudzums ir  $\geq 1,84\text{ kg}$ , ierīce jāuzstāda, jādarbina un jāuzglabā telpā, kuras grīdas platība ir lielāka par minimālajiem kritērijiem. Izmantojiet šo grafiku un tabulu, lai noteiktu šos minimālos kritērijus.



#### PIEZĪME

Ja netiek sasniegta minimālā grīdas platība, sazinieties ar izplatītāju. Papildinformācijai par aukstumaģenta uzlādi skatiet "Āra ierīces uzstādīšanas rokasgrāmatu".

## Lietuviškai

### R32 aušinimo grandinė

Elemento montavimas ir aušinimo vamzdynai turi atitikti galiojančius vietinius ir nacionalinius reikalavimus, keliamus suprojektuotai aušinimo medžiagai.

Dėl R32 aušinimo medžiagos ir priklausomai nuo galutinio aušinimo medžiagos kiekio, reikia atsižvelgti į mažiausią grindų plotą montavimui.

- Jei bendras aušinimo medžiagos užpildymo kiekis yra  $< 1,84\text{ kg}$ , papildomi mažiausio grindų ploto reikalavimai nekeliama.
- Jei bendras aušinimo medžiagos užpildymo kiekis yra  $\geq 1,84\text{ kg}$ , reikia patikrinti ir papildomus mažiausio grindų ploto reikalavimus.

#### ◆ Minimalūs ploto reikalavimai

Jei bendras aušinimo medžiagos kiekis yra  $\geq 1,84\text{ kg}$ , elementą reikia sumontuoti, naudoti ir laikyti patalpoje, kurios grindų plotas didesnis nei minimalūs kriterijai. Norėdami nustatyti šiuos minimalius kriterijus, naudokite toliau pateiktą grafiką ir lentelę.



#### PASTABA

Jei neturima mažiausio grindų ploto, susisieki su pardavėju. Daugiau informacijos apie aušinimo medžiagos užpildymą rasite išorinio elemento Montavimo vadove.

**Polski****Obieg czynnika chłodniczego R32**

Montaż jednostki i przewodów rurowych czynnika chłodniczego powinien spełniać obowiązujące w odniesieniu do niego lokalne i krajowe przepisy.

Uwzględniając zastosowanie czynnika chłodniczego R32 i łączną ilość zładu w instalacji, niezbędne jest zapewnienie minimalnej powierzchni podłogi.

- Jeżeli całkowita ilość czynnika chłodniczego <1,84 kg, przestrzeganie zaleceń dotyczących minimalnej powierzchni podłogi nie jest konieczne.
- Jeżeli całkowita ilość czynnika chłodniczego ≥1,84 kg, istnieją dodatkowe wymagania w tym zakresie, które należy uwzględnić.

**◆ Minimalna wymagana powierzchnia**

W przypadku całkowitej ilości czynnika chłodniczego ≥1,84 kg, instalacja oraz działanie i przechowywanie jednostki jest możliwe wyłącznie w pomieszczeniu o powierzchni podłogi zgodnej z przyjętymi minimalnymi kryteriami w tym zakresie. W oparciu o zamieszczoną poniżej tabelę i wykres można określić, czy kryteria te są spełnione.

**UWAGA**

*W przypadku niedysponowania minimalną powierzchnią podłogi, należy skontaktować się ze sprzedawcą.*

*Dodatkowe informacje na temat zładu czynnika chłodniczego można znaleźć w Instrukcji instalacji jednostki zewnętrznej.*

**Română****Circuitul de agent frigorific R32**

Instalarea unității și a conductelor de agent frigorific trebuie să respecte reglementările locale și naționale relevante pentru agentul frigorific stabilit.

Datorită folosirii agentului frigorific R32 și în funcție de cantitatea finală de agent frigorific încărcată, trebuie asigurată o suprafață de instalare minimă.

- În cazul în care cantitatea de agent frigorific încărcată <1,84 kg, nu există cerințe suplimentare de spațiu minim.
- În cazul în care cantitatea de agent frigorific încărcată ≥1,84 kg, există cerințe suplimentare de spațiu minim care trebuie verificate.

**◆ Cerințe de spațiu minim**

În cazul în care cantitatea de agent frigorific încărcată ≥1,84 kg, unitatea trebuie instalată, operată și depozitată într-o încăpere cu un spațiu mai mare decât cea specificată în criteriul minim. Consultați graficul și tabelul de mai jos pentru a determina acest criteriu minim.

**NOTĂ**

*Dacă nu dispuneți de spațiul minim, contactați distribuitorul.*

*Pentru mai multe informații despre încărcarea agentului frigorific, consultați manualul de instalare a unității exterioare.*

**Русский****Контур хладагента R32**

Установка блока и трубопровода хладагента должны соответствовать местным и национальным нормам для применяемого хладагента.

Принимая во внимание использование хладагента R32, и в зависимости от конечного количества хладагента для зарядки системы, необходимо учитывать минимальную площадь пола для установки.

- Если общее количество хладагента для зарядки системы <1,84 кг, то нет необходимости применять дополнительные требования к минимальной площади пола.
- Если общее количество хладагента для зарядки системы ≥1,84 кг, то следует проверить необходимость применить дополнительные требования к минимальной площади пола.

**◆ Требования к минимальной площади пола**

В случае если общее количество хладагента для зарядки системы ≥1,84 кг, блок следует устанавливать, эксплуатировать и хранить в помещении с площадью пола, превышающей минимальные размеры. Используйте следующий график и таблицу, чтобы определить эти минимальные размеры.

**ПРИМЕЧАНИЕ**

*В случае не достижения минимальной площади пола, свяжитесь с вашим дилером.*

*Для получения дополнительной информации о зарядке системы хладагентом см. Руководство по установке наружного блока.*

Refrigerant Amount Cantidad de refrigerante Quantité de frigorigène Quantità di refrigerante Quantidade de refrigerante Mængde af kølemiddel Hoeveelheid koelmiddel Mängd kylmedel Ποσότητα ψυκτικού Количество хладилен агент Množství chladiva Jahutusvahendi kogus Hűtőközeg mennyisége Aukstumaģenta daudzums Aušinimo medžiagos kiekis Ilość czynnika chłodniczego Cantitate de agent frigorific Кол-во хладагента (kg)	Minimum Area Área mínima Surface minimale Superficie minima Área mínima Mindsteareal Minimale oppervlakte Minsta yta Ελάχιστη επιφάνεια Минимална площ Minimální plocha Minimaalne pindala Minimális alapterület Minimālā platība Mažiausias plotas Minimalna powierzchnia Spaṭiu minim Мин. площадь пола (m <sup>2</sup> ) (h <sub>0</sub> :2300 mm)
1.84	1.96
1.9	2.09
2.0	2.32
2.1	2.55
2.2	2.80
2.3	3.06
2.4	3.34
2.5	3.62
2.6	3.92
2.7	4.22
2.8	4.54
2.9	4.87
3.0	5.21
3.5	7.10
4.0	9.27
4.5	11.73
5.0	14.48
5.5	17.52

Minimum room area for installation Área mínima para la instalación Surface minimale de pièce d'installation Superficie minima per l'installazione Área de divisão mínima para a instalação Mindste rumareal for installationen Minimale oppervlakte van de kamer voor de installatie Minsta rumsyta för installation Ελάχιστος χώρος δωματίου για την εγκατάσταση Минимална площ на помещението, необходима за монтажа Minimální rozloha instalační plochy Minimaalne ruumi pindala paigaldamiseks A telepítéshez szükséges minimális alapterület Minimālā telpas platība uzstādīšanai Mažiausias patalpos plotas montavimui Minimalna powierzchnia wymagana do instalacji Suprafață minimă în încăperea pentru instalare Минимальная площадь помещения для установки (m <sup>2</sup> ) (h <sub>0</sub> :2500 mm)	$A_{min} = (m_c^* / (2.5 * LFL^{\wedge(5/4)} * h_0)^{\wedge 2})$
---	--

Total refrigerant amount in the system  
 Cantidad total de refrigerante en el sistema  
 Quantité totale de frigorigène du système  
 Quantità totale di refrigerante nel sistema  
 Quantidade de refrigerante total no sistema  
 Samlet mængde kølemiddel i systemet  
 Totale hoeveelheid koelmiddel in het systeem)  
 Total mängd kylmedel i systemet  
 Συνολική ποσότητα ψυκτικού στο σύστημα  
 Общее количество хладилен агент в системата  
 Celkové množství chladiva v systému  
 Kogu jahutusvahendikogus süsteemis  
 Hűtőközeg összmennyisége a rendszerben  
 Kopējais aukstumaģenta daudzums sistēmā  
 Visas aušinimo medžiagos kiekis sistemoje  
 Łączna ilość czynnika w instalacji  
 Cantitate totală de agent frigorific din sistem  
 Общее количество хладагента в системе  
 (kg)

**GB**

- $A_{min}$ : Minimum installation area of an Indoor unit for a given refrigerant charge  $m_c$  (kg) and considering the installation height  $h_0$  (m<sup>2</sup>)
- $h_0$ : Installation height of the bottom side of the indoor unit + distance from the indoor unit bottom side to the lowest part for which a refrigerant leak may release to the indoor area
- $m_c$ : total system refrigerant charge that could be released to the indoor area in case of undetected refrigerant leak.
- LFL: Lower Flammability Limit for R32, 0,307 kg/m<sup>3</sup> as established by EN 378-1:2016 and ISO 817

**ES**

- $A_{min}$ : área de la instalación mínima de una unidad interior para una carga de refrigerante  $m_c$  (kg) determinada y considerando la altura de instalación  $h_0$  (m<sup>2</sup>).
- $h_0$ : altura de instalación del lado inferior de la unidad interior + distancia desde el lado inferior de la unidad interior hasta la parte más baja del área interior a la que se puede verter refrigerante en caso de fuga.
- $m_c$ : carga total de refrigerante del sistema que podría verse a la fuga en caso de no detectar una fuga de refrigerante.
- LFL: Límite inferior de inflamabilidad del R32 establecido en 0,307 kg/m<sup>3</sup> según las normas EN 378-1:2016 e ISO 817.

**DE**

- $A_{min}$ : Mindestinstallationsfläche eines Innengeräts für eine gewisse Kältemittelmenge  $m_c$  (kg) und unter Berücksichtigung der Installationshöhe  $h_0$  (m<sup>2</sup>).
- $h_0$ : Installationshöhe der Unterseite des Innengeräts + Abstand von der Innengeräteunterseite zum niedrigsten Teil, von dem ein Kältemittelleck zum Innenbereich auftreten kann.
- $m_c$ : Gesamte Kältemittelmenge, die in den Innenbereich bei einem unerkannten Kältemittelleck austreten könnte.
- LFL (Lower Flammability Limit): Untere Explosionsgrenze für R32, 0,307 kg/m<sup>3</sup>, wie durch EN 378-1:2016 und ISO 817 festgelegt.

**FR**

- $A_{min}$ : Surface d'installation minimale d'une unité intérieure pour une charge de fluide frigorigène donnée  $m_c$  (kg) et en considérant une hauteur d'installation  $h_0$  (m<sup>2</sup>).
- $h_0$ : Hauteur de l'installation du côté inférieur de l'unité intérieure + distance entre le côté inférieur de l'unité intérieure et la partie la plus basse depuis laquelle une fuite du fluide frigorigène pourrait couler sur la surface intérieure.
- $m_c$ : Charge de fluide frigorigène totale du système qui pourrait couler sur la surface intérieure en cas de fuite non détectée.
- LFL : Limite d'explosivité basse pour R32, 0,307 kg/m<sup>3</sup> comme défini par les normes EN 378-1:2016 et ISO 817.

**IT**

- $A_{min}$ : Superficie minima di installazione di un'unità interna per una certa carica di refrigerante  $m_c$  (kg) e considerando l'altezza di installazione  $h_0$  (m<sup>2</sup>).
- $h_0$ : Altezza di installazione del lato inferiore dell'unità interna + distanza dal lato inferiore dell'unità interna alla parte più bassa da cui può verificarsi una perdita di refrigerante verso l'area interna.
- $m_c$ : Carica di refrigerante totale del sistema che potrebbe fuoriuscire nell'area interna se non vengono rilevate perdite di refrigerante.
- LFL: Limite inferiore di infiammabilità per R32, 0,307 kg/m<sup>3</sup> come stabilito dagli standard EN 378-1:2016 e ISO 817.

**PT**

- $A_{min}$ : Área de instalação mínima para uma unidade interior com uma dada carga de refrigerante  $m_c$  (kg) e considerando a altura da instalação  $h_0$  (m<sup>2</sup>).
- $h_0$ : Altura da instalação do lado inferior da unidade interior + distância do lado inferior da unidade interior para a parte mais baixa na qual pode ocorrer uma fuga de refrigerante para a área interior.
- $m_c$ : carga total do refrigerante do sistema que pode ser libertada na área interior em caso de fuga de refrigerante não detetada.
- LFL: Limite de Inflamabilidade Baixa para R32, 0,307 kg/m<sup>3</sup> conforme definido pelas normas EN 378-1:2016 e ISO 817

**DA**

- $A_{min}$ : Minimums-areal for installation af en indendørsenhed med en bestemt fyldningsmængde  $m_c$  (kg) i forhold til installationshøjden  $h_0$  (m<sup>2</sup>)
- $h_0$ : Installationshøjden af indendørsenhedens underside + afstand fra indendørsenhedens underside til den laveste del hvorfra, der kan slippe kølemiddel ud i indendørsområdet.
- $m_c$ : den samlede fyldningsmængde af kølemiddel, der kan slippe ud i indendørsområdet i tilfælde af en uopdaget læk.
- LFL: Nedre brændbarhedsgrænse for R32, 0,307 kg/m<sup>3</sup> i henhold til EN 378-1:2016 og ISO 817.

**NL**

- $A_{min}$ : Minimumvereiste oppervlakte voor de installatie van een binneneunit met een bepaalde hoeveelheid koelmiddel  $m_c$  (kg) gezien de hoogte waarop de installatie wordt uitgevoerd  $h_0$  (m<sup>2</sup>).
- $h_0$ : Hoogte van de installatie van de onderkant van de binneneunit + afstand van de onderkant van de binneneunit tot de onderste kant waar het koelmiddel in het interieur mag lekken.
- $m_c$ : totale hoeveelheid koelmiddel die vanuit het apparaat in het interieur zou kunnen lekken bij een niet-gedetectede koelmiddellekkage.
- LFL: Onderste ontvlambaarheidslimiet voor R32, 0,307 kg/m<sup>3</sup> in overeenstemming met EN 378-1:2016 en ISO 817.

**SV**

- $A_{min}$ : Minsta installationsområdet av en inomhusenhet för en viss köldmediepåfyllning  $m_c$  (kg) med beaktande av installationshöjden  $h_0$  (m<sup>2</sup>).
- $h_0$ : Installationshöjd från inomhusenhetens undersida + avstånd från inomhusenhetens undersida till den lägsta delen varifrån kylmedel kan läcka in i till inomhusområdet.
- $m_c$ : Total köldmediepåfyllning från systemet som kan frigöras till inomhusenhetens område vid oupptäckt kylmedelläckage.
- LFL: Låg brännbarhetsgräns R32, 0,307 kg/m<sup>3</sup> såsom fastställt av EN 378-1:2016 och ISO 817.

**EL**

- $A_{min}$ : Ελάχιστος χώρος εγκατάστασης μίας εσωτερικής μονάδας για μία δεδομένη πλήρωση με ψυκτικό μέσο  $m_c$  (kg) και λαμβάνοντας υπόψη το ύψος εγκατάστασης  $h_0$  (m<sup>2</sup>).
- $h_0$ : Ύψος εγκατάστασης της κάτω πλευράς της εσωτερικής μονάδας + την απόσταση

από την κάτω πλευρά της εσωτερικής μονάδας έως το χαμηλότερο σημείο όπου μπορεί να πραγματοποιηθεί η διαρροή ψυκτικού στον εσωτερικό χώρο.

- $m_c$ : Συνολική πλήρωση με ψυκτικό μέσο του συστήματος που μπορεί ελευθερωθεί στον εσωτερικό χώρο σε περίπτωση που δεν ανιχνευτεί η διαρροή ψυκτικού μέσου.
- LFL: Χαμηλότερο όριο ευφλεκτότητας για R32, 0,307 kg/m<sup>3</sup> σύμφωνα με το EN 378-1:2016 και ISO 817

**BG**

- $A_{min}$ : Минимална площ за монтаж на вътрешно тяло с известно количество хладилен заряд  $m_c$  (kg) и съобразно височината на монтажа  $h_0$  (m<sup>2</sup>)
- $h_0$ : Височината на монтажа на дъното на вътрешното тяло + разстоянието от дъното на вътрешното тяло до най-ниската част, от която може да се получи теч на хладилен агент в помещението.
- $m_c$ : общ хладилен заряд, който евентуално може да изтече в помещението в случай на несаченен теч на хладилен агент.
- LFL: Долен концентрационен предел за разпространение на пламъка за R32, 0,307 kg/m<sup>3</sup> съгласно определеното по EN 378-1:2016 и ISO 817.

**CS**

- $A_{min}$ : Minimální instalační plocha pro vnitřní jednotku s danou náplní chladiva  $m_c$  (kg) při instalační výšce  $h_0$  (m<sup>2</sup>).
- $h_0$ : Instalační výška spodní strany vnitřní jednotky + vzdálenost spodní strany vnitřní jednotky od nejnižší části, pro níž může dojít k úniku chladiva do vnitřního prostoru.
- $m_c$ : celková náplň systémového chladiva, která může uniknout do vnitřního prostoru v případě nezaznamenaného úniku chladiva.
- LFL: Nižší mez hořlavosti (*Lower Flammability Limit*) pro R32, 0,307 kg/m<sup>3</sup>, jak stanovuje EN 378-1:2016 a ISO 817.

**ET**

- $A_{min}$ : Minimaalne paigalduspindala siseseadme jaoks konkreetse jahutusvedeliku kogusega  $m_c$  (kg) ja arvestades paigalduskõrgust  $h_0$  (m<sup>2</sup>).
- $h_0$ : Paigalduskõrgus siseseadme põhjast + kaugus siseseadme põhjast kõiige madalma osani, kuhu võib jahutusvedelikku lekkida siseruumis.
- $m_c$ : Kogu süsteemi jahutusvedelikukogus, mis võiks tuvastamata jahutusvedelikulekke korral vabaneda siseruumi.
- LFL: Alumine süttivuspiir R32, 0,307 kg/m<sup>3</sup> puhul, nagu on sätestatud standardis EN 378-1:2016 ja ISO 817.

**HU**

- $A_{min}$ : A beltéri egység minimum telepítési területe egy adott  $m_c$  (kg) hűtőközeg-töltés és  $h_0$  (m<sup>2</sup>) telepítési magasság mellett.
- $h_0$ : A beltéri egység alsó részének telepítési magassága + a beltéri egység alsó része és a legalacsonyabb rész közötti távolság, ahová a hűtőközeg a beltéri területen szivároghat.
- $m_c$ : A rendszer teljes hűtőközeg-töltése, amely nem észlelt szivárgás esetén a beltéri területbe juthat.
- LFL: Alsó gyulladási határ R32 hűtőközeg, 0,307 kg/m<sup>3</sup> esetében, az EN 378-1:2016 és az ISO 817 szabványban előírtak szerint.

**LV**

- $A_{min}$ : Minimālais iekštelpu ierīces uzstādīšanas laukums konkrētai aukstumaģenta uzpildes masai  $m_c$  (kg) un, ņemot vērā uzstādīšanas augstumu  $h_0$  (m<sup>2</sup>).
- $h_0$ : Iekštelpu ierīces apakšējās daļas uzstādīšanas augstums + attālums no iekštelpu ierīces apakšējās pusēs līdz zemākajai daļai, kurā aukstumaģenta noplūde var izdalīties iekštelpas zonā.
- $m_c$ : Kopējā sistēmas aukstumaģenta uzlāde, kas var atrīvoties iekštelpas zonā, nenoteiktas aukstumaģenta noplūdes gadījumā.
- LFL: Zemāks uzliesmošanas ierobežojums, kas paredzēts R32, 0,307 kg/m<sup>3</sup> kā noteiktis standartā EN 378-1:2016 un ISO 817.

**LT**

- $A_{min}$ : Minimalus vidinio elemento montavimo plotas nustatytam aušinimo medžiagos užpildymui  $m_c$  (kg) ir atsižvelgiant į montavimo aukštį  $h_0$  (m<sup>2</sup>).
- $h_0$ : Vidinio elemento apatinės pusės montavimo aukštis + atstumas nuo vidinio elemento apatinės pusės iki žemiausios dalies, iš kurios aušinimo medžiagos nutekėjimas gali patekti į vidaus zoną.
- $m_c$ : Bendras sistemos aušinimo medžiagos užpildymo kiekis, kuris gali patekti į vidaus zoną nenustatytu aušinimo medžiagos nuotėkiu atveju.
- LFL: R32 žemutinė degumo riba, 0,307 kg/m<sup>3</sup>, kaip nustatyta EN 378-1:016 ir ISO 817.

**PL**

- $A_{min}$ : minimalna powierzchnia podłogi przy montażu jednostki wewnętrznej w stosunku do ilości czynnika chłodniczego  $m_c$  (kg) z uwzględnieniem wysokości montażowej  $h_0$  (m<sup>2</sup>).
- $h_0$ : wysokość montażowa, licząc od dolnej części jednostki wewnętrznej + odległość między nią a najniższym punktem, który może osiągnąć, w przypadku wycieku, uwolniony do pomieszczenia czynnik chłodniczy.
- $m_c$ : całkowita ilość czynnika chłodniczego, która może zostać uwolniona do pomieszczenia, w przypadku niewykrytego wycieku.
- LFL: dolna granica palności czynnika chłodniczego R32 (0,307 kg/m<sup>3</sup>) według norm EN 378-1:2016 i ISO 817.

**RO**

- $A_{min}$ : Suprafața minimă de instalare a unei unități interioare conținând o anumită cantitate de agent frigorific  $m_c$  (kg) și ținând seama de înălțimea de instalare  $h_0$  (m<sup>2</sup>).
- $h_0$ : Înălțimea de instalare a părții de jos a unității interioare + distanța de la partea de jos a unității interioare până la partea cea mai de jos pentru care se poate produce scurgerea de agent frigorific în zona interioară.
- $m_c$ : cantitatea totală de agent frigorific care ar putea fi eliberată în zona interioară în cazul unei scurgeri neobservate de agent frigorific.
- LFL: Limita minimă de inflamabilitate pentru R32, 0,307 kg/m<sup>3</sup> stabilită în EN 378-1:2016 și ISO 817.

**RU**

- $A_{min}$ : Минимальная площадь установки внутреннего блока для заданного заряда хладагента  $m_c$  (kg) с учетом высоты установки  $h_0$  (m<sup>2</sup>).
- $h_0$ : Высота установки нижней стороны внутреннего блока + расстояние от нижней стороны внутреннего блока до самой нижней части, при которой утечка хладагента может попасть во внутреннюю зону.
- $m_c$ : общий объем заправки системы хладагентом, который может быть выпущен во внутреннюю зону в случае не обнаруженной утечки хладагента.
- LFL: нижний предел воспламеняемости для R32, 0,307 кг/м<sup>3</sup> установленный EN 378-1:2016 и ISO 817.





English

 **DANGER**

- Check to ensure that the number of below is within 0.44kg/m<sup>3</sup>. Otherwise it may cause danger situation if the refrigerant in the outdoor unit leaks into the room where this indoor unit is installed.

(Total refrigerant quantity per one outdoor unit)

$$\frac{\text{Total refrigerant quantity per one outdoor unit}}{\text{(Volume of the room where this indoor unit is installed)}} \leq 0.44\text{kg/m}^3$$

For detail, refer to the Installation Manual for outdoor unit.

- Make sure that the refrigerant leakage test should be performed. The refrigerant (Fluorocarbon R410A) for this unit is incombustible, non-toxic and odorless. However if the refrigerant is leaked and is contacted with fire, toxic gas will generate. Also because the fluorocarbon is heavier than air, the floor surface will be filled with it, which could cause suffocation.
- Use the specified non-flammable refrigerant (R410A) to the outdoor unit in the refrigerant cycle. Do not charge material other than R410A into the unit such as hydrocarbon refrigerants (propane or etc.), oxygen, flammable gases (acetylene, etc.) or poisonous gases when installing, maintaining and moving. These flammables are extremely dangerous and may cause an explosion, a fire, and injury.

Español

 **PELIGRO**

- Asegúrese de que la siguiente cifra está en un margen de 0,44kg/m<sup>3</sup>. De lo contrario, podría darse una situación de peligro si se produce una fuga del refrigerante de la unidad exterior en la habitación en la que está instalada la unidad interior.

(Cantidad total de refrigerante por unidad exterior)

$$\frac{\text{Cantidad total de refrigerante por unidad exterior}}{\text{(Volumen de la estancia en la que está instalada la unidad interior)}} \leq 0,44\text{kg/m}^3$$

Para obtener más detalles al respecto, consulte el manual de instalación de la unidad exterior.

- Compruebe que se realiza la prueba de fugas de refrigerante. El refrigerante (R410A fluorocarburo) utilizado en esta unidad es incombustible, no tóxico e inodoro. Sin embargo, si se produce una fuga y entra en contacto con fuego, se generará gas tóxico. El fluorocarburo es más pesado que el aire por lo que se mantendría cerca del suelo y podría provocar asfixia.
- Utilice el refrigerante no inflamable específico (R410A) en el ciclo de refrigerante de la unidad exterior. No utilice productos diferentes del R410A, como hidrocarburos refrigerantes (propano o similares), oxígeno, gases inflamables (acetileno o similares) o gases venenosos cuando instale, mantenga o traslade la unidad. Estos productos inflamables son muy peligrosos y pueden causar explosiones, incendios o lesiones.

Deutsch

 **GEFAHR**

- Stellen Sie sicher, dass die nachstehende Zahl bei 0,44kg/m<sup>3</sup> liegt. Anderenfalls kann eine Gefahrensituation entstehen, wenn Kältemittel aus dem Außengerät in den Raum gelangt, in dem dieses Innengerät eingebaut ist.

(Gesamt-Kältemittelmenge pro Außengerät)

$$\frac{\text{Gesamt-Kältemittelmenge pro Außengerät}}{\text{(Größe des Raums, in dem das Innengerät installiert ist)}} \leq 0,44\text{kg/m}^3$$

Weitere Einzelheiten finden Sie im Installationshandbuch für Außengeräte.

- Stellen Sie sicher, dass der Kältemittellecktest durchgeführt wird. Das Kältemittel (Fluorkohlenstoff R410A) für dieses Gerät ist nicht brennbar, ungiftig und geruchslos. Wenn das Kältemittel allerdings austritt und mit Feuer in Kontakt gerät, wird giftiges Gas erzeugt. Da der Fluorkohlenstoff auch schwerer als Luft ist, wird die Bodenoberfläche damit gefüllt, was zum Ersticken führen kann.
- Verwenden Sie das spezifizierte nicht brennbare Kältemittel (R410A) zum Außengerät und im Kühlkreislauf. Füllen Sie bei der Installation, Wartung und Versetzen des Geräts keine anderen Mittel als R410A (zum Beispiel kein Kohlenwasserstoff-Kältemittel (Propangas etc.), Sauerstoff, brennbare Gase (Acetylen usw.) in das Gerät. Diese brennbaren Mittel sind extrem gefährlich und können zu einer Explosion, einem Brand und zu Verletzungen führen.

Français

 **DANGER**

- Vérifiez que le nombre ci-dessous est dans la limite de 0,44kg/m<sup>3</sup>. Sinon, il existe un risque de situation dangereuse si le frigorigène de l'unité intérieure vient à fuir dans la pièce où l'unité intérieure est installée.

(Quantité de frigorigène totale pour chacun des GE)

$$\frac{\text{Quantité de frigorigène totale pour chacun des GE}}{\text{(Volume de la pièce où l'unité intérieure est installée)}} \leq 0,44\text{kg/m}^3$$

Pour plus de détails, reportez-vous au manuel d'installation du groupe extérieur.

- Assurez-vous que l'essai d'étanchéité de frigorigène est effectué. Le frigorigène (fluorocarbure R410A) pour cette unité est un gaz incombustible, non toxique et inodore. Toutefois, si le frigorigène fuit et entre en contact avec des flammes, un gaz toxique se formera. De plus, le fluorocarbure est plus lourd que l'air, la surface au sol en sera donc chargée, ce qui pourrait provoquer un risque d'asphyxie.
- Utilisez le frigorigène ininflammable spécifié (R410A) pour le groupe extérieur dans le cycle frigorifique. Ne chargez pas de produits autres que du R410A dans l'unité comme des frigorigènes d'hydrocarbure (propane...), de l'oxygène, des gaz inflammables (acétylène...) ou des gaz toxiques pendant l'installation, la maintenance et le déplacement. Ces produits inflammables sont très dangereux et peuvent provoquer un risque d'explosion, d'incendie et des blessures.

**Italiano** **PERICOLO**

- Accertarsi che il valore risultante dall'operazione sotto riportata sia inferiore o uguale a  $0,44 \text{ kg/m}^3$ . In caso contrario potrebbero verificarsi situazioni di pericolo se il refrigerante contenuto nell'unità esterna fuoriuscisse nel locale in cui è installata l'unità interna.  
(Quantità totale di refrigerante per un'unità esterna)

\_\_\_\_\_  $\leq 0,44 \text{ kg/m}^3$

(Dimensioni del locale in cui questa unità interna è installata)

Per informazioni dettagliate, consultare il Manuale di installazione dell'unità esterna.

- Accertarsi che sia stata svolta la prova di tenuta idraulica del refrigerante. Il refrigerante (fluorocarburo R410A) contenuto in questa unità non è infiammabile, non è tossico ed è inodore. Tuttavia, se sono presenti perdite di refrigerante e questo entra in contatto con fuoco, si genererà gas tossico. Anche perché il fluorocarburo è più pesante dell'aria, la superficie del pavimento si riempirebbe di esso, e ciò potrebbe provocare soffocamento.
- Usare il refrigerante non infiammabile specificato (R410A) per l'unità esterna nel ciclo di refrigerazione. Non immettere materiali diversi dall'R410A nell'unità come refrigeranti idrocarburi (propano, ecc.), ossigeno, gas infiammabili (acetilene, ecc.) o nocivi durante l'installazione, la manutenzione e la movimentazione. Questi prodotti infiammabili sono estremamente pericolosi e potrebbero causare esplosioni, incendi e lesioni.

**Português** **PERIGO**

- Certifique-se de que o número abaixo está em  $0,44 \text{ kg/m}^3$ . Caso contrário e se houver uma fuga de refrigerante da unidade exterior na divisão onde a unidade interior está instalada, o mesmo poderá representar um perigo.

(Quantidade total de refrigerante por cada unidade exterior)

\_\_\_\_\_  $\leq 0,44 \text{ kg/m}^3$

(Volume da divisão onde está instalada a unidade interior)

Para mais detalhes, consulte o Manual de instalação da unidade exterior.

- Certifique-se de que realiza o teste de fuga de refrigerante. O refrigerante (fluorcarboneto R410A) para esta unidade é incombustível, atóxico e inodoro. Contudo, se houver uma fuga de refrigerante e se este entrar em contacto com fogo, produz-se um gás tóxico. Como o fluorcarboneto é mais pesado do que o ar, este poderá provocar asfixia se for derramado no chão.
- Utilize o refrigerante especificado (R410A) na unidade exterior no ciclo de refrigeração. Na instalação, manutenção e manuseamento, utilize apenas o R410A e não aplique nenhum outro tipo de material na unidade como, por exemplo, refrigerantes de hidrocarboneto (propano, etc.), oxigénio, gases inflamáveis, (acetileno, etc.) ou gases venenosos. Estes gases inflamáveis são extremamente perigosos e podem causar uma explosão, fogo ou ferimentos.

**Dansk** **FARE**

- Kontrollér, at antallet herunder er inden for  $0,44 \text{ kg/m}^3$ . Ellers kan det skabe en faresituation, hvis kølemidlet i udendørsenheden lækker ind i rummet, hvor indendørsenheden er installeret.

(Samlet kølemiddelmængde for én udendørsenhed)

\_\_\_\_\_  $\leq 0,44 \text{ kg/m}^3$

(Volumen for rummet hvor enheden installeres.)

For yderligere oplysninger, se udendørsenhedens installationsvejledning.

- Sørg for, at der udføres en test for kølemiddellækage. Kølemidlet (fluorcarbon R410A) til denne enhed er ikke-brændbart, men ugiftigt og lugtfrit. Hvis kølemidlet imidlertid lækker og kommer i kontakt med ild, kan der dannes giftige gasser. Og fordi fluorcarbon er tungere end luft, vil gulvets overflade blive fyldt med væsken, hvilket kan forårsage kvælning.
- Brug det anbefalede ikke-brændbare kølemiddel (R410A) til udendørsenheden på kølekredsløbet. Påfyld ikke andre væsker end R410A på enheden, som kølemiddel med kulbrinte (propan osv.), ilt, brændbare gasser (acetylen osv.) eller giftige gasser, under installation, vedligeholdelse og flytning. Disse brændbare substanser er ekstremt farlige og kan forårsage eksplosion, brand og skade.

**Nederlands** **GEVAAR**

- Controleer op het onderstaande cijfer onder de  $0,44 \text{ kg/m}^3$  valt. Zo niet, dan kan dit tot gevaarlijke situaties leiden waarbij het koudemiddel vanuit de buitenunit in het vertrek waar de binnenunit is geïnstalleerd, lekt.

(totale hoeveelheid koudemiddel per buitenunit)

\_\_\_\_\_  $\leq 0,44 \text{ kg/m}^3$

(volume van de kamer waarin de binnenunit is geïnstalleerd)

Raadpleeg de installatiehandleiding van de buitenunit voor meer details.

- Zorg ervoor dat een lekkagetest van het koelmiddelcircuit wordt uitgevoerd. Het koelmiddel (fluormethaan R410A) voor deze unit is niet-ontvlambaar, niet-giftig en geurloos. Als het koelmiddel echter lekt en in aanraking komt met vuur, dan komen giftige gassen vrij. Omdat fluormethaan zwaarder is dan lucht, vult het de kamer van onderen op, wat verstikking kan veroorzaken.
- Gebruik het niet-ontvlambare koelmiddel (R410A) voor het koelmiddelcyclus. Zorg ervoor dat tijdens het installeren, onderhouden en vervoeren van de unit geen andere materiaal dan R410A in de unit raakt zoals koolwaterstof (propan etc.), zuurstof, ontvlambare gassen (acetyleen etc.) of giftige gassen. Deze ontvlambare stoffen zijn uiterst gevaarlijk en kunnen explosie, brand en verwondingen veroorzaken.

**Svenska** **FARA**

- Kontrollera och se till att numret på följande ligger inom 0,44 kg/m<sup>3</sup>. Om utomhusenhetens kylmedel läcker in i rummet där inomhusenheten är installerad kan en farlig situation uppstå.  
(Total mängd kylmedel per utomhusenhet)

$$\leq 0,44 \text{ kg/m}^3$$

(Volym på rummet där den här inomhusenheten är installerad)

Se utomhusenhetens installationshandbok för detaljerade anvisningar.

- Försäkra att ett läckagetest av kylmedium utförs. Enhetens kylmedel (flourkolgas R410A) är obrännbart, ogiftigt och luktfritt. Om kylmedium läcker ut och kommer i kontakt med eld så kan emellertid giftig gas att bildas. Eftersom flourkolgas är tyngre än luft, fyller den golvytan, vilket även kan leda till kvävning.
- Använd det specificerade icke brännbara kylmedlet (R410A) för utomhusenhetens kylmediecykel. Fyll inte enheten med något annat medel än R410A som exempelvis kylmedel som innehåller kolväte (propan etc.), syra, brandfarliga gaser (acetylen, etc.) eller giftiga gaser under installation, underhåll eller flyttning. Dessa gastyper är mycket farliga och kan orsaka explosion, brand eller skada.

**Ελληνικά** **ΚΙΝΔΥΝΟΣ**

- Βεβαιωθείτε ότι ο χαμηλότερος αριθμός είναι εντός 0,44kg/m<sup>3</sup>. Διαφορετικά ενδέχεται να είναι επικίνδυνο αν γίνει διαρροή του ψυκτικού της εσωτερικής μονάδας μέσα στο χώρο που έχει εγκατασταθεί η εσωτερική μονάδα.  
(Συνολική ποσότητα ψυκτικού ανά μια εξωτερική μονάδα)

$$\leq 0,44 \text{ kg/m}^3$$

(Μέγεθος δωματίου όπου έχει εγκατασταθεί αυτή η εσωτερική μονάδα)

Για λεπτομέρειες, ανατρέξτε στο εγχειρίδιο εγκατάστασης για την εξωτερική μονάδα.

- Βεβαιωθείτε ότι έχετε εκτελέσει τον έλεγχο για διαρροή ψυκτικού. Το ψυκτικό (Φθοράνθρακας R410A) για αυτή τη μονάδα είναι μη εύφλεκτο, μη τοξικό και άοσμο. Ωστόσο, αν γίνει διαρροή ψυκτικού και έρθει σε επαφή με φωτιά, θα παραχθεί τοξικό αέριο. Επίσης, επειδή ο φθοράνθρακας είναι πιο βαρύτερος από τον αέρα, η επιφάνεια στο δάπεδο θα γεμίσει από αυτό, το οποίο μπορεί να προκαλέσει ασφυξία.

Χρησιμοποιήστε το ειδικό μη εύφλεκτο ψυκτικό (R410A) στην εξωτερική μονάδα στον κύκλο ψύξης. Μην ρίχνετε κάποιο άλλο υλικό εκτός από το R410A στη μονάδα όπως ψυκτικά υδρογονάνθρακα (προπάνιο ή κ.λπ.), οξυγόνο, εύφλεκτα υλικά (ασετυλίνη, κ.λπ.) ή δηλητηριώδη αέρια κατά την εγκατάσταση, τη συντήρηση και την μετακίνηση. Αυτά τα εύφλεκτα υλικά είναι πολύ επικίνδυνα και μπορεί να προκαλέσουν έκρηξη, φωτιά και τραυματισμό.

**Български** **ОПАСНОСТ**

- Проверете, за да се уверите, че числото отдолу е в рамките на 0,44 kg/m<sup>3</sup>. Иначе може да се предизвика опасна ситуация, ако хладилният агент във външното тяло протече в помещението, където е монтирано това вътрешно тяло.

(Общо количество хладилен агент на едно външно тяло)

$$\leq 0,44 \text{ kg/m}^3$$

(Обем на помещението, където е монтирано това вътрешно тяло)

За повече подробности виж Ръководството за инсталиране на външното тяло.

- Необходимо е да е сигурно, че е извършено изпитването за теч на хладилния агент. Хладилният агент (флуоровъглерод R410A) за това изделие е негорим, неотровен и без миризма. При това обаче, ако хладилният агент протече и влезе в контакт с огън, ще се получи отровен газ. Освен това, тъй като флуоровъглеродът е по-тежък от въздуха, повърхността на пода ще се запълни с него, а оттам може да настъпи задушаване.
- За хладилния цикъл на външното тяло се използва специален хладилен агент (R410A). При монтаж, поддържане и преместване в изделието да не се зарежда материал, различен от R410A, например въглеродородни хладилни агенти (пропан и др.), кислород, възпламеними газове (ацетилен и др.) или отровни газове. Тези леснозапалими вещества са изключително опасни, тъй като могат да предизвикат взрив, пожар и раняване.

**Čeština** **NEBEZPEČÍ**

- Zkontrolujte, zda je níže uvedené číslo v rozmezí 0,44 kg/m<sup>3</sup>. V opačném případě může dojít k nebezpečné situaci, pokud chladivo ve venkovní jednotce pronikne do místnosti, kde je tato vnitřní jednotka instalována.

(Celkové množství chladiva na jednu venkovní jednotku)

$$\leq 0,44 \text{ kg/m}^3$$

(Objem místnosti, kde je tato jednotka nainstalována)

Podrobné informace naleznete v návodu k instalaci pro venkovní jednotku.

- Ujistěte se, zda není třeba provést test úniku chladiva. Chladivo (Fluorocarbon R410A) pro tento přístroj je nehořlavé, netoxické a bez zápachu. Nicméně pokud je chladivo vytečená a je v kontaktu s požárem, vytváří toxický plyn. Také proto, že fluorovaný uhlovodík je těžší než vzduch, povrch podlahy se naplní, což může způsobit udušení.

## R410A

- Použijte specifikované nehořlavé chladivo (R410A) na venkovní jednotku v chladicím cyklu. Nevkládejte do zařízení jiný materiál než R410A, jako jsou například chladicí kapaliny (propan nebo jiné), kyslík, hořlavé plyny (acetylen atd.) Nebo jedovaté plyny při instalaci, údržbě a pohybu. Tyto hořlaviny jsou extrémně nebezpečné a mohou způsobit výbuch, požár a zranění.

### Eesti

#### OHT

- Kontrollige, et all olev arv on kuni 0,44kg/m<sup>3</sup>. Vastasel korral võib tekkida ohuolukord, kui väliseadmele lekib jahutusvedelikku ruumi, kuhu see siseseade on paigaldatud.

(Kogu jahutusvedelikukogus ühe väliseadme kohta)

$\leq 0,44\text{kg/m}^3$   
(Siseseadme paigaldusruumi maht)

Vaadake täpsemalt järele väliseadme paigaldusjuhendist.

- Veenduge, et jahutusvedelikulekke test on kindlasti tehtud. Selle seadme jahutusvedelik (fluorosüsivesinik R410A) on tulekindel, mittetoksiline ja lõhnatu. Kui jahutusvedelikku lekib ja see puutub kokku tulega, võib siiski tekkida toksiline gaas. Ka seetõttu, et fluorsüsivesinik on raskem kui õhk, laotub see üle kogu pörandapinna ja võib põhjustada lämbumist.
- Kasutage jahutussüsteemis väliseadmete spetsiaalset mittesüttivat jahutusvedelikku (R410A). Ärge laske paigaldamise, hooldustööde ja liigutamise ajal seadmesse muud materjali kui R410A, näiteks süsivesinime baasil jahutusvedelikke (propani vms), hapnikku, tuleohtlikke gaase (atsetüleen vms) või mürgiseid gaase. Need tuleohtlikud ained on äärmiselt ohtlikud ja võivad põhjustada plahvatust, tulekahju ja vigastusi.

### Magyar

#### VESZÉLY

- Győződjön meg róla, hogy az alábbiak 0,44kg/m<sup>3</sup> értéken belül vannak. Ellenkező esetben veszélyt jelenthet, ha a kültéri egységben található hűtőközeg beszivárog abba a helyiségbe, ahová a beltéri egység be van szerelve.

(Összes hűtőközeg mennyiség kültéri egységenként)

$\leq 0,44\text{kg/m}^3$   
(A beltéri egységet tartalmazó helyiség térfogata)

A részleteket lásd a kültéri egység Telepítési útmutatójában.

- Biztosítsa a hűtőközeg szivárgásvizsgálatának végrehajtását. A készülékben található hűtőközeg (R410A fluorkarbon) nem gyúlékony, nem mérgező és szagtalan. Ha azonban a kiszivárgott hűtőközeg tűzzel érintkezik, mérgező gáz keletkezik. Mivel a fluorkarbon a levegőnél nehezebb, a padló szintjén felgyülemlik, és fulladást okozhat.
- A hűtőközeg ciklusban a kültéri egységnek megfelelő nem gyúlékony hűtőközeget (R410A) kell használni. A telepítés, karbantartás vagy mozgatás során a készülékbe az R410A-tól eltérő anyagokat, például szénhidrogén alapú hűtőközegeket (propán vagy hasonló), oxigént, gyúlékony gázokat (acetilén stb.) vagy mérgező gázokat ne töltsön. Ezek a tűzveszélyes anyagok rendkívül veszélyesek, és robbanást, tüzet és sérülést okozhatnak.

### Latviešu

#### BĪSTAMI

- Pārbaudiet, lai pārlicinātos, vai zemāk esošais skaitlis ir 0,44kg/m<sup>3</sup>. Pretējā gadījumā var rasties bīstama situācija, ja dzesējošais līdzeklis no āra ierīces nokļūst telpā, kurā uzstādīta šī iekārtu ierīce.

(Kopējais dzesētājvielas daudzums uz vienu āra ierīci)

$\leq 0,44\text{kg/m}^3$   
(Telpas tilpums, kurā uzstādīta šī iekārtu ierīce)

Detalizētu informāciju skatiet Āra ierīces uzstādīšanas rokasgrāmatā.

- Nodrošiniet, lai tiktu veikts dzesēšanas šķidrums noplūdes tests. Šīs ierīces dzesētājviela (Fluorocarbon R410A) neuzliesmo, nav toksiska un neož. Tomēr, ja dzesētājviela noplūst un nonāk saskarē ar uguni, izdalās toksiskas gāzes. Arī tāpēc, ka fluorogleklis ir smagāks par gaisu un nosēžas uz grīdas virsmas, kas var izraisīt nosmakšanu.
- Izmantojiet norādīto neuzliesmojošu dzesētājvielu (R410A) āra ierīcei dzesēšanas cikla laikā. Uzstādīšanas, apkopes un pārvietošanas darbu laikā neuzpildiet ierīci ar tādiem materiāliem kā ogļūdeņradi saturošas dzesētājvielas (propāns vai līdzīgas), skābekli, uzliesmojošas (acetilēns, utt.) vai indīgas gāzes. Šie uzliesmojošie materiāli ir ļoti bīstami un var izraisīt sprādzienu, ugunsgrēku un traumas.

### Lietuvių

#### PAVOJUS

- Įsitinkite, kad žemiau pateiktas skaičius yra 0,44kg/m<sup>3</sup> ribose. Priešingu atveju tai gali sukelti pavojų, jei išoriniame elemente esanti aušinimo medžiaga pateks į kambarį, kuriame šis vidinis elementas montuojamas.

(Bendras aušinimo medžiagos kiekis vienam išoriniam elementui)

$\leq 0,44\text{kg/m}^3$   
(Kambario, kuriame šis vidinis elementas sumontuotas tūris)

Išsamesnės informacijos ieškokite išorinio elemento montavimo vadove.

## R410A

- Įsitikinkite, kad atliktas aušinimo medžiagos nuotėkio patikrinimas. Šio elemento aušinimo medžiaga (Anglies fluoridas R410A) yra nedegi, netoksiška ir bekvapė. Tačiau aušinimo medžiagai pratekėjus ir susijungus su ugnimi, susidaro nuodingos dujos. Be to, anglies fluoridas yra sunkesnis už orą, todėl jam užpildžius grindų paviršių, gali sukelti uždusimą.
- Išorinio elemento aušinimo ciklui naudokite nurodytą nedegią aušinimo medžiagą (R410A). Nepripilkite kitos nei R410A medžiagos, pvz., angliavandenilių aušinimo medžiagų (propano ar pan.), deguonies, degių dujų (acetileno ar pan.) ar nuodingų dujų montuodami, prižiūradami ir perkeldami. Šie degieji skysčiai yra labai pavojingi ir gali sukelti sprogimą, gaisrą ir sužeidimus.

### Polski

## NIEBEZPIECZEŃSTWO

- Należy upewnić się, że obliczona według poniższego wzoru wartość nie przekracza 0,44 kg/m<sup>3</sup>. W przeciwnym wypadku, ewentualny wyciek czynnika chłodniczego z instalacji do pomieszczenia, w którym zamontowano jednostkę wewnętrzną może stanowić poważne zagrożenie.

(Łączna ilość czynnika na jednostkę zewnętrzną)

$$\frac{\text{(Kubatura pomieszczenia, w którym zainstalowano jednostkę wewnętrzną)}}{\leq 0,44 \text{ kg/m}^3}$$

Szczegółowe informacje na ten temat znajdują się w Instrukcji montażu jednostki zewnętrznej.

- Należy bezwzględnie przeprowadzić próbe szczelności obiegu chłodniczego. Przeznaczony do niniejszej jednostki wewnętrznej fluorowęglowodorowy czynnik chłodniczy R410A jest niepalny, nietoksyczny i bezwonny. W przypadku jednak jego wycieku w pobliżu źródeł ognia, następuje wydzielanie toksycznych gazów. Ponadto jest on cięższy od powietrza i, zalegając w dolnych partiach pomieszczenia, stanowi zagrożenie uduszeniem.
- W obiegu chłodniczym jednostki zewnętrznej należy stosować zalecany niepalny czynnik chłodniczy (R410A). Podczas instalacji, serwisowania lub transportu urządzenia, niedopuszczalne jest jego napełnianie innymi chłodziwami niż R410A, takimi jak czynniki chłodnicze węglowodorowe (np. propan) oraz tlen i gazy łatwopalne (acetylen itp.) lub trujące. Wszystkie te produkty są niezwykle niebezpieczne i stanowią zagrożenie wybuchem i pożarem oraz mogą spowodować poważne obrażenia.

### Română

## PERICOL

- Verificați pentru a vă asigura că numărul de mai jos este în limita a 0,44kg/m<sup>3</sup>. În caz contrar poate apărea un pericol dacă agentul frigorific din unitatea exterioară se scurge în încăperea în care este instalată această unitate interioară.

(Cantitatea totală de agent frigorific pe o unitate exterioară)

$$\frac{\text{(Volumul încăperii în care este instalată această unitate interioară)}}{\leq 0,44 \text{ kg/m}^3}$$

Pentru detalii, consultați Manualul de instalare al unității exterioare.

- Asigurați-vă că se efectuează testul de scurgere a agentului frigorific. Agentul frigorific (Fluorocarbon R410A) folosit cu această unitate este necombustibil, netoxic și inodor. Totuși, dacă agentul frigorific se scurge și intră în contactat cu focul, va genera gaz toxic. De asemenea, deoarece fluorocarbonul este mai greu decât aerul, se va acumula la nivelul podelei, putând provoca sufocare.
- Utilizați agentul frigorific neinflamabil specificat (R410A) pentru unitatea exterioară în ciclul de agent frigorific. Nu introduceți în unitate alte substanțe decât R410A, ca de exemplu agenți frigorifici pe bază de hidrocarburi (propan sau similar), oxigen, gaze inflamabile (acetilenă etc.) sau gaze toxice în timpul instalării întreținerii și deplasării. Aceste gaze inflamabile sunt extrem de periculoase și pot provoca o explozie, incendiu și răni.

### Русский

## ОПАСНО

- Убедитесь, что следующая цифра находится в пределах 0,44 кг/м<sup>3</sup>. В противном случае существует опасность при утечке хладагента из наружного блока в комнату, где установлен внутренний блок.

(Общее количество хладагента для наружного блока)

$$\frac{\text{(Объем помещения, где установлен внутренний блок)}}{\leq 0,44 \text{ кг/м}^3}$$

Для дополнительной информации см. руководство по установке наружного блока.

- Убедитесь в проведении испытания на утечку хладагента. Хладагент (фтороуглерод R410A), используемый в этом блоке, является негорючим, нетоксичным, без запаха. Тем не менее, при его утечке и вступлении в контакт с огнем, образуется токсичный газ. Фтороуглерод тяжелее воздуха, поэтому он собирается в нижней части помещения и может вызвать асфиксию.
- Используйте специальный негорючий хладагент (R410A) в цикле хладагента наружного блока. Не используйте другие продукты, отличные от R410A, хладагенты такие как пропан или аналогичные, кислород, легковоспламеняющиеся (ацетилен или аналогичные) или ядовитые газы при установке, обслуживании или перемещении устройства. Эти легковоспламеняющиеся продукты очень опасны и могут вызывать взрывы, пожары или травмы.



EN	English	Original Version
ES	Español	Versión traducida
DE	Deutsch	Übersetzte Version
FR	Français	Version traduite
IT	Italiano	Versione tradotta
PT	Português	Versão traduzida
DA	Dansk	Oversat version
NL	Nederlands	Vertaalde versie
SV	Svenska	Översatt version
EL	Ελληνικά	Μεταφρασμένη έκδοση

#### EN

The English version is the original one; other languages are translated from English. Should any discrepancy occur between the English and the translated versions, the English version shall prevail.

#### ES

La versión en inglés es la original, y las versiones en otros idiomas son traducciones de la inglesa. En caso de discrepancias entre la versión inglesa y las versiones traducidas, prevalecerá la versión inglesa.

#### DE

Die englische Fassung ist das Original, und die Fassungen in anderen Sprachen werden aus dem Englischen übersetzt. Sollten die englische und die übersetzten Fassungen voneinander abweichen, so hat die englische Fassung Vorrang.

#### FR

La version anglaise est la version originale; les autres langues sont traduites de l'anglais. En cas de divergence entre les versions anglaise et traduite, la version anglaise prévaudra.

#### IT

La versione inglese è l'originale e le versioni in altre lingue sono traduzioni dall'inglese. In caso di divergenze tra la versione inglese e quelle tradotte, fa fede la versione inglese.

#### PT

A versão inglesa é a original; as versões em outras línguas são traduzidas do inglês. Em caso de divergência entre a versão em língua inglesa e as versões traduzidas, faz fé a versão em língua inglesa.

#### DA

Den engelske udgave er originalen, og udgaverne på andre sprog er oversat fra engelsk. Hvis der forekommer uoverensstemmelse mellem den engelske og den oversatte sprogudgave, vil den engelske udgave være gældende.

#### NL

De Engelse versie is de originele; andere talen zijn vertaald uit het Engels. In geval van verschillen tussen de Engelse versie en de vertaalde versies, heeft de Engelse versie voorrang.

#### SV

Den engelska versionen är originalet, och versionerna på andra språk är från engelska översättningar. I händelse av bristande överensstämmelse mellan den engelska och den översatta versionerna, skall den engelska versionen vara giltig.

#### EL

Η αγγλική έκδοση είναι το πρωτότυπο και οι εκδόσεις σε άλλες γλώσσες μεταφράζονται από τα αγγλικά. Σε περίπτωση που διαπιστωθούν διαφορές μεταξύ της αγγλικής και της μεταφρασμένης έκδοσης, η αγγλική έκδοση είναι επικρατέστερη.

EN	English	Original Version
BG	Български	Преведена версия
CS	Čeština	Přeložená verze
ET	Eesti	Tõlgitud versioon
HU	Magyar	Lefordított változat
LV	Latviešu	Tulkotā versija
LT	Lietuvių	Versta versija
PL	Polski	Tłumaczenie wersji oryginalnej
RO	Română	Versiune tradusă
RU	Русский	Переведенная версия

#### BG

Версията на английски език е оригиналната; версията на останалите езици са в превод от английски език. При различие между английската версия и преводна версия на друг език за меридавна се счита английската версия.

#### CS

Originální verze tohoto dokumentu je v angličtině; ostatní jazykové varianty jsou z angličtiny přeložené. Pokud mezi anglickou a jakoukoli jinou jazykovou verzí dojde k rozporu, bude převažovat anglická verze.

#### ET

Originaalversioon on ingliskeelne; teised keeled on tõlge inglise keelest. Vastuolude korral ingliskeelse ja tõlkeversioonide vahel kehtib eesõiguslikult ingliskeelne versioon.

#### HU

Az eredeti változat az angol; az egyéb nyelvű változatok angolról lettek fordítva. Amennyiben az angol és a fordított verziók között bármilyen eltérés mutatkozik, az angol nyelvű változat a mérvadó.

#### LV

Angļu valodas versija ir oriģināla; citas valodas tiek tulkotas no angļu valodas. Ja starp angļu valodu un tulkoto versiju rodas jebkādas neatbilstības, noteicošais ir angļu valodas variants.

#### LT

Versija anglų kalba yra originali; versijos kitomis kalbomis yra išverstos iš anglų kalbos. Jei yra neatitikimų tarp versijos anglų kalba ir verstinių versijų, pirmenybė teikiama versijai anglų kalba.

#### PL

Wersja angielska jest wersją oryginalną - wszystkie pozostałe stanowią jej tłumaczenie na odpowiednie języki. W przypadku stwierdzenia jakichkolwiek rozbieżności między oryginałem a jego tłumaczeniem, rozstrzygająca jest wersja w języku angielskim.

#### RO

Versiunea originală este cea în limba engleză; versiunile în alte limbi sunt traduse din limba engleză. Dacă există vreo discrepanță între versiunile în limba engleză și versiunea tradusă, prevalează versiunea în limba engleză.

#### RU

Английская версия является оригинальной; другие языки переведены с английского. В случае любого расхождения между английской и переведенной версиями, английская версия имеет преимущественную силу.

**INDEX**

- 1 GENERAL INFORMATION
- 2 SAFETY
- 3 IMPORTANT NOTICE
- 4 INDOOR UNIT TYPE LIST
- 5 AVAILABLE REMOTE CONTROL SWITCH
- 6 EFFICIENT USE
- 7 MAIN PARTS
- 8 AIR FLOW DIRECTION
- 9 EMERGENCY OPERATION
- 10 OTHER INDICATIONS
- 11 NAME OF PARTS
- 12 BEFORE INSTALLATION
- 13 INDOOR UNIT INSTALLATION
- 14 REFRIGERANT PIPING WORK
- 15 DRAIN PIPING
- 16 ELECTRICAL WIRING
- 17 TEST RUN
- 18 MAINTENANCE
- 19 TROUBLESHOOTING

**ÍNDICE**

- 1 INFORMACIÓN GENERAL
- 2 SEGURIDAD
- 3 AVISO IMPORTANTE
- 4 DESCRIPCIÓN DEL SISTEMA
- 5 MANDOS A DISTANCIA DISPONIBLES
- 6 USO EFICIENTE
- 7 COMPONENTES PRINCIPALES
- 8 DIRECCIÓN DEL FLUJO DE AIRE
- 9 FUNCIONAMIENTO DE EMERGENCIA
- 10 OTRAS INDICACIONES
- 11 NOMBRE DE LOS COMPONENTES
- 12 ANTES DE LA INSTALACIÓN
- 13 INSTALACIÓN DE LA UNIDAD INTERIOR
- 14 INSTALACIÓN DE LA TUBERÍA DE REFRIGERANTE
- 15 TUBERÍA DE DESAGÜE
- 16 CABLEADO ELÉCTRICO
- 17 PRUEBA DE FUNCIONAMIENTO
- 18 MANTENIMIENTO
- 19 RESOLUCIÓN DE PROBLEMAS

**INHALTSVERZEICHNIS**

- 1 ALLGEMEINE INFORMATIONEN
- 2 SICHERHEIT
- 3 WICHTIGER HINWEIS
- 4 SYSTEMBESCHREIBUNG
- 5 VERFÜGBARE FERNBEDIENUNG
- 6 EFFIZIENTE VERWENDUNG
- 7 HAUPTTEILE
- 8 LUFTSTROMRICHTUNG
- 9 NOTBETRIEB
- 10 ANDERE ANZEIGEN
- 11 TEILEBEZEICHNUNG
- 12 VOR DER INSTALLATION
- 13 INSTALLATION DES INNENGERÄTS
- 14 VERLEGUNG DER KÄLTEMITTELLEITUNGEN
- 15 ABFLUSSLEITUNGEN
- 16 KABELANSCHLUSS
- 17 TESTLAUF
- 18 WARTUNG
- 19 FEHLERBEHEBUNG

**INDEX**

- 1 INFORMATIONS GÉNÉRALES
- 2 SÉCURITÉ
- 3 REMARQUES IMPORTANTES
- 4 DESCRIPTION DU SYSTÈME
- 5 TÉLÉCOMMANDE DISPONIBLE
- 6 UTILISATION EFFICACE
- 7 COMPOSANTS PRINCIPAUX
- 8 DIRECTION DU DÉBIT D'AIR
- 9 FONCTIONNEMENT DE SECOURS
- 10 AUTRES INDICATIONS
- 11 NOMENCLATURE DES PIÈCES
- 12 AVANT L'INSTALLATION
- 13 INSTALLATION DE L'UNITÉ INTÉRIEURE
- 14 TRAVAUX DE TUYAUTERIE FRIGORIF
- 15 TUYAUTERIE D'ÉVACUATION
- 16 CÂBLAGE ÉLECTRIQUE
- 17 TEST DE FONCTIONNEMENT
- 18 MAINTENANCE
- 19 DÉPANNAGE

**INDICE**

- 1 INFORMAZIONI GENERALI
- 2 SICUREZZA
- 3 NOTA IMPORTANTE
- 4 DESCRIZIONE DEL SISTEMA
- 5 DISPOSITIVO DI CONTROLLO REMOTO DISPONIBILE
- 6 UTILIZZO EFFICIENTE
- 7 COMPONENTI PRINCIPALI
- 8 DIREZIONE DEL FLUSSO DELL'ARIA
- 9 FUNZIONAMENTO DI EMERGENZA
- 10 ALTRE INDICAZIONI
- 11 NOME DEI COMPONENTI
- 12 PRIMA DELL'INSTALLAZIONE
- 13 INSTALLAZIONE DELL'UNITÀ INTERNA
- 14 POSA DELLA LINEA DEL REFRIGERANTE
- 15 LINEA DI DRENAGGIO
- 16 COLLEGAMENTI ELETTRICI
- 17 PROVA DI FUNZIONAMENTO
- 18 MANUTENZIONE
- 19 RISOLUZIONE DEI PROBLEMI

**ÍNDICE**

- 1 INFORMAÇÃO GERAL
- 2 SEGURANÇA
- 3 NOTA IMPORTANTE
- 4 DESCRIÇÃO DO SISTEMA
- 5 CONTROLLO REMOTO DISPONÍVEL
- 6 UTILIZAÇÃO EFICIENTE
- 7 PEÇAS PRINCIPAIS
- 8 DIREÇÃO DO FLUXO DE AR
- 9 FUNCIONAMENTO DE EMERGÊNCIA
- 10 OUTRAS INDICAÇÕES
- 11 NOME DAS PEÇAS
- 12 ANTES DA INSTALAÇÃO
- 13 INSTALAÇÃO DA UNIDADE INTERIOR
- 14 INSTALAÇÃO DA TUBAGEM DE REFRIGERANTE
- 15 TUBAGEM DE DESCARGA
- 16 LIGAÇÕES ELÉTRICAS
- 17 TESTE DE FUNCIONAMENTO
- 18 MANUTENÇÃO
- 19 RESOLUÇÃO DE PROBLEMAS

**INDHOLDSFORTEGNELSE**

- 1 GENEREL INFORMATION
- 2 SIKKERHED
- 3 VIGTIG ANMÆRKNING
- 4 SYSTEMBESKRIVELSE
- 5 TILGÆNGELIG FJERNBETJENING
- 6 EFFEKTIV BRUG
- 7 VIGTIGE DELE
- 8 LUFTSTRØMSRETNING
- 9 NØDDRIFT
- 10 ANDRE INDIKATIONER
- 11 NAVN PÅ DELE
- 12 INDEN MONTERING
- 13 INSTALLATION AF INDENDØRSENHED
- 14 KØLERØRSARBEJDE
- 15 AFLØBSRØR
- 16 ELEKTRISK LEDNINGSFØRING
- 17 TESTKØRSEL
- 18 VEDLIGEHOLDELSE
- 19 FEJLFINDING

**INHOUDSOPGAVE**

- 1 ALGEMENE INFORMATIE
- 2 VEILIGHEID
- 3 BELANGRIJKE MEDEDELING
- 4 SYSTEEMBESCHRIJVING
- 5 BESCHIKBARE AFSTANDSBEDIENINGEN
- 6 EFFICIËNT GEBRUIK
- 7 BELANGRIJKSTE ONDERDELEN
- 8 LUCHTSTROOMRICHTING
- 9 NOODBEDIENING
- 10 OVERIGE INDICATORS
- 11 NAMEN VAN ONDERDELEN
- 12 VÓÓR INSTALLATIE
- 13 DE BINNENUNIT INSTALLEREN
- 14 KOELMIDDELLEIDINGEN INSTALLEREN
- 15 AFVOERLEIDING
- 16 ELEKTRISCHE BEDRADING
- 17 PROEFDRAAIEN
- 18 ONDERHOUD
- 19 PROBLEMEN OPLOSSEN



**INNEHÅLLSFÖRTECKNING**

- 1 ALLMÄN INFORMATION
- 2 SÄKERHET
- 3 VIKTIG ANMÄRKNING
- 4 SYSTEMÖVERSIKT
- 5 TILLGÄNGLIG FJÄRRKONTROLL
- 6 EFFEKTIV ANVÄNDNING
- 7 HUVUDDelar
- 8 LUFTFLÖDETS RIKTNING
- 9 NÖDDRIFT
- 10 ÖVRIGA INDIKATIONER
- 11 DELARNAS NAMN
- 12 FÖRE INSTALLATIONEN
- 13 INSTALLATION AV INOMHUSENHET
- 14 KYLRÖRSARBETE
- 15 DRÄNERINGSRÖR
- 16 ELEKTRISK ANSLUTNING
- 17 PROVkörNING
- 18 UNDERHÅLL
- 19 FELSÖKNING

**ΕΥΡΕΤΗΡΙΟ**

- 1 ΓΕΝΙΚΕΣ ΠΛΗΡΟΦΟΡΙΕΣ
- 2 ΑΣΦΑΛΕΙΑ
- 3 ΣΗΜΑΝΤΙΚΗ ΠΑΡΑΤΗΡΗΣΗ
- 4 ΠΕΡΙΓΡΑΦΗ ΣΥΣΤΗΜΑΤΟΣ
- 5 ΔΙΑΘΕΣΙΜΟΣ ΔΙΑΚΟΠΤΗΣ ΤΗΛΕΧΕΙΡΙΣΤΗΡΙΟΥ
- 6 ΑΠΟΤΕΛΕΣΜΑΤΙΚΗ ΧΡΗΣΗ
- 7 ΚΥΡΙΑ ΕΞΑΡΤΗΜΑΤΑ
- 8 ΚΑΤΕΥΘΥΝΣΗ ΡΟΗΣ ΑΕΡΑ
- 9 ΛΕΙΤΟΥΡΓΙΑ ΕΚΤΑΚΤΟΥ ΑΝΑΓΚΗΣ
- 10 ΑΛΛΕΣ ΕΝΔΕΙΞΕΙΣ
- 11 ΟΝΟΜΑΤΑ ΕΞΑΡΤΗΜΑΤΩΝ
- 12 ΠΡΙΝ ΤΗΝ ΕΓΚΑΤΑΣΤΑΣΗ
- 13 ΕΓΚΑΤΑΣΤΑΣΗ ΕΣΩΤΕΡΙΚΗΣ ΜΟΝΑΔΑΣ
- 14 ΕΡΓΑΣΙΕΣ ΣΩΛΗΝΩΣΗΣ ΨΥΚΤΙΚΟΥ
- 15 ΣΩΛΗΝΩΣΗ ΑΠΟΧΕΤΕΥΣΗΣ
- 16 ΗΛΕΚΤΡΙΚΗ ΚΑΛΩΔΙΩΣΗ
- 17 ΕΛΕΓΧΟΣ ΛΕΙΤΟΥΡΓΙΑΣ
- 18 ΣΥΝΤΗΡΗΣΗ
- 19 ΑΝΤΙΜΕΤΩΠΙΣΗ ΠΡΟΒΛΗΜΑΤΩΝ

**ИНДЕКС**

- 1 ОБЩА ИНФОРМАЦИЯ
- 2 БЕЗОПАСНОСТ
- 3 ВАЖНА БЕЛЕЖКА
- 4 ОПИСАНИЕ НА СИСТЕМАТА
- 5 НАЛИЧНО ДИСТАНЦИОННО УПРАВЛЕНИЕ
- 6 ΕΦΕΚΤΙВНА УΠΟΤΡΕΒΑ
- 7 ГЛАВНИ ЧАСТИ
- 8 ПОСОКА НА ВЪЗДУШНИЯ ПОТОК
- 9 ΕΚΣΠΛΟΑΤΑЦИЯ ПРИ ИЗВЪНРЕДЕН РЕЖИМ НА РАБОТА
- 10 ДРУГИ ИНДИКАЦИИ
- 11 НАЗВАНИЯ НА ЧАСТИТЕ
- 12 ПРЕДИ ΜΟΝΤΑЖ
- 13 ΜΟΝΤΑЖ НА ВЪТРЕШНОТО ΤΥΛΟ
- 14 СЪΕДИНЯВАНЕ НА ΤΡЪБИТЕ ЗА ΧΛΑΔΙΛΝΙΑ АГЕНТ
- 15 ДΡΕΝΑЖНИ ΤΡЪБИ
- 16 ΕΛΕΚΤΡΙΧΕΣΚΟ ΟΚΑΒΕΛΥΑΝΕ
- 17 ΙΖΠΙΤΑΤΕΛΕΝ ЦΙΚЪЛ
- 18 ΠΟΔΔΡЪЖКА
- 19 ΟΤΣΤΡΑΝΥΑВАНЕ НА ПОВРЕΔΙ

**OBSAH**

- 1 OBECNÉ INFORMACE
- 2 BEZPEČNOST
- 3 DŮLEŽITÉ UPOZORNĚNÍ
- 4 POPIS SYSTÉMU
- 5 DOSTUPNÉ DÁLKOVÉ OVLÁDÁNÍ
- 6 ΕΦΕΚΤΙVΝÍ VYUŽITÍ
- 7 HLAVNÍ ČÁSTI
- 8 SMĚR TOKU VZDUCHU
- 9 NOUZOVÝ PROVOZ
- 10 DALŠÍ POKYNY
- 11 NÁZVY DÍLŮ
- 12 PŘED INSTALACÍ
- 13 INSTALACE VNITŘNÍ JEDNOTKY
- 14 PRÁCE NA CHLADICÍM POTRUBÍ
- 15 ODTOKOVÉ POTRUBÍ
- 16 ELEKTROINSTALACE
- 17 ZKUŠEBNÍ CHOD
- 18 ÚDRŽBA
- 19 ODSTRAŇOVÁNÍ PROBLÉMŮ

**INDEKS**

- 1 ÜLDTEAVE
- 2 OHUTUS
- 3 TÄHTIS TEADE
- 4 SÜSTEEMI KIRJELDUS
- 5 SAADAVAL OLEV KAUGJUHTIMISPLOKK
- 6 ΕΦΕΚΤΙVNE KASUTAMINE
- 7 PEAMISED OSAD
- 8 ÖHUVOO SUUND
- 9 AVARIIREŽIIM
- 10 MUUD JUHISED
- 11 OSADE NIMED
- 12 ENNE PAIGALDAMIST
- 13 SISESEADME PAIGALDAMINE
- 14 JAHUTUSTORUSTIKU TÕÖD
- 15 VÄLJALASKETORUSTIK
- 16 ELEKTRIHENDUSED
- 17 KATSETAMINE
- 18 HOOLDUS
- 19 VEAOTSING

**TARTALOM**

- 1 ÁLTALÁNOS INFORMÁCIÓK
- 2 BIZTONSÁG
- 3 FONTOS FIGYELMEZTETÉS
- 4 A RENDSZER LEÍRÁSA
- 5 RENDELKEZÉSRE ÁLLÓ TÁVKAPCSOLÓ
- 6 HATÉKONY HASZNÁLATA
- 7 FŐ ALKATRÉSZEK
- 8 A LÉGÁRAM IRÁNYA
- 9 ÜZEMELÉS VÉSZHELYZETBEN
- 10 EGYÉB UTASÍTÁSOK
- 11 RÉSZEK NEVE
- 12 TELEPÍTÉS ELŐTT
- 13 A BELTÉRI EGYSÉG TELEPÍTÉSE
- 14 HŰTŐKÖZEG CSÓVEZETÉKEINEK BEKÖTÉSE
- 15 VÍZELVEZETŐ CSŐVEK
- 16 ELEKTROMOS KÁBELEZÉS
- 17 PRÓBAÜZEM
- 18 KARBANTARTÁS
- 19 HIBAELHÁRÍTÁS

**INDEKSS**

- 1 VISPĀRĪGA INFORMĀCIJA
- 2 DROŠĪBA
- 3 SVARĪGA PIEZĪME
- 4 SISTĒMAS APRAKSTS
- 5 PĪEEJAMĀIS TĀLVADĪBAS PULTS SLĒDZIS
- 6 ΕΦΕΚΤΙVĀ ΙΖΜΑΝΤΟŠANA
- 7 GALVENĀS DAĻAS
- 8 GAISA PLŪSMĀS VIRZIENS
- 9 ĀRKĀRTAS DARBĪBA
- 10 CĪTAS INDIKĀCIJAS
- 11 DETALU NOSAUKUMS
- 12 PIRMŠ UZSTĀDĪŠANAS
- 13 IEKŠTELPU IERĪCES UZSTĀDĪŠANA
- 14 DZESĒTĀJVIELAS CAURULVADU DARBS
- 15 DRENĀŽAS CAURULVADI
- 16 ELEKTROINSTALĀCIJA
- 17 TESTA DARBĪBA
- 18 TEHNISKĀ APKOPE
- 19 TRAUCĒJUMMEKLĒŠANA

**INDEKSAS**

- 1 BENDROJI INFORMACIJA
- 2 SAUGUMAS
- 3 SVARBI PASTABA
- 4 SISTEMOS APRAŠYMAS
- 5 TINKAMAS NUOTOLINIO VALDYMO JUNGIKLIS
- 6 ΕΦΕΚΤYVUS NAUDOJIMAS
- 7 PAGRINDINĖS DALYS
- 8 ORO SRAUTO KRYPTIS
- 9 AVARINIS VEIKIMAS
- 10 KITOS INDIKACIJOS
- 11 DALIŲ PAVADINIMAI
- 12 PRIEŠ MONTAVIMĄ
- 13 VIDINIO ELEMENTŲ MONTAVIMAS
- 14 AUŠINIMO VAMZDŽIO DARBAI
- 15 DRENAŽO VAMZDYNAS
- 16 ELEKTROS LAIDAI
- 17 TESTINIS PALEIDIMAS
- 18 TECHNINĖ PRIEŽIŪRA
- 19 GEDIMŲ LOKALIZAVIMAS

## SPIS TREŚCI

- 1 INFORMACJE OGÓLNE
- 2 BEZPIECZEŃSTWO
- 3 WAŻNE INFORMACJE
- 4 OPIS INSTALACJI KLIMATYZACYJNEJ
- 5 DOSTĘPNE ZDALNE STEROWNIKI
- 6 EFEKTYWNE UŻYTKOWANIE
- 7 GŁÓWNE CZĘŚCI SKŁADOWE
- 8 KIERUNEK STRUMIENIA POWIETRZA
- 9 PRACA W TRYBIE AWARYJNYM
- 10 POZOSTAŁE WSKAZANIA
- 11 CZĘŚCI SKŁADOWE
- 12 CZYNNOŚCI PRZEDMONTAŻOWE
- 13 MONTAŻ JEDNOSTKI WEWNĘTRZNEJ
- 14 MONTAŻ PRZEWODÓW RURÓWYCH CZYNNIKA CHŁODNICZEGO
- 15 PRZEWÓD ODPLYWU SKROPLIN
- 16 PODŁĄCZENIE ELEKTRYCZNE
- 17 ROZRUCH PRÓBNY
- 18 KONSERWACJA
- 19 ROZWIĄZYWANIE PROBLEMÓW

## SUMAR

- 1 INFORMAȚII GENERALE
- 2 SIGURANȚĂ
- 3 OBSERVAȚIE IMPORTANTĂ
- 4 DESCRIEREA SISTEMULUI
- 5 TELECOMANDĂ DISPONIBILĂ
- 6 UTILIZAREA EFICIENTĂ
- 7 COMPONENTE PRINCIPALE
- 8 DIRECȚIA DEBITULUI DE AER
- 9 FUNCȚIONAREA ÎN REGIM DE URGENȚĂ
- 10 ALTE INDICAȚII
- 11 DENUMIREA COMPONENTELOR
- 12 ÎNAINTE DE INSTALARE
- 13 INSTALAREA UNITĂȚII INTERIOARE
- 14 LUCRĂRI LA CODUȚA DE AGENT FRIGORIFIC
- 15 CONDUCTELE DE DRENAJ
- 16 CABLAJUL ELECTRIC
- 17 PROBĂ DE FUNCȚIONARE
- 18 MENTENANȚĂ
- 19 DEPANARE

## ОГЛАВЛЕНИЕ

- 1 ОБЩАЯ ИНФОРМАЦИЯ
- 2 БЕЗОПАСНОСТЬ
- 3 ВАЖНОЕ ЗАМЕЧАНИЕ
- 4 ОПИСАНИЕ СИСТЕМЫ
- 5 ДОСТУПНЫЙ ПУЛЬТ ДИСТАНЦИОННОГО УПРАВЛЕНИЯ
- 6 ЭФФЕКТИВНОЕ ИСПОЛЬЗОВАНИЕ
- 7 ОСНОВНЫЕ ЧАСТИ
- 8 НАПРАВЛЕНИЕ ПОТОКА ВОЗДУХА
- 9 АВАРИЙНЫЙ РЕЖИМ
- 10 ДРУГИЕ ИНДИКАТОРЫ
- 11 НАЗВАНИЕ ДЕТАЛЕЙ
- 12 ПЕРЕД МОНТАЖОМ
- 13 УСТАНОВКА ВНУТРЕННЕГО БЛОКА
- 14 ПОДКЛЮЧЕНИЕ ТРУБЫ ХЛАДАГЕНТА
- 15 ДРЕНАЖНЫЕ ТРУБЫ
- 16 ЭЛЕКТРОПРОВОДКА
- 17 ПРОБНЫЙ ПУСК
- 18 ТЕХНИЧЕСКОЕ ОБСЛУЖИВАНИЕ
- 19 ПОИСК И УСТРАНЕНИЕ НЕИСПРАВНОСТЕЙ

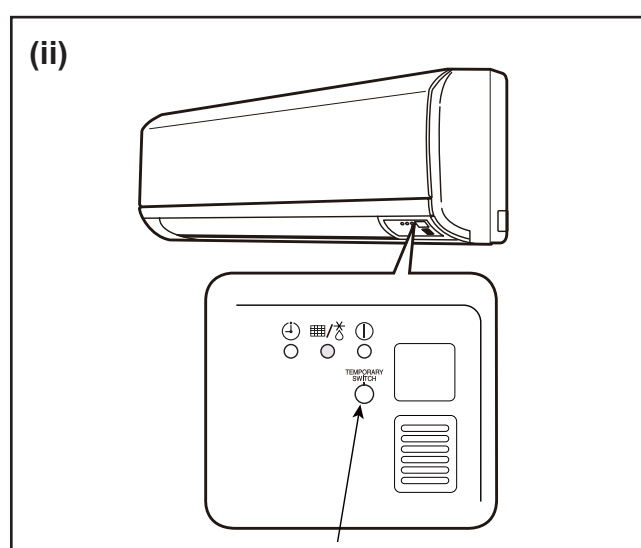
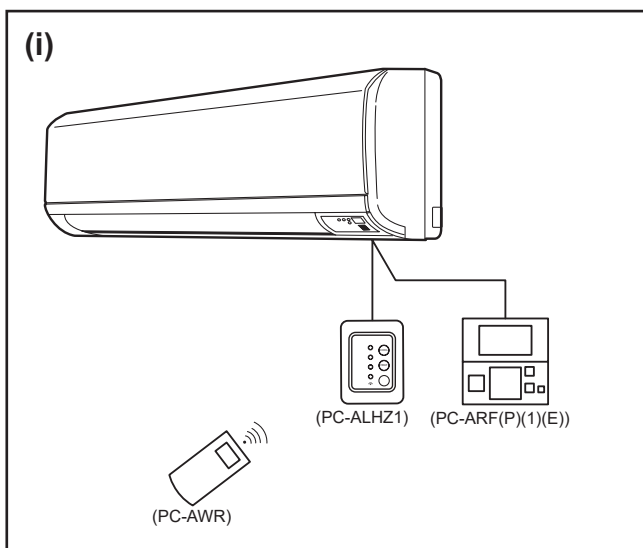

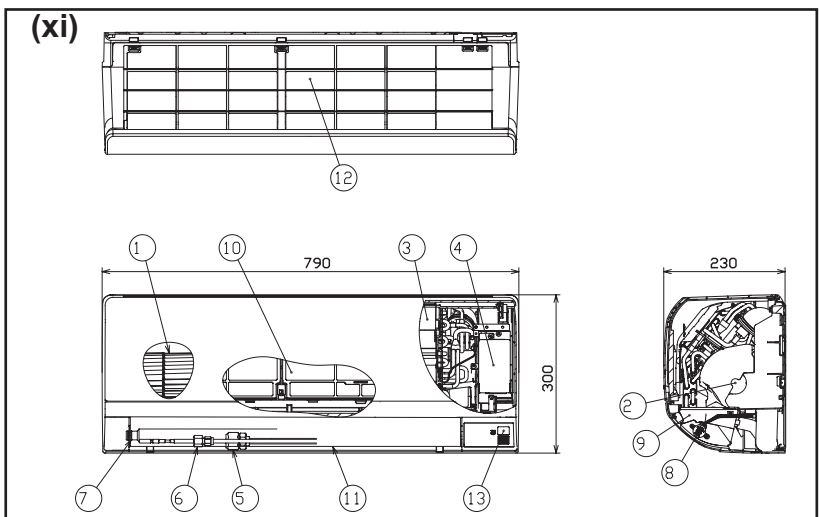
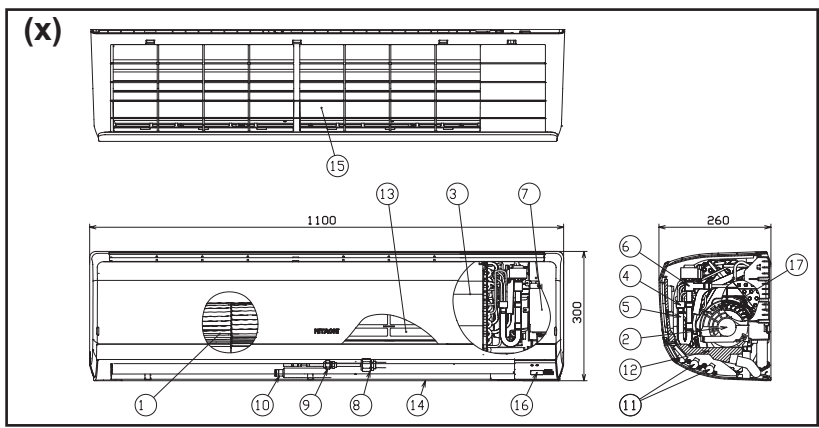
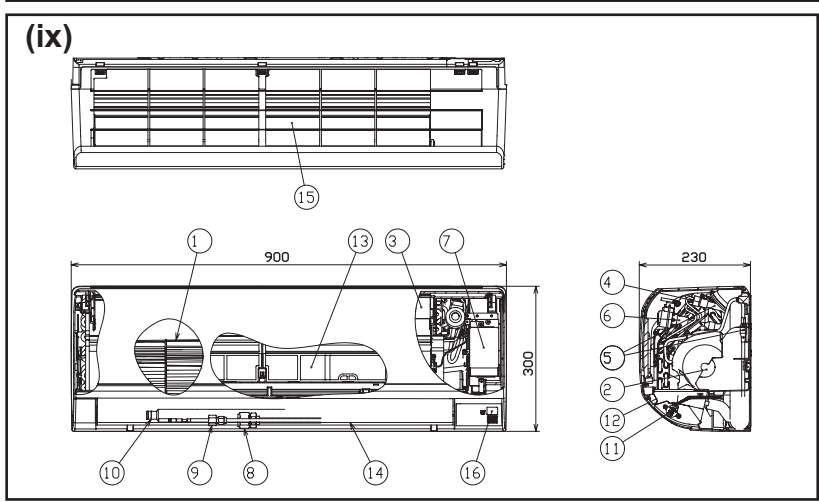
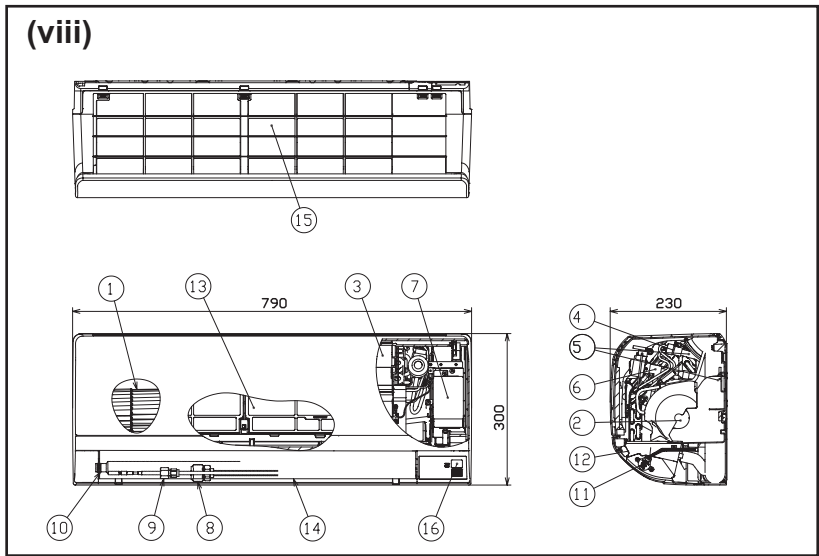
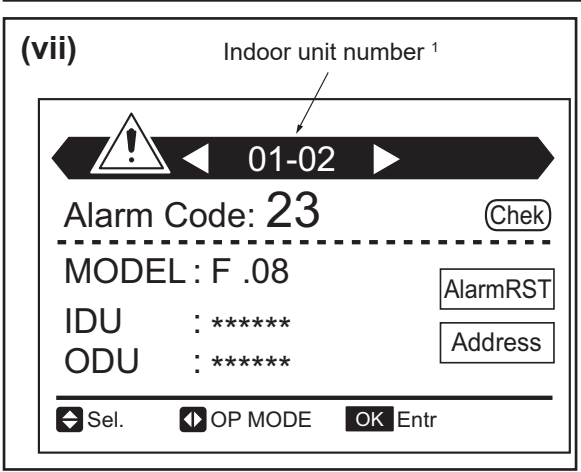
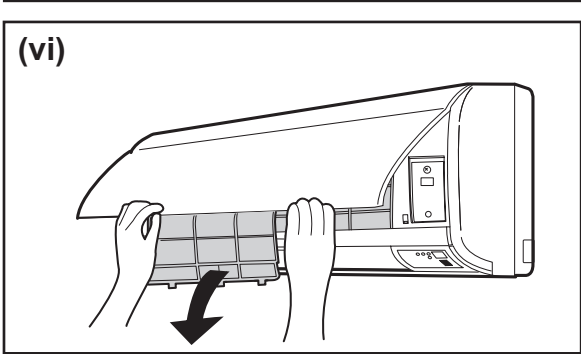
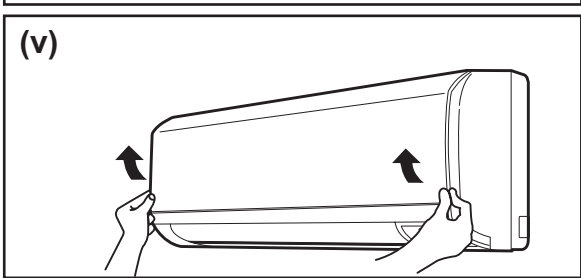
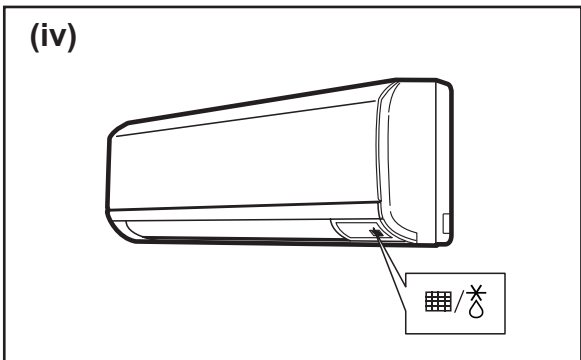
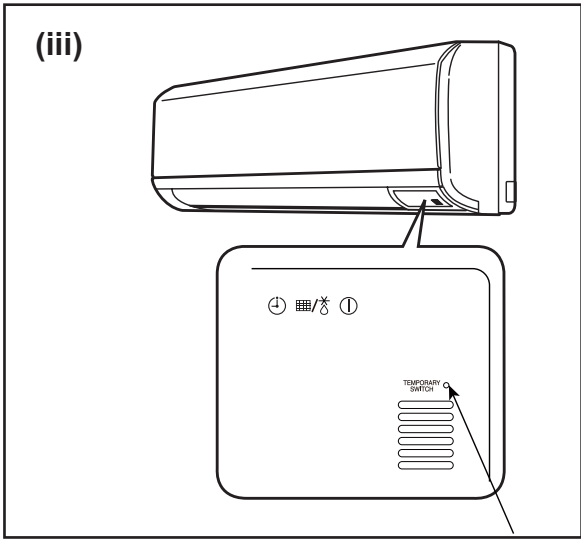

(xii)

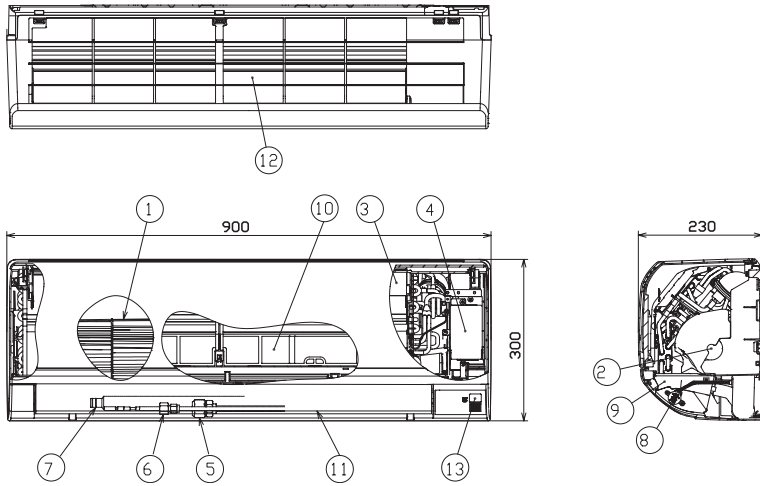

(xiii)

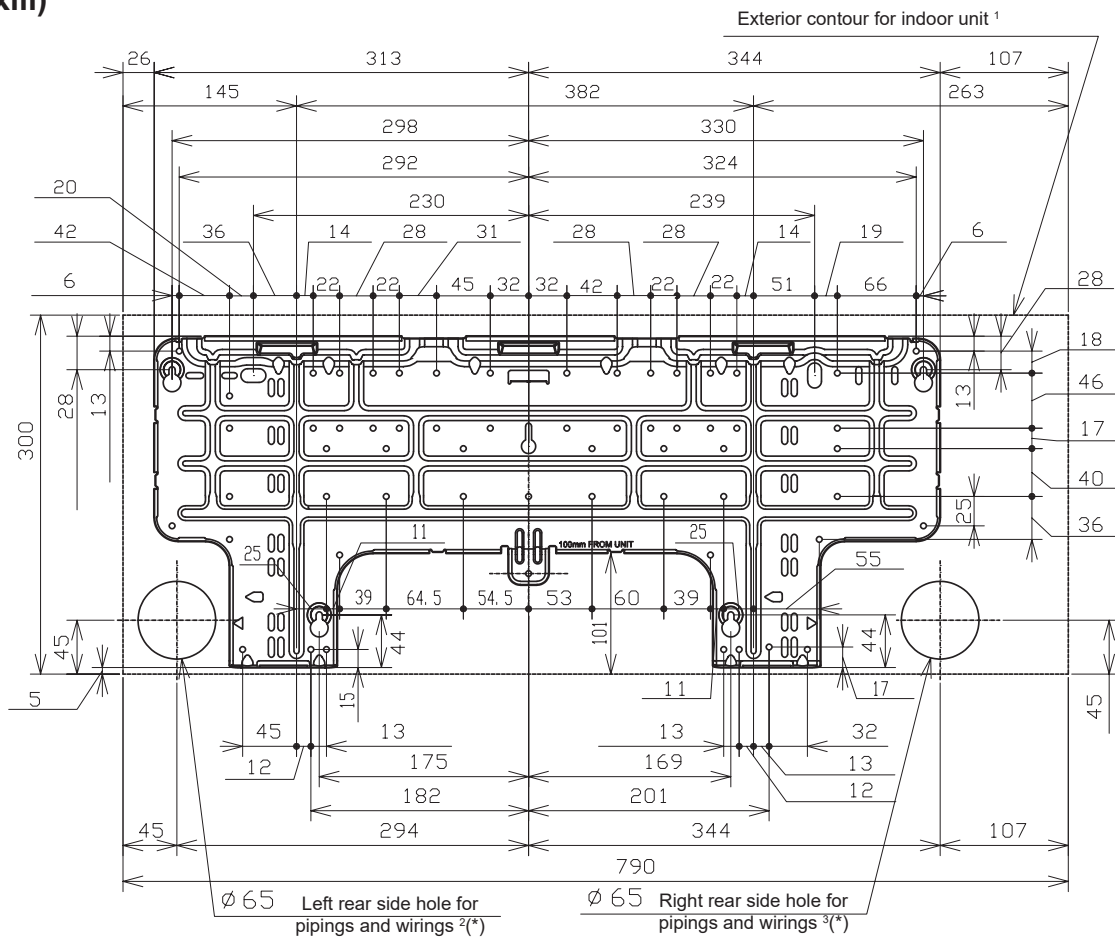





## 1 GENERAL INFORMATION

### 1.1 GENERAL NOTES

No part of this publication may be reproduced, copied, filed or transmitted in any shape or form without the permission of Johnson Controls-Hitachi Air Conditioning Spain, S.A.U.

Within the policy of continuous improvement of its products, Johnson Controls-Hitachi Air Conditioning Spain, S.A.U. reserves the right to make changes at any time without prior notification and without being compelled to introducing them into products previously sold. This document may therefore have been subject to amendments during the life of the product.

Hitachi makes every effort to offer correct, up-to-date documentation. Despite this, printing errors cannot be controlled by Hitachi and are not its responsibility.

As a result, some of the images or data used to illustrate this document may not refer to specific models. No claims will be accepted based on the data, illustrations and descriptions included in this manual.

No type of modification must be made to the equipment without prior, written authorisation from the manufacturer.

### 1.2 PRODUCT GUIDE

#### 1.2.1 Prior check



#### NOTE

Check, depending on the name of the model, the type of air conditioning system fitted, the abbreviated code and reference in this instruction manual. This Installation and Operating Manual only refers to RPK-(0.4-4.0)FSR(H)M units.

Check, in accordance with the Installation and Operating Manuals included with the outdoor and indoor units, that all the information necessary for the correct installation of the system is included. If this is not the case, please contact your distributor.

#### 1.2.2 Classification of indoor unit models

Unit type (indoor unit): RPK							
Position-separating hyphen (fixed)							
Capacity (HP): (0.4-4.0)							
FS: SYSTEM FREE							
R: R32/R410A refrigerant							
(H): Without expansion valve							
M: Made in Malaysia							
XXX	-	XX	FS	R	(H)	M	

## 2 SAFETY

### 2.1 SYMBOLS USED

During normal air conditioning system design work or unit installation, greater attention must be paid in certain situations requiring particular care in order to avoid injuries and damage to the unit, the installation or the building or property.

Situations that jeopardise the safety of those in the surrounding area or that put the unit itself at risk will be clearly indicated in this manual.

To indicate these situations, a series of special symbols will be used to clearly identify these situations.

Pay close attention to these symbols and to the messages following them, as your safety and that of others depends on it.



#### DANGER

- **The text following this symbol contains information and instructions relating directly to your safety, in addition to hazards or unsafe practices which could result in severe personal injuries or death.**
- **Not taking these instructions into account could lead to serious, very serious or even fatal injuries to you and others in the proximities of the unit.**

In the texts following the danger symbol you can also find information on safe procedures during unit installation.



#### CAUTION

- *The text following this symbol contains information and instructions relating directly to your safety, in addition to hazards or unsafe practices which could result in minor personal injury or product or property damage.*
- *Not taking these instructions into account could lead to minor injuries to you and others in the proximities of the unit.*
- *Not taking these instructions into account could lead to unit damage.*

In the texts following the caution symbol you can also find information on safe procedures during unit installation.



#### NOTE

- *The text following this symbol contains information or instructions that may be of use or that require a more thorough explanation.*
- *Instructions regarding inspections to be made on unit parts or systems may also be included.*

## 2.2 ADDITIONAL INFORMATION ABOUT SAFETY

### DANGER

- *Hitachi is not able to foresee all the circumstances which may result in a potential danger.*
- *Do not pour water in the indoor or outdoor unit. These products are fitted with electric components. If water comes into contact with electric components, this will cause a serious electric shock.*
- *Do not handle or adjust the safety devices inside the indoor and outdoor units. The handling or adjustment of these devices may result in serious accident.*
- *Do not open the service cover or access panel of the indoor and outdoor units without disconnecting the main supply.*
- *In the event of fire, switch off the mains, put out the fire immediately and contact your service supplier.*
- *Check that the earth cable is correctly connected.*
- *Connect the unit to a circuit breaker of the specified capacity.*

### CAUTION

- *Refrigerant leaks may hinder respiration as the gas displaces the air in the room.*
- *If abnormality (burnt odor, etc.) occurs, stop the operation and turn OFF the main power source immediately. If not, it may cause breakage of the product, an electric shock or a fire. Contact your distributor or contractor*

- *Fit the indoor unit, the outdoor unit, the remote control and the cable at a minimum of 3 metres away from sources of strong radiation from electromagnetic waves, such as medical equipment.*
- *Do not use sprays, such as insecticides, varnishes or enamels or any other inflammable gas within a metre of the system.*
- *If the circuit breaker or supply fuse of the unit comes on frequently, stop the system and contact the service supplier.*
- *Do not carry out installation, maintenance or inspection work yourself. This work must be carried out by qualified professional installer with suitable tools and resources for the work.*
- *Do not place any foreign material (branches, sticks, etc.) in the air inlet or outlet of the unit. These units are fitted with high speed fans and contact with any object is dangerous.*
- *This appliance must be used only by adult and capable people, having received the technical information or instructions to handle this appliance properly and safely.*
- *Children should be supervised to ensure that they do not play with the appliance.*

### NOTE

- *The air in the room should be renewed and the room ventilated every 3 or 4 hours.*
- *The system fitter and specialist shall provide anti-leak safety in accordance with local regulations.*

## 3 IMPORTANT NOTICE

This air conditioner has been designed for standard air conditioning for human beings. For use in other applications, please contact your Hitachi dealer or service contractor.

The air conditioning system should only be installed by professional installer, with the necessary resources, tools and equipment, who are familiar with the safety procedures required to successfully carry out the installation.

**PLEASE READ AND FAMILIARISE YOURSELF WITH THE MANUAL BEFORE STARTING WORK ON THE INSTALLATION OF THE AIR CONDITIONING SYSTEM.** Failure to observe the instructions for installation, use and operation described in this Manual may result in operating failure including potentially serious faults, or even the destruction of the air conditioning system.

It is assumed that the air conditioning system will be installed and maintained by responsible personnel trained for the purpose. If this is not the case, the customer should include all the safety, caution and operating signs in the native language of the personnel responsible.

Do not install the unit in the following places, as this may lead to a fire, deformities, rusting or faults:

- Places where oil is present (including oil for machinery).
- Places with a high concentration of sulphurous gas, such as spas.
- Places where flammable gases may be generated or circulate.
- Places with a saline, acidic or alkaline atmosphere.

Do not install the unit in places where silicon gas is present. Any silicon gas deposited on the surface of the heat exchanger will repel water. As a result, the condensate water will splash out of the collection tray and into the electrical box. Water leaks or electrical faults may eventually be caused.

Do not install the unit in a place where the current of expelled air directly affects animals or plants as they could be adversely affected.

This heat pump air conditioner has been designed for the following temperatures. Operate the heat pump air conditioner within this range:

Temperature		(°C)	
		Maximum	Minimum
Cooling operation	Indoor	32 DB	21 DB
	Outdoor	48 DB*	-10 DB*
Heating operation	Indoor	27 DB	15 DB
	Outdoor	15 WB*	-20 WB*

DB: Dry Bulb, WB: Wet Bulb

\*The temperature may change depending on the outdoor unit.



## 4 INDOOR UNIT TYPE LIST

Indoor unit type	Nominal capacity (HP)								
	0.4	0.6	0.8	1.0	1.5	2.0	2.5	3.0	4.0
Wall Mounted	△	○	○	○	○	○	○	○	○
Wall Mounted (without expansion valve)	△	○	○	○	○	-	-	-	-

○ : Available  
△ : Available (Only for Europe Area)

### ◆ LIMITATIONS

0.4HP must be in simultaneous operation with another indoor unit (of 0.4HP or higher capacity). This restrictions does not apply for 0.6HP or higher capacity indoor units.

Refer to outdoor unit Technical Documentation for detailed information about installation consideration and restrictions.

## 5 AVAILABLE REMOTE CONTROL SWITCH

wireless remote control switch	PC-AWR
wired remote control switch	PC-ARF(P)(1)(E)
both wired and wireless remote control switches operating at the same time <b>(i)</b>	PC-ARF(P)(1)(E) + ( PC-AWR + PC-ALHZ1 )

Refer to the its corresponding Installation and Operation Manual. Contact your distributor and contractor for detail.

## 6 EFFICIENT USE

### 6.1 EFFICIENT USE OF INDOOR UNIT

- Do not leave a window or a door open.

The operating efficiency will be decreased.

It may cause dew condensation of the indoor unit. (Ventilate a room sufficiently too.)

- Attach a curtain or a blind to a window.

Direct sunlight is prevented and the cooling efficiency will be increased.

- Do not use heating appliances during the cooling operation as possible.

The cooling efficiency will be decreased. It may cause dew condensation and dropping dew.

- Use a circulator if warm air stays around ceiling.

The comfortability will be increased. Contact your distributor for the detail.

- Turn OFF the main power source if the indoor unit is not used for a long time.

If not, the standby electricity charges will have to be paid even if the indoor unit is unused.

### 6.2 EFFICIENT USE OF COOLING AND HEATING

#### COOLING

- Air flow direction: the appropriate air outlet angle is approx  $A^\circ$ . If the cooling is not sufficient, change the air flow direction. Pay attention to dew drop which may occur due to the long cooling operation with low louver angle.

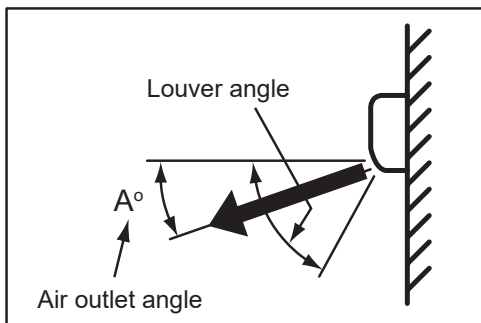

HP	$A^\circ$
0.4-1.5	30
2.0-4.0	32

- Air flow volume: "MED" should be usually used. If the air flow volume is set as "HIGH", the air flow will be spread wider than "MED".
- Temperature: the recommended set temperature is 26 to 28°C. If the cooling is not sufficient, set the lower temperature

#### **i** NOTE

About Multi-Split system

When the number of indoor unit or the operating mode is changed, the air outlet temperature may be changed and the indoor temperature is changed. In this case, set as follows.

- During cooling: lower slightly the temperature setting.
- During heating: raise slightly the temperature setting.

#### HEATING

- Air flow direction: the appropriate air outlet angle is approx  $A^\circ$  as shown in the table. If the heating is not sufficient, change the air flow direction.

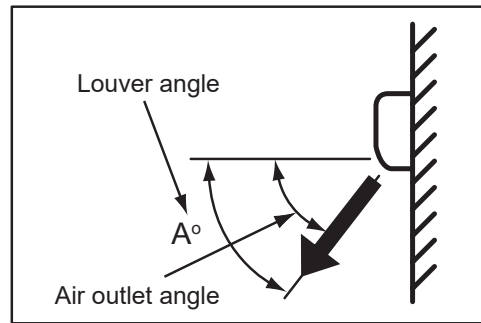

HP	$A^\circ$
0.4-1.5	55
2.0-4.0	50

- Air flow volume: "MED" should be usually used. If the air flow volume is set as "HIGH", the air flow will be spread wider than "MED".
- Temperature: the recommended set temperature is 18 to 22°C. If the heating is not sufficient, set the higher temperature.

#### **i** NOTE

See chapter "8.1 RECOMMENDED AIR FLOW DIRECTION SETTING"

The louver angle is changed automatically during the heating operation.

- When the heating operation starts
- When the defrost operation starts

When the discharge temperature is higher than 30°C, the louver angle is automatically returned to the setting condition.

## 7 MAIN PARTS

### 7.1 RPK-(0.4-4.0)FSR(H)M

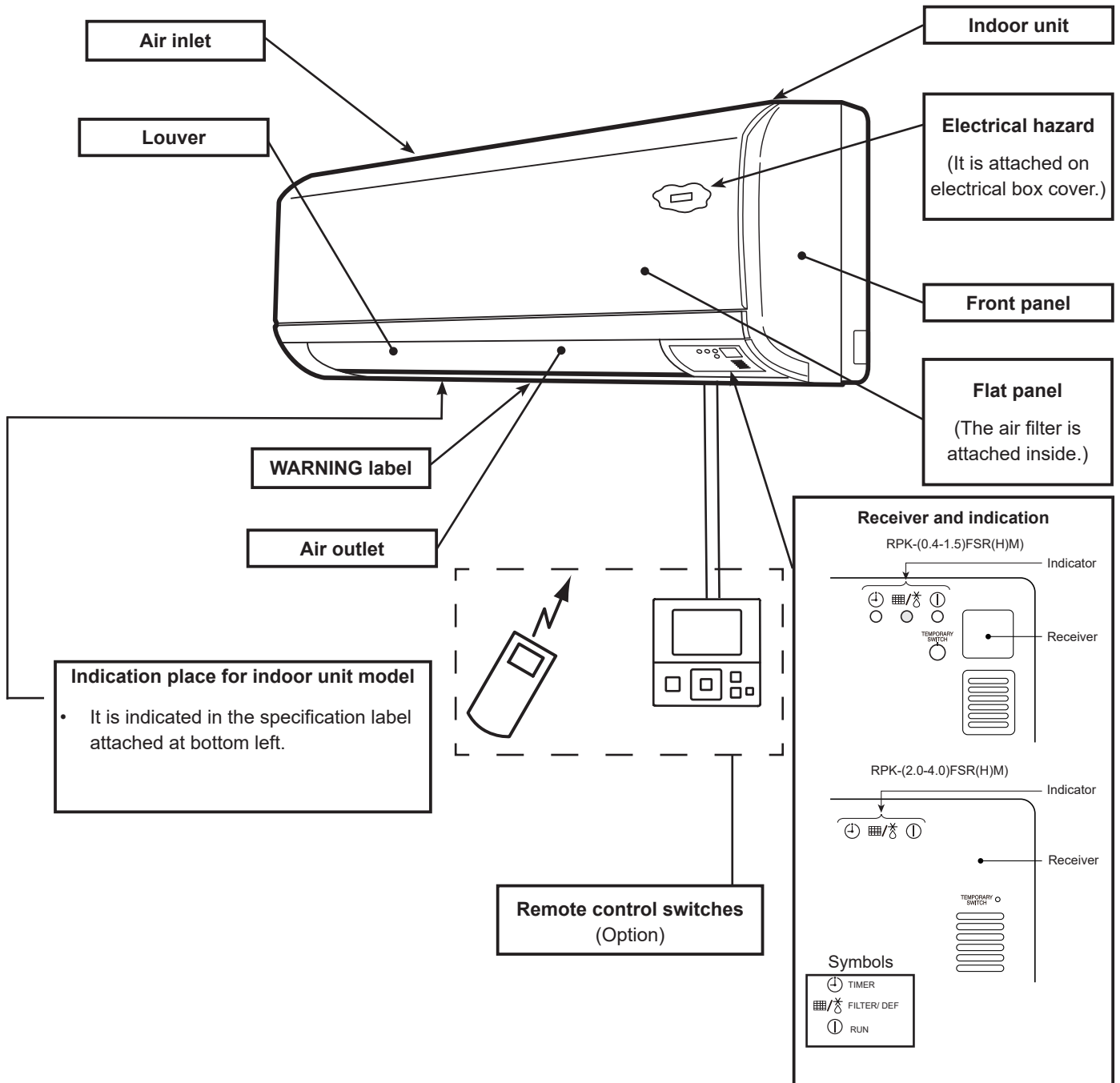

**i** NOTE

Press lightly the switches to control the remote control switch.

- For RPK-FSR(H)M series, either wired or wireless remote control switches are available. However, when the centralized controller is connected, there are restriction in order to operate the multiple indoor units by one wireless remote control switch or utilize the wired and wireless remote control switch together. Contact your distributor or contractor.
- The RUN indicator on indoor unit is turned ON even when the wired remote control switch is utilized. However, the indication for timer settings are only indicated on the wired remote control switch.
- For twin, triple and quad combination, the wired remote control switch shall be utilized. When the wireless remote control switch is utilized, the optional receiver kit is required.
- To utilize the wired and wireless remote control switch together, the optional receiver kit is required.

## 8 AIR FLOW DIRECTION

### 8.1 RECOMMENDED AIR FLOW DIRECTION SETTING

LCD Indication

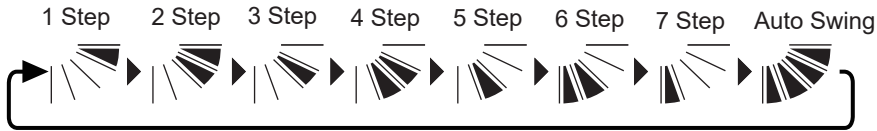

Model	COOL, FAN and DRY	HEAT
RPK-(0.4-1.0)FSR(H)M	Step 3	Step 7
RPK-(1.5-4.0)FSR(H)M	Step 3	

### 8.2 ADJUSTING VERTICAL DEFLECTOR

The vertical deflector can adjust with moving by hand as shown in the figures blow.

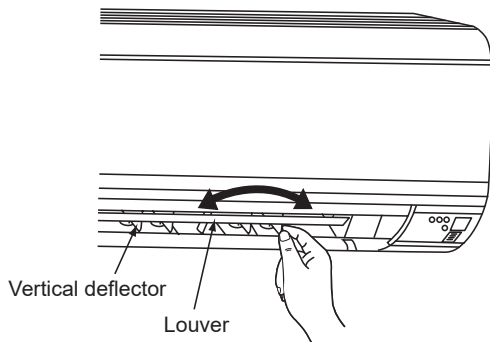

#### CAUTION

Do not move the louver by hand. If moved, the louver mechanism will be damaged and the air flow direction may not be set.

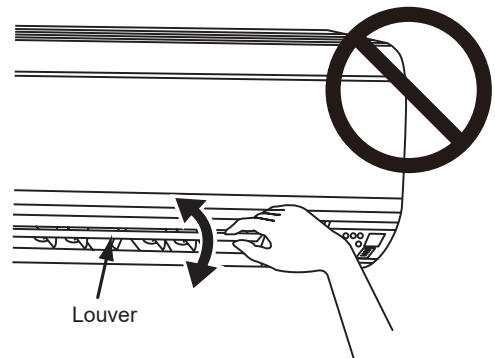

### 8.3 AUTOMATIC SETTING OF LOUVER

The swing louver is stopped and moved by controlling the remote control switch.

When "Stop" switch is pressed from the remote control switch, the swing louver will be closed automatically and the operation is stopped.

## 9 EMERGENCY OPERATION

### 9.1 FUNCTION

The emergency operation switch is used when the batteries for wireless remote control switch are shortage.

#### NOTE

The operation is as follows.

- Automatic cooling/heating operation
- Setting temperature: 25°C
- Fan speed: HIGH
- Louver angle: horizontal

RPK-(0.4-1.5)FSR(H)M: Press the temporary switch (ii)

RPK-(2.0-4.0)FSRM: Press the temporary switch with a non-metallic tool, etc (iii)

The emergency operation is stopped when the temporary switch is pressed again.

#### NOTE

Do not press the switch by metal sticks such as pen, pin, etc. It may cause failure.

## 10 OTHER INDICATIONS



### 10.1 IN NORMAL CONDITION

#### 1 Defrost

- Defrost operation: the “” indicator (yellow) is turned ON during the defrosting. The louver is fixed.

However, the louver indication of LCD continues to activate. (iv)



- Operation stoppage during defrosting

Operation: the RUN indicator “” (orange) is turned OFF when the operation is stopped “” during the defrosting.



However, the operation continues with turning ON the “” indicator (yellow), and the unit is stopped after the defrost operation is finished.

#### 2 Filter sign

The cleaning period for air filter is notified by turning ON the “” indicator (yellow) when the operation time is accumulated 200 hours.

After cleaning, point the transmitter towards the receiver and press “” switch to turn OFF the “” indicator.

### 10.2 ABNORMALITY

- When some troubles occur such as safety device actuation, etc. during the test run or the normal operation, the RUN indicator “” (orange) flashes (0.5 second ON / 0.5 second OFF).
- The alarm codes are indicated by the flashing times of “” (green) and the “” (yellow)

“” (green): the number of flashing is shown at the tens digit of alarm code.

“” (yellow): the number of flashing is shown at the units digit of alarm code. Alphabet is indicated by number of flashing times as follows: A...10 times / B...11 times / C...12 times

#### Example

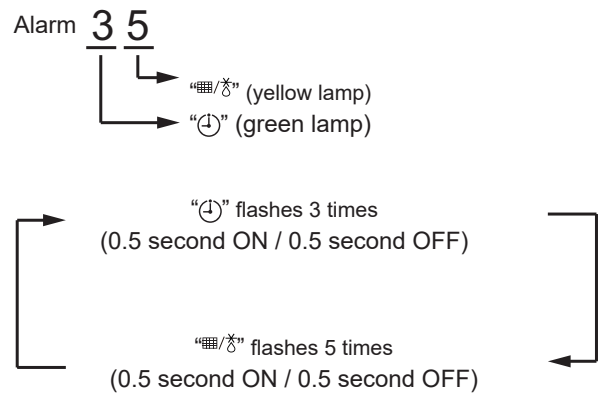

These indications are repeated until the alarm is reset.

### 10.3 POWER FAILURE

- All the indications are OFF.
- Once the unit is stopped by the power failure, the unit will not be started again although the power recovers. Perform the starting procedures again.
- In case of instantaneous power failure within 2 seconds, the unit will be started again automatically.

### 10.4 ELECTRIC NOISE

There could be a case that all the indications are OFF and the unit is stopped. This is occurred by the activation of the micro computer for the unit protection from the electric noise. Perform the starting procedures again.

## 11 NAME OF PARTS

### ◆ RPK-(0.4-1.0)FSRM

(viii)

No.	Part name	Remark
1	Fan	
2	Fan motor	
3	Heat exchanger	
4	Distributor	
5	Strainer	
6	Expansion valve controlled by microcontroller	
7	Electrical control box	
8	Refrigerant gas pipe connection	Ø 12.7 mm (1/2") Flare nut
9	Refrigerant liquid pipe connection	Ø 6.35 mm (1/4") Flare nut
10	Drain pipe connection	VP16
11	Auto louver motor	
12	Drain pan	
13	Air filter	
14	Air outlet	
15	Air inlet	
16	IR Receiver part	

### ◆ RPK-1.5FSRM

(ix)

No.	Part name	Remark
1	Fan	
2	Fan motor	
3	Heat exchanger	
4	Distributor	
5	Strainer	
6	Expansion valve controlled by microcontroller	
7	Electrical control box	
8	Refrigerant gas pipe connection	Ø 12.7 mm (1/2") Flare nut
9	Refrigerant liquid pipe connection	Ø 6.35 mm (1/4") Flare nut
10	Drain pipe connection	VP16
11	Auto louver motor	
12	Drain pan	
13	Air filter	
14	Air outlet	
15	Air inlet	
16	IR Receiver part	

### ◆ RPK-(2.0-4.0)FSRM

(x)

No.	Part name	Remark
1	Fan	
2	Fan motor	
3	Heat exchanger	
4	Distributor	
5	Strainer	
6	Expansion valve controlled by microcontroller	
7	Electrical control box	
8	Refrigerant gas pipe connection	Flare nut
9	Refrigerant liquid pipe connection	Flare nut
10	Drain pipe connection	VP16
11	Auto louver motor	
12	Drain pan	
13	Air filter	
14	Air outlet	
15	Air inlet	
16	IR Receiver part	
17	Condensate guide	

Model	Gas piping	Liquid piping
RPK-2.0FSRM	Ø 12.7mm (1/2")	Ø 6.35mm (1/4")
RPK-(2.5-4.0)FSRM	Ø 15.88mm (5/8)	Ø 9.52mm (3/8")

### ◆ RPK-(0.4-1.0)FSRHM

(xi)

No.	Part name	Remark
1	Fan	
2	Fan motor	
3	Heat exchanger	
4	Electrical control box	
5	Refrigerant gas pipe connection	Ø 12.7 mm (1/2") Flare nut
6	Refrigerant liquid pipe connection	Ø 6.35 mm (1/4") Flare nut
7	Drain pipe connection	VP16
8	Auto louver motor	
9	Drain pan	
10	Air filter	
11	Air outlet	
12	Air inlet	
13	IR Receiver part	

### ◆ RPK-1.5FSRHM

(xii)

No.	Part name	Remark
1	Fan	
2	Fan motor	
3	Heat exchanger	
4	Electrical control box	
5	Refrigerant gas pipe connection	Ø 12.7 mm (1/2") Flare nut
6	Refrigerant liquid pipe connection	Ø 6.35 mm (1/4") Flare nut
7	Drain pipe connection	VP16
8	Auto louver motor	
9	Drain pan	
10	Air filter	
11	Air outlet	
12	Air inlet	
13	IR Receiver part	

## 12 BEFORE INSTALLATION

### 12.1 COMBINATION OF OUTDOOR UNIT AND INDOOR UNIT

The combination capacity of indoor unit against the outdoor unit is selected by the outdoor unit capacity. Refer to the installation manual of outdoor unit and select the indoor unit and the

outdoor unit to be satisfied the combination unit number and the combination unit capacity.

### 12.2 TRANSPORTATION AND HANDLING

#### CAUTION

- Do not put any material on the product.
- Do not step on the product.

#### 12.2.1 Transportation

- Transport the product as close to the installation location as practical before unpacking.
- Do not put any material on the indoor unit.
- Pay attention to handle the indoor unit. If an excessive force is applied to the indoor unit, it may cause a breakage.

#### 12.2.2 Handling of indoor unit

#### DANGER

Do not put any foreign material into the indoor unit and check to ensure that no foreign material exists in the indoor unit before the installation and the test run. Otherwise, a fire or failure, etc. may occur.

#### CAUTION

- The indoor unit covers are resin made. Do not apply an excessive force to the resin covers or make it fall.
- Do not move the louver by hand. If moved, the louver mechanism will be damaged.

#### NOTE

To avoid damage to the resin covers, before lifting or moving the indoor unit, put a cloth on the resin covers.

## 13 INDOOR UNIT INSTALLATION

#### DANGER

- Do not install the indoor unit in a flammable environment to avoid fire or an explosion.
- Do not put any foreign material into the indoor unit and check to ensure that none exists in the indoor unit before the installation and the test run. Otherwise, a fire or failure, etc. may occur.

- Check to ensure that the wall is strong enough. If not strong enough, the indoor unit may fall down on you.
- Do not install the indoor unit outdoors. If installed outdoors, an electric hazard or electric leakage will occur.

#### NOTE

The expansion valve kit EV-1.5N1 (option) is required for the "indoor unit wall type without expansion valve" installation.

### 13.1 FACTORY-SUPPLIED ACCESSORIES

Check to ensure that the following accessories are packed with the indoor unit.

#### NOTE

If any of these accessories are not packed with the unit, please contact your contractor.

- For twin, triple and quad combination for simultaneous operation, the wired remote control switch shall be used. When the wireless remote control switch is used, the optional receiver kit (PC-ALHZ1) is required.

The remote control switch, the branch pipes and the transition wires are optional accessories which are not included with the indoor unit.

Pay attention to the followings when the wireless remote control switch (PC-AWR) is used.

- For twin, triple and quad combination for individual operation with the wireless remote control switch, the optional receiver kit is required. (This operation is NOT available with the wireless remote control switch if the built-in receiver is only used.)

Accessory	Quantity		Purpose
	0.4-1.5	2.0-4.0	
Suspension bracket	1	1	For mounting indoor unit
Screw (Ø4 x 25L)	6	8	For fixing suspension bracket
Screw (Ø4 x 40L)	2	4	
Thermal Insulation pipe	1	1	For insulating refrigerant piping
Installation and operation manual	1	1	-

## 13.2 INITIAL CHECK

- Install the indoor unit with a proper clearance around it for operation, maintenance working space and safety.

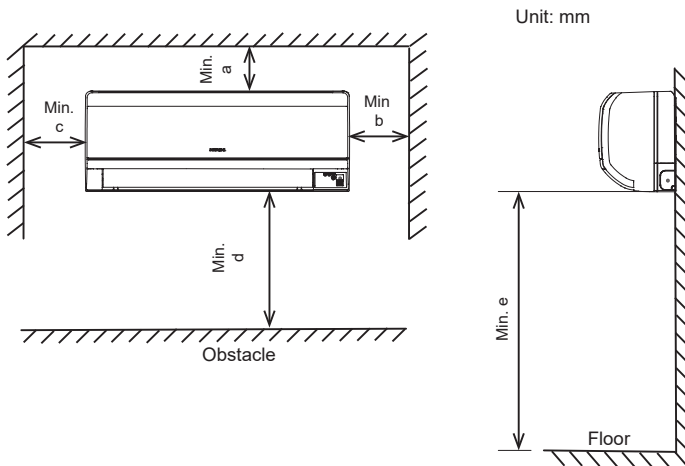

HP	a	b	c	d	e
0.4-1.5	150	100	100	1000	2300
2.0-4.0	100	200	100	1000	2300

- Consider the air distribution from the indoor unit to the space of the room, and select a suitable location so that uniform air temperature in the room can be obtained.
- Avoid obstacles such as electric light, partition which may hamper the air inlet or the air outlet flow.
- In case of using wireless remote controller, do not install the indoor unit within approximately 1 meter from electronic type lighting in order to receive the signal correctly.
- Check to ensure that the ceiling has a sufficient strength to hang the indoor unit. If the strength is insufficient, the vibration or noise may occur during the operation.
- Check whether the wall is vertical and flat.
- Avoid the installation place such as near a door or ceiling where the indoor unit may contact external high humidity. Otherwise, dew may occur and drop.
- Avoid installing the indoor unit where the direct airflow blows from the air outlet to the temperature detecting devices such as an alarm device or a control device. It may cause a failure of an alarm device or a control device.
- UTOPIA Series: The combination for simultaneous operation of indoor units are installed in a same room and required to operate with equal conditions. In the case of these combination indoor unit types, if each indoor unit is partitioned by a wall, furniture or a curtain, etc, it may cause an operation failure. In addition, in the case of rearranging furniture or remodelling an interior after the installation, pay attention to effects for indoor units combination operation.
- Install the indoor unit as high as possible. If it is installed at lower position, the air tends to stagnate downward during the cooling operation. Additionally, the air may flow directly to a person so that may be felt the discomfort.

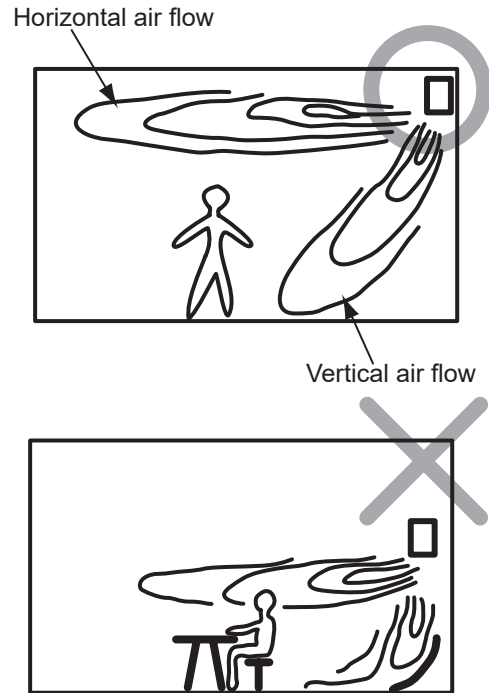

- Do not install flammable parts in the service space for the indoor unit.
- Do not install the indoor unit in a machinery shop or kitchen where vapor from oil or its mist flows to the indoor unit. The oil will deposit on the heat exchanger, thereby reducing the indoor unit performance, and may deform and in the worst case, break the plastic parts of the indoor unit.
- Pay attention to the following points when the indoor unit is installed in a hospital or other facilities where there are electromagnetic waves from medical equipment, etc.
  - Do not install the indoor unit where the electromagnetic wave is directly radiated to the electrical control box, remote control cable or remote control switch.
  - Install the indoor unit and components as far as practical or at least 3 meters from the electromagnetic wave radiator.
  - Prepare a steel box and install the remote control switch in it. Prepare a steel conduit tube and wire the remote control cable in it. Then, connect the ground wire with the box and the tube.
  - Install a noise filter when the power supply emits harmful noises.
- To avoid any corrosive action to the heat exchangers, do not install the indoor unit in an acid or alkaline environment.



### 13.3 INSTALLATION

The dimensions of the suspension bracket (factory-supplied accessory) and the unit installation are indicated in following figures.

◆ **RPK-(0.4-1.0)FSR(H)M (xiii)(\*)**

◆ **RPK-1.5FSR(H)M (xiv)(\*)**

◆ **RPK-(2.0-4.0)FSRM (xv)**

**i NOTE**

(\*): For RPK-(0.4-1.5)FSRHM It is recommended to connect the piping at the right rear side of the body to avoid the sound from the refrigerant running through.

#### 13.3.1 Suspension bracket onto wall

When the suspension bracket is directly attached to a wood wall or a concrete wall, check to ensure that the wall is strong enough to support a weight of 2000N.

#### 13.3.2 Mounting indoor unit between pillars

- 1 Core drill (diameter: 65mm for 0.4-1.5HP, 80mm for 2.0 to 4.0HP) facilitates making hole for pipings.
- 2 Do not install the suspension bracket on one pillar.
- 3 The location where the indoor unit is to be installed should be so selected that an unbalanced weight distribution is avoided.

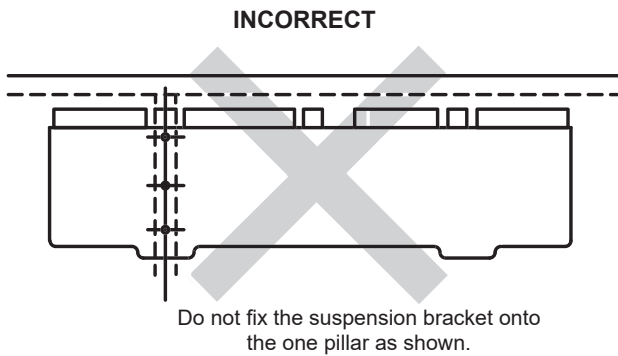

- 4 The suspension bracket should be installed so that the side of drain piping connected is slightly 2 to 3mm lower than the other side, in order to avoid the incorrect position of the drain discharge as shown in the figure below. (Drain piping connection can be performed both right side and left side of the unit.)

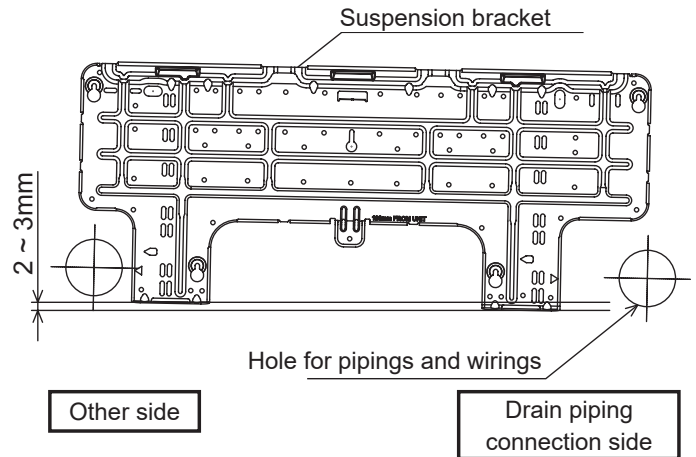

- 5 The piping hole shall be opened slightly lower to the outside as shown in the figure below.

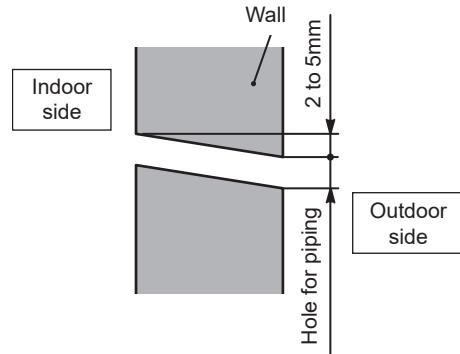

#### ◆ RPK-(0.4-1.5)FSR(H)M

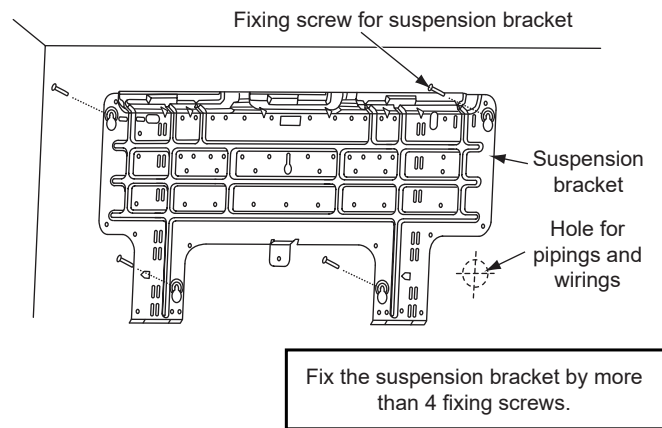

#### ◆ RPK-(2.0-4.0)FSRM

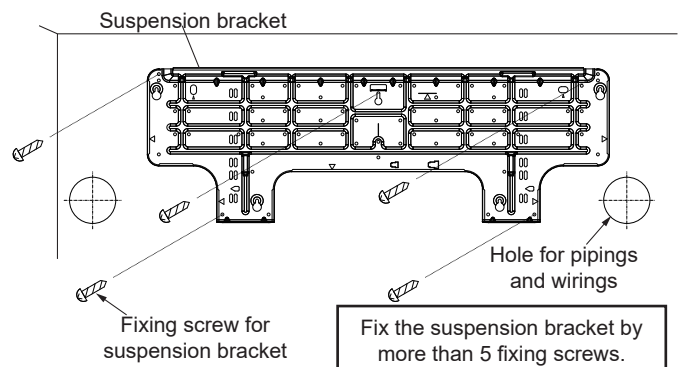

### 13.3.3 Mounting indoor unit on concrete wall or concrete block wall

- Attach the suspension bracket to a concrete wall or a concrete block wall with screws and plugs. Fix the suspension bracket directly to the wall by field-supplied plug as shown in the figure below. The plug depth shall be referred to the manufacturer. The plug size shall be selected from the table below.

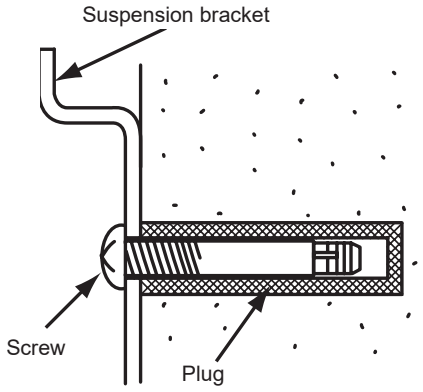

Plug size	Quantity	
	RPK-(0.4-1.5)FSR(H)M	RPK-(2.0-4.0)FSRM
M4-M5	4	5

### 13.3.4 Mounting indoor units

#### CAUTION

Avoid attaching the refrigerant or the refrigerant oil to the upper part of indoor unit. Otherwise, it will be damaged the indoor unit cover and it may cause falling of indoor unit. If the refrigerant or the refrigerant oil is attached, wipe it off completely.

- Hook the upper part of the indoor unit to the suspension bracket.
- Insert the catches at lower part of indoor unit to the cutouts at the suspension bracket.

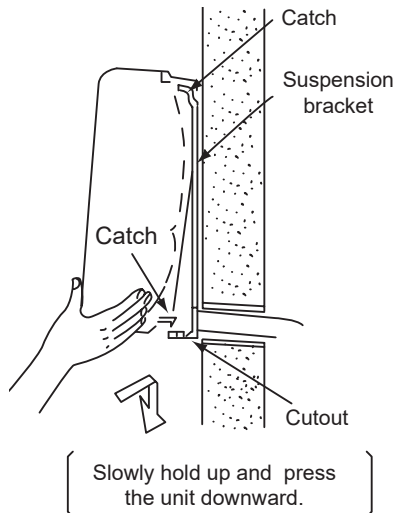

When removing the indoor unit, push up the "PUSH" part on the bottom side and pull the unit to the front side. Therefore, the catches are released from the suspension bracket.

#### CAUTION

Check to ensure that the unit is completely hooked onto the suspension bracket. If not, it may cause vibration of indoor unit. Additionally, the indoor unit may drop from the suspension bracket resulting in a serious accident.

### 13.3.5 Removing flat panel

If the flat panel is needed to be removed, perform according to the following instructions. Pay attention to the resin components not to scratch.

#### ◆ RPK-(0.4-1.5)FSR(H)M

- Removing flat panel
  - Hold both sides of flat panel and open it fully. (xvi)
  - Lift up the air filter, detach the catches from the indoor unit and remove the air filter downward.
  - After the right arm shaft is expanded outward and the shafts are removed from the front panel, pull the flat panel forward while the right arm shaft is slightly expanded outward.

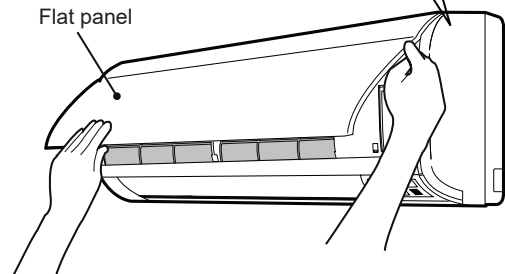
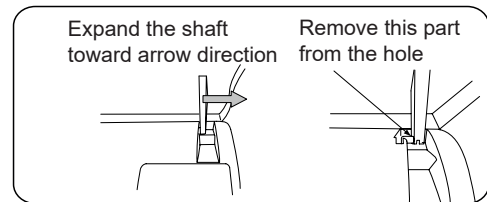

#### 2 Attaching flat panel

Insert completely the left and right arm shafts of flat panel into the holes along the guide at the front panel. After the flat panel is attached completely, insert the catches for air filter to fix.

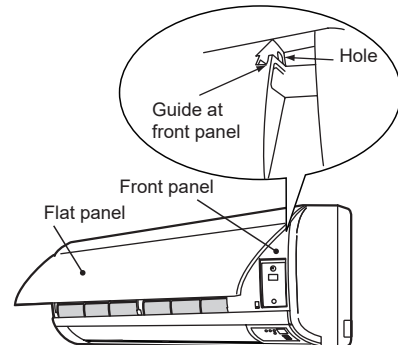

◆ RPK-(2.0-4.0)FSRM

1 Removing flat panel

- a. Hold both sides of flat panel and open it fully. (xvi)
- b. Lift up the air filter, detach the catches from the indoor unit and remove the air filter downward.
- c. After the right arm shaft is pushed inward and the shafts are removed from the front panel, pull the flat panel forward while the right arm shaft is slightly pushed inward.

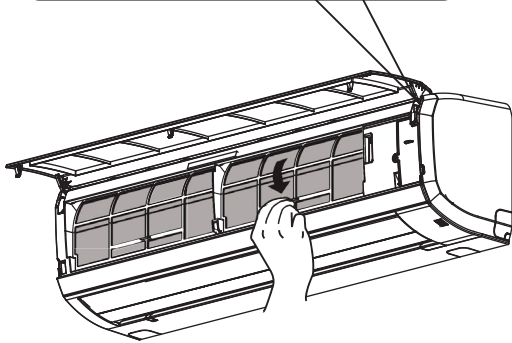
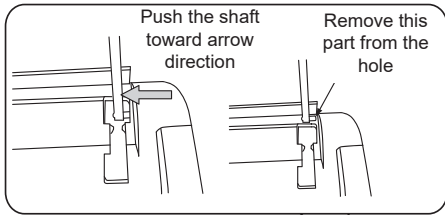

2 Attaching flat panel

Insert completely the left and right arm shafts of flat panel into the holes along the guide at the front panel. After the flat panel is attached completely, insert the catches for air filter to fix.

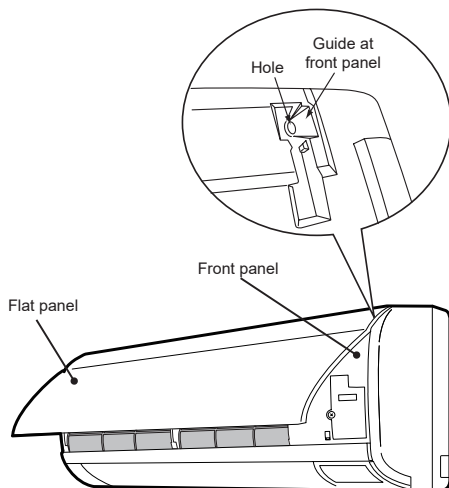

13.3.6 Position of piping connection

Piping direction for the indoor unit. Four directions of piping connection to the indoor unit can be performed; to the rear side, the bottom side, the right side and the left side of the unit. Therefore, most appropriate piping for a room can be selected.

**i** NOTE

For RPK-(0.4-1.5)FSRHM It is recommended to connect the piping at the right rear side of the body to avoid the sound from the refrigerant running through.

13.3.6.1 Direction of piping installation

Determine the direction of the piping connection according to the layout of the installation site. In case that the pipe is connecte toward the side, remove the "knock-out" panel on the side for the piping. Do this before the unit is mounted onto the wall.

Direction of piping connection is shown in the figure below.

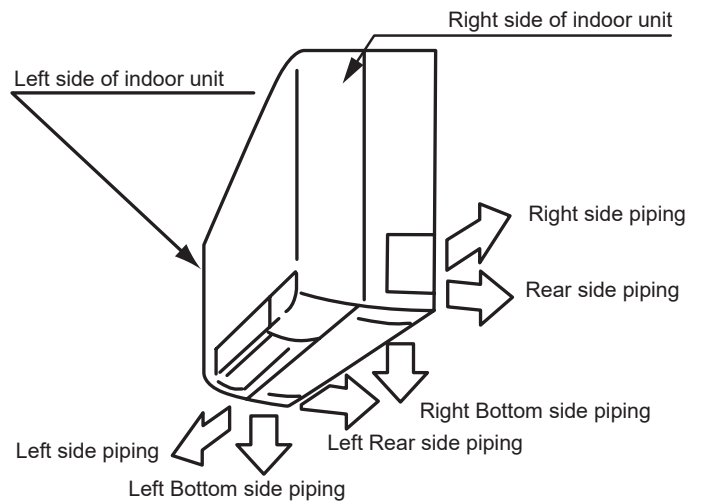

• Right Side Piping

Cut the corner by plastic cutter as shown below and remove sharp edge completely.

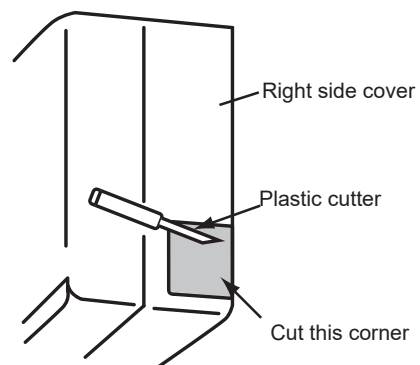

**⚠ CAUTION**

When removing front panel, do not apply an excessive force by hitting, etc. It may break the unit body.



**For bottom side piping**

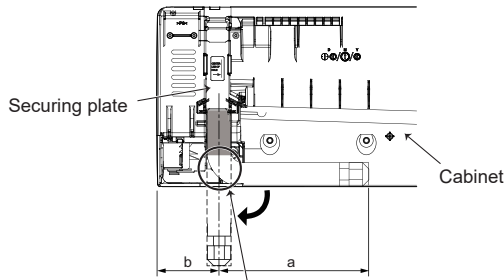

Use the refrigerant pipe after putting this part into the straight position

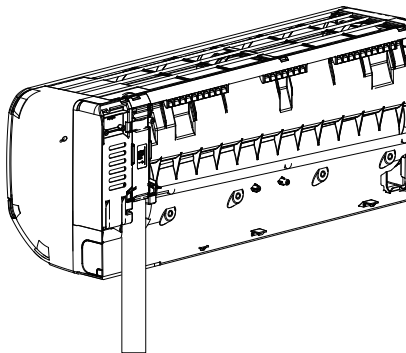

**For installing securing plate (only 2.0 to 4.0 HP)**

Bend the pipe, place it in the bottom space on the rear side of the unit and secure the pipe to the securing plate with band (field-supplied).

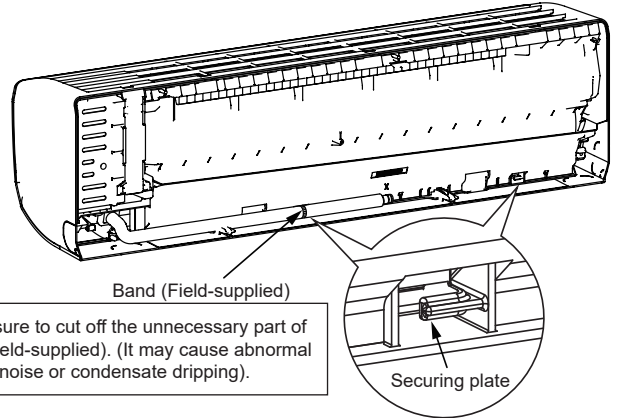

Make sure to cut off the unnecessary part of band (field-supplied). (It may cause abnormal noise or condensate dripping).

**i NOTE**

Make sure to seal a hole in the wall completely in order to prevent rainwater and outdoor air from entering. When using putty for sealing, avoid contact with the wall since it may result in oil stain.

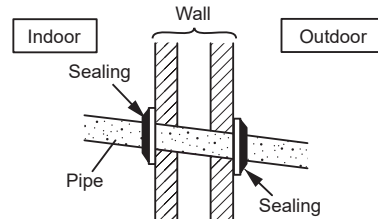

Unit: mm

HP Dimension	0.4 to 1.0		1.5		2.0		2.5 to 4.0	
	Liquid Piping	Gas Piping	Liquid Piping	Gas Piping	Liquid Piping	Gas Piping	Liquid Piping	Gas Piping
a	450	395	450	395	410	350	410	350
b	107	107	107	107	120	120	120	120
c	343	288	343	288	290	230	290	230

**14 REFRIGERANT PIPING WORK**

For the refrigerant piping work, vacuum pump and refrigerant charge, the details shall be referred to “Installation and Operation Manual” of the outdoor unit.

**i NOTE**

For RPK-(0.4-1.5)FSRHM

- The optional expansion valve kit is required for the refrigerant piping work. Refer to the “Installation and Operation Manual of the Expansion Valve Kit” for refrigerant piping procedures, pipe sizes, additional refrigerant charge and the number of connectable units.
- The temperature of the liquid piping between the expansion valve kit and the indoor units becomes lower than the standard indoor units. Additional insulation work should be required for the liquid piping depending on the operating conditions.

### 14.1 PIPING MATERIALS

- 1 The tolerance of refrigerant piping length differs depending on the combination with the outdoor unit. The details shall be referred to "Installation and Operation Manual" of the outdoor unit.
- 2 Select the piping size from the following table.

Unit: mm

Model	Gas piping	Liquid piping
RPK-(0.4-1.5)FSR(H)M RPK-2.0FSRM	Ø12.7 (1/2)	Ø6.35 (1/4)
RPK-(2.5-4.0)FSRM	Ø15.88 (5/8)	Ø9.52 (3/8)

**i** **NOTE**

In the case of installing the wall type without expansion valve, the size of the pipe between the indoor unit and the expansion valve differs depending on the connected outdoor unit. Refer to "installation & maintenance manual" of expansion valve kit for details.

- 3 Prepare field-supplied copper pipes.
- 4 Select clean copper pipes. Make sure there is no dust and moisture inside.
- 5 The refrigerant oil which tends to be affected by foreign matters such as moisture, oxide film, fat. Perform the installation work with care not to enter moisture, dust or old refrigerant into the refrigerant cycle, otherwise the parts such as expansion valve bite foreign matter and the operation may be unavailable.
- 6 Use a pipe cutter to avoid a grind swarf generation for the pipe cutting work. (Do not use a saw or a grind stone to cut pipes.) Blow the inside of the pipes with nitrogen or dry air, to remove any dust or foreign materials before connecting pipes.

When installing pipe through the wall, secure a cap at the end of the pipe.

**Correct**

Hole

Attach a cap or vinyl tape

**Incorrect**

Hole

Do not place the pipe directly on the ground.

**Correct**

Attach a cap or vinyl tape

**Incorrect**

**Correct**

Attach a cap or vinyl bag with rubber band

**Incorrect**

Rain water can enter

### 14.2 PIPING CONNECTION

**!** **CAUTION**

Avoid attaching the refrigerant or the refrigerant oil to the upper part of indoor unit. Otherwise, it will be damaged the indoor unit cover and it may cause falling of indoor unit. If the refrigerant or the refrigerant oil is attached, wipe it off completely.

- 1 Perform the flaring work as shown below.

mm (in.)	
Diameter (Ød)	+0 A -0.4
6.35 (1/4)	9.1
9.52 (3/8)	13.2
12.7 (1/2)	16.6
15.88 (5/8)	19.7

- 2 Use specific flare nut.
- 3 Check that there are no scratch, swarf, deformation, gap, etc. at the flaring part.
- 4 Apply the refrigerant oil in a thin layer to the inside of the

flaring part of the pipe before tightening the flare nut. And the flare nut must be tightened using two spanners according to the tightening torque as shown in the figure below. The tightening work will be easier if tightening the flare pipe in order of the liquid pipe, the gas pipe. Check the leakage of the refrigerant after the tightening work.

**i** **NOTE**

Refrigerant oil according to the outdoor unit specification.

Apply refrigerant oil

Do not apply the refrigerant oil to the outside of the flaring part

Required tightening torque	(JIS B8607)
Pipe size	Tightening torque
Ø6.35 (1/4)	14 - 18 (N-m)
Ø9.52 (3/8)	34 - 42 (N-m)
Ø12.7 (1/2)	49 - 61 (N-m)
Ø15.88 (5/8)	68 - 82 (N-m)

**CAUTION**

Tighten the flare nuts according to the specified torque. If not, it may cause the refrigerant leakage.

- 5 When on-site piping with joint such as elbow, socket is buried, provide a service access door to facilitate the check for connecting part.
- 6 Perform to support for earthquake resistant to the pipes in order not to damage by an external force.
- 7 Do not clamp tightly the refrigerant pipe when supporting for prevention of heat stress.
- 8 Do not touch the refrigerant pipes to low strength portions of walls or ceilings. If not, it may cause abnormal sound or vibration.
- 9 Perform the air tight test. The air tight procedures should be performed according to "Installation and Operation Manual" of the outdoor unit.
- 10 Insulate each flare connection without gap to prevent of dew condensation by using the accessory thermal insulation pipe. Additionally, insulate field gas and liquid pipings by using field-supplied thermal insulations.

**Insulation for Indoor Piping Connection**

Wrap the accessory thermal insulation pipe around the flare

connection and fix it by tape as shown in the figure below:

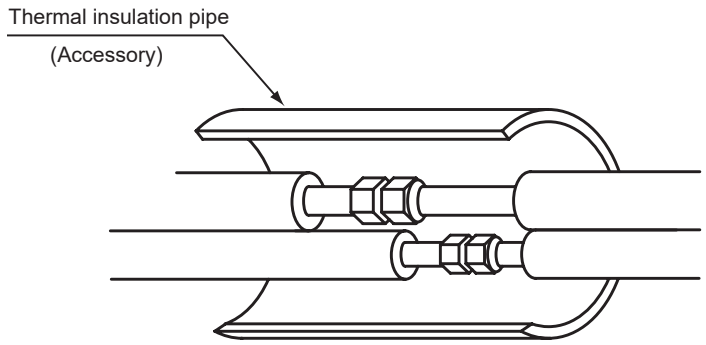

11 For left side piping perform the following piping connection work.

- a. It is recommended that the piping connection work be performed by 2 people: one supports the indoor unit and another performs the piping connection.
- b. Correctly position piping before installing the indoor unit to the wall. For left-rear side piping connections refer to section "15.3.6 Position of piping connection"

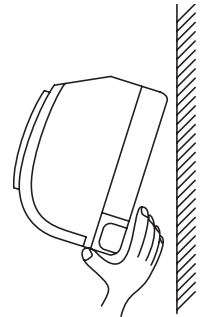

**CAUTION**

- Pay attention not to unhook the indoor unit from the suspension bracket.
- Do not apply excessive force to the flare nut when tightening. If applied, the flare nut may crack due to aged degradation and refrigerant leakage may occur. Use the specified tightening torque.

**15 DRAIN PIPING**

**DANGER**

Do not insert the drain pipe for the indoor unit to the drainage trench where corrosive gases occur. Poisonous gases flow into the room, so that may cause the poisoning.

**NOTE**

- Do not create an upper-slope or rise for the drain piping, since drain water can flow back to the indoor unit and leakage into the room will occur when the system operation is stopped.
- Do not connect the drain pipe with sanitary or sewage piping or any other drainage piping.
- When the common drain piping is connected with other indoor units, the connected position of each indoor unit must be higher than the common piping. The pipe size of the common drain pipe must be large enough according to the unit size and number of units.
- After performing drain piping work and electrical wiring, check to ensure that water flows smoothly as in the following procedure.

1 The standard direction of drain piping connection is rear side as viewed from the discharge grilles. However, it can be performed from the left side of the unit

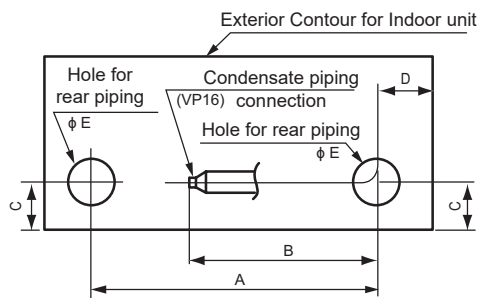

Unit: mm

HP Dimension	0.4 to 1.0	1.5	2.0 to 4.0
A	638	657	925
B	568	568	550
C	45	45	51
D	107	107	120
E	65	65	80

- 2 When the left side drain piping connection is performed, remove the cap of left side drain pipe, and then attach this cap to the right side drain pipe in order to change drain piping connection from right side to left side. If the cap is fixed tightly, remove the cap by using the plier. (Perform this procedure before the indoor unit is hung onto the wall.)

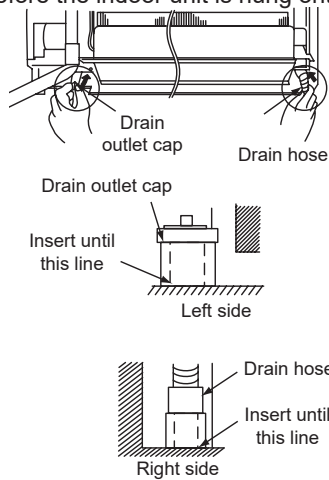

### 3 Connecting drain piping

- Provide a PVC piping with 16 mm outer diameter or locally approved equivalent for the application.
- When the drain hose is used, do not create rising part or twist.

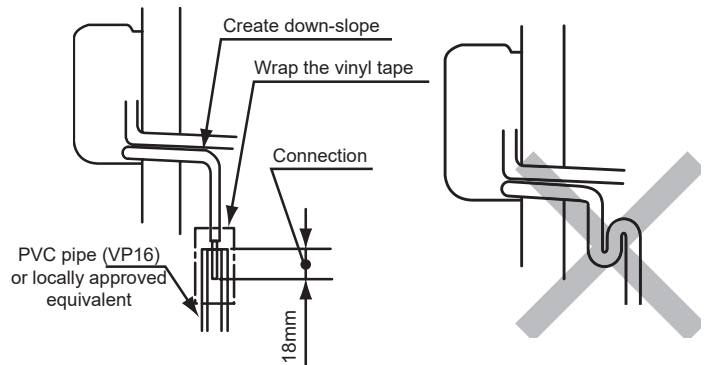

- Wrap surely the vinyl tape around the drain piping connection.
  - Insulate surely the drain pipe after the vinyl chloride pipe connection is completed.
- Do not connect the drain pipe with sanitary or sewage piping or any other drainage piping.
  - After the drain piping work is completed, check that water flows smoothly by pouring water into the drain pan by a cup.
  - Wrap the field-supplied insulation around the drain pipe running through the indoor.
  - When installing the pipe, do not tie the drain pipe and refrigerant pipe together.

### ⚠ CAUTION

- Pay attention not to splash water to the electrical parts such as the fan motor or thermistors.
- When the common drain piping is connected with other indoor units, the connected position of each indoor unit must be higher than the common piping. The size of common drain pipe must be large enough according to the unit size and number of units.

## 16 ELECTRICAL WIRING

### ⚠ DANGER

- The electrical wiring work must be performed by authorized installers. If not, it may cause an electric shock or a fire.
  - Perform the electrical work according to each regulation of region and "Installation and Operation Manual", and the dedicated electrical circuit must be used. If not performing the electrical wiring work completely or a capacity shortage of the power circuit, it will cause an electric shock or a fire.
  - Use the specified cables for wiring between the outdoor unit and indoor units. Selecting incorrect cables will cause an electric shock or a fire.
  - Install an ELB (Earth Leakage Breaker) and CB (Circuit Breaker) in the power source. If not used, it will cause an electric shock or a fire.
  - Turn OFF the main power switch of the indoor unit and the outdoor unit before an electrical wiring work or a periodical check is performed. If not, it will cause an electric shock or a fire.
  - Turn completely OFF the power source to prevent an electrical shock when opening the service cover to perform the electrical work or the maintenance.
  - Check to ensure that the indoor fan and the outdoor fan have stopped before electrical wiring work or a periodical check is performed.
  - Protect the wires, drain pipe, electrical parts, etc. from rats or other small animals. If not protected, rats may gnaw at unprotected parts and at the worst, a fire will occur.
- Tighten screws according to the following torque.  
M3.5: 1.2 N-m  
M4: 1.0 to 1.3 N-m
  - Connect earth wires for the outdoor / indoor unit to prevent an electrical shock or an unexpected accident. The earth resistance must be less than 1 megohm. The earth work must be performed by authorized installers.
  - Pay attention not to bite electrical wirings when attaching the service cover. It may cause an electrical shock or fire.



## ⚠ CAUTION

- Wrap the accessory packing around the wires, and plug the wiring connection hole with the seal material to protect the product from any condensate water or insects.
- Lead the wires through the knockout hole in the side cover when using conduit.
- The procedure of the wiring work shall be performed according to this manual and "Installation & Operation Manual" of the outdoor unit.
- Connect correctly the power source line phases.  
3-Phase 4 Wires: L1, N, 3-Phase 3 Wires: L1, L2
- In the case of 3-Phases 4 Wires type. The power source must be applied from L1 line and N line. If applied from L1-L2, L1-L3, the electrical parts will be damaged.

- The control cable between the indoor unit and the outdoor unit does not have any polarity. Do not apply an excessively high voltage to the cable (Rated Voltage 5V). It may cause failure.
- The remote control switch cable (Field-Supplied) does not have any polarity. Do not apply an excessively high voltage to the cable (Rated Voltage 5V). It may cause failure.
- Maintain the rated voltage for the power source. It may be harmful to the unit if the voltage is either too high or too low.
- Take enough capacity for the power source. If not, the operation can not be started by the wide voltage reduction.
- The expansion valve kit should be used for "indoor unit wall type without expansion valve" installation together. Refer to the "Installation and Operation Manual of the Expansion Valve Kit" for wiring procedures.
- The expansion valve kit (sold separately as an option) installation work should be completed before turning on the power for the indoor unit side.

## 16.1 GENERAL CHECK

- 1 Make sure that the field-selected electrical components (main power switches, circuit breakers, wires, conduit connectors and wire terminals) have been properly selected according to the electrical data given in "Technical Catalog". Make sure that the components comply with National Electrical Code (NEC).
- 2 Check to ensure that the power supply voltage is within  $\pm 10\%$  of the rated voltage.
- 3 Check the capacity of the electrical wires. If the power source capacity is too low, the system cannot be started due to the voltage drop.
- 4 Check to ensure that the earth wire is connected.
- 5 Do not operate the system until all the check points have been cleared.
  - a. Check to ensure that the electrical resistance is more than 1 megohm, by measuring the resistance between ground and the terminal of the electrical parts. If not, do not operate the system until the electrical leakage is found and repaired.
  - b. Check to ensure that the stop valves of the outdoor unit are fully opened, and then start the system.
  - c. Check to ensure that the switch on the main power source has been ON for more than 12 hours, to warm the compressor oil by the crankcase heater.
- 6 Do not touch any of the parts by hand at the discharge gas side while the system is running, since the compressor chamber and the pipes at the discharge side are heated higher than 90°C.

## 16.2 ELECTRICAL WIRING CAPACITY

### 16.2.1 Field minimum wire sizes for power source

Model	Power source	Maximum current	Power source cable size	Transmitting cable size
			EN 60335-1 *1	EN 60335-1 *1
RPK-(0.4-4.0)FSR(H)M	1~ 220-240V 50/60Hz	5A	0.75mm <sup>2</sup>	0.75mm <sup>2</sup>

## **i** NOTE

- Follow local codes and regulations when selecting field wires.
- The wire sizes marked with \*1 in the above table are selected at the maximum current of the unit according to the European Standard, EN 60335-1. Use the wires which are not lighter than the ordinary tough rubber sheathed flexible cord (code designation 60245 IEC 57) or ordinary polychloroprene sheathed flexible cord (code designation 60245 IEC 57).
- In the case that power cables are connected in series, add each unit maximum current and select wires below:

Selection according to EN 60335-1	
Current i (A)	Wire size (mm <sup>2</sup> )
$i < 6$	0.75
$6 < i < 10$	1
$10 < i < 16$	1.5
$16 < i < 25$	2.5
$25 < i < 32$	4
$32 < i < 40$	6
$40 < i < 63$	10
$63 < i$	In the case that current exceeds 63A, do not connect cables in series.

- Use the shielded twisted pair cable for control between the outdoor unit and the indoor unit, the control cable between indoor units and the remote control switch cable.

## 16.2.2 Harmonics

In relation to IEC 61000-3-2, the situation of harmonics for each model is as follows:

Situation of the models in relation to IEC 61000-3-2 Ssc "xx"	Model
Equipment complying with IEC 61000-3-2	RPK-0.4FSRM RPK-0.4FSRHM RPK-0.6FSRM RPK-0.6FSRHM RPK-0.8FSRM RPK-0.8FSRHM RPK-1.0FSRM RPK-1.0FSRHM RPK-1.5FSRM RPK-1.5FSRHM RPK-2.0FSRM RPK-2.5FSRM RPK-3.0FSRM RPK-4.0FSRM

## 16.2.3 Details of electrical wiring connection

The electrical wiring capacity of the outdoor unit should be referred according to "Installation & Operation Manual" of the outdoor unit. Setting dip switch may be required depending on the combination with the outdoor unit.

- 1 Connect the power source cables (L1 and N (L2) phases (1~ 220-240V 50/60Hz)) to the terminal board correctly.

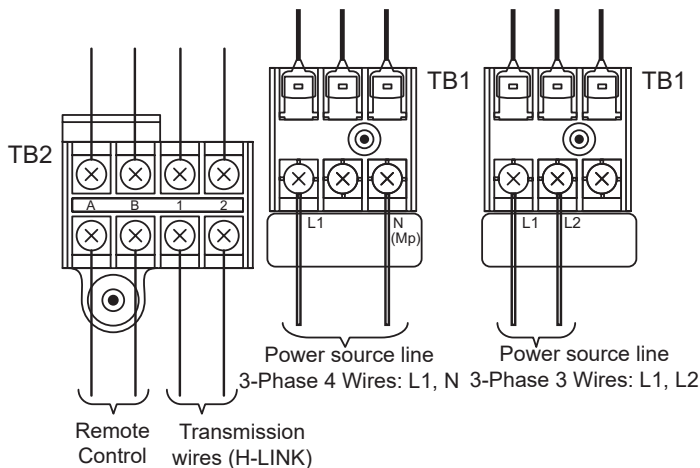

- 2 Connect the control cables between the indoor unit and the outdoor unit correctly.
- 3 Check to ensure that the terminal for power source cable (Terminals "L1" to "L1" and "N(L2)" to "N(L2)") of each terminal board (1~ 220-240V 50/60Hz) between the indoor unit and the outdoor unit coincide correctly. If not, some component will be damaged.
- 4 Use shielded twisted pair cable for the control cable between the outdoor unit and the indoor unit, between indoor units. They are connected to the terminals 1 and 2 of the terminal boards. The total cable length should be less than 1000m.
- 5 Use shielded twisted pair cable for the remote control switch cable. The total cable length should be less than 500m. If the total length of the cable is less than 30m, other cables can be used (0.3 to 0.75mm<sup>2</sup>) if comply with local regulations.

The remote control shielded twisted pair cable is connected to the terminals A and B of each indoor unit terminal board.

- 6 Check to ensure that the communication cable between outdoor unit and indoor units (H-Link), comply with Local regulations and it is not affected by any electromagnetic noise. It must be a shielded twisted pair cable ( $\geq 0.75\text{mm}^2$ ) with a total H-Link length  $< 1000\text{m}$ .
- 7 Control cable: connect the both ends of shielded twisted pair cable to the earth as shown.

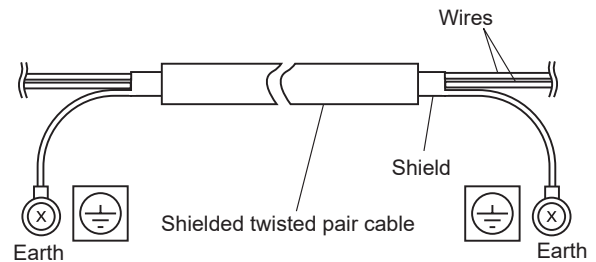

- 8 Remote control switch cable: Connect the one end of shielded twisted pair cable to the earth as shown.

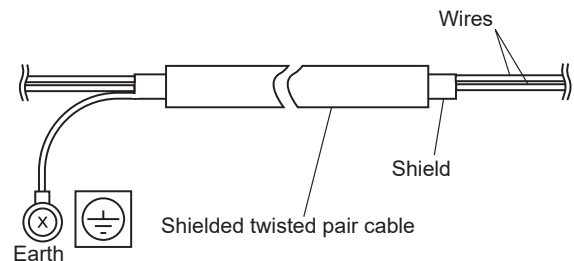

- 9 When installing the unit in Australia, a lockable isolator shall be mounted adjacent to but not on the units and will disconnect all active conductors to the unit from the supply circuit.

### **⚠ DANGER**

- **Tightly secure wirings to the terminal board according to the specified torque. If tightening the terminals is not completed, heat generation, an electric shock or a fire will occur at the terminal connection.**
- **Make sure that the wires are securely fixed in order not to apply an external force to the terminal connections of the wirings. If fixing is not completed, heat generation or a fire will occur.**
- **Fix the terminals that do not touch to the electrical box surface. If the terminals are closed to the surface, it may cause activation of ELB, heat generation at terminal connection, a fire or an electric shock.**
- **Select the wiring size, ELB (Earth Leakage Breaker) and isolating switch according to each regulation of region and "Installation & Operation Manual", and the dedicated electrical circuit must be used.**

**CAUTION**

- Separate the power supply wiring from the terminal block for controller and communication cables (TB2).
- Do not connect the main power source cables to the control line (Terminals A, B, 1 and 2 of TB2). If connected, the printed circuit board (PCB) will be broken.
- Pay attention to followings when wires are connected to terminal board:

- (A) Attach an insulation tape or a sleeve to each terminal.
- (B) Maintain the distance between the electrical box and the terminals to prevent a short circuit.
- (C) Maintain the distance between the terminals.

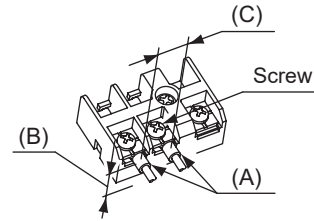

- Check the recommended size of the ELB shown in table. Select high-sensitive high speed ELB when the rated sensitive current is less than 30mA. (The motion time should be within 0.1 second.)
- The use of a cable other than that specified above can cause of malfunction due to effects of noise

**◆ For UTOPIA Series**

Model	ELB	Main switch		Wiring size (mm <sup>2</sup> )						
		n / A / mA	Rated current (A)	Fuse capacity (A) or CB	Power source cable	Transition wiring between O.U. and I.U.		Transition wiring between indoor units *6	Earth wiring *7	Remote control switch cable *8
						Power supply	Control Circuit *5			
Single type	2 / 40 / 30	5	5	1.0	1.0	0.75	-	2.0	0.75	
Multi type							0.75			3.5

ELB: Earth Leakage Breaker; CB: Circuit Breaker; I.U.: Indoor unit; O.U.: Outdoor unit

**i NOTE**

For the total wiring length more than 20m, refer to "Installation & Operation Manual" of the outdoor unit.

**Example of wiring connection combinations for simultaneous operation**

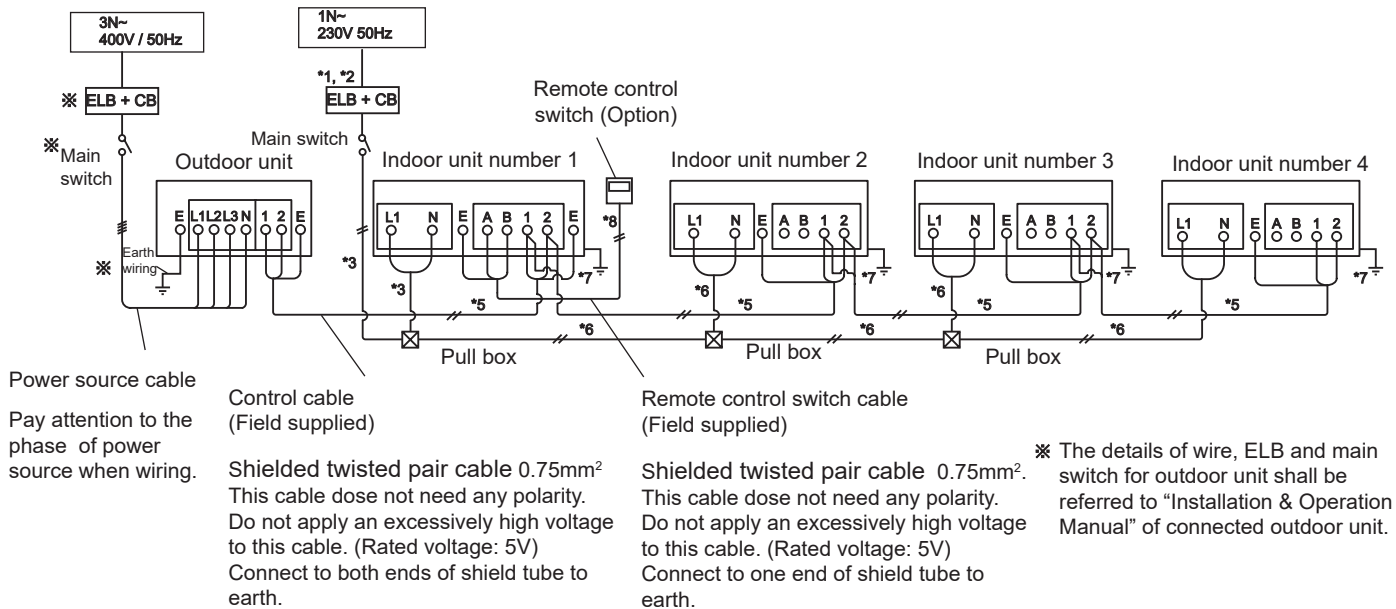

**Example of wiring connection combinations for individual operation**

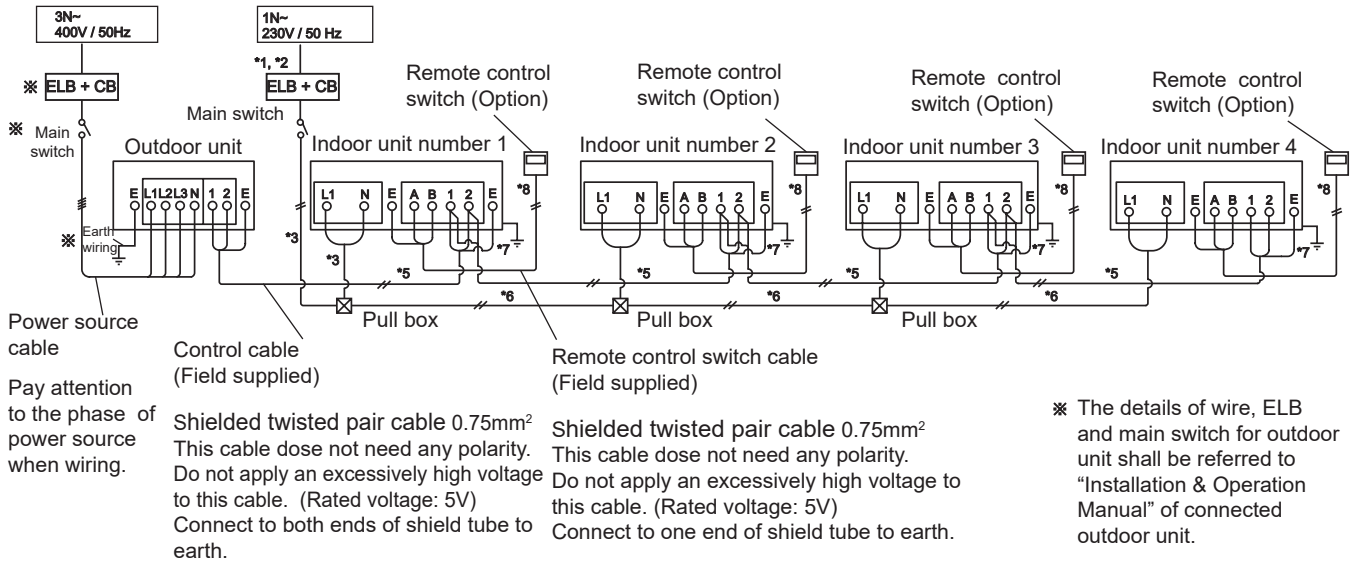

◆ **For SET-FREE Series**

Select wiring capacity according to the following table. Install the ELB and the main switch to each as shown in the figures below.

Total indoor unit capacity	Power Source				Earth wire size (mm <sup>2</sup> ) *12	Transition wire size for control circuit (mm <sup>2</sup> ) *13	Remote control switch cable (mm <sup>2</sup> )	
	ELB n / A / mA	Main Switch		Minimum wire size (mm <sup>2</sup> )				Wiring length (m) <sup>*1</sup> *11
		Switch capacity (A) *10	Fuse capacity (A) or CB *10					
< 7A	2 / 40 / 30	30	15	2.5	30	3.5	Shielded twisted pair cable 0.75 ~ 1.25 Connect to both ends of shield tube to earth.	
<10A		30	20	4.0				
< 15A		30	30	6.0				34

ELB: Earth Leakage Breaker; CB: Circuit Breaker

\*1): The above wiring line length shows the case that the indoor units are connected in series. (The voltage drop is within 2%.) When the power source wiring is longer than the above value, select the minimum wiring size which the voltage drop is within 2%.

**i NOTE**

- On the outside indoor unit, the power source cable, control cable and remote control cable shall be installed separately as possible.
- The dip switches setting in the outdoor unit should be performed according to "Installation & Operation Manual" of the outdoor unit. Pay attention that the transition wiring for the remote control switch is required in the following cases.:
  - a The following functions are set to the sub unit which is not installed the remote control switch.
    - \* "Remote ON/OFF function, 1, 2 and 3" (external input / output function)
    - \* "Power supply ON/OFF function, 1 and 2" (function selection)
    - \* "Prohibiting remote control after manual stoppage" (external input / output function)
    - \* "Group setting by the centralized controller"
  - b The combination of twin, triple or quad is controlled by one remote control switch.
  - c The address of the indoor unit is changed from the remote control switch

**Example of wiring connection Heat pump system**

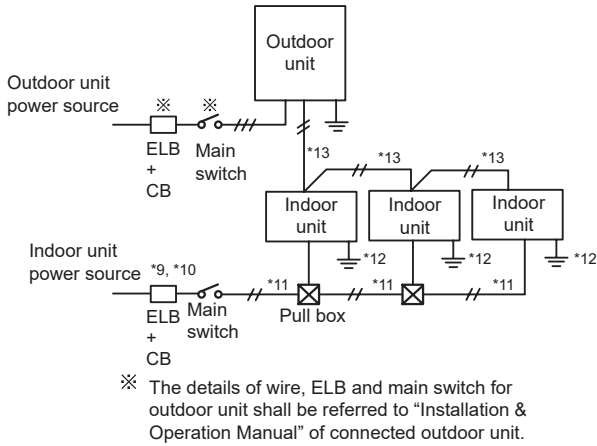

**Example of wiring connection Heat recovery system**

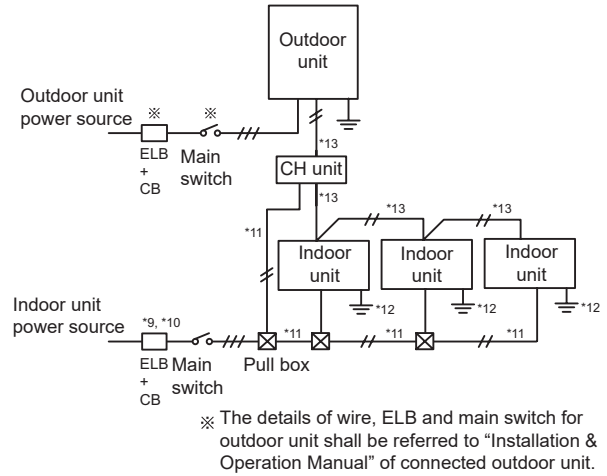

**16.3 WIRING CONNECTION**

The wiring connection of indoor unit is shown below.

- 1 Insert the wires from the rear side of indoor unit as shown in the figure below.

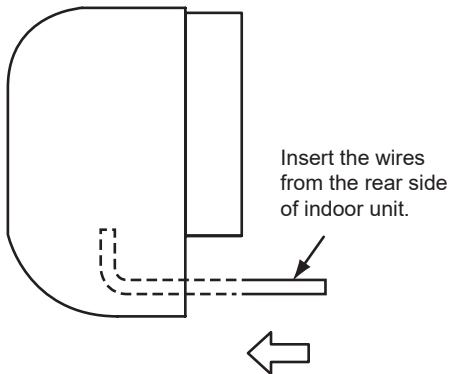

- 2 Position of electrical box cover. The figure below shows that the front panel is removed. The electrical box cover can be opened without removing the front panel.

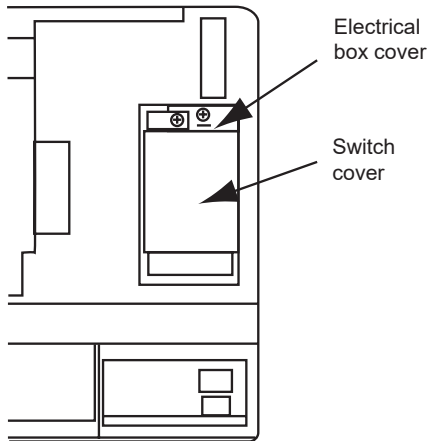

- 3 Open the electrical box cover and perform the field electrical wiring work. Close the electrical box cover after the electrical wiring work is completed.

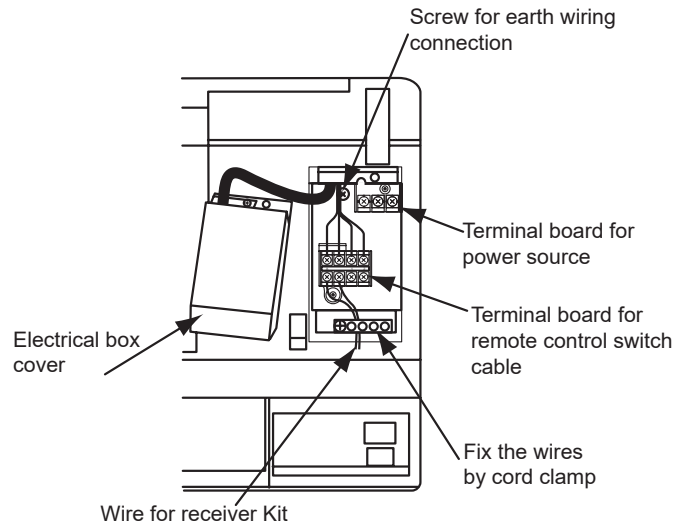

**◆ For RPK-(0.4-1.5)FSRHM**

- 1 The procedure of the wiring connection to the terminal boards is the same with the standard indoor unit.
- 2 The connector (CN33) for the expansion valve kit is fixed at the rear side of the electrical control box with tape. Connect the extension cable of optional expansion valve kit to CN33.

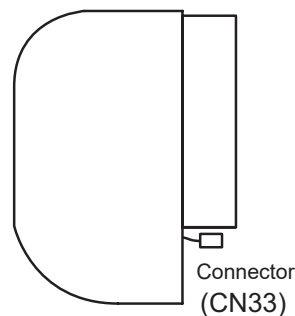

- Securely fix the extension cable (accessory of the optional expansion valve kit) along the refrigerant pipe with tape. At this time, the refrigerant pipe should be positioned between the power source cable and cables for expansion valve kit, remote control switch and transmission in order to prevent malfunction as shown in the figure below.

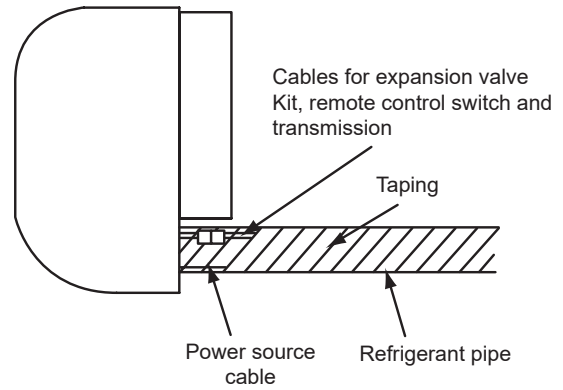

### 16.4 DIP SWITCH SETTING

- Turn OFF all the power supply to the indoor and the outdoor units before dip switch setting. If not, the setting is invalid.

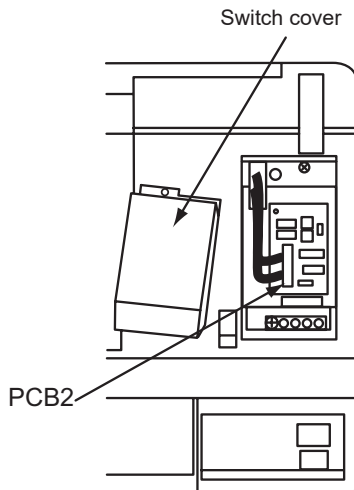

#### Dip Switch PCB (PCB2)

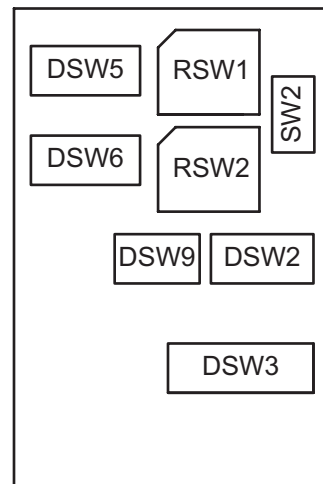

- The positions of dip switches on PCB are shown in the figure below. Open the switch cover. After the dip switches are set, attach the switch cover again.

- RSW2 & DSW6 (Unit Number Setting).** The indoor unit number of all indoor units are not required. The indoor unit numbers are set by the auto-address function. If the indoor unit number setting is required, set the unit number of all indoor units respectively and serially by following setting position. It is recommended that the unit number setting start from "1". For the centralized control, this setting is required.

#### Unit number setting

DSW6 (Tens digit)	RSW2 (Units digit)	Ex.) Set at number 16 Unit
<p>Before shipment, DSW6 and RSW2 are set to "0". Max. 64 units are available to set when all the equipment to be connected are corresponding to H-LINK II. Max. 16 units when the units corresponding/ non-corresponding to H-LINK II are combined.</p>		

- DSW3 (Capacity code setting).** No setting is required, due to setting before shipment. This switch is used for setting the capacity code which corresponds to the Horse Power of the indoor unit.

Horsepower	0.4	0.6	0.8	1.0	1.5	2.0	2.5	3.0	4.0
Setting position									

**5 RSW1 & DSW5 (Refrigerant cycle number setting).** Setting is required. Setting positions before shipment are all OFF.

Refrigerant cycle number setting

<p><b>DSW5 (Tens digit)</b></p>	<p><b>RSW1 (Units digit)</b></p>	<p>Ex.) Set at number 5 cycle</p> <p><b>DSW5</b></p> <p>Set all pins OFF</p> <p><b>RSW1</b></p> <p>Set at "5"</p>
<p>Before shipment, DSW5 and RSW1 are set to "0". Max. 64 cycles are available to set when all the equipment to be connected are corresponding to H-LINK II. Max. 16 cycles when the units corresponding/ non-corresponding to H-LINK II are combined.</p>		

**6 DSW7 (Fuse recovery).** (This dip switch is located on PCB1.)

\* In the case of applying high voltage to the terminal 1 and 2 of TB2, the fuse (0.5A) on the PCB is cut. In such a case, firstly reconnect the wirings correctly to TB2, and then turn on Number 1 pin.

<p><b>Factory setting</b></p>	<p><b>High voltage</b></p>
-------------------------------	----------------------------

**7 DSW2 / DSW9 (Optional function setting).** No setting is required. Setting positions before shipment are all OFF.

<p><b>DSW9</b></p>	<p><b>DSW2</b></p>
--------------------	--------------------

For example, set the number 1 pin of DSW9 to "ON" side when indoor unit C is set as "Identifying indoor units installed side by side".

	Indoor Unit A	Indoor Unit B	Indoor Unit C	Indoor Unit D
DSW2-3	OFF	ON	OFF	ON
DSW9-1	OFF	OFF	ON	ON

Factory setting for DSW2-3 and DSW9-1 is "OFF".

**i NOTE**

When using the receiver kit, setting DSW2 and DSW9 on the PCB for the indoor unit is not required. Set the function "Identifying indoor units installed side by side" with the receiver kit instead. For details on this setting, refer to the "Installation manual" for the receiver kit.

**8 SW2 (Remote control switch setting).** The setting before shipment is "Wireless".

\* In case of using the wired remote control (PC-ARF(P) (1)(E)) and the receiver kit (PC-ALHZ1), set the SW2 to "Wired". If not, the operation is not available. Connect the remote control switch cables to terminals A and B at the terminal board TB2.

<p><b>Factory setting</b></p> <p>Wired </p> <p>Wireless </p>	<p><b>Wired remote control</b></p> <p>Wired </p> <p>Wireless </p>
--	---

**i NOTE**

- The "■" mark indicates position of dip switches. Figures show setting before shipment.
- When the unit number and the refrigerant cycle are set, record the unit number and refrigerant cycle to facilitate maintenance and servicing activities thereafter.
- Turn OFF all the power supply of the indoor unit and the outdoor unit before Dip Switch setting. If not, the setting is invalid.
- In case of using the wired remote control or receiver kit PC-ALHZ1 set the SW2 to "Wired".

**17 TEST RUN**

Test run should be performed according to this manual and "Installation & Operation Manual" of the outdoor unit.

**⚠ DANGER**

- Check to ensure that the electrical resistance is more than 1 megohm, by measuring the resistance between ground and the terminal of the electrical parts. If not, do not operate the system until the electrical leakage is found and repaired.
- Do not touch any of the parts at the discharge gas side by hand while the system is running, since the compressor chamber and the pipes at the discharge side are heated higher than 90°C.

**⚠ CAUTION**

- Supply electrical power to the system for approximately 12 hours before start-up after long shutdown. Do not start the system immediately after power supply, it may cause a compressor failure, because the compressor is not heated well.

**i NOTE**

- Check to ensure that the stop valves of the outdoor unit are fully opened, and then start the system.

## 17.1 BEFORE TEST RUN

Recheck that there is not any problems to the installation, and do not perform the test run until all the following checking points have been cleared.

- 1 Check to ensure that the refrigerant piping and the transition wiring are connected to the same refrigerant cycle system. If not, it will cause an abnormal operation and breakage of instruments.
- 2 Do not apply the high voltage to the terminals for the transmission (TB2 [A, B, 1 and 2]).
- 3 Check to ensure that each wire is correctly connected at the phase of power source. If incorrectly connected, the unit will not operate and the remote control switch will indicate the alarm code "05". In this case, check the phase of the primary power source according to the attached attention

label on the rear side of the service cover. Then, perform the reconnection work correctly with turning OFF the power supply.

- 4 For wired remote control switch (PC-ARF(P)(1)(E)), set the SW2 to "Wired" because the setting before shipment is "Wireless". If not, the operation is not available.

### NOTE

*The RUN indicator on indoor unit is turned ON even when the wired remote control switch is used. However, the indication for timer settings are only indicated on the wired remote control switch.*

- 5 For the indoor unit wall type without expansion valve, check that the optional expansion valve kit is installed without fail before test run.

## 17.2 START TEST RUN

After the installation work is completed, test run should be performed.

In the case that indoor units are connected to the VRF system, perform the test run of the indoor unit one by one sequentially and then check accordance of the refrigerant piping system

and the electrical wiring system. (If the multiple indoor units are operated simultaneously, the system can not be inspected the system accordance.).

For more information, please refer to remote control "Installation & Operation Manual".

## 18 MAINTENANCE

### DANGER

- Turn OFF the power source before the maintenance work. If not, it may cause a fire or an electric shock.
- Perform the maintenance work with stable footing. If not, it may cause falling or injury.

### CAUTION

*When the flat panel is opened (closed) or the air filter is attached (removed), perform the work according to this operation manual. If not, it may cause falling or injury.*

### NOTE

*Do not operate the system without the air filter to protect the indoor unit heat exchanger against being clogged.*

## 18.1 DAILY MAINTENANCE

### 18.1.1 Cleaning air filter

Clean the air filter when the filter sign is turned ON.

- 1 Open the flat panel.
  - Hold the both sides of flat panel and pull up. (v)
- 2 Remove the air filter.
  - Lift up the air filter, detach the catches from the indoor unit and remove the air filter downward. (vi)
- 3 Clean the air filter.
  - Vacuum the dust by a cleaner, or wash the air filter by water or neutral detergent.
  - Dry the air filter in the shade

### NOTE

- Do not use hot water more than 50°C. The air filter may be deformed by heat.
- Do not dry the air filter by an open fire, a dryer or a heater. The air filter may be deformed.

- 4 Attach the air filter. After the air filter is dried, correctly attach it with "FRONT" indication frontward to the indoor unit.

- 5 Close the flat panel pressing 3 parts.

### NOTE

*Be sure to attach the air filter. If the indoor unit is operated without the air filter, it may cause malfunction of the indoor unit.*

- 6 Reset the filter sign.

### PC-AWR

Point the transmitter toward the receiver and press "RESET"  switch. The filter sign of unit is turned OFF and the next filter cleaning will be accumulated.

### PC-ARF(P)(1)(E)

### NOTE

*If the accumulated time of filter cleaning is not got to setting time, the indication  is turned ON and "Setting disabled" will be displayed.*



- Press “☰” (menu).

Select “Reset filter sign time” from the menu and press “OK”. The confirmation screen will be displayed.

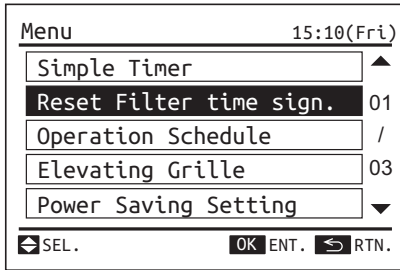

- Select “Yes” by pressing “◀” or “▶” and press “OK”. The indication of “FLTR” will be turned OFF and the screen will return to the normal mode.

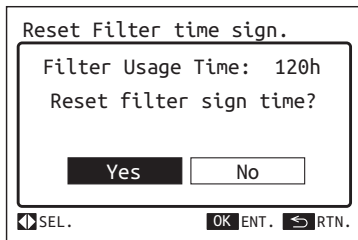

### 18.1.2 Maintenance for flat panel

#### **i** NOTE

- Use a soft cloth to clean the flat panel. If benzene, thinner or detergent (with surfactant) is used to clean, the resin part may be changed color or deformed. In addition, pay attention that the parts around the air outlet (louver, guide, etc.) may be damaged if an excessive force is applied.
- The flat panel can be removed and cleaned. Remove it by both hands.

#### ◆ RPK-(0.4-1.5)FSR(H)M

##### 1 Removing flat panel

Hold both sides of flat panel and open it fully. After the right arm shaft is expanded outward and the shafts are removed from the front panel, pull the flat panel frontward while the right arm shaft is expanded outward.

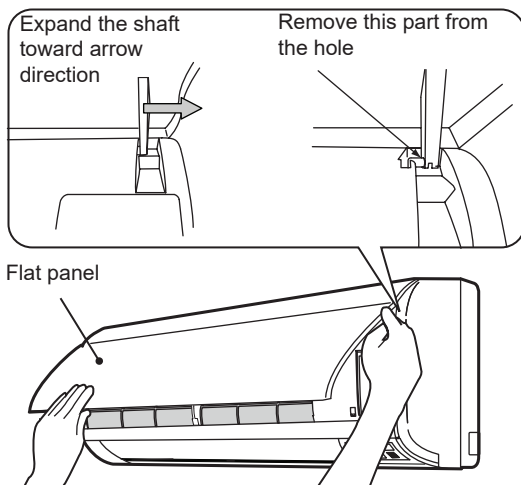

##### 2 Attaching flat panel

Insert completely the left and right arm shafts of flat panel into the holes along the guide at the front panel. After the flat panel is attached completely, insert the catches for air filter to fix.

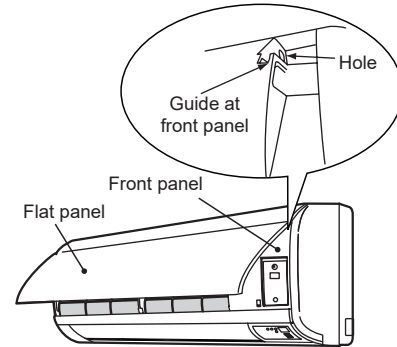

#### ◆ RPK-(2.0-4.0)FSRM

##### 1 Removing flat panel

Hold both sides of flat panel and open it fully. After the right arm shaft is pushed inward and the shafts are removed from the front panel, pull the flat panel frontward while the right arm shaft is slightly pushed inward.

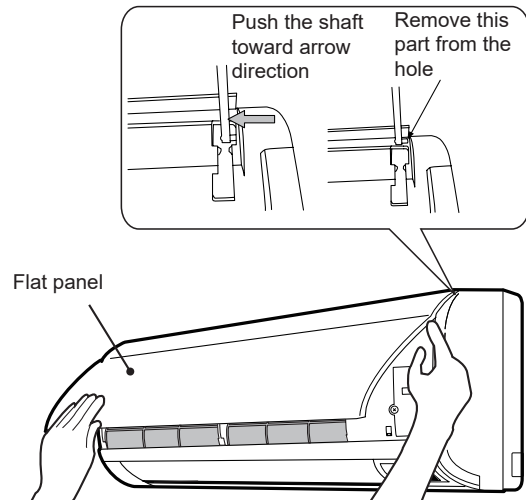

##### 2 Attaching flat panel

Insert completely the left and right arm shafts of flat panel into the holes along the guide at the front panel. After the flat panel is attached completely, insert the catches for air filter to fix.

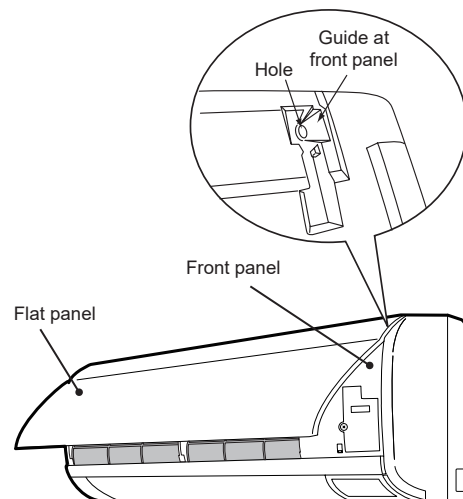

## 18.2 MAINTENANCE BEGINNING AND ENDING OF USE

### Beginning of use

- Remove obstacles for the air inlet grilles of indoor unit and outdoor unit and the air outlet.
- Check that the air filter is not clogged.

### Ending of use

Clean the air filter, the air inlet grille and the flat panel.

## 19 TROUBLESHOOTING

Phenomenon		Cause and action
Operation Stopped	All indication lamps on the wired controller are turned OFF.	The micro-computer is activated to protect the device from electromagnetic waves. Restart the operation.
	After Power Failure	Restart the operation. If the instantaneous power failure is within two seconds, the operation restarts automatically.
White steam from indoor unit	During the heating operation.	It may occur during the defrosting operation in the heating operation.
White smoke from indoor unit	At Beginning of Heating Operation Season	Dust attached to the heat exchanger has been dried.
Mist from indoor unit	The indoor unit is used in a restaurant or a kitchen.	Oil is attached to the fins and the heat exchange efficiency may be decreased.
	During the dry operation	It may occur when the air outlet temperature becomes lower.
	The cooling operation is performed in high humidity environment.	Raise the set temperature and the air flow volume.
Odor from indoor unit	The air flow from the indoor unit has odor.	It may occur because the cigarette smoke and room odor are stuck inside the indoor unit.
		Ventilate well by the fan mode and clean the air filter, the flat panel, the air outlet and the air inlet grille. It may be effective for odor eliminating.
Sound from indoor unit	Sound is heard when starting or stopping the operation.	It is generated because the resin parts are stretched by the temperature change and rubbed with other parts.
	Sound which water flows or is boiled is heard during the operation.	It is generated because the refrigerant flows or the drain-up mechanism drains water. Especially, sound may be heard when starting the operation or stopping the compressor (for approx. 3 minutes).
	Growling sound may be heard temporarily right after the air flow volume is changed.	It is generated because the fan motor makes temporary sound by change of fan speed.
Dew on panel	Dew condensation occurs on the panel or the cabinet or dew drops.	It may occur if the operation is performed in high humidity place (relative humidity is approx. 80%.) for a long time.
Temperature Irregularity	The air flow volume and temperature of each air outlet are irregular.	This might occur for structural reasons, such as the size of air outlet and the location of heat exchanger.
Turned ON "HOT-ST" on LCD		The indications may be turned ON or flash according to the operation mode or condition.
Flashing operation mode on LCD		

Trouble		Checking point	Action
Not operated		Check that the main power source is turned ON.	Turn ON the main power source for air conditioner.
		Check that the fuse does not blow out or the circuit breaker of main power source is not tripped.	Replace the fuse or reset the circuit breaker. If the trouble recurs, contact your contractor or distributor.
Operated however, stopped soon	Cooling	Check whether the air inlet and outlet of the outdoor unit are not covered by a paper, a vinyl or other object.	Remove objects covering the air inlet and outlet.
		Check whether there are any obstacles for the air flow near the air inlet and outlet of the outdoor unit.	Remove the obstacles which prevent the air flow.
	Heating	Check whether the outlet air is short-circuited to the air inlet.	

Trouble	Checking point	Action
Not cooling or heating well	Check that the operation mode is appropriate.	If the fan mode is selected, switch the operation mode to cooling (heating).
	Check that the set temperature is appropriate.	If not, change the set temperature by pressing “▲” or “▼” by the remote control switch.
	Check that the air flow direction is appropriate.	If not, change the air flow direction. In the case that the footing is not heated well during the heating operation, change the louver downward.
	Check that the air filter is not clogged.	Clean the air filter.
	Check that a window and a door are not opened.	Close the window and the door.
	Check that there are no obstacles for the air inlet and the air outlet of the outdoor unit and the indoor unit.	Remove the obstacles.

## 19.1 CONTACT DISTRIBUTOR

If the trouble still remains even after checking previous items or other troubles not mentioned in the previous occurs, stop using the product and contact your distributor or contractor.

Trouble	Action before contact
The protection devices (fuse, breaker, ELB, etc) are frequently activated or the main power source switch does not work.	Turn OFF the power source.
Water leakage from indoor unit.	Stop the operation.
<p>◆ <b>PC-ARF(P)(1)(E)</b></p> <p>The RUN indicator (red) is flashing.</p> <p>The indoor unit number, the alarm code, the unit model code and the connected number of indoor units are displayed on LCD.</p> <p>In case that the plural indoor units are connected to one remote control switch, the above abnormality informations for each indoor unit are displayed one by one</p> <p>Check the details on LCD and contact your distributor.</p> <p>(vii)</p> <p>◆ <b>PC-AWR</b></p> <p>For the wireless remote control switch, the alarm codes are indicated by the flashing times of indicator on indoor unit.</p>	<p>Refer the alarm code table.</p> <p>Contact your distributor and inform the indication detail on the remote control switch.</p>

Inform the following items to a distributor.

- 1 Unit model.
- 2 Content of trouble.
- 3 Alarm code No. on LCD or detail of flashing indicator.

## 19.2 MAIN ALARM CODES

Code	Category	Content of abnormality
01	Indoor unit	Activation of protection device (float switch)
02	Outdoor unit	Activation of protection device (high pressure cut)
03	Transmission	Abnormality between indoor and outdoor
04		Abnormality between Inverter PCB and outdoor PCB
05	Supply phase	Abnormality power source phases
06	Voltage	Abnormality of voltage drop in outdoor unit
07	Cycle	Decrease in discharge gas superheat
08		Excessively high discharge gas temperature at top of compressor chamber
09	Outdoor unit	Activation of protection device for outdoor fan
11	Sensor on indoor unit	Inlet air thermistor
12		Outlet air thermistor
13		Freeze protection thermistor
14		Gas piping thermistor
19	Fan motor	Activation of the protection device for the indoor fan
20	Sensor on outdoor unit	Compressor thermistor
21		High pressure sensor
22		Outdoor air thermistor
23		Discharge gas thermistor
24		Evaporating thermistor
29		Low pressure sensor
31	System	Incorrect capacity setting of outdoor unit and indoor unit
32		Incorrect setting of other indoor unit number
35		Incorrect setting of indoor unit number
36		Incorrect of indoor unit combination
38		Abnormality of picking up circuit for protection in outdoor unit
39	Compressor	Abnormality running current at constant speed compressor
41	Pressure	Overload cooling
42		Overload heating
43	Protection device	Activation of pressure ratio decrease protection device
44		Activation of low pressure decrease protection device
45		Activation of low pressure increase protection device
46		Activation of high pressure increase protection device
47		Activation of high pressure decrease protection device
48		Activation of overcurrent protection device
51	Inverter	Abnormal inverter current sensor
52		Activation of inverter overcurrent protection
53		Activation of transistor module protection
54		Abnormality of inverter fin temperature
56	Outdoor fan	Abnormality of detection for fan motor position
57		Activation of fan controller protection
58		Abnormality of fan controller
b0	System	Incorrect setting of unit capacity
b1		Incorrect setting of unit and refrigerant cycle number
b5		Incorrect setting of indoor unit number for H-LINK type.
EE	Compressor	Compressor protection alarm