

7.1.5 RPI(L/H)-(0.4-6.0)FSRE - Indoor ducted unit

◆ **RPIL-(0.4-1.5)FSRE - Indoor ducted unit**

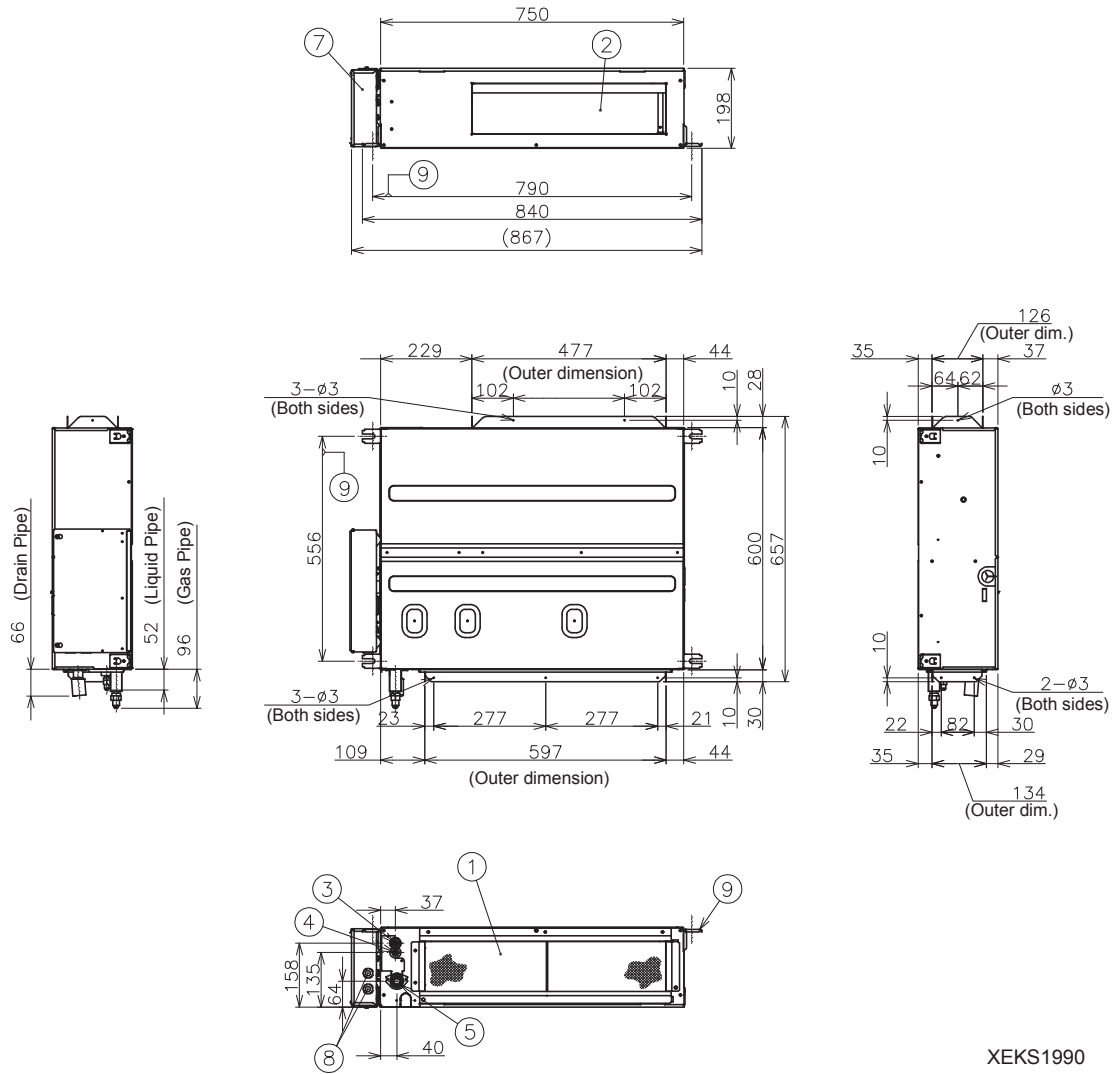

XEKS1990

Number	Description	Remarks
1	Air inlet	
2	Air outlet	
3	Refrigerant connection (gas line)	Flare nut. $\phi 12.7$ (1/2)
4	Refrigerant connection (liquid line)	Flare nut. $\phi 6.35$ (1/4)
5	Condensate drain piping	$\phi 32$ (inner diameter)
7	Electrical box	
8	Wiring connections	
9	Suspension brackets	(4 locations)

NOTE

All measurements are in mm.