

**7.1.10 RPF1-(1.0-2.5)FSN2E - Floor concealed type**

◆ **RPF1-1.0FSN2E - Floor concealed type**

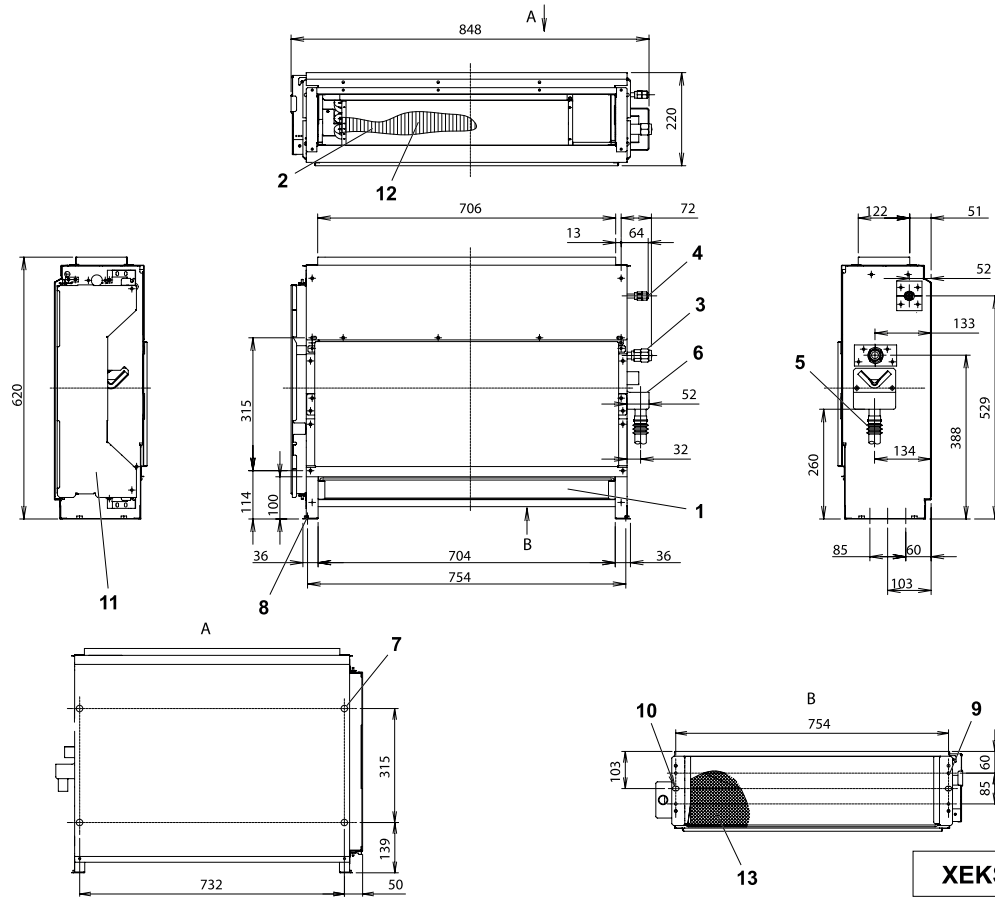

No.	Description	Remarks
1	Air inlet	
2	Air outlet	
3	Refrigerant connection (gas)	Flare nut. $\varnothing 12.7$
4	Refrigerant connection (liquid)	Flare nut. $\varnothing 6.35$
5	Drain connection	
6	Drain pan	
7	Holes to fix the unit to the wall	(4x) $\varnothing 14$ (behind)
8	Adjusting screw	For the installation
9	Holes to fix the unit to the floor	(4x) $\varnothing 7$ , bolts for wood (4x) M5
10	Holes to fix the unit to the floor	(2x) $\varnothing 12.5 \times 18$ , bolts (2x) M8
11	Electrical box	
12	Evaporator	
13	Filter	

All measurements are in mm.



◆ **RPFI-(2.0/2.5)FSN2E - Floor concealed type**

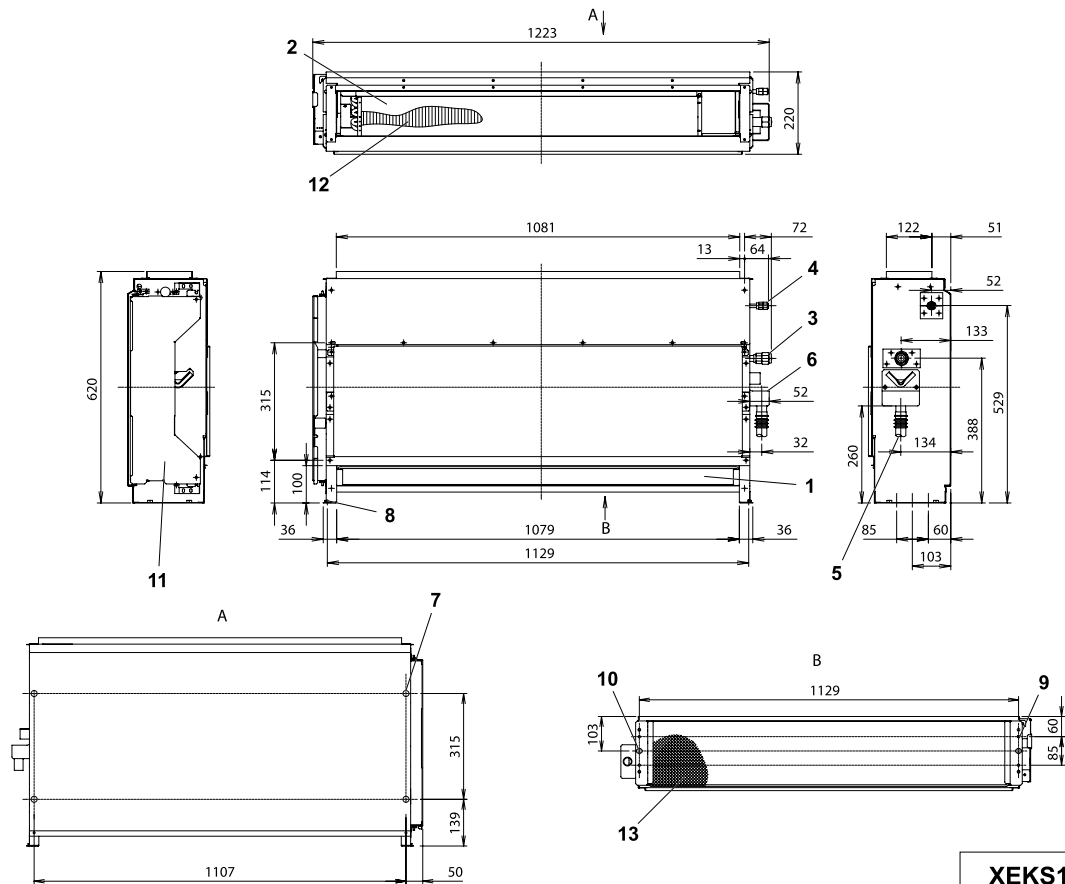

**XEKS1243**



No.	Description	Remarks
1	Air inlet	
2	Air outlet	
3	Refrigerant connection (gas)	Flare nut. $\phi 15.88$
4	Refrigerant connection (liquid)	Flare nut. $\phi 6.35$ RPFI-(2.0), $\phi 9.53$ RPFI-(2.5)
5	Drain connection	
6	Drain pan	
7	Holes to fix the unit to the wall	(4x) $\phi 14$ (behind)
8	Adjusting screw	For the installation
9	Holes to fix the unit to the floor	(4x) $\phi 7$ , bolts for wood (4x) M5
10	Holes to fix the unit to the floor	(2x) $\phi 12.5 \times 18$ , bolts (2x) M8
11	Electrical box	
12	Evaporator	
13	Filter	

All measurements are in mm.