

CONSTRUCTION AND DIMENSIONAL DIAGRAM FOR INDOOR

MODEL RAD-18QPE, RAD-25RPE, RAD-35RPE

Unit: mm

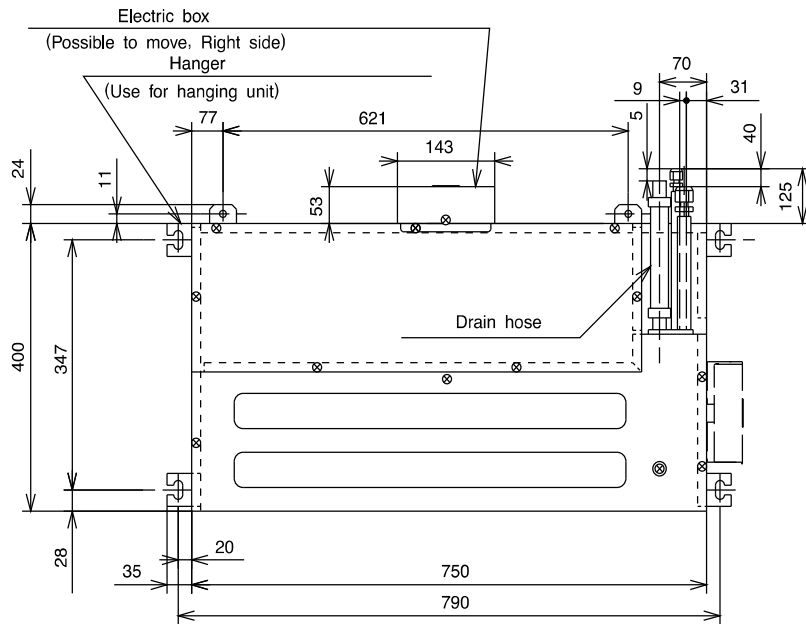

OPTIONAL
Wired Remote Controller
(SPX-RCDA)

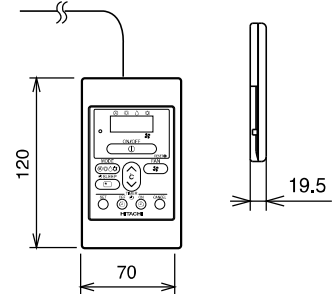

OPTIONAL
Wireless Remote Controller
(SPX-RCKA 1)

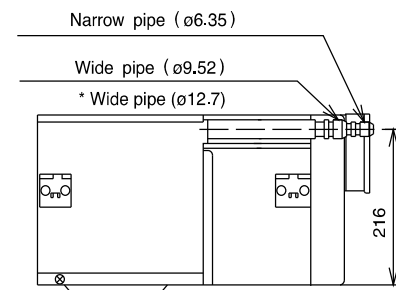
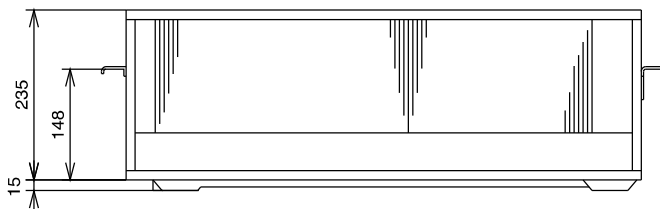
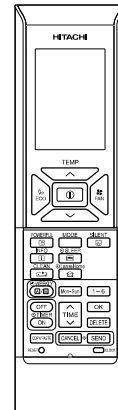

BACK SUCTION

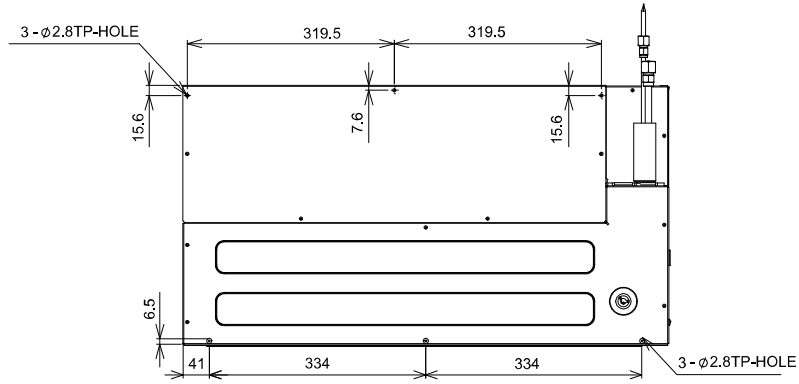
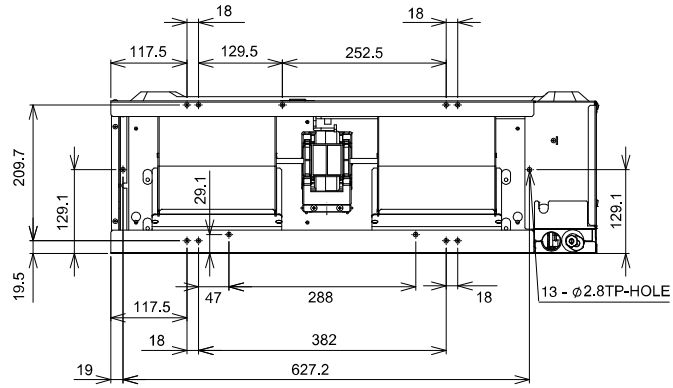

DISCHARGE

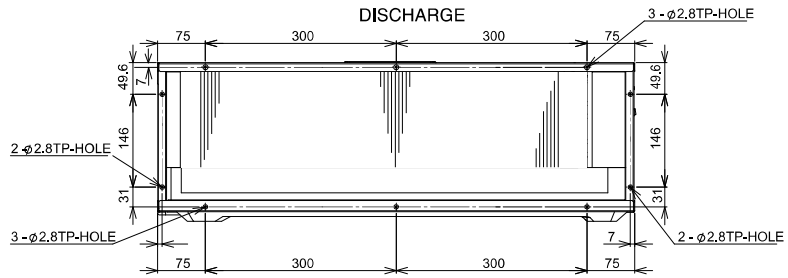

BOTTOM SUCTION

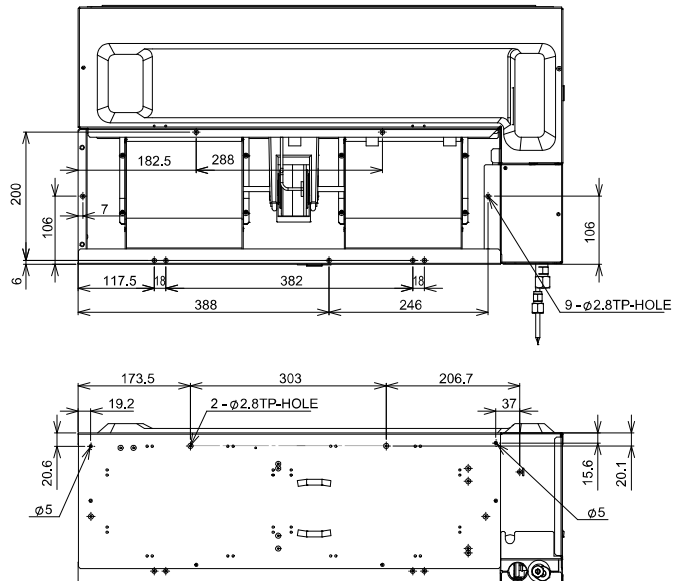

Cautions:

1. Use insulated pipes for both large and small diameters.

CONSTRUCTION AND DIMENSIONAL DIAGRAM

MODEL RAD-50RPE
RAD-60RPE

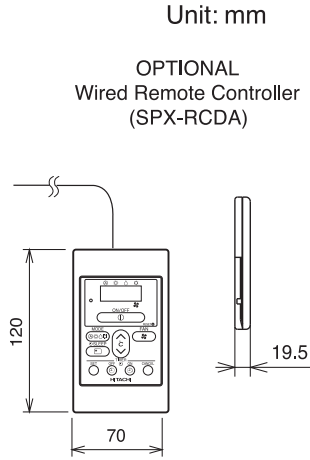
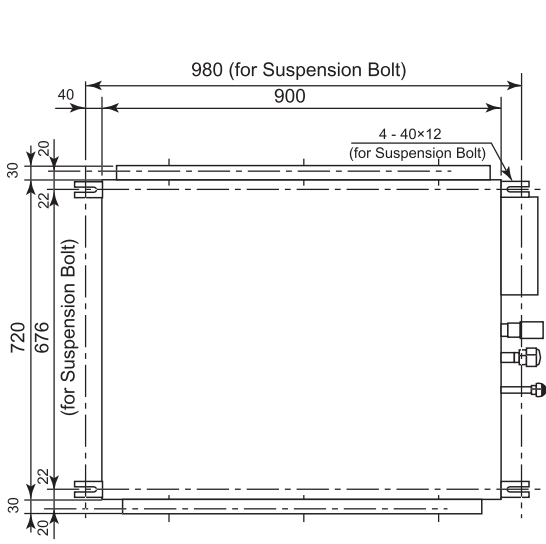

OPTIONAL
Wireless Remote Controller
(SPX-RCKA1)

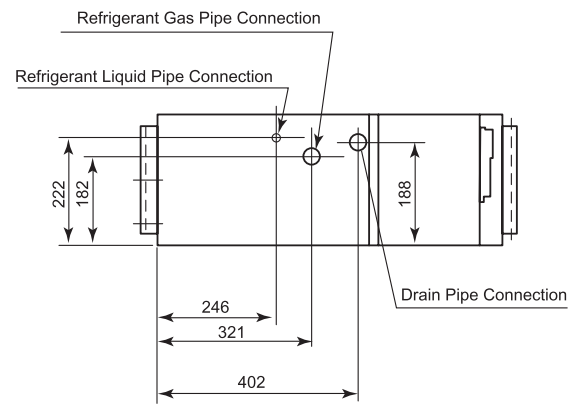
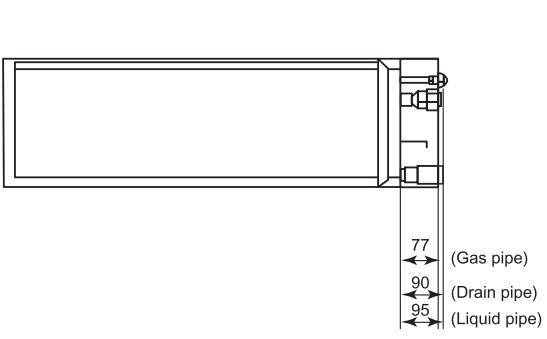
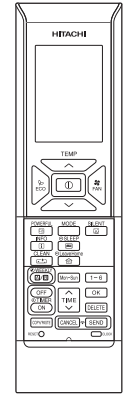

Note:

1. Servicing space of 100mm or more is required on the left and right sides of the indoor unit and also 50mm or more space is required above the unit
2. Insulated pipes should be used for both the narrow and wide dia. pipes.
3. Piping length is within 30m
4. Height different of the piping between the indoor unit and the outdoor unit should be within 10m.
5. Connecting cable 2.5mm dia. x 3 (LN Line), 1.5mm dia. x 4 is used for the connection.

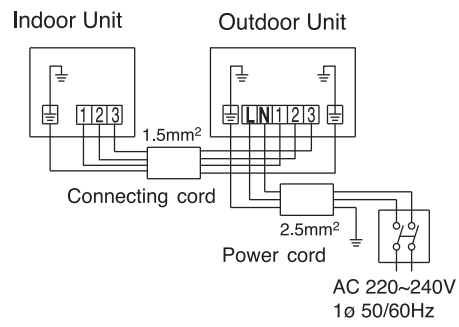

MOUNTING HOLE DIMENSION

MODEL RAD-50RPE
RAD-60RPE

SIDE VIEW

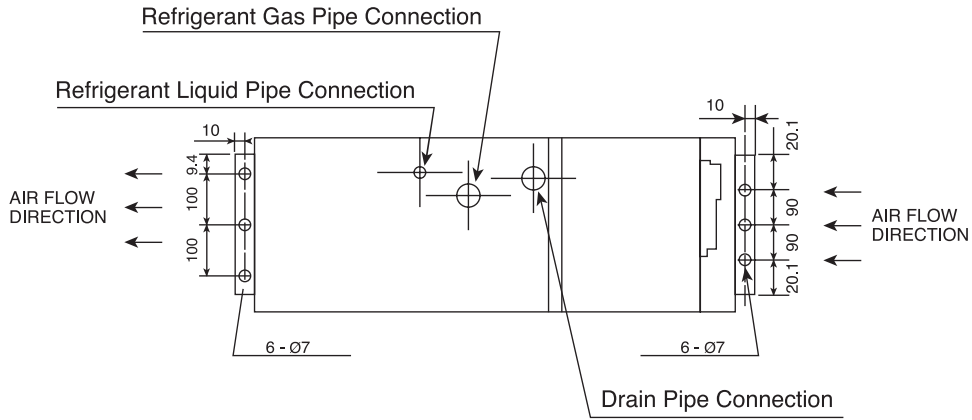

TOP VIEW

