

SERVICE MANUAL

Series PKA Wall Mounted
R410A

Indoor unit

[Model names] [Service Ref.]

PKA-RP35HAL

PKA-RP35HAL

PKA-RP50HAL

PKA-RP50HAL

NOTE:

- This manual describes only service data of the indoor units.
- RoHS compliant products have <G> mark on the spec name plate.

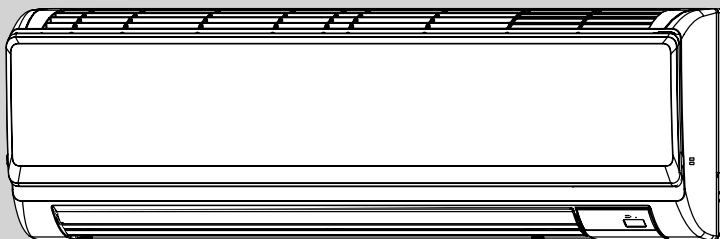

INDOOR UNIT

CONTENTS

| | |
|------------------------------------|----|
| 1. REFERENCE MANUAL..... | 2 |
| 2. SAFETY PRECAUTION..... | 3 |
| 3. PART NAMES AND FUNCTIONS..... | 4 |
| 4. SPECIFICATIONS..... | 6 |
| 5. NOISE CRITERION CURVES..... | 7 |
| 6. OUTLINES AND DIMENSIONS..... | 8 |
| 7. WIRING DIAGRAM..... | 9 |
| 8. REFRIGERANT SYSTEM DIAGRAM..... | 10 |
| 9. TROUBLESHOOTING..... | 11 |
| 10. SPECIAL FUNCTION..... | 26 |
| 11. DISASSEMBLY PROCEDURE..... | 29 |

PARTS CATALOG (OCB453)

OUTDOOR UNIT'S SERVICE MANUAL

| Service Ref. | Service Manual No. |
|--|--------------------|
| PUHZ-RP35/50/60/71VHA4 PUHZ-RP100/125/140VKA PUHZ-RP100/125/140/200/250YKA | OCH451 OCB451 |
| PU(H)-P71/100VHA#2.UK PU(H)-P71/100/125/140YHA#2.UK | OC379 |
| PUHZ-P100/125/140VHA3.UK | OCH415/OCB415 |
| PUHZ-P200/250YHA3 | OCH424/OCB424 |
| PUHZ-HRP71/100VHA2 PUHZ-HRP100/125YHA2 | OCH425/OCB425 |

2-1. ALWAYS OBSERVE FOR SAFETY

Before obtaining access to terminal, all supply circuits must be disconnected.

2-2. CAUTIONS RELATED TO NEW REFRIGERANT

Caution for units utilising refrigerant R410A

Use new refrigerant pipes.

In case of using the existing pipes for R22, be careful with the followings.

- For RP100, 125 and 140, be sure to perform replacement operation before test run.
- Change flare nut to the one provided with this product. Use a newly flared pipe.
- Avoid using thin pipes.

Make sure that the inside and outside of refrigerant piping is clean and it has no contamination such as sulfur hazardous for use, oxides, dirt, shaving particles, etc. In addition, use pipes with specified thickness.

Contamination inside refrigerant piping can cause deterioration of refrigerant oil etc.

Store the piping to be used indoors during installation, and keep both ends of the piping sealed until just before brazing. (Leave elbow joints, etc. in their packaging.)

If dirt, dust or moisture enters into refrigerant cycle, that can cause deterioration of refrigerant oil or malfunction of compressor.

Use ester oil, ether oil or alkylbenzene oil (small amount) as the refrigerant oil applied to flares and flange connections.

If large amount of mineral oil enters, that can cause deterioration of refrigerant oil etc.

Charge refrigerant from liquid phase of gas cylinder.

If the refrigerant is charged from gas phase, composition change may occur in refrigerant and the efficiency will be lowered.

Do not use refrigerant other than R410A.

If other refrigerant (R22 etc.) is used, chlorine in refrigerant can cause deterioration of refrigerant oil etc.

Use a vacuum pump with a reverse flow check valve.

Vacuum pump oil may flow back into refrigerant cycle and that can cause deterioration of refrigerant oil etc.

Use the following tools specifically designed for use with R410A refrigerant.

The following tools are necessary to use R410A refrigerant.

| Tools for R410A | |
|-------------------|---------------------------------------|
| Gauge manifold | Flare tool |
| Charge hose | Size adjustment gauge |
| Gas leak detector | Vacuum pump adaptor |
| Torque wrench | Electronic refrigerant charging scale |

Handle tools with care.

If dirt, dust or moisture enters into refrigerant cycle, that can cause deterioration of refrigerant oil or malfunction of compressor.

Do not use a charging cylinder.

If a charging cylinder is used, the composition of refrigerant will change and the efficiency will be lowered.

Ventilate the room if refrigerant leaks during operation. If refrigerant comes into contact with a flame, poisonous gases will be released.

[1] Cautions for service

- (1) Perform service after recovering the refrigerant left in unit completely.
- (2) Do not release refrigerant in the air.
- (3) After completing service, charge the cycle with specified amount of refrigerant.
- (4) When performing service, install a filter drier simultaneously.
Be sure to use a filter drier for new refrigerant.

[2] Additional refrigerant charge

When charging directly from cylinder

- Check that cylinder for R410A on the market is syphon type.
- Charging should be performed with the cylinder of syphon stood vertically. (Refrigerant is charged from liquid phase.)

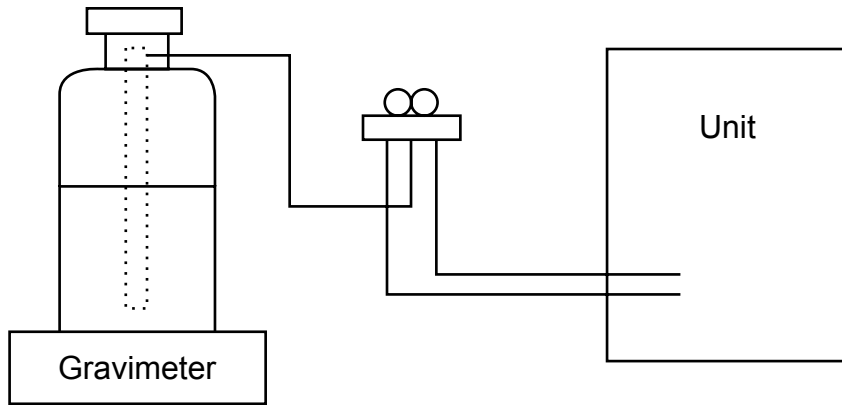

[3] Service tools

Use the below service tools as exclusive tools for R410A refrigerant.

| No. | Tool name | Specifications |
|-----|--------------------------------|---|
| ① | Gauge manifold | · Only for R410A |
| | | · Use the existing fitting specifications. (UNF1/2) |
| | | · Use high-tension side pressure of 5.3MPa-G or over. |
| ② | Charge hose | · Only for R410A |
| | | · Use pressure performance of 5.09MPa-G or over. |
| ③ | Electronic scale | — |
| ④ | Gas leak detector | · Use the detector for R134a, R407C or R410A. |
| ⑤ | Adaptor for reverse flow check | · Attach on vacuum pump. |
| ⑥ | Refrigerant charge base | — |
| ⑦ | Refrigerant cylinder | · Only for R410A · Top of cylinder (Pink) |
| | | · Cylinder with syphon |
| ⑧ | Refrigerant recovery equipment | — |

3 PART NAMES AND FUNCTIONS

• Indoor unit

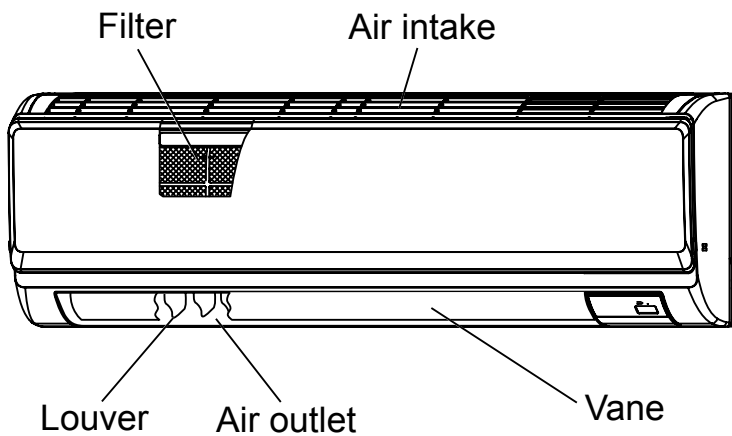

Wireless remote controller

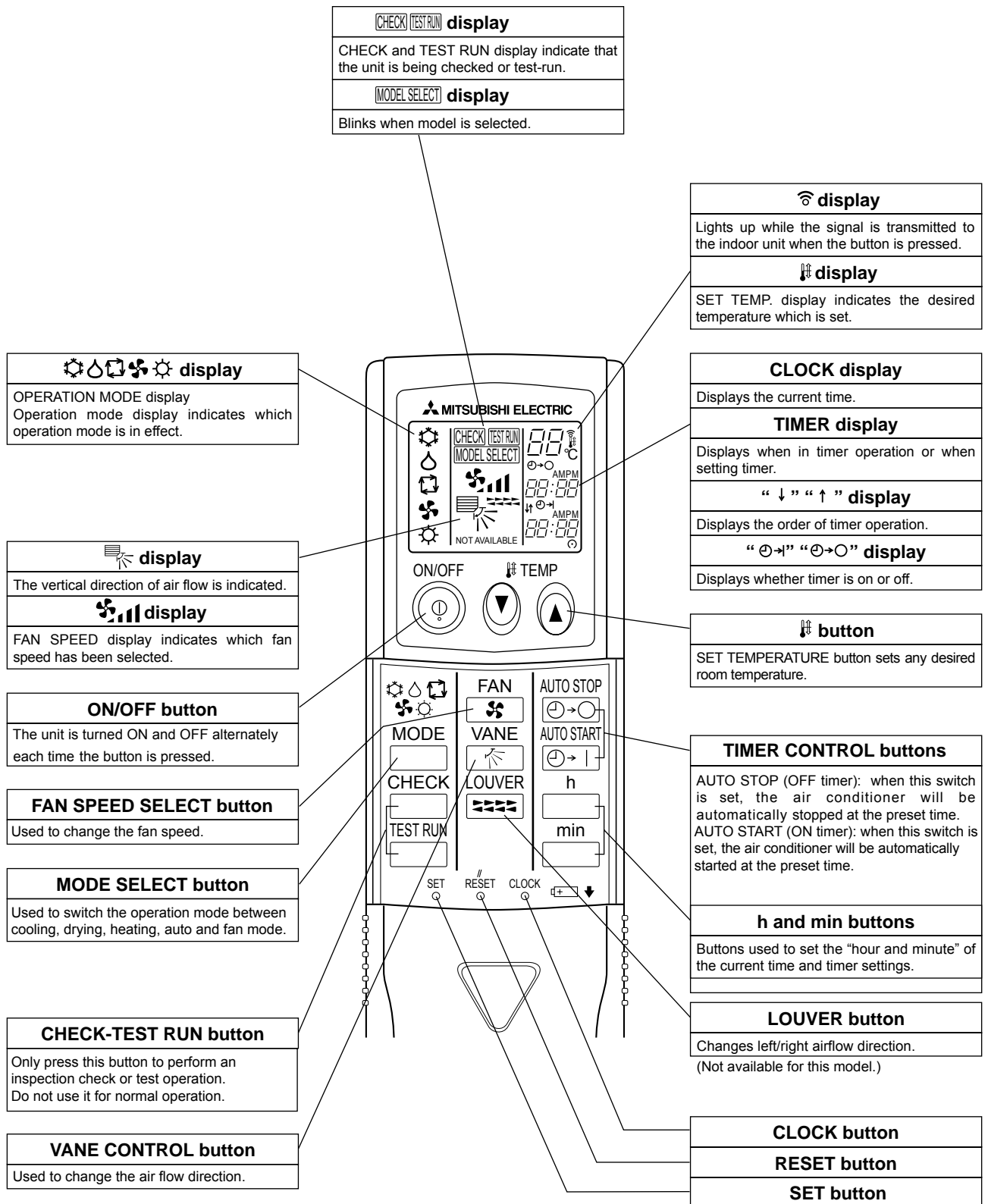

4

SPECIFICATIONS

| Service Ref. | | | PKA-RP35HAL | | |
|--------------|--------------------------------------|---------------------------|---------------------------------------|----------------------------|--|
| INDOOR UNIT | Mode | | Cooling | Heating | |
| | Power supply (phase, cycle, voltage) | | Single phase, 50Hz, 230V | | |
| | Input | kW | 0.04 | 0.03 | |
| | Running current | A | 0.40 | 0.30 | |
| | External finish (Panel) | | Munsell 1.0Y 9.2/0.2 | | |
| | Heat exchanger | | Plate fin coil | | |
| | Fan | Fan (drive) × No. | | Line flow fan (direct) × 1 | |
| | | Fan motor output | kW | 0.030 | |
| | | Airflow (Low-Middle-High) | m ³ /min(CFM) | 9-10.5-12 (320-370-425) | |
| | | External static pressure | Pa(mmAq) | 0 (direct blow) | |
| | Booster heater | | kW | - | |
| | Operation control & Thermostat | | Wireless remote controller & built-in | | |
| | Noise level (Low-Middle-High) | | dB | | |
| | Field drain pipe I.D. | | mm(in.) | | |
| | Dimensions | W | mm(in.) | 898 (35-3/8) | |
| | | D | mm(in.) | 249 (9-13/16) | |
| H | | mm(in.) | 295 (11-5/8) | | |
| Weight | | kg(lbs) | 13 (29) | | |

| Service Ref. | | | PKA-RP50HAL | | |
|--------------|--------------------------------------|---------------------------|---------------------------------------|----------------------------|--|
| INDOOR UNIT | Mode | | Cooling | Heating | |
| | Power supply (phase, cycle, voltage) | | Single phase, 50Hz, 230V | | |
| | Input | kW | 0.04 | 0.03 | |
| | Running current | A | 0.40 | 0.30 | |
| | External finish (Panel) | | Munsell 1.0Y 9.2/0.2 | | |
| | Heat exchanger | | Plate fin coil | | |
| | Fan | Fan (drive) × No. | | Line flow fan (direct) × 1 | |
| | | Fan motor output | kW | 0.030 | |
| | | Airflow (Low-Middle-High) | m ³ /min(CFM) | 9-10.5-12 (320-370-425) | |
| | | External static pressure | Pa(mmAq) | 0 (direct blow) | |
| | Booster heater | | kW | - | |
| | Operation control & Thermostat | | Wireless remote controller & built-in | | |
| | Noise level (Low-Middle-High) | | dB | | |
| | Field drain pipe I.D. | | mm(in.) | | |
| | Dimensions | W | mm(in.) | 898 (35-3/8) | |
| | | D | mm(in.) | 249 (9-13/16) | |
| H | | mm(in.) | 295 (11-5/8) | | |
| Weight | | kg(lbs) | 13 (29) | | |

5

NOISE CRITERION CURVES

5-1. SOUND LEVELS

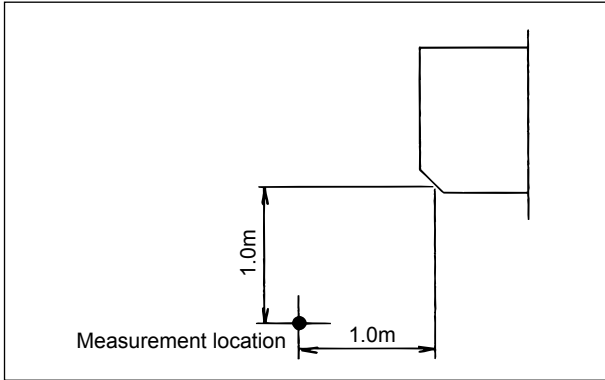

Sound level at anechoic room : Low-Middle-High

| | Sound level dB (A) |
|-----------------|--------------------|
| PKA-RP35, 50HAL | 36 - 40 - 43 |

* Measured in anechoic room.

5-2. NOISE CRITERION CURVES

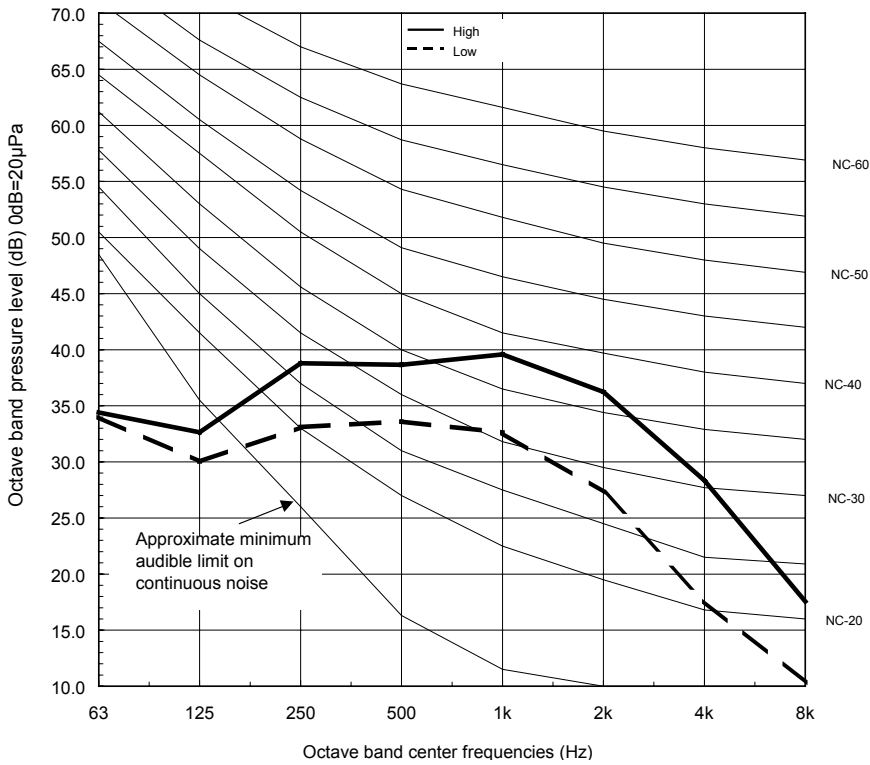

PKA-RP35HAL

PKA-RP50HAL

Unit : mm

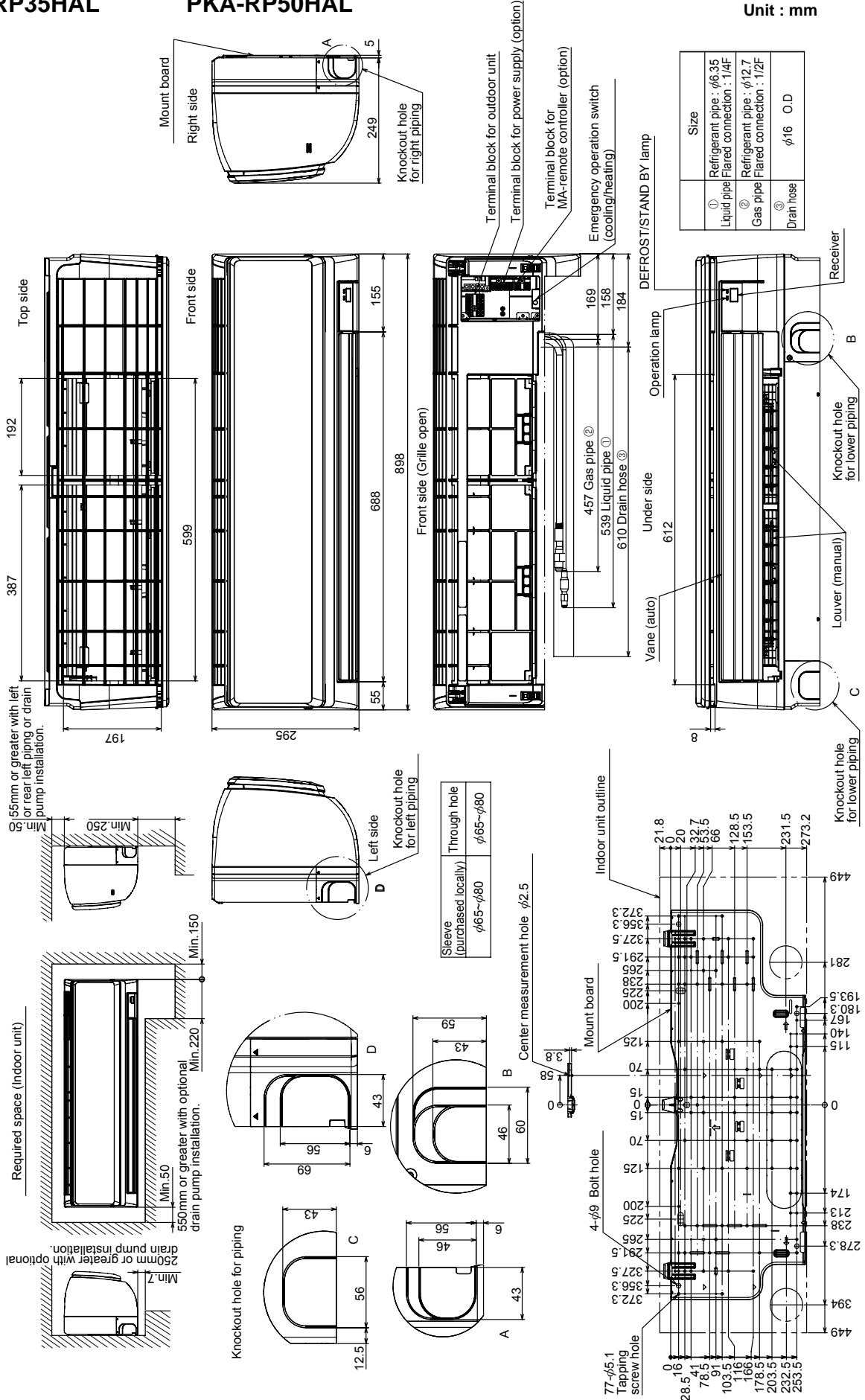

PKA-RP35HAL

PKA-RP50HAL

[Explanation of symbols]

| Symbol | Name | Symbol | Name |
|----------|--|--------|--|
| I.B | Indoor controller board | M | Vane motor |
| CN2L | Connector (LOSSNAY) | MS | Fan motor |
| CN32 | Connector (Remote switch) | S.W | Switch board |
| CN41 | Connector (HA terminal-A) | SWE2 | Emergency operation |
| CN51 | Connector (Centrally control) | TB2 | Terminal block(Indoor unit Power (option)) |
| CN90 | Connector (Remote operation adapter) | TB4 | Terminal block (Indoor/outdoor connecting line) |
| DSA | Surge absorber | TB5 | Terminal block (Remote controller transmission line(option)) |
| FUSE | FUSE(T3.15AL250V) | TH1 | Room temp. Thermistor (0°C/15KΩ, 25°C/5.4KΩ Detect) |
| LED1 | Power supply (I.B) | TH2 | Pipe temp. Thermistor/liquid (0°C/15KΩ, 25°C/5.4KΩ Detect) |
| LED2 | Power supply (R.B) | TH5 | Cond./eva. temp. Thermistor (0°C/15KΩ, 25°C/5.4KΩ Detect) |
| LED3 | Transmission (Indoor-outdoor) | W.B | Pcb for wireless remote controller |
| SW1 | Switch (Model selection) *See table 1 | LED1 | LED (Operation indication : Green) |
| SW2 | Switch (Capacity code) *See table 2 | LED2 | LED (Preparation for heating: Orange) |
| SWE | Connector (Emergency operation) | REC1 | Receiving unit |
| X1 | Relay (Drain pump (option)) | DCL | REACTOR |
| ZNR01,02 | Varistor | DP | DRAIN PUMP (OPTION) |
| CNP | Drain pump (option) power supply (Drain pump (option)) | FS | DRAIN FLOAT SWITCH (OPTION) |
| CN4F | Drain float switch (Drain pump (option)) | | |
| R.B | Wired remote controller(option) | | |
| TB6 | Terminal block (Remote controller transmission line) | | |

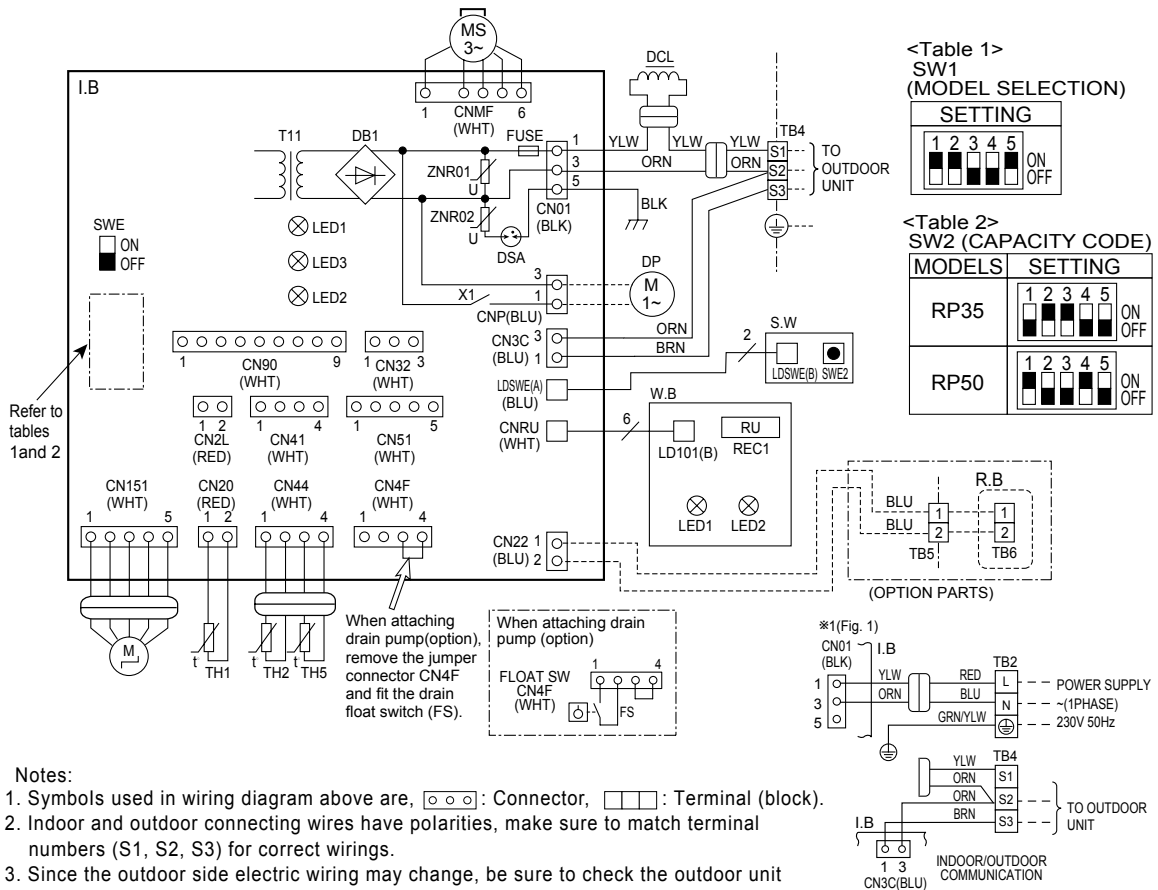

Notes:

1. Symbols used in wiring diagram above are, [] : Connector, [] : Terminal (block).
 2. Indoor and outdoor connecting wires have polarities, make sure to match terminal numbers (S1, S2, S3) for correct wirings.
 3. Since the outdoor side electric wiring may change, be sure to check the outdoor unit electric wiring diagram for servicing.
 4. This diagram shows the wiring of indoor and outdoor connecting wires. (specification of 230V), adopting superimposed system for power and signal.
- *1: When work to supply power separately for indoor and outdoor units apply, refer to Fig 1.
*2: For power supply system of this unit, refer to the caution label located near this diagram.

8

REFRIGERANT SYSTEM DIAGRAM

PKA-RP35HAL

PKA-RP50HAL

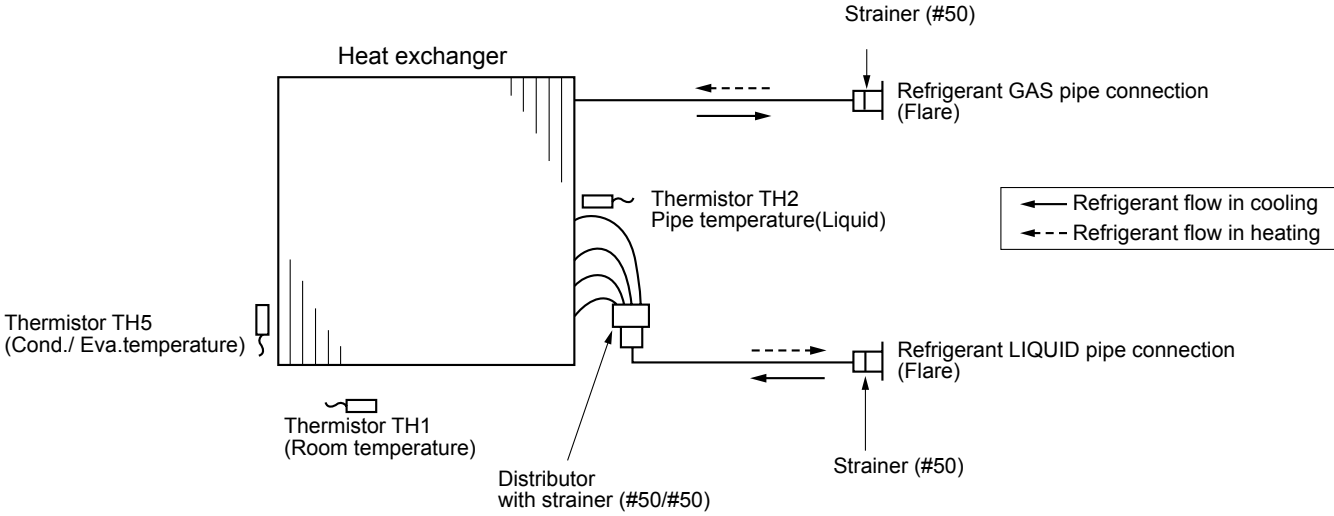

9-1. TROUBLESHOOTING

<Error code display by self-diagnosis and actions to be taken for service (summary)>

Present and past error codes are logged and displayed on the wired remote controller or controller board of outdoor unit. Actions to be taken for service and the trouble recurrence at field are summarized in the table below. Check the contents below before investigating details.

| Unit conditions at service | Error code | Actions to be taken for service (summary) |
|---------------------------------|---------------|--|
| The trouble is reoccurring. | Displayed | Judge what is wrong and take a corrective action according to "9-3. Self-diagnosis action table". |
| | Not displayed | Conduct troubleshooting and ascertain the cause of the trouble according to "9-4. Troubleshooting by inferior phenomena". |
| The trouble is not reoccurring. | Logged | <ul style="list-style-type: none"> ① Consider the temporary defects such as the work of protection devices in the refrigerant circuit including compressor, poor connection of wiring, noise and etc. Re-check the symptom, and check the installation environment, refrigerant amount, weather when the trouble occurred, matters related to wiring and etc. ② Reset error code logs and restart the unit after finishing service. ③ There is no abnormality in electrical component, controller board, remote controller and etc. |
| | Not logged | <ul style="list-style-type: none"> ① Re-check the abnormal symptom. ② Conduct trouble shooting and ascertain the cause of the trouble according to "9-4. Troubleshooting by inferior phenomena". ③ Continue to operate unit for the time being if the cause is not ascertained. ④ There is no abnormality concerning of parts such as electrical component, controller board, remote controller and etc. |

9-2. MALFUNCTION-DIAGNOSIS METHOD BY REMOTE CONTROLLER

<In case of trouble during operation>

When a malfunction occurs to air conditioner, both indoor unit and outdoor unit will stop and operation lamp blinks to inform unusual stop.

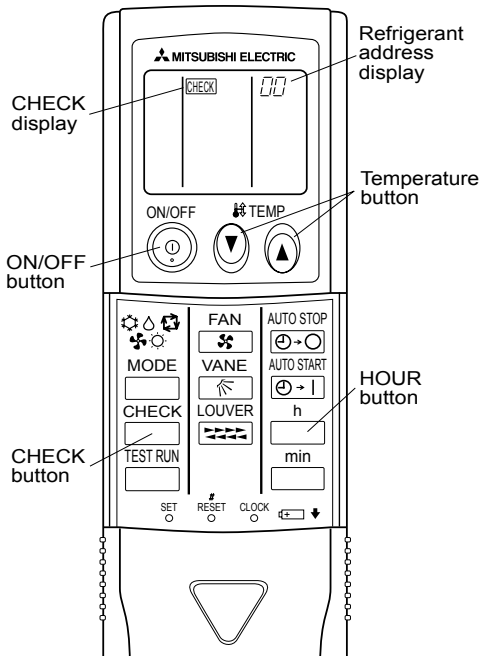

<Malfunction-diagnosis method at maintenance service>

[Procedure]



1. Press the CHECK button twice.

- "CHECK" lights, and refrigerant address "00" flashes.
- Check that the remote controller's display has stopped before continuing.

2. Press the temperature   buttons.

- Select the refrigerant address of the indoor unit for the self-diagnosis.
- Note: Set refrigerant address using the outdoor unit's DIP switch (SW1). (For more information, see the outdoor unit installation manual.)

3. Point the remote controller at the sensor on the indoor unit and press the HOUR button.

- If an air conditioner error occurs, the indoor unit's sensor emits an intermittent buzzer sound, the operation light flashes, and the error code is output. (It takes 3 seconds at most for error code to appear.)

4. Point the remote controller at the sensor on the indoor unit and press the ON/OFF button.

- The check mode is cancelled.

To be continued to the next page.

• Refer to the following tables for details on the check codes.

[Output pattern A]

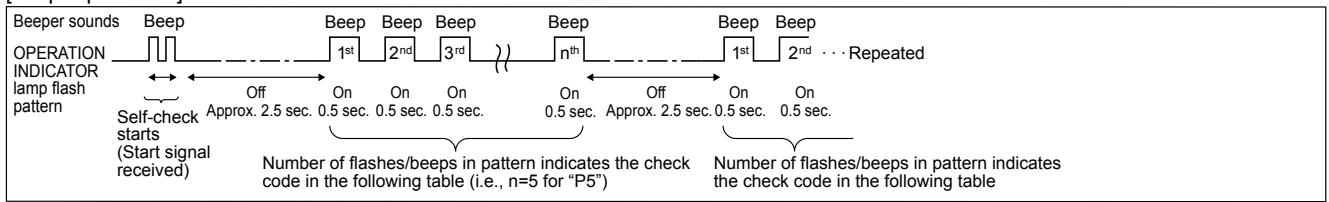

[Output pattern B]

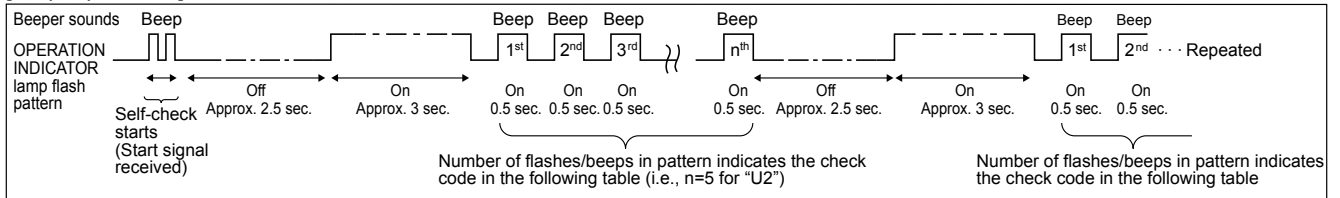

[Output pattern A] Errors detected by indoor unit

| Wireless remote controller Beeper sounds/OPERATION INDICATOR lamp flashes (Number of times) | Wired remote controller Check code | Symptom | Remark |
|--|---------------------------------------|--|--------|
| 1 | P1 | Intake sensor error | — |
| 2 | P2 | Pipe (TH2) sensor error | |
| | P9 | Pipe (TH5) sensor error | |
| 3 | E6, E7 | Indoor/outdoor unit communication error | |
| 4 | P4 | Drain sensor error/Float switch connector (CN4F) open | |
| 5 | P5 | Drain pump error | |
| | PA | Forced compressor stop(due to water leakage abnormality) | |
| 6 | P6 | Freezing/Overheating protection operation | |
| 7 | EE | Communication error between indoor and outdoor units | |
| 8 | P8 | Pipe temperature error | |
| 9 | E4, E5 | Remote controller signal receiving error | |
| 10 | — | — | |
| 11 | — | — | |
| 12 | Fb | Indoor unit control system error (memory error, etc.) | |
| — | E0, E3 | Remote controller transmission error | |
| — | E1, E2 | Remote controller control board error | |

[Output pattern B] Errors detected by unit other than indoor unit (outdoor unit, etc.)

| Wireless remote controller Beeper sounds/OPERATION INDICATOR lamp flashes (Number of times) | Wired remote controller Check code | Symptom | Remark |
|--|---------------------------------------|---|--|
| 1 | E9 | Indoor/outdoor unit communication error (Transmitting error) (Outdoor unit) | For details, check the LED display of the outdoor controller board. As for outdoor unit, refer to outdoor unit's service manual. |
| 2 | UP | Compressor overcurrent interruption | |
| 3 | U3, U4 | Open/short of outdoor unit thermistors | |
| 4 | UF | Compressor overcurrent interruption (When compressor locked) | |
| 5 | U2 | Abnormal high discharging temperature/49C worked/ insufficient refrigerant | |
| 6 | U1, Ud | Abnormal high pressure (63H worked)/Overheating protection operation | |
| 7 | U5 | Abnormal temperature of heat sink | |
| 8 | U8 | Outdoor unit fan protection stop | |
| 9 | U6 | Compressor overcurrent interruption/Abnormal of power module | |
| 10 | U7 | Abnormality of super heat due to low discharge temperature | |
| 11 | U9, UH | Abnormality such as overvoltage or voltage shortage and abnormal synchronous signal to main circuit/Current sensor error | |
| 12 | — | — | |
| 13 | — | — | |
| 14 | Others | Other errors (Refer to the technical manual for the outdoor unit.) | |

*1 If the beeper does not sound again after the initial 2 beeps to confirm the self-check start signal was received and the OPERATION INDICATOR lamp does not come on, there are no error records.

*2 If the beeper sounds 3 times continuously "beep, beep, beep (0.4 + 0.4 + 0.4 sec.)" after the initial 2 beeps to confirm the self-check start signal was received, the specified refrigerant address is incorrect.

- On wireless remote controller
The continuous buzzer sounds from receiving section of indoor unit.
Blink of operation lamp
- On wired remote controller
Check code displayed in the LCD.

- On wireless remote controller
The continuous buzzer sounds from receiving section of indoor unit.
Blink of operation lamp
- On wired remote controller
Check code displayed in the LCD.

• If the unit cannot be operated properly after test run, refer to the following table to find the cause.

| Symptom | | Cause |
|--|--|--|
| Wired remote controller | LED 1, 2 (PCB in outdoor unit) | |
| PLEASE WAIT | For about 2 minutes after power-on | After LED 1, 2 are lighted, LED 2 is turned off, then only LED 1 is lighted. (Correct operation) |
| PLEASE WAIT → Error code | Subsequent to about 2 minutes after power-on | Only LED 1 is lighted. → LED 1, 2 blink. |
| Display messages do not appear even when operation switch is turned ON (operation lamp does not light up). | | Only LED 1 is lighted. → LED 1 blinks twice, LED 2 blinks once. |

On the wireless remote controller with condition above, following phenomena take place.

- No signals from the remote controller can be received.
- Operation lamp is blinking.
- The buzzer makes a short ping sound.

Note:

Operation is not possible for about 30 seconds after cancellation of function selection. (Correct operation)

For description of each LED (LED1, 2, 3) provided on the indoor controller, refer to the following table.

| | |
|---|--|
| LED1 (power for microcomputer) | Indicates whether control power is supplied. Make sure that this LED is always lit. |
| LED2 (power for remote controller) | Indicates whether power is supplied to the remote controller. This LED lights only in the case of the indoor unit which is connected to the outdoor unit refrigerant addresses "0". |
| LED3 (communication between indoor and outdoor units) | Indicates state of communication between the indoor and outdoor units. Make sure that this LED is always blinking. |

Note: Refer to the manual of outdoor unit for the details of display such as F, U, and other E.

9-3. SELF-DIAGNOSIS ACTION TABLE

| Error Code | Abnormal point and detection method | Cause | Countermeasure |
|------------|---|--|--|
| P1 | <p>Room temperature thermistor (TH1)</p> <p>① The unit is in 3-minute resume prevention mode if short/open of thermistor is detected. Abnormal if the unit does not reset normally after 3 minutes. (The unit returns to normal operation, if it has been reset normally.)</p> <p>② Constantly detected during cooling, drying, and heating operation. Short: -90°C or more Open: -40°C or less</p> | <p>① Defective thermistor characteristics</p> <p>② Contact failure of connector (CN20) on the indoor controller board (Insert failure)</p> <p>③ Breaking of wire or contact failure of thermistor wiring</p> <p>④ Defective indoor controller board</p> | <p>①-③ Check resistance value of thermistor. 0°C15.0kΩ 10°C9.6kΩ 20°C6.3kΩ 30°C4.3kΩ 40°C3.0kΩ</p> <p>If you put force on (draw or bend) the lead wire with measuring resistance value of thermistor, breaking of wire or contact failure can be detected.</p> <p>② Check contact failure of connector (CN20) on the indoor controller board. Refer to 9-7. Turn the power on again and check restart after inserting connector again.</p> <p>④ Check room temperature display on remote controller. Replace indoor controller board if there is abnormal difference with actual room temperature.</p> <p>Turn the power off, and on again to operate after check.</p> |
| P2 | <p>Pipe temperature thermistor/Liquid (TH2)</p> <p>① The unit is in 3-minute resume prevention mode if short/open of thermistor is detected. Abnormal if the unit does not reset normally after 3 minutes. (The unit returns to normal operation, if it has been reset normally.)</p> <p>② Constantly detected during cooling, drying, and heating (except defrosting) operation Short: 90°C or more Open: -40°C or less</p> | <p>① Defective thermistor characteristics</p> <p>② Contact failure of connector (CN44) on the indoor controller board (Insert failure)</p> <p>③ Breaking of wire or contact failure of thermistor wiring</p> <p>④ Defective refrigerant circuit is causing thermistor temperature of 90°C or more or -40°C or less.</p> <p>⑤ Defective indoor controller board</p> | <p>①-③ Check resistance value of thermistor. For characteristics, refer to (P1) above.</p> <p>② Check contact failure of connector (CN44) on the indoor controller board. Refer to 9-7. Turn the power on and check restart after inserting connector again.</p> <p>④ Check pipe <liquid> temperature with remote controller in test run mode. If pipe <liquid> temperature is extremely low (in cooling mode) or high (in heating mode), refrigerant circuit may have defective.</p> <p>⑤ Check pipe <liquid> temperature with remote controller in test run mode. If there is extremely difference with actual pipe <liquid> temperature, replace indoor controller board.</p> <p>Turn the power off, and on again to operate after check.</p> |
| P4 | <p>Contact failure of drain float switch (CN4F)</p> <ul style="list-style-type: none"> Extract when the connector of drain float switch is disconnected. (③ and ④ of connector CN4F is not short-circuited.) Constantly detected during operation | <p>① Contact failure of connector (Insert failure)</p> <p>② Defective indoor controller board</p> | <p>① Check contact failure of float switch connector. Turn the power on again and check after inserting connector again.</p> <p>② Operate with connector (CN4F) short-circuited. Replace indoor controller board if abnormality reappears.</p> |
| P5 | <p>Drain over flow protection operation</p> <p>① Suspensive abnormality, if drain float switch is detected to be underwater for 1 minute and 30 seconds continuously with drain pump on. Compressor and indoor fan will be turned off.</p> <p>② Drain pump is abnormal if the condition above is detected during suspensive abnormality.</p> <p>③ Constantly detected during drain pump operation</p> | <p>① Malfunction of drain pump</p> <p>② Defective drain Clogged drain pump Clogged drain pipe</p> <p>③ Defective drain float switch Catch of drain float switch or malfunction of moving parts cause drain float switch to be detected under water (Switch On)</p> <p>④ Defective indoor-controller board</p> | <p>① Check if drain-up machine works.</p> <p>② Check drain function.</p> <p>③ Remove drain float switch connector CN4F and check if it is short (Switch On) with the moving part of float switch UP, or OPEN with the moving part of float switch down. Replace float switch if it is short with the moving part of float switch down.</p> <p>④ Replace indoor controller board if it is short-circuited between ③-④ of the drain float switch connector CN4F and abnormality reappears.</p> <p>It is not abnormal if there is no problem about the above-mentioned Turn the power off, and on again to operate after check.</p> |



| Error Code | Abnormal point and detection method | Cause | Countermeasure |
|------------|---|---|---|
| P6 | <p>Freezing/overheating protection is working</p> <p>① Freezing protection (Cooling mode) The unit is in 6-minute resume prevention mode if pipe <liquid or condenser/evaporator> temperature stays under -15°C for 3 minutes, 3 minutes after the compressor started. Abnormal if it stays under -15°C for 3 minutes again within 16 minutes after 6-minute resume prevention mode.</p> <p>② Overheating protection (Heating mode) The units is in 6 minute resume prevention mode if pipe <liquid or condenser/evaporator> temperature is detected as over 70°C after the compressor started. Abnormal if the temperature of over 70°C is detected again within 30 minutes after 6 minute resume prevention mode.</p> | <p>(Cooling or drying mode)</p> <p>① Clogged filter (reduced airflow) ② Short cycle of air path ③ Low-load (low temperature) operation out of the tolerance range ④ Defective indoor fan motor • Fan motor is defective. • Indoor controller board is defective.</p> <p>⑤ Defective outdoor fan control ⑥ Overcharge of refrigerant ⑦ Defective refrigerant circuit (clogs)</p> <p>(Heating mode)</p> <p>① Clogged filter (reduced airflow) ② Short cycle of air path ③ Over-load (high temperature) operation out of the tolerance range ④ Defective indoor fan motor • Fan motor is defective. • Indoor controller board is defective. ⑤ Defective outdoor fan control ⑥ Overcharge of refrigerant ⑦ Defective refrigerant circuit (clogs) ⑧ Bypass circuit of outdoor unit is defective.</p> | <p>(Cooling or drying mode)</p> <p>① Check clogs of the filter. ② Remove shields.</p> <p>④ Refer to 9-6.</p> <p>⑤ Check outdoor fan motor. ⑥⑦ Check operating condition of refrigerant circuit.</p> <p>(Heating mode)</p> <p>① Check clogs of the filter. ② Remove shields.</p> <p>④ Refer to 9-6.</p> <p>⑤ Check outdoor fan motor. ⑥~⑧ Check operating condition of refrigerant circuit.</p> |
| P8 | <p>Pipe temperature <Cooling mode> Detected as abnormal when the pipe temperature is not in the cooling range 3 minutes after compressor start and 6 minutes after the liquid or condenser/evaporator pipe is out of cooling range. Note 1) It takes at least 9 minutes to detect. Note 2) Abnormality P8 is not detected in drying mode. Cooling range : -3 °C ≧ (TH-TH1) TH: Lower temperature between: liquid pipe temperature (TH2) and condenser/evaporator temperature (TH5) TH1: Intake temperature</p> <p><Heating mode> When 10 seconds have passed after the compressor starts operation and the hot adjustment mode has finished, the unit is detected as abnormal when condenser/evaporator pipe temperature is not in heating range within 20 minutes.</p> <p>Note 3) It takes at least 27 minutes to detect abnormality. Note 4) It excludes the period of defrosting. (Detection restarts when defrosting mode is over.) Heating range : 3 °C ≦ (TH5-TH1)</p> | <p>① Slight temperature difference between indoor room temperature and pipe <liquid or condenser/evaporator> temperature thermistor • Shortage of refrigerant • Disconnected holder of pipe <liquid or condenser/evaporator> thermistor • Defective refrigerant circuit</p> <p>② Converse connection of extension pipe (on plural units connection)</p> <p>③ Converse wiring of indoor/outdoor unit connecting wire (on plural units connection)</p> <p>④ Defective detection of indoor room temperature and pipe <condenser/evaporator> temperature thermistor</p> <p>⑤ Stop valve is not opened completely.</p> | <p>①~④ Check pipe <liquid or condenser/evaporator> temperature with room temperature display on remote controller and outdoor controller circuit board. Pipe <liquid or condenser/evaporator> temperature display is indicated by setting SW2 of outdoor controller circuit board as follows.</p> <p>(Conduct temperature check with outdoor controller circuit board after connecting 'A-Control Service Tool(PAC-SK52ST)')</p> <p>②③ Check converse connection of extension pipe or converse wiring of indoor/outdoor unit connecting wire.</p> |



| Error Code | Abnormal point and detection method | Cause | Countermeasure |
|------------|--|---|---|
| P9 | <p>Pipe temperature thermistor/ Condenser-Evaporator (TH5)</p> <p>① The unit is in 3-minute resume protection mode if short/open of thermistor is detected. Abnormal if the unit does not get back to normal within 3 minutes. (The unit returns to normal operation, if it has been reset normally.)</p> <p>② Constantly detected during cooling, drying, and heating operation (except defrosting) Short: 90°C or more Open: -40°C or less</p> | <p>① Defective thermistor characteristics</p> <p>② Contact failure of connector (CN44) on the indoor controller board (Insert failure)</p> <p>③ Breaking of wire or contact failure of thermistor wiring</p> <p>④ Temperature of thermistor is 90°C or more or -40°C or less caused by defective refrigerant circuit.</p> <p>⑤ Defective indoor controller board</p> | <p>①-③ Check resistance value of thermistor. For characteristics, refer to (P1) above.</p> <p>② Check contact failure of connector (CN44) on the indoor controller board. Refer to 9-7.</p> <p>Turn the power on and check restart after inserting connector again.</p> <p>④ Operate in test run mode and check pipe <condenser/evaporator> temperature with outdoor controller circuit board. If pipe <condenser/evaporator> temperature is extremely low (in cooling mode) or high (in heating mode), refrigerant circuit may have defect.</p> <p>⑤ Operate in test run mode and check pipe <condenser/evaporator> temperature with outdoor control circuit board. If there is extreme difference with actual pipe <condenser/evaporator> temperature, replace indoor controller board. There is no abnormality if none of above comes within the unit.</p> <p>Turn the power off and on again to operate.</p> <p>(In case of checking pipe temperature with outdoor controller circuit board, be sure to connect A-control service tool (PAC-SK52ST).)</p> |
| E0 or E4 | <p>Remote controller transmission error(E0)/signal receiving error(E4)</p> <p>① Abnormal if main or sub remote controller cannot receive any transmission normally from indoor unit of refrigerant address "0" for 3 minutes. (Error code : E0)</p> <p>② Abnormal if sub remote controller could not receive any signal for 2 minutes. (Error code: E0)</p> <p>① Abnormal if indoor controller board can not receive any data normally from remote controller board or from other indoor controller board for 3 minutes. (Error code: E4)</p> <p>② Indoor controller board cannot receive any signal from remote controller for 2 minutes. (Error code: E4)</p> | <p>① Contact failure at transmission wire of remote controller</p> <p>② All remote controllers are set as "sub" remote controller. In this case, E0 is displayed on remote controller, and E4 is displayed at LED (LED1, LED2) on the outdoor controller circuit board.</p> <p>③ Miswiring of remote controller</p> <p>④ Defective transmitting receiving circuit of remote controller</p> <p>⑤ Defective transmitting receiving circuit of indoor controller board of refrigerant addresses "0".</p> <p>⑥ Noise has entered into the transmission wire of remote controller.</p> | <p>① Check disconnection or looseness of indoor unit or transmission wire of remote controller.</p> <p>② Set one of the remote controllers "main" if there is no problem with the action above.</p> <p>③ Check wiring of remote controller.</p> <ul style="list-style-type: none"> • Total wiring length: max. 500m (Do not use cable x 3 or more.) • The number of connecting indoor units: max. 16 units • The number of connecting remote controller: max. 2 units <p>When it is not the above-mentioned problem of ①-③</p> <p>①-③ Diagnose remote controllers.</p> <p>a) When "RC OK" is displayed, Remote controllers have no problem. Turn the power off, and on again to check. If abnormality generates again, replace indoor controller board.</p> <p>b) When "RC NG" is displayed, Replace remote controller.</p> <p>c) When "RC E3" or "ERC 00-66" is displayed, noise may be causing abnormality.</p> <p>* If the unit is not normal after replacing indoor controller board in group control, indoor controller board of address "0" may be abnormal.</p> |
| E3 or E5 | <p>Remote controller transmission error(E3)/signal receiving error(E5)</p> <p>① Abnormal if remote controller could not find blank of transmission path for 6 seconds and could not transmit. (Error code: E3)</p> <p>② Remote controller receives transmitted data at the same time and compares the received and transmitted data. Abnormal if these data are judged to be different 30 continuous times. (Error code: E3)</p> <p>① Abnormal if indoor controller board could not find blank of transmission path. (Error code: E5)</p> <p>② Indoor controller board receives transmitted data at the same time and compares the received and transmitted data. Abnormal if these data are judged to be different 30 continuous times. (Error code: E5)</p> | <p>① 2 remote controllers are set as "main." (In case of 2 remote controllers)</p> <p>② Remote controller is connected with 2 indoor units or more.</p> <p>③ Repetition of refrigerant address</p> <p>④ Defective transmitting receiving circuit of remote controller</p> <p>⑤ Defective transmitting receiving circuit of indoor controller board</p> <p>⑥ Noise has entered into transmission wire of remote controller.</p> | <p>① Set a remote controller to main, and the other to sub.</p> <p>② Remote controller is connected with only one indoor unit.</p> <p>③ The address changes to a separate setting.</p> <p>④-⑥ Diagnose remote controller.</p> <p>a) When "RC OK" is displayed, remote controllers have no problem. Turn the power off, and on again to check. When becoming abnormal again, replace indoor controller board.</p> <p>b) When "RC NG" is displayed, replace remote controller.</p> <p>c) When "RC E3" or "ERC 00-66" is displayed, noise may be causing abnormality.</p> |



| Error Code | Abnormal point and detection method | Cause | Countermeasure |
|------------|---|---|---|
| E6 | <p>Indoor/outdoor unit communication error (Signal receiving error)</p> <p>① Abnormal if indoor controller board cannot receive any signal normally for 6 minutes after turning the power on.</p> <p>② Abnormal if indoor controller board cannot receive any signal normally for 3 minutes.</p> <p>③ Consider the unit abnormal under the following condition: When 2 or more indoor units are connected to an outdoor unit, indoor controller board cannot receive a signal for 3 minutes from outdoor controller circuit board, a signal which allows outdoor controller circuit board to transmit signals.</p> | <p>① Contact failure, short circuit or, miswiring (converse wiring) of indoor/outdoor unit connecting wire</p> <p>② Defective transmitting receiving circuit of indoor controller board</p> <p>③ Defective transmitting receiving circuit of indoor controller board</p> <p>④ Noise has entered into indoor/outdoor unit connecting wire.</p> | <p>* Check LED display on the outdoor control circuit board. (Connect A-control service tool, PAC-SK52ST.) Refer to outdoor unit service manual.</p> <p>① Check disconnection or looseness of indoor/outdoor unit connecting wire of indoor unit or outdoor unit. Check all the units in case of twin triple indoor unit system.</p> <p>②-④ Turn the power off, and on again to check. If abnormality generates again, replace indoor controller board or outdoor controller circuit board.</p> <p>* Other indoor controller board may have defect in case of twin triple indoor unit system.</p> |
| E7 | <p>Indoor/outdoor unit communication error (Transmitting error)</p> <p>Abnormal if "1" receiving is detected 30 times continuously though indoor controller board has transmitted "0".</p> | <p>① Defective transmitting receiving circuit of indoor controller board</p> <p>② Noise has entered into power supply.</p> <p>③ Noise has entered into outdoor control wire.</p> | <p>①-③ Turn the power off, and on again to check. If abnormality generates again, replace indoor controller board.</p> |
| Fb | <p>Indoor controller board</p> <p>Abnormal if data cannot be read normally from the nonvolatile memory of the indoor controller board.</p> | <p>① Defective indoor controller board</p> | <p>① Replace indoor controller board.</p> |
| E1 or E2 | <p>Remote controller control board</p> <p>① Abnormal if data cannot be read normally from the nonvolatile memory of the remote controller control board. (Error code: E1)</p> <p>② Abnormal if the clock function of remote controller cannot be operated normally. (Error code: E2)</p> | <p>① Defective remote controller</p> | <p>① Replace remote controller.</p> |
| PA | <p>Forced compressor stop (due to water leakage abnormality)</p> <p>① The unit has a water leakage abnormality when the following conditions, a) and b), are satisfied while the above-mentioned detection is performed.</p> <p>a) The intake temperature subtracted with liquid pipe temperature detects to be less than -10°C for a total of 30 minutes. (When the drain sensor is detected to be NOT soaked in the water, the detection record of a) and b) will be cleared.)</p> <p>b) Drain float switch detects to be in the water for more than 15 minutes.</p> <p>*Once the water leakage abnormality is detected, abnormality state will not be released until the main power is reset.</p> | <p>① Drain pump trouble</p> <p>② Drain defective · Drain pump clogging · Drain pipe clogging</p> <p>③ Open circuit of float switch</p> <p>④ Contact failure of float switch connector</p> <p>⑤ Dew condensation on float switch · Drain water descends along lead wire. · Drain water waving due to filter clogging.</p> <p>⑥ Extension piping connection difference at twin, triple, quadruple system.</p> <p>⑦ Miswiring of indoor/outdoor connecting at twin, triple, quadruple system.</p> <p>⑧ Room temperature thermistor/ liquid pipe temperature thermistor detection is defective.</p> | <p>① Check the drain pump.</p> <p>② Check whether water can be drained.</p> <p>③ Check the resistance of the float switch.</p> <p>④ Check the connector contact failure.</p> <p>⑤ Check the float switch leadwire mounted. Check the filter clogging.</p> <p>⑥ Check the piping connection.</p> <p>⑦ Check the indoor/outdoor connecting wires.</p> <p>⑧ Check the room temperature display of remote controller. Check the indoor liquid pipe temperature display of outdoor controller board.</p> |

9-4. TROUBLESHOOTING BY INFERIOR PHENOMENA

Note: Refer to the manual of outdoor unit for the detail of remote controller.

| Phenomena | Cause | Countermeasure |
|--|--|--|
| <p>(1)LED2 on indoor controller board is off.</p> | <ul style="list-style-type: none"> • When LED1 on indoor controller board is also off. ① Power supply of rated voltage is not supplied to outdoor unit. ② Defective outdoor controller circuit board ③ Power supply of 220~240V is not supplied to indoor unit. ④ Defective indoor controller board <p>(For the separate indoor/outdoor unit power supply system)</p> <ul style="list-style-type: none"> ① Power supply of 220~240V AC is not supplied to indoor unit. ② The connectors of the optional replacement kit are not used. ③ Defective indoor controller board | <ul style="list-style-type: none"> ① Check the voltage of outdoor power supply terminal block (L, N) or (L₃, N). <ul style="list-style-type: none"> • When AC 220~240V is not detected, check the power wiring to outdoor unit and the breaker. • When AC 220~240V is detected, check ② (below). ② Check the voltage between outdoor terminal block S1 and S2. <ul style="list-style-type: none"> • When AC 220~240V is not detected, —check the fuse on outdoor controller circuit board. —check the wiring connection. • When AC 220~240V is detected, check ③ (below). ③ Check the voltage between indoor terminal block S1 and S2. <ul style="list-style-type: none"> • When AC 220~240V is not detected, check indoor/outdoor unit connecting wire for miswiring. • When AC 220~240V is detected, check ④ (below). ④ Check the fuse on indoor controller board. Check the wiring connection. If no problem are found, indoor controller board is defective. <ul style="list-style-type: none"> ① Check the voltage of indoor power supply terminal block (L,N). <ul style="list-style-type: none"> • When AC220~240V is not detected, check the power supply wiring. • When AC220~240V is detected, check ② (below). ② Check that there is no problem in the method of connecting the connectors. <ul style="list-style-type: none"> • When there are problems in the method of connecting the connectors, connect the connector correctly referring to installation manual of an optional kit. • When there is no problem in the method of connecting the connectors, check ③ (below). ③ Check the fuse on indoor controller board. Check the wiring connection. If no problem are found, indoor controller board is defective. |
| | <ul style="list-style-type: none"> • When LED1 on indoor controller board is lit. ① Mis-setting of refrigerant address for outdoor unit (There is no unit corresponding to refrigerant address "0".) | <ul style="list-style-type: none"> ① Check again the setting of refrigerant address for outdoor unit. Set the refrigerant address to "0". (For grouping control system under which 2 or more outdoor units are connected, set one of the units to "0".) Set refrigerant address using SW1 (3-6) on outdoor controller circuit board. |

Note: Refer to the manual of outdoor unit for the detail of remote controller.

| Phenomena | Cause | Countermeasure |
|--|--|---|
| (2)LED2 on indoor controller board is blinking. | <ul style="list-style-type: none"> • When LED1 on indoor controller board is also blinking. Connection failure of indoor/outdoor unit connecting wire • When LED1 is lit. ① Miswiring of remote controller wires Under twin triple indoor unit system, 2 or more indoor units are wired together. ② Refrigerant address for outdoor unit is wrong or not set. Under grouping control system, there are some units whose refrigerant address is 0. ③ Short-cut of remote controller wires ④ Defective remote controller | <p>Check indoor/outdoor unit connecting wire for connection failure.</p> <ul style="list-style-type: none"> ① Check the connection of remote controller wires in case of twin triple indoor unit system. When 2 or more indoor units are wired in one refrigerant system, connect remote controller wires to one of those units. ② Check the setting of refrigerant address in case of grouping control system. If there are some units whose refrigerant addresses are 0 in one group, set one of the units to 0 using SW1 (3-6) on outdoor controller circuit board. ③④ Remove remote controller wires and check LED2 on indoor controller board. <ul style="list-style-type: none"> • When LED2 is blinking, check the short-cut of remote controller wires. • When LED2 is lit, connect remote controller wires again and: if LED2 is blinking, remote controller is defective; if LED2 is lit, connection failure of remote controller terminal block etc. has returned to normal. |
| (3)Upward/downward vane performance failure | <ul style="list-style-type: none"> ① The vane is not downward during defrosting and heat preparation and when the thermostat is OFF in HEAT mode. (Working of COOL protection function) ② Vane motor does not rotate. <ul style="list-style-type: none"> • Defective vane motor • Breaking of wire or connection failure of connector ③ Upward/downward vane does not work. <ul style="list-style-type: none"> • The vane is set to fixed position. | <ul style="list-style-type: none"> ① Normal operation (The vane is set to horizontal regardless of remote control.) ② Check ② (left). <ul style="list-style-type: none"> • Check the vane motor. (Refer to "How to check the parts".) • Check for breaking of wire or connection failure of connector. ③ Normal operation (Each connector on vane motor side is disconnected or setting the fixed vanes by wired remote controller.) |
| (4)Receiver for wireless remote controller | <ul style="list-style-type: none"> ① Weak batteries of wireless remote controller. ② Contact failure of connector (CNB) on wireless remote controller board (Insert failure) ③ Contact failure of connector (CN90) on indoor controller board (Insert failure) ④ Contact failure of connector between wireless remote controller board and indoor controller board | <ul style="list-style-type: none"> ① Replace batteries of wireless remote controller. ②~④ Check contact failure of each connector. If no problems are found of connector, replace indoor controller board. When the same trouble occurs even if indoor controller board is replaced, replace wireless remote controller board. |

9-5. EMERGENCY OPERATION

9-5-1. When wireless remote controller fails or its battery is exhausted

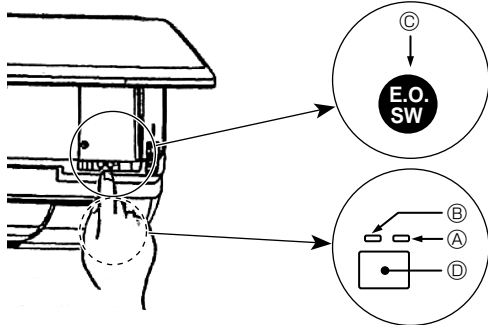

When the remote controller cannot be used

When the batteries of the remote controller run out or the remote controller malfunctions, the emergency operation can be done using the emergency buttons.

- (A) DEFROST/STAND BY lamp (ORANGE)
- (B) Operation lamp (GREEN)
- (C) Emergency operation switch (cooling/heating)
- (D) Receiver

- Each press of the emergency operation switch will toggle the operation mode.
- Check "COOL/HEAT" with the operation monitor display. (The display will appear orange for 5 seconds after pressing the emergency operation switch.)

[Heat pump type]

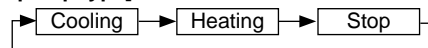

[Cooling Only type]

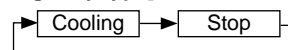

Operation Monitor Display

| | GREEN | ORANGE | |
|------|-------|--------|---|
| STOP | ○ | ○ | The orange lamp follows the switch operation as indicated at the left for 5 seconds, and then it will return to the normal display. |
| COOL | ● | ○ | |
| HEAT | ● | ● | |

○ Turning off ● Lighting

* Details of emergency mode are as shown below.

| Operation Mod | COOL | HEAT |
|-------------------------------|------------|----------|
| Set Temperature | 24°C | 24°C |
| Fan Speed | High | High |
| Airflow Direction Up and Down | Horizontal | Downward |

9-5-2. When wired remote controller or indoor unit microcomputer fails

1. When the wired remote control or the indoor unit microcomputer has failed, but all other components work properly, if you set the switch (SWE) on the indoor controller board ON, the indoor unit will begin Emergency Operation.

When Emergency Operation is activated, the indoor unit operates as follows:

- (1) Indoor fan is running at high speed. (2) Drain pump is working. (option)

※ Note on the wireless remote control

When the remote control does not function, it is possible to activate Emergency Operation by using the indoor unit Emergency Operation switch.

However, if the indoor unit microcomputer has failed, it is necessary to proceed with points 2 and 3 below as in the case of the wired remote control.

2. When you activate Emergency Operation of the cooling or heating, you have to set the switch (SWE) on the indoor controller board and activate Emergency Operation of the outdoor unit.

For details on how to activate Emergency Operation of the outdoor unit, refer to the outdoor unit wiring diagram.

3. Before you activate Emergency Operation, check the following points:

- (1) Emergency operation cannot be activated when:

- the outdoor unit malfunctions. • the indoor fan malfunctions.
- when it has detected the malfunction of drain-up machine during self-diagnosing.

- (2) Emergency Operation becomes continuous only by switching the power source on/off.

ON/OFF on the remote control or temperature control etc. does not function.

- (3) Avoid operating for a long time when the outdoor unit begins defrosting while Emergency Operation of the heating is activated, because it will start to blow cold air.

- (4) Emergency cooling should be limited to 10 hours maximum (The indoor unit heat exchanger may freeze).

- (5) After Emergency Operation has been deactivated, set the switches etc. to their original positions.

- (6) Movement of the vanes does not work in Emergency operation, therefore you have to slowly set them manually to the appropriate position.

9-6. HOW TO CHECK THE PARTS

PKA-RP35HAL PKA-RP50HAL

| Parts name | Check points | | | | | | | | | | | | | | |
|--|--|---------------------|--------------------|---------------|---------------|----------|------------------|---------------------|---------------------|--------------------|---------------|-----------|--|--|--|
| Room temperature thermistor (TH1) Liquid pipe temperature thermistor (TH2) Condenser / Evaporator temperature thermistor (TH5) | <p>Disconnect the connector then measure the resistance using a tester. (At the ambient temperature 10°C~30°C)</p> <table border="1"> <thead> <tr> <th>Normal</th> <th>Abnormal</th> </tr> </thead> <tbody> <tr> <td>4.3kΩ~9.6kΩ</td> <td>Open or short</td> </tr> </tbody> </table> <p>Refer to the thermistor.</p> | Normal | Abnormal | 4.3kΩ~9.6kΩ | Open or short | | | | | | | | | | |
| Normal | Abnormal | | | | | | | | | | | | | | |
| 4.3kΩ~9.6kΩ | Open or short | | | | | | | | | | | | | | |
| Vane motor (MV) | <p>Measure the resistance between the terminals using a tester. (Coil temperature 25°C)</p> <table border="1"> <thead> <tr> <th colspan="4">Normal</th> <th>Abnormal</th> </tr> </thead> <tbody> <tr> <td>①-② Brown-Red</td> <td>①-③ Brown-Orange</td> <td>①-④ Brown-Yellow</td> <td>①-⑤ Brown-Green</td> <td rowspan="2">Open or short</td> </tr> <tr> <td colspan="4">350Ω ± 7%</td> </tr> </tbody> </table> | Normal | | | | Abnormal | ①-② Brown-Red | ①-③ Brown-Orange | ①-④ Brown-Yellow | ①-⑤ Brown-Green | Open or short | 350Ω ± 7% | | | |
| Normal | | | | Abnormal | | | | | | | | | | | |
| ①-② Brown-Red | ①-③ Brown-Orange | ①-④ Brown-Yellow | ①-⑤ Brown-Green | Open or short | | | | | | | | | | | |
| 350Ω ± 7% | | | | | | | | | | | | | | | |
| Fan motor (MF) | Refer to 9-6-2. | | | | | | | | | | | | | | |

9-6-1. Thermistor

<Thermistor Characteristic graph>

Thermistor for lower temperature

Room temperature thermistor (TH1)
Pipe temperature thermistor/liquid (TH2)
Condenser/evaporator temperature thermistor (TH5)

Thermistor $R_0=15k\Omega \pm 3\%$
Fixed number of $B=3480 \pm 2\%$

$$R_t=15\exp \left\{ 3480 \left(\frac{1}{273+t} - \frac{1}{273} \right) \right\}$$

| | |
|------|-------|
| 0°C | 15kΩ |
| 10°C | 9.6kΩ |
| 20°C | 6.3kΩ |
| 25°C | 5.4kΩ |
| 30°C | 4.3kΩ |
| 40°C | 3.0kΩ |

< Thermistor for lower temperature >

| Temperature (°C) | Resistance (kΩ) |
|------------------|-----------------|
| -20 | 45 |
| -10 | 30 |
| 0 | 18 |
| 10 | 12 |
| 20 | 8 |
| 30 | 5.5 |
| 40 | 4 |
| 50 | 3 |



9-6-2. DC Fan motor (fan motor/indoor controller circuit board)

Check method of DC fan motor (fan motor/indoor controller circuit board)

① Notes

- High voltage is applied to the connector (CNMF) for the fan motor. Pay attention to the service.
- Do not pull out the connector (CNMF) for the motor with the power supply on.
(It causes trouble of the indoor controller circuit board and fan motor.)

② Self check

Symptom : The indoor fan cannot turn around.

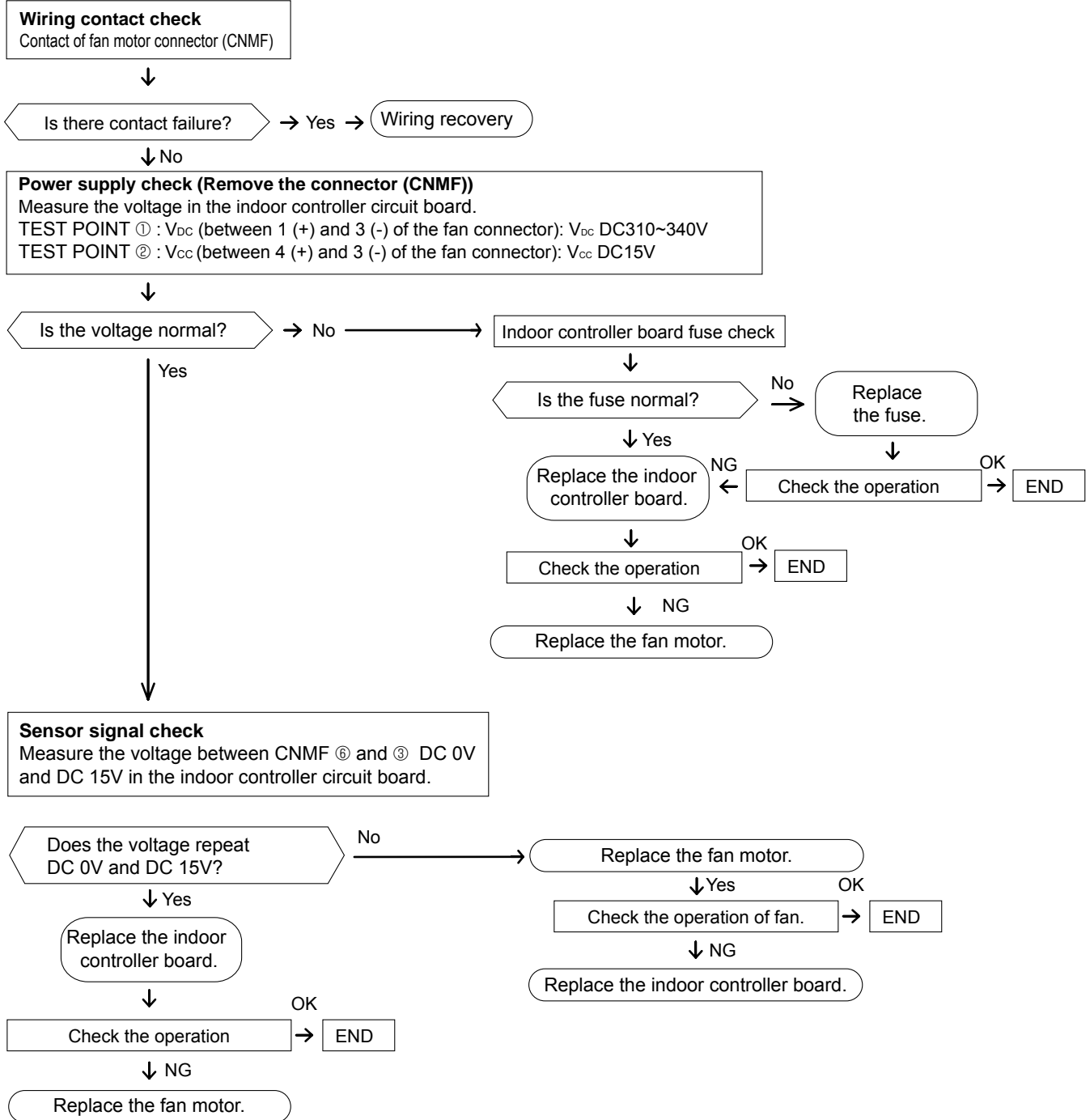

9-7. TEST POINT DIAGRAM

Indoor controller board

PKA-RP35HAL PKA-RP50HAL

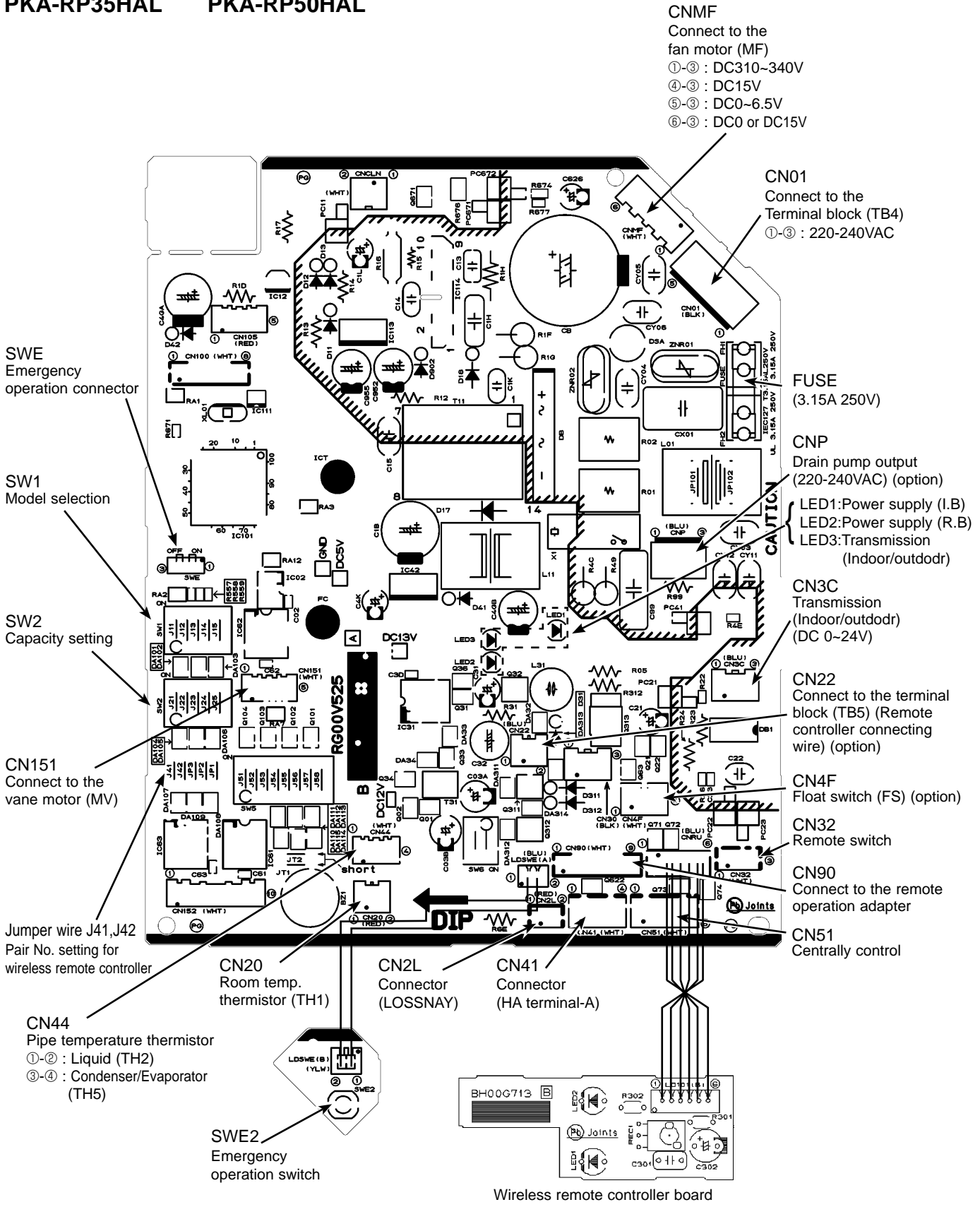

CNM1
Connect to the fan motor (MF)
①-③ : DC310~340V
④-③ : DC15V
⑤-③ : DC0~6.5V
⑥-③ : DC0 or DC15V

CN01
Connect to the Terminal block (TB4)
①-③ : 220-240VAC

FUSE
(3.15A 250V)

CNP
Drain pump output (220-240VAC) (option)
LED1: Power supply (I.B)
LED2: Power supply (R.B)
LED3: Transmission (Indoor/outdoor)

CN3C
Transmission (Indoor/outdoor) (DC 0~24V)

CN22
Connect to the terminal block (TB5) (Remote controller connecting wire) (option)

CN4F
Float switch (FS) (option)

CN32
Remote switch

CN90
Connect to the remote operation adapter

CN51
Centrally control

SWE
Emergency operation connector

SW1
Model selection

SW2
Capacity setting

CN151
Connect to the vane motor (MV)

Jumper wire J41, J42
Pair No. setting for wireless remote controller

CN44
Pipe temperature thermistor
①-② : Liquid (TH2)
③-④ : Condenser/Evaporator (TH5)

SWE2
Emergency operation switch

CN20
Room temp. thermistor (TH1)

CN2L
Connector (LOSSNAY)

CN41
Connector (HA terminal-A)

Wireless remote controller board

9-8. FUNCTIONS OF DIP SWITCH AND JUMPER WIRE

Each function is controlled by the dip switch and the jumper wire on control P.C. board.

(Marks in the table below) Jumper wire (○ : Short × : Open)

| Jumper wire | Functions | Setting by the dip switch and jumper wire | Remarks | | | | | | | | | | | | | | | | | | | | | | | | | | | | | | | | | | | | | | | | | | |
|-------------------------------------|---|---|-------------------------------------|-------------------------------------|-------------|---|---------------|-------------------------------------|--|-------------------------------------|-------------------------------------|-------------------------------------|-------------------------------------|-------------------------------------|-------------------------------------|-------------------------------------|-------------------------------------|--------------------------|--------------------------|---|--------------------------|--------------------------|--------------------------|-----|-------------|---|---|---|---|---|---|--------|-------------------------------------|-------------------------------------|-------------------------------------|-------------------------------------|-------------------------------------|----|--------------------------|--------------------------|--------------------------|--------------------------|--------------------------|-----|--|
| SW1 | Model settings | <table border="1"> <thead> <tr> <th>MODELS</th> <th>SETTING</th> </tr> </thead> <tbody> <tr> <td>PKA-RP·HAL</td> <td> <table border="1"> <thead> <tr> <th>1</th> <th>2</th> <th>3</th> <th>4</th> <th>5</th> <th>ON/OFF</th> </tr> </thead> <tbody> <tr> <td><input checked="" type="checkbox"/></td> <td><input checked="" type="checkbox"/></td> <td><input checked="" type="checkbox"/></td> <td><input checked="" type="checkbox"/></td> <td><input checked="" type="checkbox"/></td> <td>ON</td> </tr> <tr> <td><input type="checkbox"/></td> <td><input type="checkbox"/></td> <td><input type="checkbox"/></td> <td><input type="checkbox"/></td> <td><input type="checkbox"/></td> <td>OFF</td> </tr> </tbody> </table> </td> </tr> </tbody> </table> | MODELS | SETTING | PKA-RP·HAL | <table border="1"> <thead> <tr> <th>1</th> <th>2</th> <th>3</th> <th>4</th> <th>5</th> <th>ON/OFF</th> </tr> </thead> <tbody> <tr> <td><input checked="" type="checkbox"/></td> <td><input checked="" type="checkbox"/></td> <td><input checked="" type="checkbox"/></td> <td><input checked="" type="checkbox"/></td> <td><input checked="" type="checkbox"/></td> <td>ON</td> </tr> <tr> <td><input type="checkbox"/></td> <td><input type="checkbox"/></td> <td><input type="checkbox"/></td> <td><input type="checkbox"/></td> <td><input type="checkbox"/></td> <td>OFF</td> </tr> </tbody> </table> | 1 | 2 | 3 | 4 | 5 | ON/OFF | <input checked="" type="checkbox"/> | <input checked="" type="checkbox"/> | <input checked="" type="checkbox"/> | <input checked="" type="checkbox"/> | <input checked="" type="checkbox"/> | ON | <input type="checkbox"/> | <input type="checkbox"/> | <input type="checkbox"/> | <input type="checkbox"/> | <input type="checkbox"/> | OFF | | | | | | | | | | | | | | | | | | | | | |
| MODELS | SETTING | | | | | | | | | | | | | | | | | | | | | | | | | | | | | | | | | | | | | | | | | | | | |
| PKA-RP·HAL | <table border="1"> <thead> <tr> <th>1</th> <th>2</th> <th>3</th> <th>4</th> <th>5</th> <th>ON/OFF</th> </tr> </thead> <tbody> <tr> <td><input checked="" type="checkbox"/></td> <td><input checked="" type="checkbox"/></td> <td><input checked="" type="checkbox"/></td> <td><input checked="" type="checkbox"/></td> <td><input checked="" type="checkbox"/></td> <td>ON</td> </tr> <tr> <td><input type="checkbox"/></td> <td><input type="checkbox"/></td> <td><input type="checkbox"/></td> <td><input type="checkbox"/></td> <td><input type="checkbox"/></td> <td>OFF</td> </tr> </tbody> </table> | 1 | 2 | 3 | 4 | 5 | ON/OFF | <input checked="" type="checkbox"/> | <input checked="" type="checkbox"/> | <input checked="" type="checkbox"/> | <input checked="" type="checkbox"/> | <input checked="" type="checkbox"/> | ON | <input type="checkbox"/> | <input type="checkbox"/> | <input type="checkbox"/> | <input type="checkbox"/> | <input type="checkbox"/> | OFF | | | | | | | | | | | | | | | | | | | | | | | | | | |
| 1 | 2 | 3 | 4 | 5 | ON/OFF | | | | | | | | | | | | | | | | | | | | | | | | | | | | | | | | | | | | | | | | |
| <input checked="" type="checkbox"/> | <input checked="" type="checkbox"/> | <input checked="" type="checkbox"/> | <input checked="" type="checkbox"/> | <input checked="" type="checkbox"/> | ON | | | | | | | | | | | | | | | | | | | | | | | | | | | | | | | | | | | | | | | | |
| <input type="checkbox"/> | <input type="checkbox"/> | <input type="checkbox"/> | <input type="checkbox"/> | <input type="checkbox"/> | OFF | | | | | | | | | | | | | | | | | | | | | | | | | | | | | | | | | | | | | | | | |
| SW2 | Capacity settings | <table border="1"> <thead> <tr> <th>MODELS</th> <th>SETTING</th> </tr> </thead> <tbody> <tr> <td>PKA-RP35HAL</td> <td> <table border="1"> <thead> <tr> <th>1</th> <th>2</th> <th>3</th> <th>4</th> <th>5</th> <th>ON/OFF</th> </tr> </thead> <tbody> <tr> <td><input checked="" type="checkbox"/></td> <td><input checked="" type="checkbox"/></td> <td><input checked="" type="checkbox"/></td> <td><input checked="" type="checkbox"/></td> <td><input checked="" type="checkbox"/></td> <td>ON</td> </tr> <tr> <td><input type="checkbox"/></td> <td><input type="checkbox"/></td> <td><input type="checkbox"/></td> <td><input type="checkbox"/></td> <td><input type="checkbox"/></td> <td>OFF</td> </tr> </tbody> </table> </td> </tr> <tr> <td>PKA-RP50HAL</td> <td> <table border="1"> <thead> <tr> <th>1</th> <th>2</th> <th>3</th> <th>4</th> <th>5</th> <th>ON/OFF</th> </tr> </thead> <tbody> <tr> <td><input checked="" type="checkbox"/></td> <td><input checked="" type="checkbox"/></td> <td><input checked="" type="checkbox"/></td> <td><input checked="" type="checkbox"/></td> <td><input checked="" type="checkbox"/></td> <td>ON</td> </tr> <tr> <td><input type="checkbox"/></td> <td><input type="checkbox"/></td> <td><input type="checkbox"/></td> <td><input type="checkbox"/></td> <td><input type="checkbox"/></td> <td>OFF</td> </tr> </tbody> </table> </td> </tr> </tbody> </table> | MODELS | SETTING | PKA-RP35HAL | <table border="1"> <thead> <tr> <th>1</th> <th>2</th> <th>3</th> <th>4</th> <th>5</th> <th>ON/OFF</th> </tr> </thead> <tbody> <tr> <td><input checked="" type="checkbox"/></td> <td><input checked="" type="checkbox"/></td> <td><input checked="" type="checkbox"/></td> <td><input checked="" type="checkbox"/></td> <td><input checked="" type="checkbox"/></td> <td>ON</td> </tr> <tr> <td><input type="checkbox"/></td> <td><input type="checkbox"/></td> <td><input type="checkbox"/></td> <td><input type="checkbox"/></td> <td><input type="checkbox"/></td> <td>OFF</td> </tr> </tbody> </table> | 1 | 2 | 3 | 4 | 5 | ON/OFF | <input checked="" type="checkbox"/> | <input checked="" type="checkbox"/> | <input checked="" type="checkbox"/> | <input checked="" type="checkbox"/> | <input checked="" type="checkbox"/> | ON | <input type="checkbox"/> | <input type="checkbox"/> | <input type="checkbox"/> | <input type="checkbox"/> | <input type="checkbox"/> | OFF | PKA-RP50HAL | <table border="1"> <thead> <tr> <th>1</th> <th>2</th> <th>3</th> <th>4</th> <th>5</th> <th>ON/OFF</th> </tr> </thead> <tbody> <tr> <td><input checked="" type="checkbox"/></td> <td><input checked="" type="checkbox"/></td> <td><input checked="" type="checkbox"/></td> <td><input checked="" type="checkbox"/></td> <td><input checked="" type="checkbox"/></td> <td>ON</td> </tr> <tr> <td><input type="checkbox"/></td> <td><input type="checkbox"/></td> <td><input type="checkbox"/></td> <td><input type="checkbox"/></td> <td><input type="checkbox"/></td> <td>OFF</td> </tr> </tbody> </table> | 1 | 2 | 3 | 4 | 5 | ON/OFF | <input checked="" type="checkbox"/> | <input checked="" type="checkbox"/> | <input checked="" type="checkbox"/> | <input checked="" type="checkbox"/> | <input checked="" type="checkbox"/> | ON | <input type="checkbox"/> | <input type="checkbox"/> | <input type="checkbox"/> | <input type="checkbox"/> | <input type="checkbox"/> | OFF | |
| MODELS | SETTING | | | | | | | | | | | | | | | | | | | | | | | | | | | | | | | | | | | | | | | | | | | | |
| PKA-RP35HAL | <table border="1"> <thead> <tr> <th>1</th> <th>2</th> <th>3</th> <th>4</th> <th>5</th> <th>ON/OFF</th> </tr> </thead> <tbody> <tr> <td><input checked="" type="checkbox"/></td> <td><input checked="" type="checkbox"/></td> <td><input checked="" type="checkbox"/></td> <td><input checked="" type="checkbox"/></td> <td><input checked="" type="checkbox"/></td> <td>ON</td> </tr> <tr> <td><input type="checkbox"/></td> <td><input type="checkbox"/></td> <td><input type="checkbox"/></td> <td><input type="checkbox"/></td> <td><input type="checkbox"/></td> <td>OFF</td> </tr> </tbody> </table> | 1 | 2 | 3 | 4 | 5 | ON/OFF | <input checked="" type="checkbox"/> | <input checked="" type="checkbox"/> | <input checked="" type="checkbox"/> | <input checked="" type="checkbox"/> | <input checked="" type="checkbox"/> | ON | <input type="checkbox"/> | <input type="checkbox"/> | <input type="checkbox"/> | <input type="checkbox"/> | <input type="checkbox"/> | OFF | | | | | | | | | | | | | | | | | | | | | | | | | | |
| 1 | 2 | 3 | 4 | 5 | ON/OFF | | | | | | | | | | | | | | | | | | | | | | | | | | | | | | | | | | | | | | | | |
| <input checked="" type="checkbox"/> | <input checked="" type="checkbox"/> | <input checked="" type="checkbox"/> | <input checked="" type="checkbox"/> | <input checked="" type="checkbox"/> | ON | | | | | | | | | | | | | | | | | | | | | | | | | | | | | | | | | | | | | | | | |
| <input type="checkbox"/> | <input type="checkbox"/> | <input type="checkbox"/> | <input type="checkbox"/> | <input type="checkbox"/> | OFF | | | | | | | | | | | | | | | | | | | | | | | | | | | | | | | | | | | | | | | | |
| PKA-RP50HAL | <table border="1"> <thead> <tr> <th>1</th> <th>2</th> <th>3</th> <th>4</th> <th>5</th> <th>ON/OFF</th> </tr> </thead> <tbody> <tr> <td><input checked="" type="checkbox"/></td> <td><input checked="" type="checkbox"/></td> <td><input checked="" type="checkbox"/></td> <td><input checked="" type="checkbox"/></td> <td><input checked="" type="checkbox"/></td> <td>ON</td> </tr> <tr> <td><input type="checkbox"/></td> <td><input type="checkbox"/></td> <td><input type="checkbox"/></td> <td><input type="checkbox"/></td> <td><input type="checkbox"/></td> <td>OFF</td> </tr> </tbody> </table> | 1 | 2 | 3 | 4 | 5 | ON/OFF | <input checked="" type="checkbox"/> | <input checked="" type="checkbox"/> | <input checked="" type="checkbox"/> | <input checked="" type="checkbox"/> | <input checked="" type="checkbox"/> | ON | <input type="checkbox"/> | <input type="checkbox"/> | <input type="checkbox"/> | <input type="checkbox"/> | <input type="checkbox"/> | OFF | | | | | | | | | | | | | | | | | | | | | | | | | | |
| 1 | 2 | 3 | 4 | 5 | ON/OFF | | | | | | | | | | | | | | | | | | | | | | | | | | | | | | | | | | | | | | | | |
| <input checked="" type="checkbox"/> | <input checked="" type="checkbox"/> | <input checked="" type="checkbox"/> | <input checked="" type="checkbox"/> | <input checked="" type="checkbox"/> | ON | | | | | | | | | | | | | | | | | | | | | | | | | | | | | | | | | | | | | | | | |
| <input type="checkbox"/> | <input type="checkbox"/> | <input type="checkbox"/> | <input type="checkbox"/> | <input type="checkbox"/> | OFF | | | | | | | | | | | | | | | | | | | | | | | | | | | | | | | | | | | | | | | | |
| J41 J42 | Pair number setting with wireless remote controller | <table border="1"> <thead> <tr> <th rowspan="2">Wireless remote controller setting</th> <th colspan="2">Control PCB setting</th> </tr> <tr> <th>J41</th> <th>J42</th> </tr> </thead> <tbody> <tr> <td>0</td> <td>○</td> <td>○</td> </tr> <tr> <td>1</td> <td>×</td> <td>○</td> </tr> <tr> <td>2</td> <td>○</td> <td>×</td> </tr> <tr> <td>3 ~ 9</td> <td>×</td> <td>×</td> </tr> </tbody> </table> | Wireless remote controller setting | Control PCB setting | | J41 | J42 | 0 | ○ | ○ | 1 | × | ○ | 2 | ○ | × | 3 ~ 9 | × | × | <p><Initial setting> Wireless remote controller: 0 Control PCB: ○ (for both J41 and J42) 4 pair number settings are supported. The pair number settings of the wireless remote controller and indoor control PCB (J41/J42) are given in the table on the left. ('×' in the table indicates the jumper wire is disconnected.)</p> | | | | | | | | | | | | | | | | | | | | | | | | | |
| Wireless remote controller setting | Control PCB setting | | | | | | | | | | | | | | | | | | | | | | | | | | | | | | | | | | | | | | | | | | | | |
| | J41 | J42 | | | | | | | | | | | | | | | | | | | | | | | | | | | | | | | | | | | | | | | | | | | |
| 0 | ○ | ○ | | | | | | | | | | | | | | | | | | | | | | | | | | | | | | | | | | | | | | | | | | | |
| 1 | × | ○ | | | | | | | | | | | | | | | | | | | | | | | | | | | | | | | | | | | | | | | | | | | |
| 2 | ○ | × | | | | | | | | | | | | | | | | | | | | | | | | | | | | | | | | | | | | | | | | | | | |
| 3 ~ 9 | × | × | | | | | | | | | | | | | | | | | | | | | | | | | | | | | | | | | | | | | | | | | | | |
| JP3 | Indoor controller board type setting | <table border="1"> <thead> <tr> <th>Indoor controller board type</th> <th>JP3</th> </tr> </thead> <tbody> <tr> <td>For product</td> <td>○</td> </tr> <tr> <td>Service parts</td> <td>○</td> </tr> </tbody> </table> | Indoor controller board type | JP3 | For product | ○ | Service parts | ○ | <p>○ : With JP3 × : Without JP3</p> | | | | | | | | | | | | | | | | | | | | | | | | | | | | | | | | | | | | |
| Indoor controller board type | JP3 | | | | | | | | | | | | | | | | | | | | | | | | | | | | | | | | | | | | | | | | | | | | |
| For product | ○ | | | | | | | | | | | | | | | | | | | | | | | | | | | | | | | | | | | | | | | | | | | | |
| Service parts | ○ | | | | | | | | | | | | | | | | | | | | | | | | | | | | | | | | | | | | | | | | | | | | |

10-1. ROTATION FUNCTION(AND BACK-UP FUNCTION, 2ND STAGE CUT-IN FUNCTION)

Optional wired remote controller with terminal bed (PAR-21MAAT-E) are necessary for PKA type.

10-1-1. Operation

(1) Rotation function (and Back-up function)

• **Outline of functions**

- Main and sub unit operate alternately according to the interval of rotation setting.
- ※ Main and sub unit should be set by refrigerant address. (Outdoor Dip switch setting)
 Refrigerant address"00" → Main unit
 Refrigerant address"01" → Sub unit
- When error occurs to one unit, another unit will start operation. (Back-up function)

• **System constraint**

- This function is available only by the grouping control system(INDOOR UNIT : OUTDOOR UNIT=1:1) of 2 refrigerant groups. (Refer to Fig. 1)
- Main indoor unit should be connected for wired remote controller and the transmission line (TB5) for main and sub unit should also be connected. (Refer to Fig. 1)
 (This function cannot be set by wireless remote controller.)
- Set refrigerant address of each unit. (Dip switch on the outdoor unit--Refrigerant address 00/01)

Operation pattern

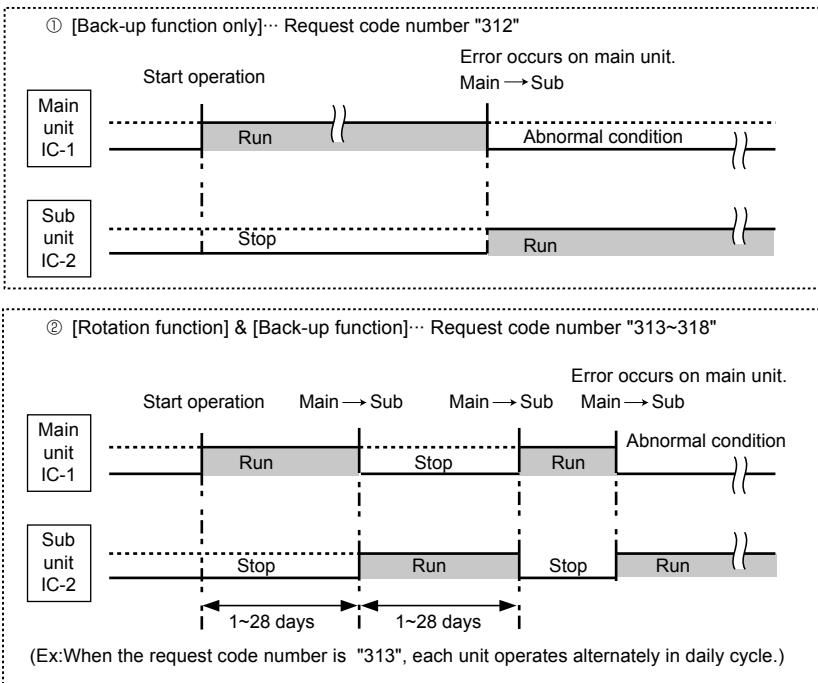
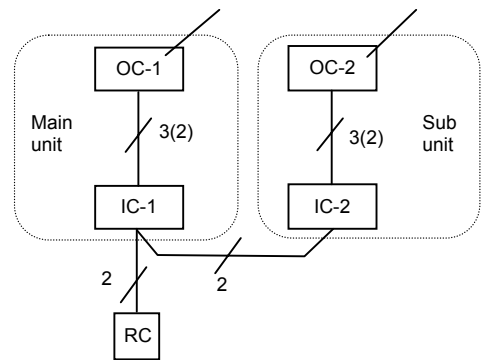

Fig. 1 Refrigerant address "00" Refrigerant address "01"



OC : Outdoor unit
 IC : Indoor unit
 RC : Wired remote controller

Note:

- When the unit is restarted to operate after turning off the power or OFF operation, the unit which was operating will start operation.
- To operate the main unit, refer to the 10-1-2. and set the request code No. which is not the same as the current one, and set again the former request code No.

(2) 2nd stage cut-in function

Outline of functions

- When the 1st unit can NOT supply with sufficient capacity for exceptionally high-demand conditions and the actual room temperature reaches set point *, the 2nd unit starts operation in conjunction with the 1st unit.
- Once the actual room temperature goes down to 4degrees C below set point *, the 2nd unit stops operation automatically. (* set point = set temperature by R/C (remote controller) + 4, 6, 8°C (selectable))
- Number of operating units is determined according to the room temperature and set point.
- When room temperature becomes higher than set point, standby unit starts. (2 units operation)
- When room temperature falls below set point -4°C, standby unit stops. (1 unit operation)

• **System constraint**

- This function is available only in cooling mode.

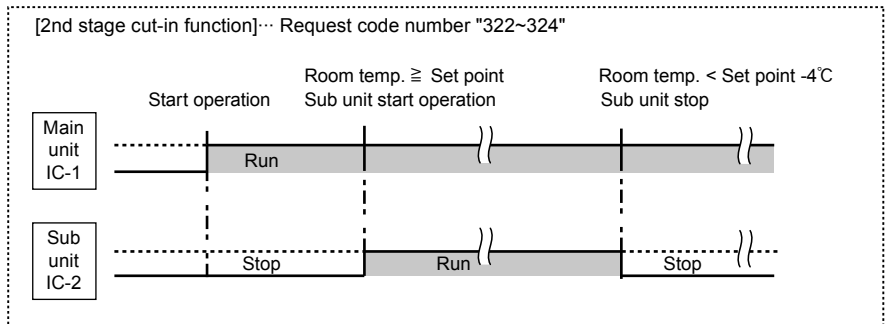
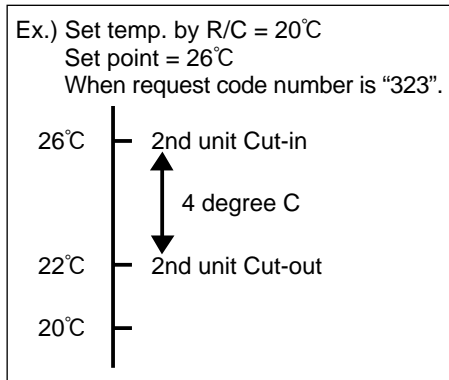

10-1-2. How to set rotation function(Back-up function, 2nd stage cut-in function)

You can set these functions by wired remote controller.(Maintenance monitor)

NOTICE

Both main and sub unit should be set in same setting.
Every time replacing indoor controller board for servicing, the function should be set again.

(1) Request Code List

Rotation setting

| Setting No. (Request code) | Setting contents | Initial setting |
|-------------------------------|--|-----------------|
| No.1 (310) | Monitoring the request code of current setting. | |
| No.2 (311) | Rotation and Back-up OFF (Normal group control operation) | ☉ |
| No.3 (312) | Back-up function only | |
| No.4 (313) | Rotation ON (Alternating interval = 1day) and back-up function | |
| No.5 (314) | Rotation ON (Alternating interval = 3days) and back-up function | |
| No.6 (315) | Rotation ON (Alternating interval = 5days) and back-up function | |
| No.7 (316) | Rotation ON (Alternating interval = 7days) and back-up function | |
| No.8 (317) | Rotation ON (Alternating interval = 14days) and back-up function | |
| No.9 (318) | Rotation ON (Alternating interval = 28days) and back-up function | |

2nd unit cut-in setting

| Setting No. (Request code) | Setting contents | Initial setting |
|-------------------------------|--|-----------------|
| No.1 (320) | Monitoring the request code of current setting. | |
| No.2 (321) | Cut-in function OFF | ☉ |
| No.3 (322) | Cut-in function ON(Set point = Set temp.+ 4°C (7.2F)) | |
| No.4 (323) | Cut-in function ON(Set point = Set temp.+ 6°C (10.8F)) | |
| No.5 (324) | Cut-in function ON(Set point = Set temp.+ 8°C (14.4F)) | |

(2) Setting method of each function by wired remote controller

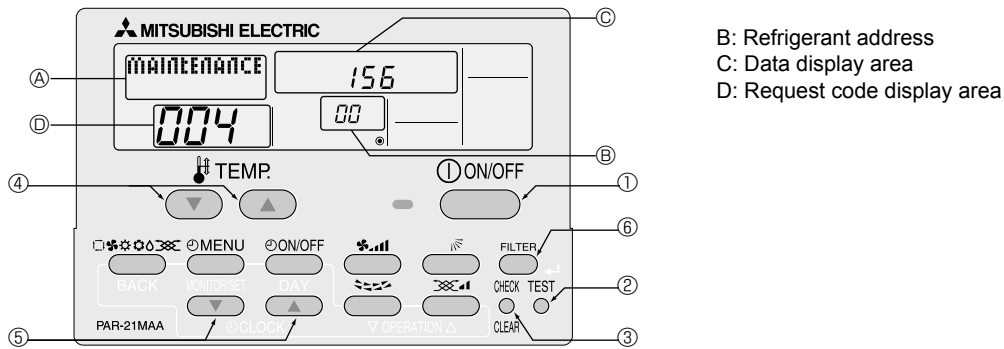

1. Stop operation(①).
2. Press the **TEST** button (②) for 3 seconds so that [Maintenance mode] appears on the screen (A).
After a while, [00] appears in the refrigerant address number display area.(at B)
3. Press the **CHECK** button (③) for 3 seconds to switch to [Maintenance monitor].
Note) It is not possible to switch to [Maintenance monitor] during data request in maintenance mode (i.e., while "----" is blinking) since no buttons are operative.

[----] appears on the screen (D) when [Maintenance monitor] is activated.
(The display (D) now allows you to set a request code No.)

4. Press the [TEMP (∇ and \triangle)] buttons (④) to select the desired refrigerant address.

[ScreenB] \rightarrow **00** \leftrightarrow **01** \leftrightarrow \leftrightarrow **15** \leftarrow

5. Press the [CLOCK (∇ and \triangle)] buttons (⑤) to set the desired request code No.("311~318", "321~324")
6. Press the **FILTER** button (⑥) to perform function setting.
If above setting operations are done correctly, "Request code number will appear in data display area.(C)
[Example: When the "311" of "Request code number" is set, [311] appears on the screen.(C)]

[Reference]

You can check current "request code number" setting by setting the "request code number"("310" or "320") and pressing the **FILTER** button.(⑥)
[Example: When the current setting is "Setting No.2(Request code 311)", [311] appears on the screen.(C)]

7. To return to normal mode, press the **ON/OFF** button (①).

PKA-RP35HAL

PKA-RP50HAL

Be careful when removing heavy parts.

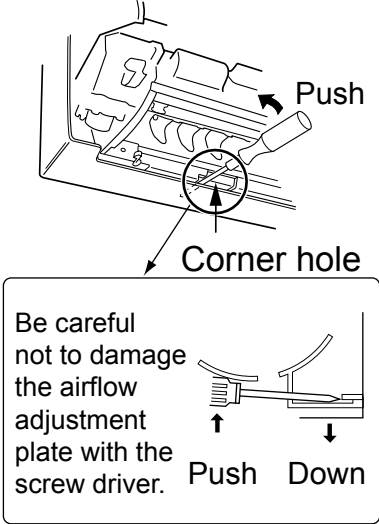
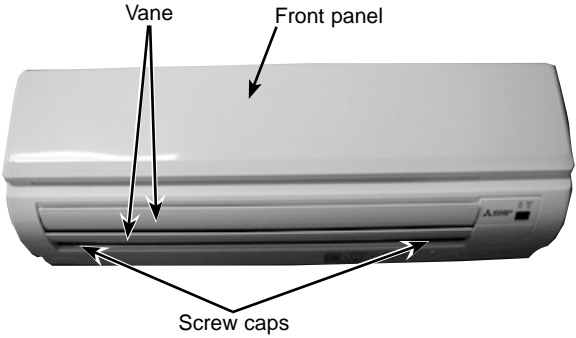
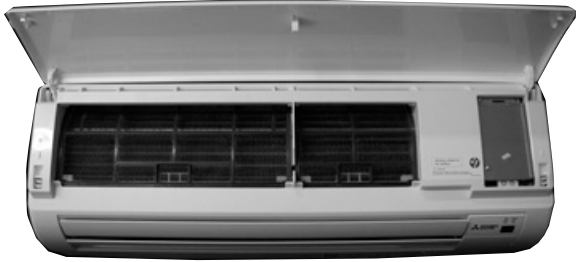
| OPERATION PROCEDURE | PHOTOS & ILLUSTRATIONS |
|--|---|
| <p>1. REMOVING THE LOWER SIDE OF THE INDOOR UNIT FROM THE INSTALLATION PLATE</p> <ol style="list-style-type: none"> (1) Remove the front panel. (2) Insert the screw driver to the corner hole at both left and right side as shown in the figure 1. (3) Push it up, then pull down the lower side of indoor unit and remove the hook. | <p>Figure 1</p>  |
| <p>2. REMOVING THE FRONT PANEL</p> <ol style="list-style-type: none"> (1) Press and unlock the knobs on both sides of the front panel and lift the front panel until it is level. Pull the hinges forward to remove the front panel. (See Photo 2) (2) Move the horizontal vanes in a downward direction. (3) Remove the screw caps of the panel. Remove the screws. (See Photo 1) (4) Hold the lower part of both ends of the panel and pull it slightly toward you, and then remove the panel by pushing it upward. | <p>Photo 1</p>  <p>Photo 2</p>  |

OPERATION PROCEDURE

3. REMOVING THE INDOOR CONTROLLER BOARD AND WIRELESS CONTROLLER BOARD

- (1) Remove the front panel. (Refer to 2.)
- (2) Remove the room temp. thermistor TH1. (see Photo 3)
- (3) Remove the electrical box covers (screw 4 × 12). (See Photo 3)
- (4) Disconnect the connectors on the indoor controller board.
- (5) Remove the switch board cover.
- (6) Pull out the indoor controller board toward you, then disconnect the rest of connectors.
Remove the indoor controller board and switch board.
- (7) Remove the holder of wireless controller board.
- (8) Disconnect the connector of wireless controller board and remove the wireless controller board from the holder.

Photo 5 Screw of electrical box cover (side) & clamp

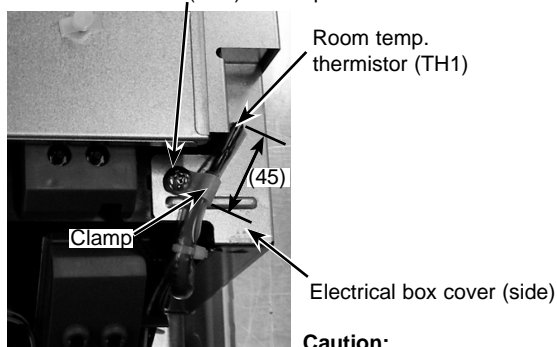

Caution:
In the case that room temp. thermistor is fixed with the screw of electrical box cover (side), keep 45mm between the bottom end of clamp and the top of room temp. thermistor as Photo 5.

4. REMOVING THE ELECTRICAL BOX

- (1) Remove the front panel. (Refer to 2.)
- (2) Remove the electrical box covers. (See Photo 3)
- (3) Remove the nozzle assembly. (Refer to 5.)
- (4) Disconnect the indoor/outdoor connecting wire from terminal block (TB4).
- (5) Disconnect the connectors on the indoor controller board.
- (6) Disconnect the connector for the ground wire. (See Photo 6)
- (7) Pull the disconnected lead wire out from the electrical box.
- (8) Remove the screw of electrical box. (See Photo 7)
- (9) Push up the upper fixture (See Photo 6) catch to remove the box, then pull the right fixture (See Photo 4) and remove it from the box fixture.

PHOTOS

Photo 3

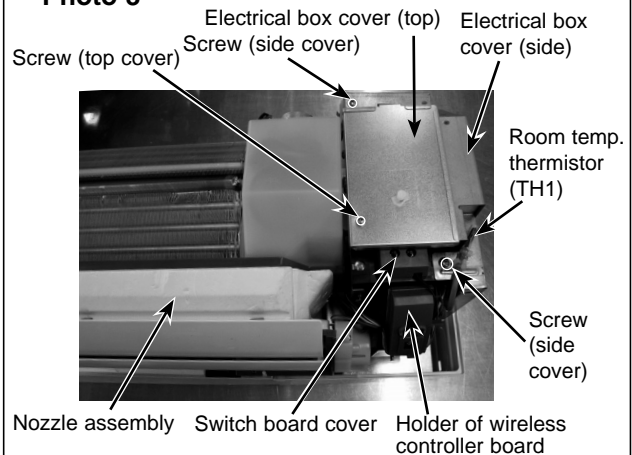

Photo 4

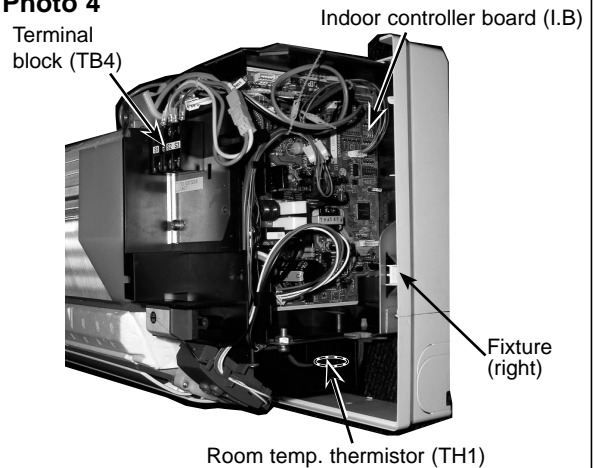

Photo 6

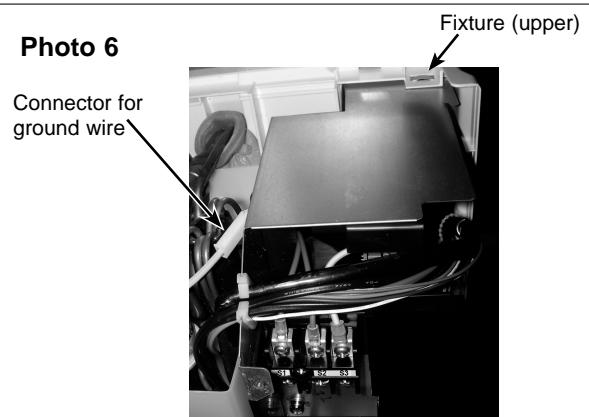
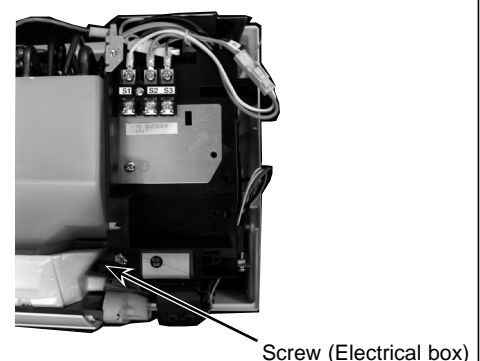
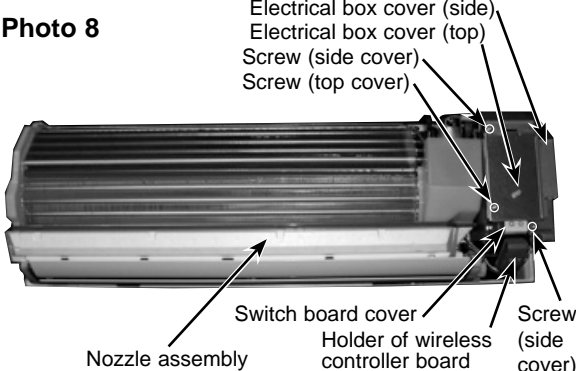
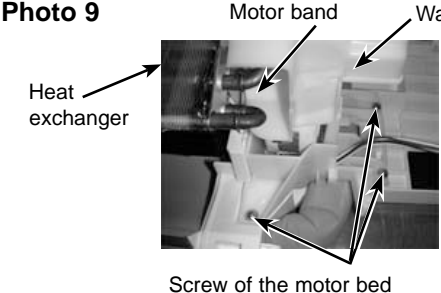
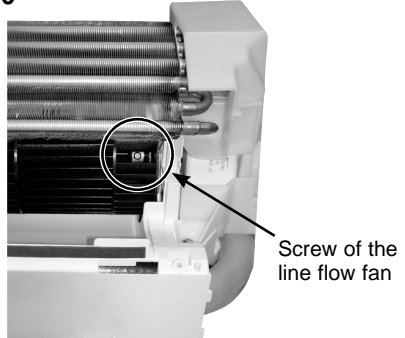
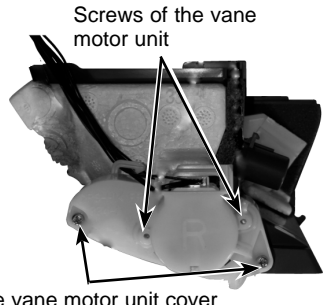
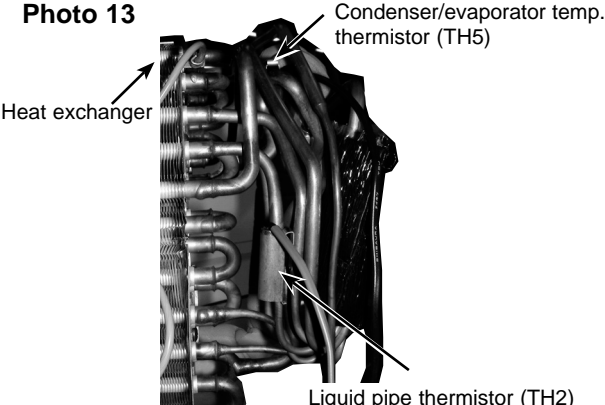

Photo 7





| OPERATION PROCEDURE | PHOTOS |
|---|---|
| <p>5. REMOVING THE NOZZLE ASSEMBLY (with VANE and VANE MOTOR) AND DRAIN HOSE</p> <ol style="list-style-type: none"> (1) Remove the front panel (Refer to 2.). (2) Remove the electrical box cover. (3) Disconnect the vane motor connector (CN151) on the indoor controller board. (4) Remove the corner box. (5) Pull the nozzle assembly and detach. (6) Push the fixture and remove the drain hose. | <p>Photo 8</p>  <p>Electrical box cover (side) Electrical box cover (top) Screw (side cover) Screw (top cover) Switch board cover Holder of wireless controller board Screw (side cover) Nozzle assembly</p> |
| <p>6. REMOVING THE INDOOR FAN MOTOR AND THE LINE FLOW FAN</p> <ol style="list-style-type: none"> (1) Remove the front panel (Refer to 2.) and the corner box at right lower side. (2) Remove the electrical box (Refer to 4.) and the nozzle assembly (Refer to 5.). (3) Remove the screws fixing the motor bed. (See Photo 9) (4) Loosen the screw fixing the line flow fan. (See Photo 10) (5) Remove the motor bed together with fan motor and motor band. (6) Release the hooks of the motor band. Remove the motor band. Pull out the indoor fan motor. (7) Remove the screws fixing the left side of the heat exchanger. (See Photo 11) (8) Lift the heat exchanger, and pull out the line flow fan to the lower-left. | <p>Photo 9</p>  <p>Heat exchanger Motor band Water cover Screw of the motor bed</p> <p>Photo 10</p>  <p>Screw of the line flow fan</p> |
| <p>7. REMOVING THE VANE MOTOR</p> <ol style="list-style-type: none"> (1) Remove the nozzle assembly. (Refer to 5.) (2) Remove the screws of the vane motor unit, and pull out the vane motor unit. (3) Remove the screws of the vane motor unit cover. (4) Remove the vane motor from the vane motor unit. (5) Disconnect the connector from the vane motor. | <p>Photo 12</p>  <p>Screws of the vane motor unit Screws of the vane motor unit cover</p> |
| <p>8. REMOVING THE LIQUID PIPE THERMISTOR AND COND/EVA TEMP. THERMISTOR</p> <ol style="list-style-type: none"> (1) Remove the front panel. (Refer to 2) (2) Remove the electrical box cover. (3) Remove the motor band. (4) Cut the wiring fixed band. (5) Remove the liquid pipe thermistor and cond/eva temp. thermistor. (6) Disconnect the connector (CN44) on the indoor controller board. | <p>Photo 13</p>  <p>Heat exchanger Condenser/evaporator temp. thermistor (TH5) Liquid pipe thermistor (TH2)</p> |

OPERATION PROCEDURE

9. REMOVING THE HEAT EXCHANGER

- (1) Remove the front panel (Refer to 2.) and the corner panel at right lower side.
- (2) Remove the electrical box (Refer to 4.) and the nozzle assembly (Refer to 5.).
- (3) Remove the motor band.
- (4) Remove the pipe thermistors (Refer to 8.).
- (5) Disconnect the connector (CN60) on the indoor controller board and the connector for ground wire. (See Photo 6)
- (6) Remove the screws fixing the left side of the heat exchanger. (See Photo 10)
- (7) Remove the heat exchanger.

PHOTOS

Photo 14

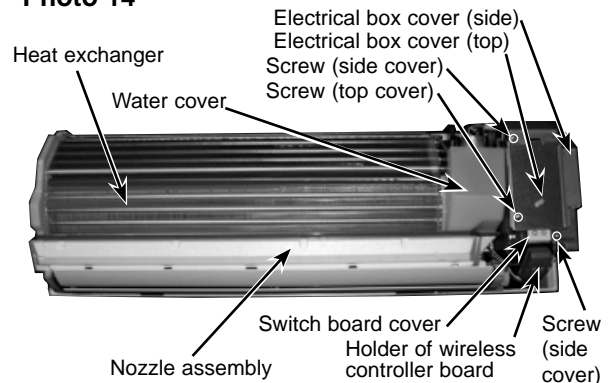

10. REMOVING THE ROOM TEMPERATURE THERMISTOR

- (1) Remove the front panel (Refer to 2.).
- (2) Remove the electrical box cover.
- (3) Remove the room temperature thermistor.
- (4) Disconnect the connector (CN20) on the indoor controller board.

NOTE: When room temp. thermistor is replaced, be sure to use service parts No. R01 N20 202.

Photo 16

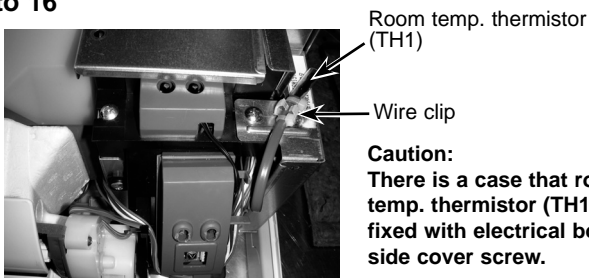
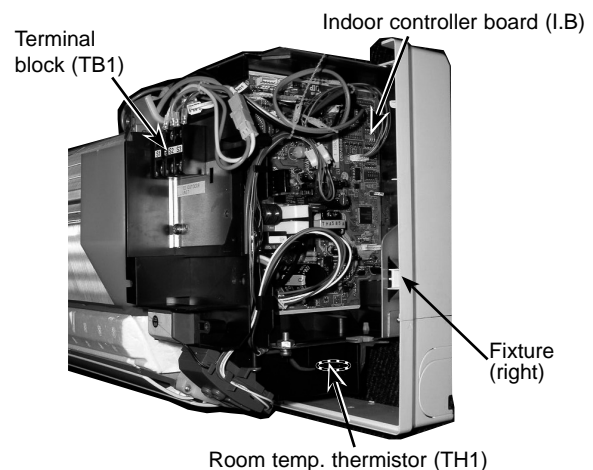

Photo 15



 **MITSUBISHI ELECTRIC CORPORATION**

HEAD OFFICE : TOKYO BLDG., 2-7-3, MARUNOUCHI, CHIYODA-KU, TOKYO 100-8310, JAPAN