

UTOPIA IVX PREMIUM / IVX STANDARD SERIES
H(V)N(P/C)(E)

Technical Catalogue

RAS-(2-6)HVNP(E)
RAS-(4-12)HNP(E)

RAS-(3-6)HVNC(E)
RAS-(4-12)HNC(E)

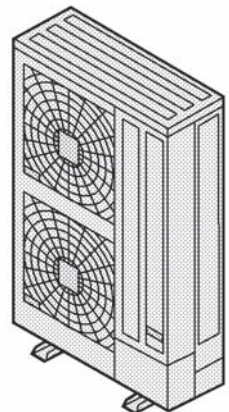
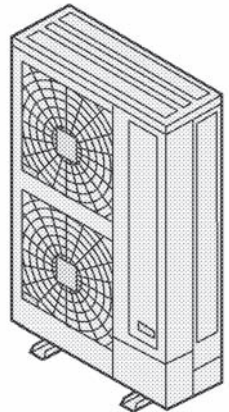
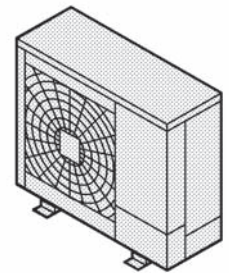

Contents

General information	1
Features and benefits	2
General data	3
Capacities and selection data	4
Acoustic characteristic curves	5
Working range	6
General dimensions	7
Refrigerant cycle	8
Piping work and refrigerant charge	9
Electrical wiring	10
Troubleshooting	11

Contents

1.	General information.....	1
1.1	General information.....	2
1.1.1	General notes.....	2
1.1.2	Introduction.....	2
1.1.3	Environment-friendly units.....	2
1.2	Safety.....	3
1.2.1	Applied symbols.....	3
1.2.2	Norms and Regulations.....	3
1.3	Product guide.....	4
1.3.1	Classification of outdoor unit models.....	4
1.3.2	Classification of indoor unit models.....	4
1.3.3	Product guide: Outdoor units.....	5
1.3.4	Outdoor unit accessory code list.....	6
1.3.5	Product guide: Indoor units & complementary systems.....	7
1.3.6	Product guide: complementary systems.....	10
2.	Features and benefits.....	13
2.1	New IVX Series.....	14
2.1.1	Main new features.....	14
2.2	Eco-Design and Seasonal Efficiency.....	20
2.2.1	Eco-Design.....	20
2.2.2	Seasonal Efficiency.....	20
2.2.3	Energy classes and Energy label.....	21
2.3	Selection benefits.....	23
2.3.1	Wide range of Outdoor Units.....	23
2.3.2	Flexible system.....	23
2.3.3	Assisted air conditioning installation design by Hi-Tool kit selection software.....	24
2.4	Installation benefits.....	25
2.4.1	Easy and flexible electrical installation.....	25
2.4.2	Easy and flexible control connection (Central Station, BMS Interface, CS-NET WEB).....	26
2.5	Start-up benefits.....	27
2.5.1	Automatic start-up test.....	27
2.5.2	Service verification.....	27
2.6	Maintenance benefits.....	29
2.6.1	Minimum maintenance.....	29
2.6.2	Easy accessibility.....	29
2.6.3	Alarm codes.....	29

3.	General data	31
3.1	General information.....	32
3.1.1	Combination with indoor units	32
3.1.2	Considerations	32
3.2	IVX Premium series.....	33
3.2.1	General specifications	33
3.2.2	Seasonal cooling/heating performance and EER/COP (2 - 4 HP)	37
3.2.3	EER/COP (5/6 HP).....	38
3.2.4	EER/COP (8-12 HP).....	38
3.3	IVX Standard series	39
3.3.1	General specifications	39
3.3.2	Seasonal cooling/heating performance and EER/COP (2 - 4 HP)	42
3.3.3	EER/COP (5/6 HP).....	42
3.3.4	EER/COP (8-12 HP).....	43
3.4	Component data	44
3.4.1	IVX Premium series.....	44
3.4.2	IVX Standard series	45
3.5	Electrical data.....	47
3.5.1	Considerations	47
3.5.2	IVX Premium series.....	47
3.5.3	IVX Standard series	47
4.	Capacities and selection data.....	49
4.1	Combinability range	50
4.2	System selection procedure.....	51
4.2.1	Selection procedure (step 1)	51
4.2.2	Selection procedure (step 2)	53
4.3	Maximum cooling capacity curve	54
4.3.1	IVX Premium series.....	54
4.3.2	IVX Standard series	58
4.4	Maximum heating capacity curve.....	62
4.4.1	IVX Premium series.....	62
4.4.2	IVX Standard series	66
4.5	Correction curve factor	70
4.5.1	Cooling	70
4.5.2	Heating	70
4.6	Piping length correction factor.....	71
4.6.1	IVX Premium series.....	71
4.6.2	IVX Standard series	74

4.7	Correction factor / ratio.....	76
4.7.1	Defrost Operation correction factor	76
4.7.2	Correction ratio due to humidity (CR).....	76
5.	Acoustic characteristic curves.....	77
5.1	Overall sound level.....	78
5.2	Sound pressure data.....	79
5.2.1	IVX Premium series.....	79
5.2.2	IVX Standard series	81
6.	Working range.....	85
6.1	Working range.....	86
6.1.1	Power supply.....	86
6.1.2	Temperature range.....	87
7.	General dimensions.....	89
7.1	Dimensions.....	90
7.1.1	IVX Premium series.....	90
7.1.2	IVX Standard series	94
7.2	Service space.....	98
7.2.1	Basic sizes	98
7.2.2	RAS-(2/2.5)HVNP / RAS-3HVNC.....	98
7.2.3	RAS-(3-12)H(V)N(P/C)(E).....	99
8.	Refrigerant cycle.....	103
8.1	General notes.....	104
8.2	IVX Premium series.....	105
8.3	IVX Standard series	108
9.	Piping work and refrigerant charge	111
9.1	Refrigerant pipe selection.....	112
9.1.1	Pipe size selection.....	112
9.1.2	Multikit or distributor selection.....	112
9.2.1	Refrigerant piping length	112
9.2.2	Piping system for header branch.....	113
9.2.3	Piping system for line branch	114
9.2.4	Combinations of piping size and piping length.....	115
9.2.5	Refrigerant piping size and multikit/distributor.....	116
9.3	Copper pipes, sizes and connection	119
9.3.1	Copper pipes and sizes.....	119

9.3.2	Pipe connection.....	120
9.3.3	Insulation.....	120
9.4	Refrigerant charge amount.....	121
9.4.1	Refrigerant charge before shipment (W0 (kg)).....	121
9.4.2	Calculation method for the additional refrigerant charge.....	121
9.5	Caution in case of refrigerant leakage.....	124
9.5.1	Maximum permitted concentration of hydrofluorocarbon (HFC).....	124
9.5.2	Calculation of refrigerant concentration.....	124
9.5.3	Countermeasure for refrigerant leakage.....	124
9.6	Compatibility with the piping of current where R22 or R407C is used.	125
9.6.1	Installation procedure for existing pipes.....	125
9.6.2	When existing Air-Conditioner is a product of another manufacturer.....	125
9.6.3	Permissible range for existing Air-Conditioning Pipes (Pipe length in the case of “without cleaning process”.....	126
9.6.4	Renewal kit selection model.....	127
10.	Electrical wiring.....	131
10.1	General information.....	132
10.1.1	General notes.....	132
10.1.2	General verifications.....	132
10.2	DIP and RSW switches settings.....	134
10.3	Common wiring.....	138
10.3.1	Electrical wiring between outdoor and indoor unit.....	138
10.3.2	Wire size.....	139
10.4	H-LINK II system.....	140
10.4.1	Features.....	140
10.4.2	Specifications.....	140
10.4.3	DIP Switch setting for 2, 3 and 4 indoor units systems.....	141
10.4.4	Examples of the system of connection between H-LINK and H-LINK II units.....	142
10.4.5	Examples of H-LINK II system.....	143
10.5	System Control.....	145
10.5.1	Individual Operation.....	145
10.5.2	Simultaneous Operation.....	146
11.	Troubleshooting.....	147
11.1	On-screen displays during abnormal operation.....	148
11.1.1	PC-ARF Troubleshooting help menu.....	148
11.2	Alarm codes.....	150

1 . General information

1

Contents

1. General information.....	1
1.1 General information.....	2
1.1.1 General notes.....	2
1.1.2 Introduction.....	2
1.1.3 Environment-friendly units.....	2
1.2 Safety.....	3
1.2.1 Applied symbols.....	3
1.2.2 Norms and Regulations.....	3
1.3 Product guide.....	4
1.3.1 Classification of outdoor unit models.....	4
1.3.2 Classification of indoor unit models.....	4
1.3.3 Product guide: Outdoor units.....	5
1.3.4 Outdoor unit accessory code list.....	6
1.3.5 Product guide: Indoor units & complementary systems.....	7
1.3.6 Product guide: complementary systems.....	10

1.1 General information

1.1.1 General notes

No part of this publication may be reproduced, copied, filed or transmitted in any shape or form without the permission of HITACHI Air Conditioning Products Europe, S.A.

Within the policy of continuous improvement of its products, HITACHI Air Conditioning Products Europe, S.A. reserves the right to make changes at any time without prior notification and without being compelled to introducing them into products subsequently sold. This document may therefore have been subject to amendments during the life of the product.

HITACHI makes every effort to offer correct, up-to-date documentation. Despite this, printing errors cannot be controlled by HITACHI and are not its responsibility.

As a result, some of the images or data used to illustrate this document may not refer to specific models. No claims will be accepted based on the data, illustrations and descriptions included in this manual.

No type of modification must be made to the equipment without prior, written authorisation from the manufacturer.

HITACHI pursues a policy of continuing improvement in design and performance of Products. The right is therefore reserved to vary specifications without notice.

HITACHI cannot anticipate every possible circumstance that might involve a potential hazard.

No part of this manual may be reproduced without written permission.

1.1.2 Introduction

Hitachi UTOPIA series is an outdoor unit series designed with the goal to cover the requirements of the split and multisplit systems, for installations where from one indoor unit (single system) to up to 8 indoor units, are connected to the same IVX Premium outdoor unit (depending on model).

New UTOPIA series consists in two different outdoor unit series: IVX Premium and IVX Standard, which compliant with the Seasonal Efficiency driven by the EU's Energy Product Directive (Eco Design Directive (EuP Lot 10)) and Seasonal Efficiency design concept in order to meet the European Directive on seasonal efficiency (Lot 6/21 coming in 2015) (depending on the model). The Seasonal Energy Efficiency Ratio (SEER) in cooling and the Seasonal Coefficient of Performance (SCOP) in heating, show an approach values to the real energy consumption.

UTOPIA series incorporate the Hitachi inverter technology, which makes possible to adapt automatically and without the user operation the capacity of the unit, so the power input, to the real demand of the installation, increasing the system efficiency to unattainable levels with other technologies. All UTOPIA units are equipped with a heat pump, resulting in an air conditioning system valid for the whole year, in which the installation of additional and specific systems a not necessary.

IVX Premium

Nominal capacity from 5 kW to 30 kW (cooling mode). Connectable indoor units up to 8 units (depending on model) and total combination power from 50% up to 120%, outdoor units from 3 to 12HP, or 90% up to 110% for 2 and 2.5 HP outdoor units.

IVX Standard

Nominal capacity from 7.1 kW to 30 kW (cooling mode). Connectable indoor units up to 4 units (3 units for 3HP model) and total combination power from 90% up to 115%, outdoor units from 4 to 12HP, or 90% up to 110% for 3HP outdoor units.

Indoor Units

One of the main merits of Hitachi units range is the combinability and flexibility of its indoor units SYSTEM FREE. This outstanding technology makes possible to use the same indoor units with both UTOPIA and SET FREE outdoor units, making easier the design, installation and control of the air conditioning installations.

1.1.3 Environment-friendly units

This range of HITACHI outdoor units uses environmentally-friendly R410A gas refrigerant, and the RoHS and Green Dot regulations are applied throughout the manufacturing and installation process to reflect HITACHI's awareness of environmental respect and commitment.

R410A is totally environmentally-friendly since it does not contain any substances that damage the ozone layer:

ODP (ozone depleting product) =0.

HITACHI's UTOPIA series are very efficient and allow significant energy savings compared with conventional systems.

This energy efficiency means less production of CO₂, which causes the greenhouse effect.



1.2 Safety

1.2.1 Applied symbols

During normal air conditioning system design work or unit installation, greater attention must be paid in certain situations requiring particular care in order to avoid damage to the unit, the installation or the building or property.

Situations that jeopardise the safety of those in the surrounding area or that put the unit itself at risk will be clearly indicated in this manual.

To indicate these situations, a series of special symbols will be used to clearly identify these situations.

Pay close attention to these symbols and to the messages following them, as your safety and that of others depends on it.

DANGER

- *The text following this symbol contains information and instructions relating directly to your safety and physical wellbeing.*
- *Not taking these instructions into account could lead to serious, very serious or even fatal injuries to you and others in the proximities of the unit.*

In the texts following the danger symbol you can also find information on safe procedures during unit installation.

CAUTION

- *The text following this symbol contains information and instructions relating directly to your safety and physical wellbeing.*
- *Not taking these instructions into account could lead to minor injuries to you and others in the proximities of the unit.*
- *Not taking these instructions into account could lead to unit damage.*

In the texts following the caution symbol you can also find information on safe procedures during unit installation.

NOTE

- *The text following this symbol contains information or instructions that may be of use or that require a more thorough explanation.*
- *Instructions regarding inspections to be made on unit parts or systems may also be included.*

1.2.2 Norms and Regulations

Following Regulation EC N° 842/2006 on Certain Fluorinated Greenhouse gases, the total amount of refrigerant charged in the unit is indicated on the specification label.

Do not vent R410A/R407C into the atmosphere. R410A & R407C are fluorinated greenhouse gases covered by the Kyoto protocol global warming potential (GWP) R410A/R407C: = 1975/1652.5.

1.3 Product guide

1.3.1 Classification of outdoor unit models

◆ IVX series

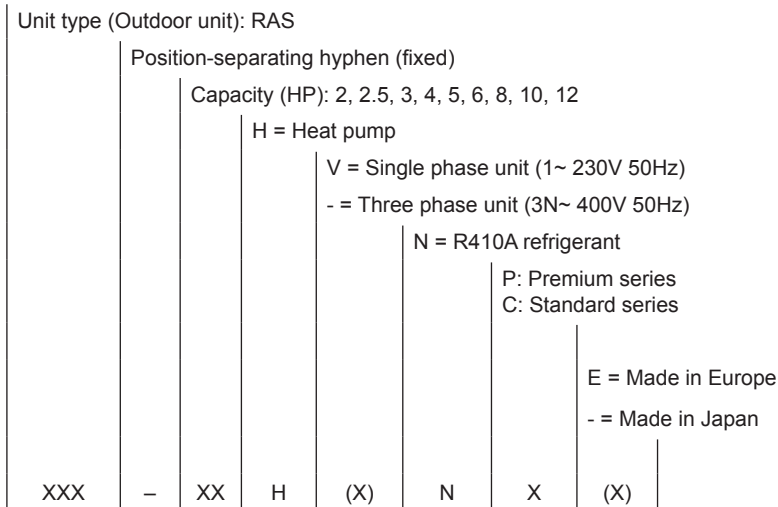

1.3.2 Classification of indoor unit models

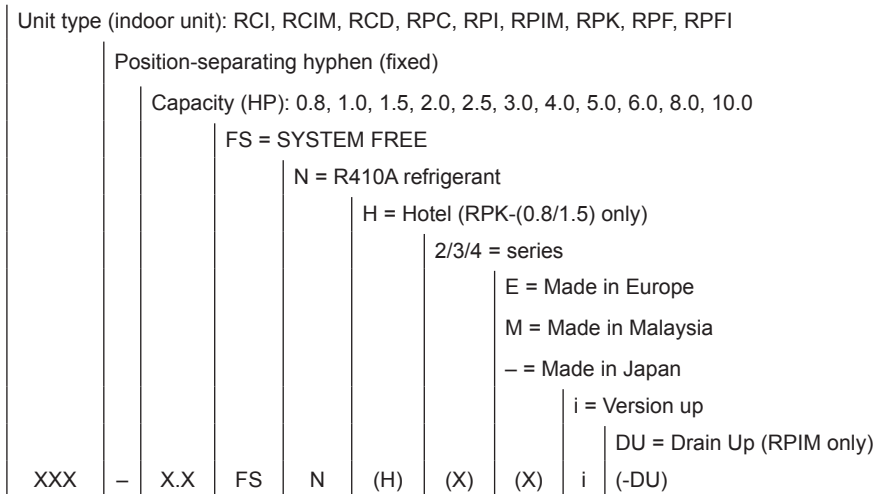





1.3.3 Product guide: Outdoor units

◆ IVX Premium

❄️ 🔥									
1~ 230V 50Hz					3N~ 400V 50Hz				
									
Unit	Code	Unit	Code	Unit	Code	Unit	Code	Unit	Code
RAS-2HVNP	60288519								
RAS-2.5HVNP	60288520								
		RAS-3HVNPE	7E304005						
				RAS-4HVNPE	7E304007	RAS-4HNPE	7E304107		
				RAS-5HVNPE	7E304008	RAS-5HNPE	7E304108		
				RAS-6HVNPE	7E304009	RAS-6HNPE	7E304109		
						RAS-8HNPE	7E310110		
						RAS-10HNPE	7E310111		
								RAS-12HNP	60278974

◆ IVX Standard

❄️ 🔥									
1~ 230V 50Hz					3N~ 400V 50Hz				
									
Unit	Code	Unit	Code	Unit	Code	Unit	Code	Unit	Code
RAS-3HVNC	60288523								
		RAS-4HVNCE	7E305027	RAS-4HNCE	7E305127				
		RAS-5HVNCE	7E305028	RAS-5HNCE	7E305128				
		RAS-6HVNCE	7E305029	RAS-6HNCE	7E305129				
						RAS-8HNCE	7E311110		
						RAS-10HNCE	7E311111		
								RAS-12HNC	60288572

1.3.4 Outdoor unit accessory code list

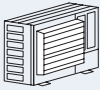
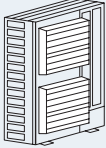
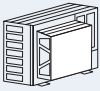
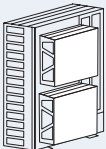
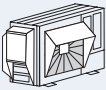
Name	Description	Code	Figure
DBS-26	Drain discharge connection	60299192	
AG-264	Air flow guide	-	
AG-335A	Air flow guide	60291431	
WSP-264	Wind guard	60291728	
WSP-335A	Wind guard	60291432	
ASG-NP80F	Snow protection hood; air outlet (Zinc plate)	-	
ASG-NP80FS2	Snow protection hood; air outlet (Stainless plate)	-	
ASG-NP335F	Snow protection hood; air outlet (Zinc plate)	60291433	
ASG-NP335FS2	Snow protection hood; air outlet (Stainless plate)	-	
ASG-NP56B	Snow protection hood; air inlet of rear side (Zinc plate)	-	
ASG-NP63BS2	Snow protection hood; air inlet of rear side (Stainless plate)	-	
ASG-NP80B	Snow protection hood; air inlet of rear side (Zinc plate)	-	
ASG-NP160BS2	Snow protection hood; air inlet of rear side (Stainless plate)	-	
ASG-NP280B	Snow protection hood; air inlet of rear side (Zinc plate)	-	
ASG-NP280BS2	Snow protection hood; air inlet of rear side (Stainless plate)	-	
ASG-NP335B	Snow protection hood; air inlet of rear side (Zinc plate)	60291434	
ASG-NP335BS2	Snow protection hood; air inlet of rear side (Stainless plate)	-	
ASG-NP56L	Snow protection hood; air inlet of left side (Zinc plate)	-	
ASG-NP63LS2	Snow protection hood; air inlet of left side (Stainless plate)	-	
ASG-NP80L	Snow protection hood; air inlet of left side (Zinc plate)	-	
ASG-NP160LS2	Snow protection hood; air inlet of left side (Stainless plate)	-	
ASG-NP280L	Snow protection hood; air inlet of left side (Zinc plate)	-	
ASG-NP280LS2	Snow protection hood; air inlet of left side (Stainless plate)	-	
ASG-NP335L	Snow protection hood; air inlet of left side (Zinc plate)	60291435	
ASG-NP335LS2	Snow protection hood; air inlet of left side (Stainless plate)	-	









NOTE

HITACHI has a range of accessories and remote control systems that can be used with the UTOPIA outdoor units. Please, refer to the Controls Technical Catalogue.

1.3.5 Product guide: Indoor units & complementary systems

◆ RCI and RCIM indoor units

FSN(2/3)(E)(i) indoor units					
RCI			RCIM		
					
4-way cassette				4-way cassette (compact)	
Unit	Code	Unit	Code	Unit	Code
RCI-1.0FSN3Ei	7E403014	RCI-1.0FSN3	60278119	RCIM-0.8FSN2	60278010
RCI-1.5FSN3Ei	7E403015	RCI-1.5FSN3	60278120	RCIM-1.0FSN2	60278011
RCI-2.0FSN3Ei	7E403016	RCI-2.0FSN3	60278121	RCIM-1.5FSN2	60278013
RCI-2.5FSN3Ei	7E403017	RCI-2.5FSN3	60278122	RCIM-2.0FSN2 (*)	60278014
RCI-3.0FSN3Ei	7E403018	RCI-3.0FSN3	60278123		
RCI-4.0FSN3Ei	7E403020	RCI-4.0FSN3	60278124		
RCI-5.0FSN3Ei	7E403021	RCI-5.0FSN3	60278125		
RCI-6.0FSN3Ei	7E403022	RCI-6.0FSN3	60278126		



Panels (Optional)					
					
P-N23NA	70531000	P-AP160NA1	60297215	P-N23WAM	60197160
		P-AP160NAE (With motion sensor)	60297217		



NOTE

- The RCI and RCIM models must be used in combination with the panels indicated above.
- (*): 2 indoor units combinations with IVX Premium/Standard series not allowed

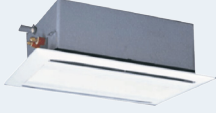
◆ **RCD and RPC indoor units**

FSN2(E) indoor units					
RCD				RPC	
					
2-way cassette				Ceiling type	
Unit	Code			Unit	Code
RCD-1.0FSN2	60278029				
RCD-1.5FSN2	60278030				
RCD-2.0FSN2	60278031			RPC-2.0FSN2E	7E440003
RCD-2.5FSN2	60278032			RPC-2.5FSN2E	7E440004
RCD-3.0FSN2	60278033			RPC-3.0FSN2E	7E440005
		RCD-4.0FSN2	60278034	RPC-4.0FSN2E	7E440007
		RCD-5.0FSN2	60278035	RPC-5.0FSN2E	7E440008
				RPC-6.0FSN2E	7E440009



Panels (Optional)			
			
P-N23DNA	60297211	P-N46DNA	60297212



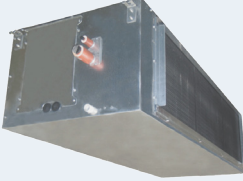

NOTE

- The RCD models must be used in combination with the panels indicated above.

◆ **RPC, RPI and RPIM indoor units**

FSN(3/4)E indoor units					
RPI			RPIM		
					
Indoor ducted unit					
Unit	Code	Unit	Code	Unit	Code
RPI-0.8FSN4E	7E424013			RPIM-0.8FSN4E	7E430013
				RPIM-0.8FSN4E-DU	7E431013
RPI-1.0FSN4E	7E424014			RPIM-1.0FSN4E	7E430014
				RPIM-1.0FSN4E-DU	7E431014
RPI-1.5FSN4E	7E424015			RPIM-1.5FSN4E	7E430015
				RPIM-1.5FSN4E-DU	7E431015
RPI-2.0FSN4E	7E424016				
RPI-2.5FSN4E	7E424017				
RPI-3.0FSN4E	7E424018				
RPI-4.0FSN4E	7E424020				
RPI-5.0FSN4E	7E424021				
RPI-6.0FSN4E	7E424022				
		RPI-8.0FSN3E	7E424010		
		RPI-10.0FSN3E	7E424011		

◆ **RPK, RPF and RPFI indoor units**

FSN(H)(2/3)(E/M) indoor units					
RPK		RPF		RPFI	
					
Wall type		Floor type		Floor concealed type	
Unit	Code	Unit	Code	Unit	Code
RPK-0.8FSN3M	60278146				
RPK-0.8FSNH3M	60278154				
RPK-1.0FSN3M	60278147	RPF-1.0FSN2E	7E450001	RPFI-1.0FSN2E	7E460001
RPK-1.0FSNH3M	60278155				
RPK-1.5FSN3M	60278148	RPF-1.5FSN2E	7E450002	RPFI-1.5FSN2E	7E460002
RPK-1.5FSNH3M	60278156				
RPK-2.0FSN3M	60278149	RPF-2.0FSN2E (*)	7E450003	RPFI-2.0FSN2E	7E460003
RPK-2.5FSN3M	60278150	RPF-2.5FSN2E (*)	7E450004	RPFI-2.5FSN2E	7E460004
RPK-3.0FSN3M	60278151				
RPK-4.0FSN3M	60278152				
EV-1.5N1 ⁽¹⁾	60291791				



NOTE

- (*) : 2 indoor unit combinations with IVX Premium/Standard series not allowed
- (1) For RPK-(0.8-1.5)FSNH3M models only.

1.3.6 Product guide: complementary systems

◆ **KPI energy / heat recovery unit**

NEW

Complementary systems					
KPI					
					
Energy recovery		Heat recovery		Active (Energy Recovery+DX section)	
Unit	Code	Unit	Code	Unit	Code
KPI-252E3E	70602000				
KPI-502E3E	70602001	KPI-502H3E	70602101	KPI-502X3E	70602201
KPI-802E3E	70602002	KPI-802H3E	70602102	KPI-802X3E	70602202
KPI-1002E3E	70602003	KPI-1002H3E	70602103	KPI-1002X3E	70602203
KPI-1502E3E	70602004	KPI-1502H3E	70602104		
KPI-2002E3E	70602005	KPI-2002H3E	70602105		

◆ **DX-Interface**

NEW

Control box



Expansion valve box



1

DX-Interface	
Model	Code
EXV-2.0E1	7E610900
EXV-2.5E1	7E610901
EXV-3.0E1	7E610902
EXV-4.0E1	7E610903
EXV-5.0E1	7E610904
EXV-6.0E1	7E610905
EXV-8.0E1	7E610906
EXV-10.0E1	7E610907

2 . Features and benefits

2

Contents

2.	Features and benefits	13
2.1	New IVX Series	14
2.1.1	Main new features	14
2.2	Eco-Desing and Seasonal Efficiency	20
2.2.1	Eco-Design	20
2.2.2	Seasonal Efficiency	20
2.2.3	Energy classes and Energy label	21
2.3	Selection benefits	23
2.3.1	Wide range of Outdoor Units	23
2.3.2	Flexible system	23
2.3.3	Assisted air conditioning installation design by Hi-Tool kit selection software	24
2.4	Installation benefits	25
2.4.1	Easy and flexible electrical installation	25
2.4.2	Easy and flexible control connection (Central Station, BMS Interface, CS-NET WEB)	26
2.5	Start-up benefits	27
2.5.1	Automatic start-up test	27
2.5.2	Service verification	27
2.6	Maintenance benefits	29
2.6.1	Minimum maintenance	29
2.6.2	Easy accessibility	29
2.6.3	Alarm codes	29

2.1 New IVX Series

Hitachi is pleased to introduce a new product line of IVX Outdoor Units:

IVX Premium	IVX Standard
<ol style="list-style-type: none"> 1 Improved the connected capacity ratio of Indoor Units from 50 % to 120% of Outdoor Unit capacity (depending on the models). 2 Increased the number of connectable Indoor Units up to 8 units (depending on the models). 3 Compact sizes (3, 8 and 10 HP). 4 Compliant with new Eco Design Directive (EuP Lot 10) and Seasonal Efficiency design concept in order to meet the European Directive on seasonal efficiency (Lot 6/21 coming in 2015) (depending on the models) 5 IU individual operation (factory setting). 6 Minimum connectable capacity of IU can be as low as 0.8 HP. 7 Improved energy performance by new compressor and new cycle design. 8 Compatibility with the piping of current installations where R22 or R407C are used (see chapter 9.6). 	<ol style="list-style-type: none"> 1 Increased the connected capacity ratio of Indoor Units from 90 % to 115% (depending on the models). 2 Increased the number of connectable Indoor Units up to 4 units (depending on the models). 3 Compact sizes up to 10HP. 4 Seasonal Efficiency design concept in order to meet the European Directive on seasonal efficiency (Lot 6/21 coming in 2015) (depending on the models). 5 IU Individual operation (factory setting). 6 Minimum connectable capacity of IU can be as low as 0.8 HP (depending on the models). 7 Improved energy performance by new compressor and new cycle design. 8 Compatibility with the piping of current installations where R22 or R407C are used (see chapter 9.6).

2.1.1 Main new features

Achievements of these new two series:

◆ Energy-Saving

- a) High energy-saving is realized by the improvement of intermediate capacity for the new compressors.
- b) Heat exchanger features slitless-type fins to improve the heating performance.
- c) The electrical power saving reversing valve is adopted.
- d) Improvement of Energy-Saving through the new Indoor Unit High Efficiency range and new Remote Controller.

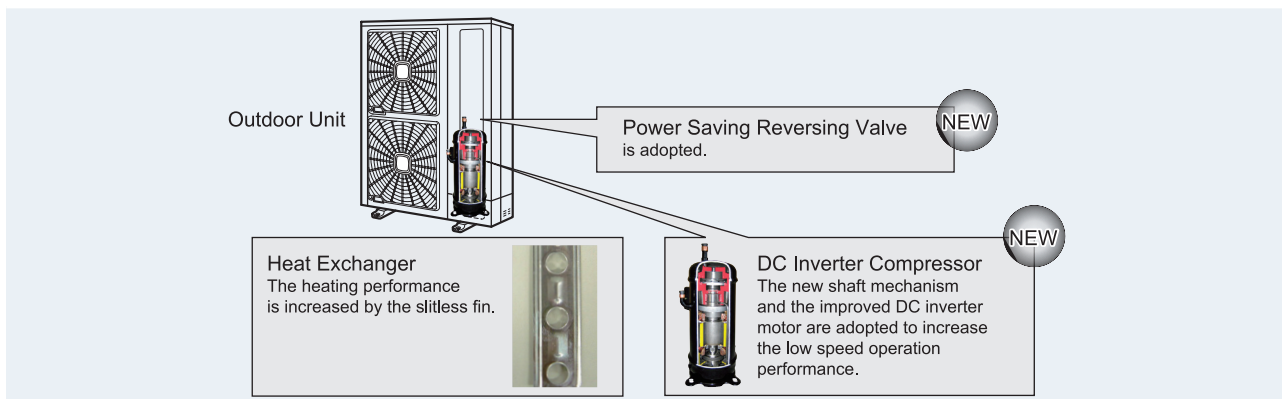

Improvement of Energy-Saving through the new Indoor Unit and Remote Controller

New RCI-(1.0-6.0)FSN3 - 4-way cassette and two optional air panels offer the following benefits:

Benefits	Outline
Improvement of Energy Saving (1) The high performance heat exchanger, the highly efficient turbo fan and the new DC drain pump are adopted. (2) Energy saving is improved by the air panel with motion sensor.	Improvement of energy saving by newly developed heat exchanger and turbo fan, and by adoption of motion sensor.
Adoption of New Structure Silky Flow Louver	Attenuation of the discomfort that might be caused by temperature irregularity and cold draft.
Flexibility of Installation to High Ceiling	Addition of air flow volume "HIGH H", which is larger than "HIGH".
Drain Pan: Adoption of New Antibacterial Agent and Larger Diameter of Drain Plug	Inhibition of slime generation, and improvement of maintainability.

i NOTE

HITACHI recommends PC-ARF remote control (optional) in order to obtain the maximum RCI-(1.0-6.0)FSN3 performance

Adoption of High Performance Heat Exchanger, High Efficient Turbo Fan and New DC Drain Pump

The adoption of the high performance heat exchanger with small diameter pipe (φ5mm), the turbo fan with 3D twisted blade and the electrical power saving drain pump with DC motor allows high energy-saving operation.

Improvement of Energy-Saving Operation by Adopting Air Panel with Motion Sensor

- Adopting Motion Sensor Function
 - ◆ The motion sensor function can adjust the setting temperature according to the human activity, and it controls the air flow volume and the air flow direction.
 - ◆ Energy-saving is improved by combining the motion sensor function and the individual operating function, compared with the standard operation.

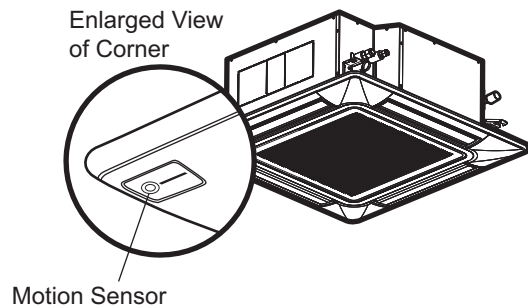

The air conditioning capacity is regulated automatically depending on the situation and detecting the amount of human activity through the motion sensor located on the corner of the air panel.

Energy-saving can be improved even more with the individual operation function. In addition, the operation can be stopped automatically if absence continues for more than 30 minutes.

The motion sensor allows maintaining the comfortable indoor environment and suppressing the unnecessary operation.

The motion sensor control adjusts automatically the following items depending on the situation:

- Setting temperature: is adjusted by 1°C or 2°C for energy saving
- Air flow volume: is adjusted to one volume lower or to "Slo" (except during the dry operation).
- Air flow direction: is adjusted to horizontal.

Effect of Energy-Saving by Motion Sensor

In the case of motion sensor being set as "ON" by the remote control switch and comparing with the temperature setting before adjusting the operation as shown below (at cooling mode):

- The power consumption can be reduced max 7% by 1°C increase adjustment.
- The power consumption can be reduced max 14% by 2°C increase adjustment.

◆ **Comfortability and Installability**

The individual operating function is adopted. In addition, the number of connectable indoor units is increased.

Reduction of Local Temperature Irregularity and Creation of Comfortable Room Conditions

The individual thermo-ON/OFF control is available by one remote control switch to control multiple indoor units. The air conditioning operation allows to control the room temperature as appropriate, according to the different air-conditioning load present for instance in the middle of a room and at its perimeter zone. As a result, this function provides comfortable air conditioning and energy-saving.

- Interior Zone: a zone not affected by the insolation or air outside
- Perimeter Zone: a zone affected by the insolation or air outside

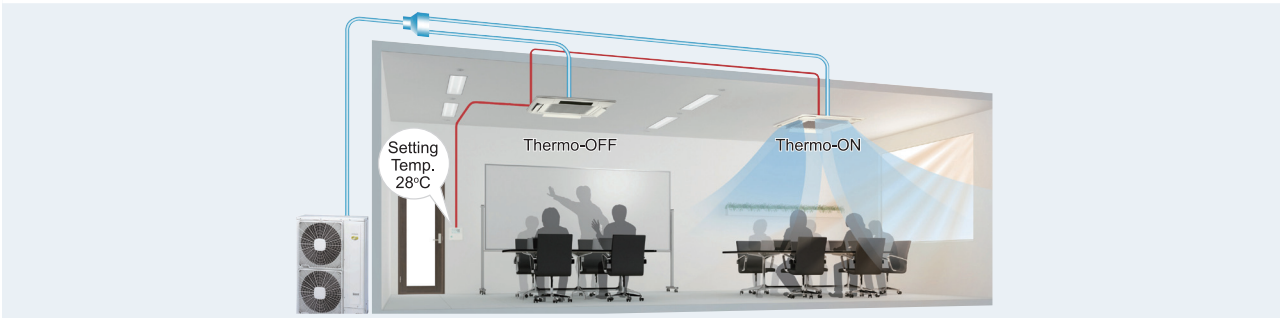

Easy Rearrangement

Multiple indoor units can be installed and operated individually even if rooms are partitioned. The individual operation can be controlled for each room by connecting the remote control switch to each indoor unit. The indoor unit can be operated only for a room where a person is, which brings energy-saving and flexible for rearrange by partitions.

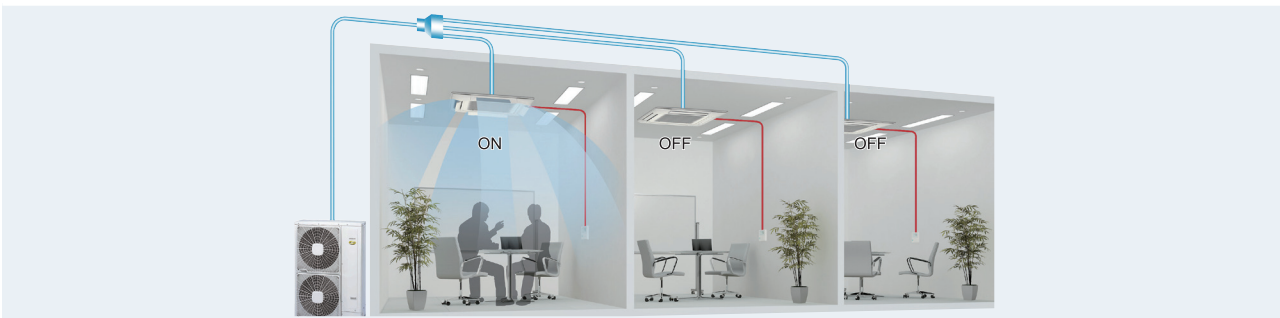

Easy Installation Work

Multiple indoor units can be connected to one outdoor unit. As a result, it makes the piping and wiring work easy so as to arrange only one refrigerant system. The installation work is facilitated and with a shorter schedule in comparison with the single type which requires an outdoor unit for each indoor unit.

Easy and shortened installation schedule are realized because four indoor units can be connected to one refrigerant cycle.

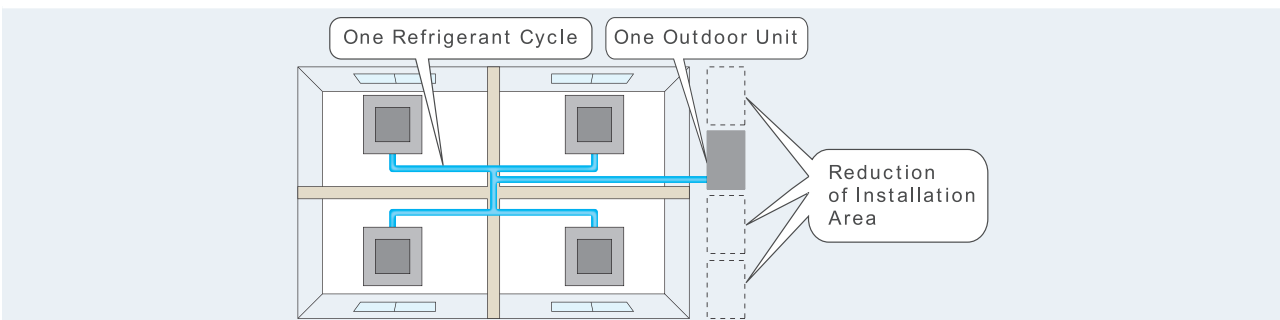

◆ **Improvement of Comfortability**

Part of the discharge gas is bypassed to the heat exchanger, making use of the surplus capacity of the outdoor unit when decreasing the thermal load of indoor units. As a result, temperature increase of the heat exchanger prevents appearance of frost. The comfortable air conditioning is continuously available by decreasing the defrosting operation frequency.

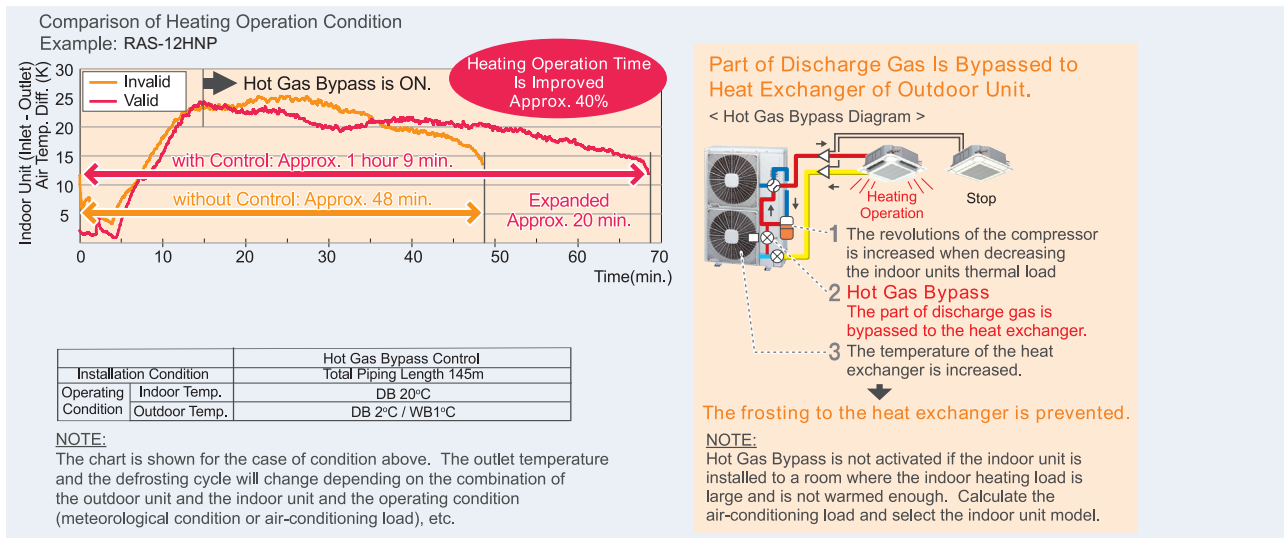

◆ **Improvement of Heating Performance by Slitless Fin**

The slitless fin is adopted for the heat exchanger. As a result, the frosting is prevented by the surface of the slitless fin and the heating performance is improved under low temperature conditions.

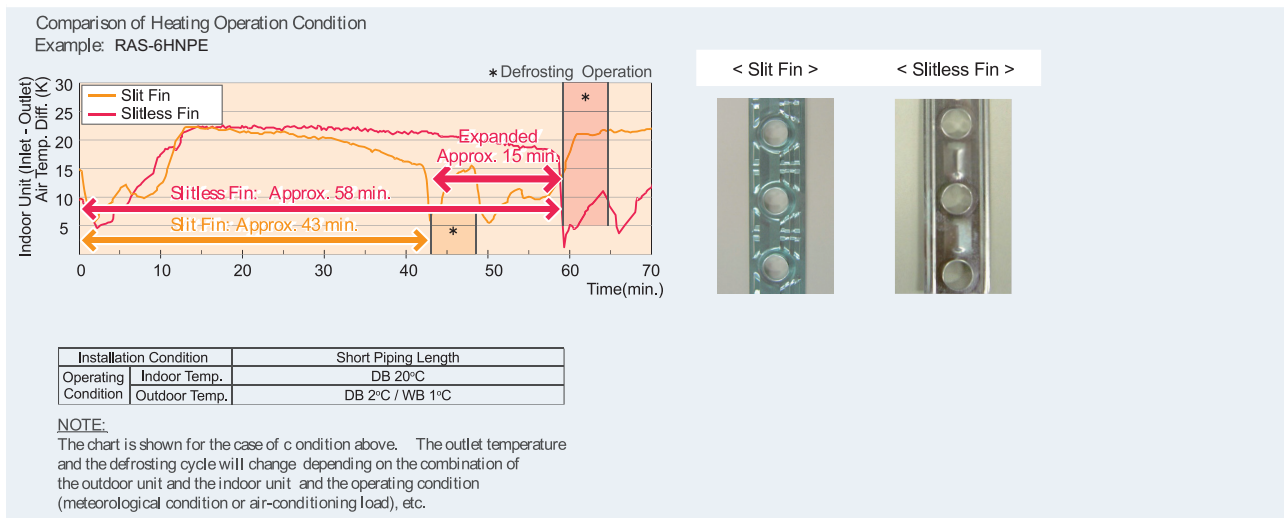

◆ **Decreasing Defrosting Operation Time and Extend Heating Operation by Control depending on Amount of Frosting**

The amount of frosting can be estimated by last defrosting time. If the amount of frosting is less than the last time, the heating operation until the defrosting operation is extended automatically. As a result, an unnecessary defrosting operation is decreased and the continuous heating operation is available.

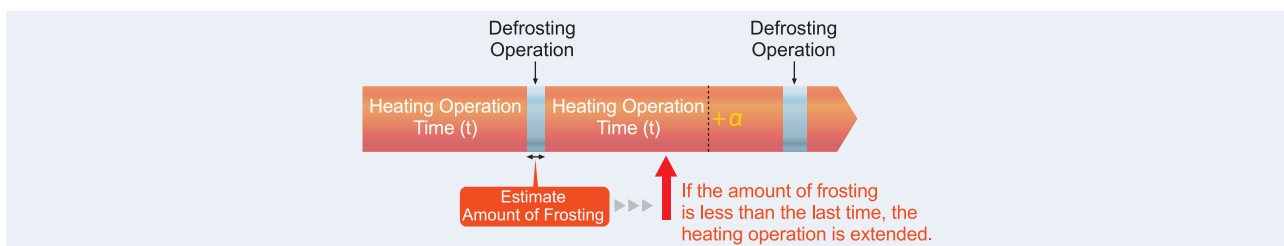

◆ **Compact and lightweight design**

- The new 3 HP IVX Standard is designed in a more compact and lightweight fashion in comparison with the current 3 HP IVX model.

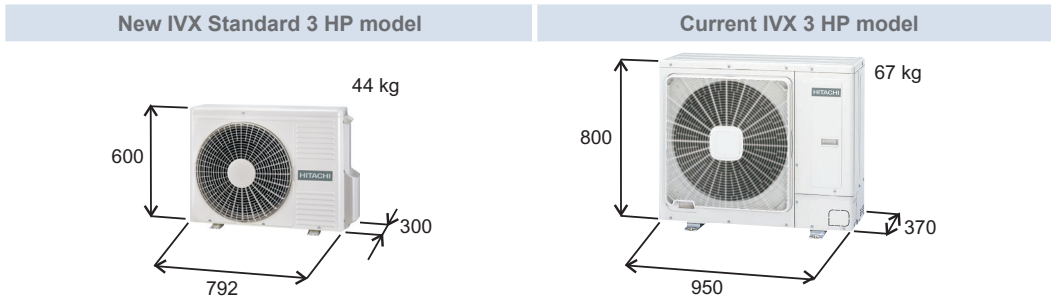

- More compact and lightweight design for the new 8 and 10 HP.

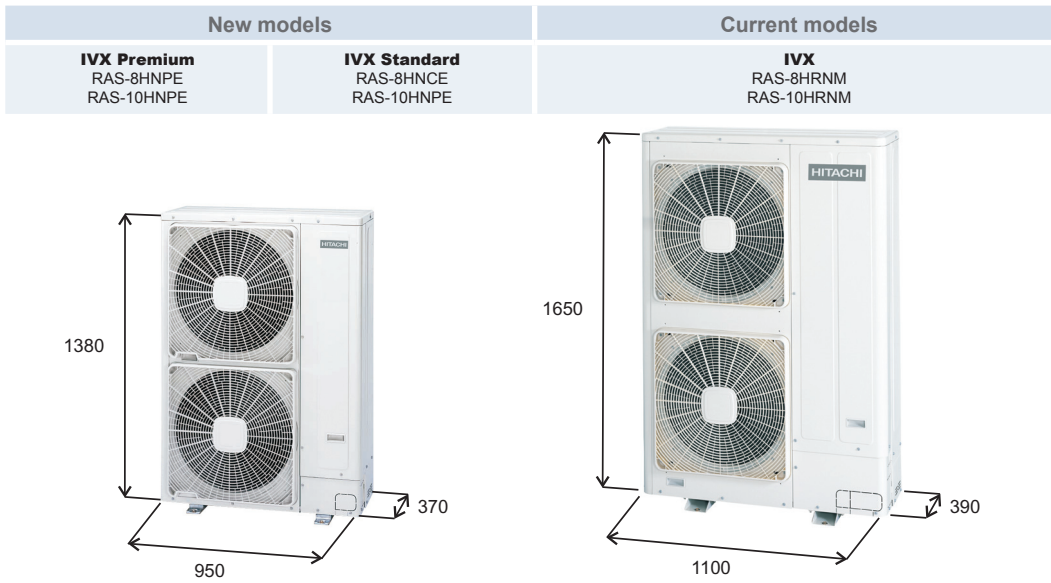

Example of weight improvement:

New IVX Premium/Standard = 136 - 138 kg
 Current IVX model = ~ 170 kg

* New 12 HP keep the same external dimensions as current model.

◆ **Enhanced combination of Outdoor Units and Indoor Units**

The number of the Indoor Units connectable to one Outdoor Unit is increased.

HP	Maximum connectable Indoor Units	
	New IVX Premium Series	Current Series
2	2	1
2.5	2	1
3	3	2
4	5	4
5	6	4
6	6	4
8	8	4
10	8	4
12	8	4

i **NOTE**

Please, check the chapter about combinability restrictions

◆ Compatibility with the piping of current installations where R22 or R407C are used.

The new IVX Premium and IVX Standard are compatible with those installations that have been operating with R22 or R407C. This allows installing the IVX Premium/Standard Outdoor Units, which operate with R410A, without having to change piping installation, even when the thickness is less than the R410A piping specifications.

This option is easily configured through the DSW2, by setting pin 4 ON. With this setting, the control system adjusts the pressure in order to avoid damage to the existing pipe for R22, in case that its thickness is less than the R410A piping specifications. Otherwise, no settings are necessary (factory setting DSW2 pin 4 OFF)

Before applying this option, it is important to have special care with preliminary operations that need to be performed on the installation (cleaning pipes, changing filters, vacuum, etc.) and restrictions (pipe lengths, etc.).

It is important not to disregard the previous operations and the established restrictions; otherwise, serious damage can be caused to the equipment and installation.

2.2 Eco-Design and Seasonal Efficiency

To respond to the European Environmental Objectives of the 3 x 20 (-20% energy consumption, -20% CO₂ emission, +20% renewable energy) within 2020, Europe revised the original Ecodesign Directive (Directive 2005/32/CE) and enlarged the applications covered. Initially the scope of Eco-Design was products using energy (E.u.P.). From now on, the scope of Eco-Design will be all products related to energy reduction (ex : air conditioning, windows...) and is called ErP (Energy related Products).

2.2.1 Eco-Design

The **Eco-Design** of Energy-related products (ErP) Directive provides consistent EU-wide rules for improving the environmental performance of energy related products (ErP) by requiring integration of eco considerations at the outset of product design – ensuring reduced energy consumption to benefit both businesses and consumers. It implies a consideration of the environmental aspect of any products or services developed. This approach consists of qualifying ‘CO₂ emission’ and ‘energy consumption’ during the whole life of the product (from design to the end life, including transport).

Eco-Design analyses highlighted the fact that the major environmental impact is related to the “usage period” of the above products. For this reason, ErP fixes minimum performance levels to allow products coming in the European market. Simultaneously, ErP fixes technical communication contents to end user through a label (data on performance, sound level) in order to help them to make their choice.

ErP will be applied to all air conditioning and heating equipments, whatever the type (air/air, air/water, water/water, boilers...), the capacity, the usage (heating, cooling, SHW) is, through different “Lots” and at different application frameworks. The first one, coming into application on 1st January 2013, is “Lot 10”. It does concern all air conditioning systems (air/air), with a capacity lower than 12kw, operating in heating and/or cooling mode.

These regulations include air conditioning products, which are a key source of energy consumption in buildings, and require all manufacturers to calculate energy usage in a more realistic way, moving from nominal to seasonal, creating a more accurate calculation and representation of products in the market.

3 Key issues in terms of compliance are described in Directive 2010/30/UE N°626/2011 dated from 4th May 2011 and Directive 2009/125/EC N°206/2012 dated from 6th March 2012.

- (a) Fixing a minimum level of performance in heating and cooling mode
- (b) Fixing a maximum sound power level for indoor and outdoor units
- (c) Fixing communication of above characteristics to end users through labelling

Hitachi has always engineered the most environmentally-friendly heating and cooling products from its factories, and is proud to launch a complete range of fully ErP-compliant air conditioning products. Where product ranges and models fall outside the scope of the ErP directive (<12kW), there are a series of enhancements for RAC; in particular IVX Premium and IVX Standard Series, which already are market leaders in Japan’s Annual Performance Factor (APF) for seasonal efficiency.

2.2.2 Seasonal Efficiency

Seasonal Efficiency has been developed in the Eco Design Directive (EU’s Energy Related Products Directive), which specifies the minimum requirements that manufacturers must integrate into their energy using products.

Target will rely on a seasonal performance of the equipment called SCOP (heating mode) and SEER (cooling mode) for an average European climate. This performance value will replace historical nominal values of COP and EER.

The new calculation uses several rating temperatures for cooling and heating, and integrates partial capacity operation in the calculation. Since most systems operate most of the time under a partial load, the new methodology gives a better indication of expected real-life performance. The new seasonal efficiency calculation will also take into consideration the power consumed by devices in auxiliary modes like standby mode.

Seasonal Energy Efficiency Ratio (SEER) in cooling and the **Seasonal Coefficient of Performance (SCOP)** in heating give a more accurate estimation of the real performance of the equipment during the whole period of usage, all while considering:

- Several points of measure (In cooling mode: an outside temperature of 20 °C, 25 °C, 30 °C and 35 °C; in heating mode: an outside temperature of +12 °C, +7 °C, +2 °C, and -7 °C.
- Different compressor speeds (full load and partial load), Auxiliary consumption (crankcase heaters, thermostat off mode, OFF mode...)

- Conditions of temperature (number of hours per outdoor temperature) for an identified climate (average climate for ErP compliance)
- Building heat load (called Pdesign)

HITACHI, in compliance with the Eco Design Directive, has developed the new outdoor units: UTOPIA IVX Premium and IVX Standard series, whose high efficiency level (including SEER and SCOP values) is properly informed to our customers to allow for an easy selection.

IVX Premium and IVX Standard Series offer high seasonal efficiencies, as well as complete flexibility, with all outdoor units from both ranges being fully compatible with the System Free range of indoor units. Hitachi's IVX technology has all the benefits of VRF, including individual control of each indoor unit with an increased number of indoor unit combinations in addition to delivering excellent part-load efficiency.

With cooling capacities and heating capacities from 2HP to 12HP, a maximum of 8 indoor units are connectable to a single outdoor unit, with individual control and efficiencies achieved as high as A++/A+ (depending on model/combinations).

2.2.3 Energy classes and Energy label

The **energy efficiency classes** from A+++ to D are introduced based on SCOP and SEER values: The scale for energy labelling will be:

A+++	SEER ≥ 8,50	SCOP ≥ 5,10
A++	6,10 ≤ SEER < 8,50	4,60 ≤ SCOP < 5,10
A+	5,60 ≤ SEER < 6,10	4,00 ≤ SCOP < 4,60
A	5,10 ≤ SEER < 5,60	3,40 ≤ SCOP < 4,00
B	4,60 ≤ SEER < 5,10	3,10 ≤ SCOP < 3,40
C	4,10 ≤ SEER < 4,60	2,80 ≤ SCOP < 3,10
D	3,60 ≤ SEER < 4,10	2,50 ≤ SCOP < 2,80
E	3,10 ≤ SEER < 3,60	2,20 ≤ SCOP < 2,50
F	2,60 ≤ SEER < 3,10	1,90 ≤ SCOP < 2,20
G	SEER < 2,60	SCOP < 1,90

The agenda of minimum SCOP/SEER for compliance is:

	SEER	SCOP
2013	3.60 (D)	3.40 (A)
2014	4.30 (C)	3.80 (A)
2015	A+	A+

The **Energy label** is the regulation compliant way of displaying product efficiency and sound level to any point of sales. This label displays 3 European climates: average climate (green), cold climate (blue), hot climate (orange). Regulation requirement is to display any information related to performances on average climate.

Climate used on ErP	Temperature used for product selection
Average	-10°C
Cold	-22°C
Hot	+2

Enforcement date is January 1st, 2013 and the energy label will be introduced in four versions. The design of the four labels will be similar, with the exception that the labelling scale for the minimum level of performance in heating and cooling mode and the limit of maximum sound power level for indoor and outdoor units will be adjusted every other two years.

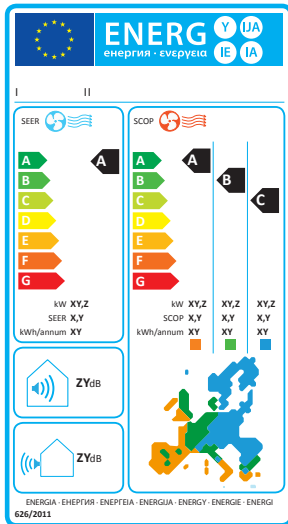

Mandatory from 2013

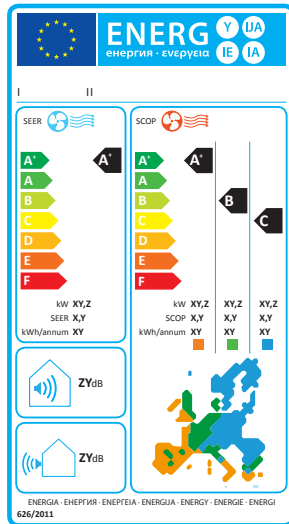

Mandatory from 2015

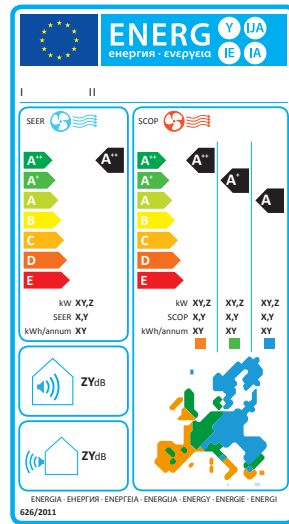

Mandatory from 2017

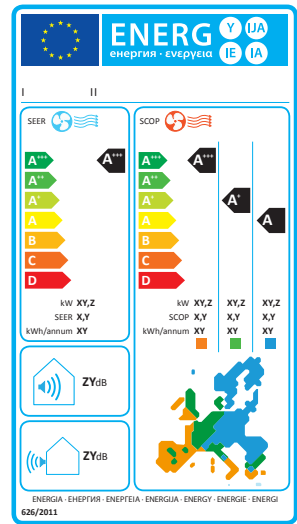

Mandatory from 2019

This new energy efficiency label for air conditioners up to 12 kW is supplied together with HITACHI IVX Premium and IVX Standard units in order to facilitate our customers their decision when purchasing. Below there is a description of each information that will be found in the energy label.

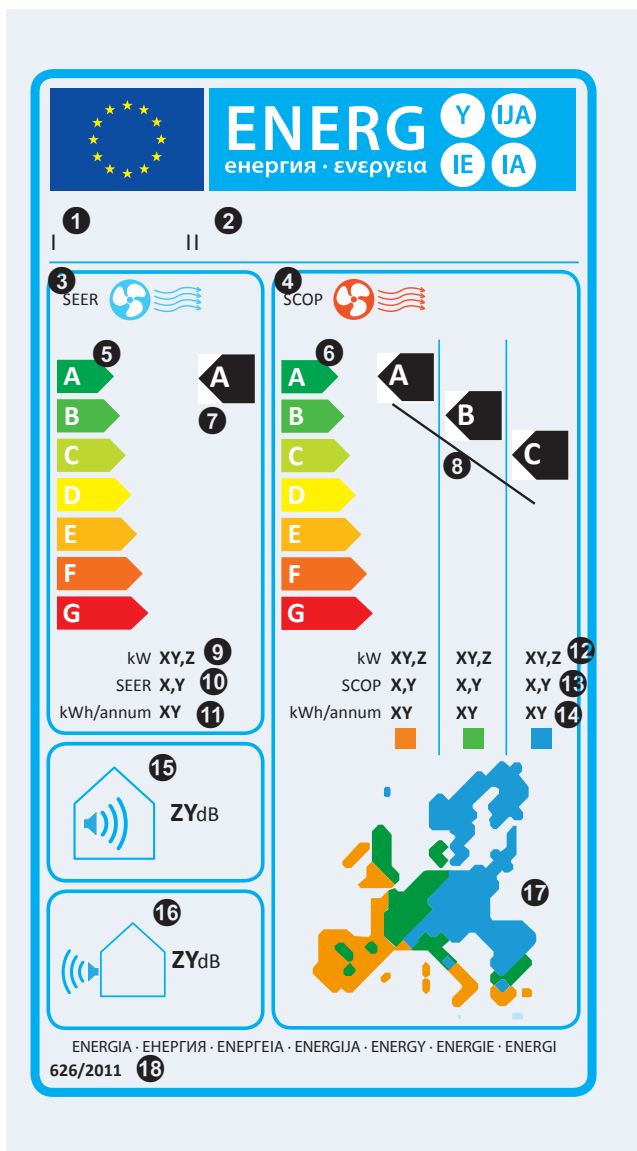

- 1 Manufacturer
- 2 Unit name
- 3 SEER (Seasonal Energy Efficiency) value in cooling mode
- 4 SCOP (Seasonal Coefficient of performance) value in heating mode
- 5 Energy efficiency classes SEER in cooling mode
- 6 Energy efficiency classes SCOP in heating mode
- 7 Energy efficiency class in cooling of the unit
- 8 Energy efficiency class in heating of the unit (the indication for the unit model is made for all three climate zones)
- 9 Nominal capacity in cooling mode
- 10 SEER value
- 11 Annual power consumption for cooling
- 12 Nominal capacity in the heating mode
- 13 SCOP value
- 14 Annual power consumption for heating
- 15 Operating noise for indoors (1)
- 16 Operating noise for outdoors (1)
- Climate zones:
- 17 Warm zone (Athens) (Orange)
Moderate zone (Strasbourg) (Green)
Cold zone (Helsinki) (Blue)
- 18 Time reference

(1) Maximally admissible			
Cooling capacity ≤ 6 kW		Cooling capacity > 6 kW ≤ 12 kW	
Indoor unit	Outdoor unit	Indoor unit	Outdoor unit
60 dB(A)	65 dB(A)	65 dB(A)	70 dB(A)

2.3 Selection benefits

2.3.1 Wide range of Outdoor Units

UTOPIA IVX outdoor unit series allows a wide range of units from 2HP to 12HP to be selected in single or three phase combinations, depending on the series and models.

		2	2.5	3	4	5	6	8	10	12
IVX Premium series	1~ 230V	●	●	●	●	●	●			
	3N~ 400V				●	●	●	●	●	●
IVX Standard series	1~ 230V			●	●	●	●			
	3N~ 400V				●	●	●	●	●	●

2.3.2 Flexible system

◆ **Improved combinability**

◆ **IVX Premium series**

	❄️🔥					
	Outdoor unit model					
	2 HP (**)	2.5 HP (***)	3 HP	4 HP	5 HP	6 HP
Maximum number of connected Indoor Units	2		3	5	6	
Connected capacity ratio of Indoor Unit % (number of connected Indoor Units)	90-110% (1 unit)		50-120% (≤ 2 units)		50-120% (≤ 4 units)	
	90-100% (2 units) (*)		50-100% (3 units) (*)	50-100% (5 units) (*)	50-100% (5 or 6 units) (*)	
Minimum capacity of Indoor Units (HP)	0.8					

	❄️🔥		
	Outdoor unit model		
	8 HP	10 HP	12 HP
Maximum number of connected Indoor Units	8		
Connected capacity ratio of Indoor Unit % (number of connected Indoor Units)	50-120% (≤ 4 units)		
	50-100% (5, 6, 7 or 8 units) (*)		
Minimum capacity of Indoor Units (HP)	0.8		

NOTE

- (*) Follow the table 1 (see remarks) in order to optimise the indoor units balance.
- (**) When installing Indoor Units RCI-FSN3 or RCI-FSN3Ei, only 1 indoor unit combination is allowed.
- (***) When installing several Indoor Units and either RCI-FSN3 or RCI-FSN3Ei are present, the minimum allowed capacity for these series is 1.5 HP.

◆ **IVX Standard series**

		❄️🔥			
		Outdoor unit model			
		3 HP	4 HP	5 HP	6 HP
Maximum number of connected Indoor Units		2		4	
Connected capacity ratio of Indoor Unit % (number of connected Indoor Units)		90-110% (1 unit)		90-115% (≤ 2 units)	
		90-100% (2 units)		90-100% (3 or 4 units)	
Minimum capacity of Indoor Units (HP)		0.8			

		❄️🔥		
		Outdoor unit model		
		8 HP	10 HP	12 HP
Maximum number of connected Indoor Units		4		
Connected capacity ratio of Indoor Unit % (number of connected Indoor Units)		90-115%		
Minimum capacity of Indoor Units (HP)		1.8		

NOTE

Where the parameters of installation are close to their limit values (long Indoor-to-Indoor pipe distances, high outdoor-to-indoor height difference, long pipes in general, etc) it is recommended to follow the table 1 (see remarks) for best comfort.

◆ **Remarks**

1 Table 1

Indoor unit with the highest capacity (HP)	0.8	1.0	1.3	1.5	1.8	2.0	2.3	2.5	3.0	4.0	5.0	6.0	
Indoor Unit with the lowest capacity (HP)	0.8			1.0			1.3		1.5		1.8		2.0

2 In the systems where the model of all is 4-Way RCI-FSN3, the maximum capacity ratio of connected indoor units allowed is 100%, and the maximum number of connected indoor units are:

OU model	2 HP	2.5 HP	3 HP	4 HP	5 HP	6 HP	8 HP	10 HP	12 HP
OU Premium Series Max. number of IU	1		2		4		4		
OU Standard Series Max. number of IU	1		1		2		4		

- 3 When installing RCIM-2.0FSN2, RPF(I)-2.0FSN2E or RPF(I)-2.5FSN2E, 1 indoor unit combination with IVX Premium/Standard series not allowed.
- 4 In case of installation in cold territories (where Outdoor Temperature may fall below -10°C for Utopia IVX Premium and -5°C for Utopia IVX Standard) or in places where Heating load is large, install a number of units not bigger than suggested number of connected units, with a connected capacity ratio under 100%.
- 5 Please check the piping chapter for other restrictions and limitations to adequate the combinability and the number of indoor units installed.

◆ **Wide variety of standard command options**

The UTOPIA series has many standard commands. These options can be easily set by means of any of the wide variety of HITACHI remote controls, or through the PCBs of the indoor and outdoor units. In this way the UTOPIA series adapts to each installation.

2.3.3 Assisted air conditioning installation design by Hi-Tool kit selection software

The Hi-Tool Kit selection software is a tool for designing HVAC installations and automatically generating all necessary related information to complete the planned installation.

The necessary related information includes:

- Product selection table.
- Cooling and wiring diagram according to the installation design.
- Full list of necessary products to complete the installation.
- Installation start-up management.



2.4 Installation benefits

2.4.1 Easy and flexible electrical installation

◆ Adopting transmission system H-LINK II

The units interconnect via a bus called H-LINK II, consisting of 2 non-polarity cables and accepting lengths of up to 1,000 m. Accessories are available if required to increase this length to 5,000 m.

◆ Up to 160 indoor units connected to each circuit

Each H-LINK II bus can communicate up to 160 indoor units. Taking into account the absence of polarity and the length of line permitted, the flexibility of the interconnection between the machines is very high. This lets you, for example, connect the H-LINK II of a cooling system's indoor unit to the H-LINK II of another system's indoor unit.

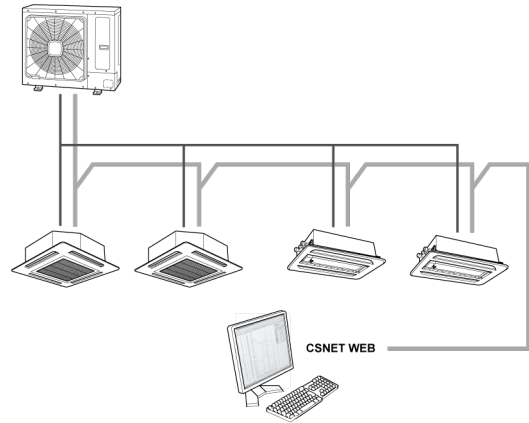

Specifications	
Transmission cable	2-wire
Polarity of transmission cable	Non-polar wire
Maximum refrigerant cycles	64 units per H-LINK II system
Maximum indoor units	160 units per H-LINK II system 64 units per refrigerant cycle.
Maximum number of equipment units	200
Maximum wiring length	Total 1,000 m (including CS-NET WEB)
Recommended cable	Shielded twisted pair cable or shielded pair cable, over 0.75 mm ² (equivalent to KPEV-S)
Voltage	DC 5 V

◆ No operating cable for the remote control (simultaneous operation setting)

In the case of multiple indoor unit systems, the indoor units with simultaneous operation setting can be controlled using a single remote control switch without having to join them with an operating cable for the remote control.

A. Operation wiring.

B. An operating cable is not required for using the remote control switch.

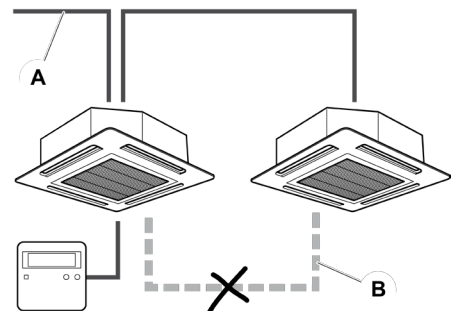

NOTE

- When using the H-LINK II system, DIP switches have to be adjusted. If the DIP switches are not set or they are set incorrectly, an alarm may occur due to transmission failure. Total wiring length for the remote control switch can be extended to up to 5,000 m. If total wiring length is less than 30 m, it is possible to use the normal wiring (0.3 mm²).

- *The H-LINK II system provides maximum flexibility for system design; installation is easy, and total costs are reduced. Furthermore, it can be controlled centrally by connecting CS-NET WEB to H-LINK II wiring.*
- *You can also control the installation by Internet via CS-NET WEB.*

2.4.2 Easy and flexible control connection (Central Station, BMS Interface, CS-NET WEB)

◆ **No polarity**

Thanks to the absence of polarity, any centralized control can be connected directly to the H-LINK II bus, which means that special lines are not needed.

◆ **Auto-Configuration**

Aside from the customized configuration, the control systems are also auto-configurable; for example, they have the capacity of interpreting the type of machine they are connected to, and detect the type of indoor unit or its HP.

2.5 Start-up benefits

2.5.1 Automatic start-up test

The installation is started up automatically, therefore considerably reducing the time required for the process.

There are the following types of start-up:

- Test run and identification of the units forming the system.
- Test run from the remote control.
- Test run from the outdoor unit.

◆ Test run and identification of the system units

The automatic test run can be activated through outdoor unit DIP switch or indoor unit remote control switch. The outdoor unit 7-segment display gives all the information needed to check the system is operating correctly.

The units forming part of the system are identified separately for the outdoor and indoor units:

- Outdoor units: Using the remote control, the series to which each of the operational outdoor unit belongs (for example, simple or multiple series) can be assigned.
- Indoor units: Using the rotary and DIP switch on each unit.

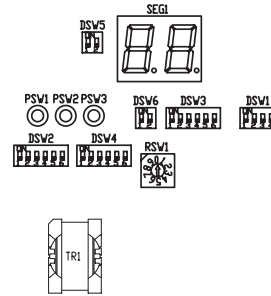

◆ Test run from the remote control

The remote control can run 3 operations.

- Auto-diagnostic: quick check of the operating conditions of the indoor units and the outdoor unit.
- Data memory query: if an abnormality occurs, the LCD remote control switch shows an alarm code and saves all the operation settings of the unit at the time the fault occurs, so that a quick diagnosis can be made of the installation.
- Optional function setting: the remote control switch allows cancellation of the 4-degree offset in the heating mode and an increase in the fan speed setting, among 29 possible options.



This way, multiple indoor units can be set at the same time. Also, the configuration can easily be changed, even after the installation has been completed.

◆ Test run from the outdoor unit

The outdoor unit PCB is equipped with a 7-segment display, which depending on the position of the PSWs shows the following parameters in sequence.

- Outdoor temperature.
- Discharge gas temperature.
- Evaporation temperature in heating mode.
- Condensing temperature.
- Discharge pressure.
- Compressor run time.

This allows quick and accurate diagnosis of the installation during normal operation or test run.

2.5.2 Service verification

◆ System operation control

The working order of the system is continuously monitored through the control system. All operating parameters that the system uses to manage the outdoor and indoor units are continuously supervised.

◆ **Assisted-management air conditioning system**

The air conditioning system can be managed conveniently using the assisted management software HITACHI Service Tools.

This software enables, for example, a laptop computer to be connected to the air conditioning system by means of an interface connected to the H-LINK II bus. Using different menus, the software allows you to manage all the systems connected effectively and obtain data to optimise system performance.



◆ **Compilation of operating data**

All the data obtained using HITACHI Service Tools is compiled in different formats and monitored in various ways. The user of the software can configure the data handling to monitor those parameters that are the most important in each installation.

The data reports allow you to verify the system operation continuously. Any deviation in the stipulated ranges of values are detected immediately.

2.6 Maintenance benefits

2.6.1 Minimum maintenance

The units have been designed in line with Hitachi's philosophy, guaranteeing great reliability and robustness and reducing maintenance to a minimum.

2.6.2 Easy accessibility

The system components are easily accessible. You can access all of the unit's components to perform any necessary operations through a simple cover. The entire system is designed for maintenance operations to be easy and simple.

2.6.3 Alarm codes

The alarms are grouped by elements within the system in order to facilitate maintenance work and optimize the fitter's job.



Availability of maintenance tools

All the functions of the Hitachi Service Tools for setup are applicable to unit maintenance, both preventive and corrective, so that any problem can be detected and solved immediately.

CSNET-WEB is also useful for maintenance tasks.

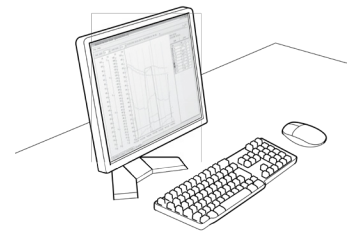

3 . General data

3

Contents

3. General data	31
3.1 General information.....	32
3.1.1 Combination with indoor units	32
3.1.2 Considerations	32
3.2 IVX Premium series.....	33
3.2.1 General specifications	33
3.2.2 Seasonal cooling/heating performance and EER/COP (2 - 4 HP)	37
3.2.3 EER/COP (5/6 HP).....	38
3.2.4 EER/COP (8-12 HP).....	38
3.3 IVX Standard series	39
3.3.1 General specifications	39
3.3.2 Seasonal cooling/heating performance and EER/COP (2 - 4 HP)	42
3.3.3 EER/COP (5/6 HP).....	42
3.3.4 EER/COP (8-12 HP).....	43
3.4 Component data	44
3.4.1 IVX Premium series.....	44
3.4.2 IVX Standard series	45
3.5 Electrical data.....	47
3.5.1 Considerations	47
3.5.2 IVX Premium series.....	47
3.5.3 IVX Standard series	47

3.1 General information

3.1.1 Combination with indoor units

All of the outdoor units described in this manual are combined with indoor units as indicated in the following table:

Outdoor units	Indoor units	Complementary system
IVX Premium / IVX Standard	RCI	KPI KPI Active DX-Interface
	RCIM	
	RCD	
	RPC	
	RPI	
	RPIM	
	RPK	
	RPF	
	RPFI	

3.1.2 Considerations

- 1 The nominal cooling and heating capacity is the combined capacity of the outdoor and indoor units system and is based on the EN14511, with the following operating conditions.

Operating conditions		Cooling	Heating
Indoor air inlet temperature	DB	32.0 °C	20.0 °C
	WB	19.0 °C	—
Outdoor air inlet temperature	DB	35.0 °C	7.0 °C
	WB	—	6.0 °C

DB: Dry Bulb; WB: Wet Bulb

Piping length: 7.5 meters; Piping lift: 0 meters

- 2 The tables show a 1 indoor unit system, 2 units system for 8, 10 and 4 units system for 12HP.
- 3 The SEER, SCOP, EER and COP are specified in the outdoor unit in combination with the referred indoor unit.
- 4 The sound pressure level were measured in an anechoic chamber, so reflected sound should be taken into consideration when installing the unit. Test were carried out under the following conditions.
 - Measurement point located: 1.5 m from floor level and 1 m from the unit front surface.
 - Units working with their nominal supply voltage.
- 5 Sound power levels were measured in a reverberant room, in accordance with the standard EN12102. Used environment conditions are the same that specified in EN14511 for performance test.
- 6 SEER and SCOP are according to EN 14825

3.2 IVX Premium series

3.2.1 General specifications

◆ 1~ 230V 50Hz

OUTDOOR UNITS		RAS-2HVNP	RAS-2.5HVNP	RAS-3HVNPE	RAS-4HVNPE
Power supply	-	1~ 230V 50Hz	1~ 230V 50Hz	1~ 230V 50Hz	1~ 230V 50Hz
Nominal cooling capacity (min-max)	kW	5.0 (2.2-5.6)	5.6 (2.2-6.3)	7.1 (3.2-8.0)	10.0 (4.5-11.2)
Nominal heating capacity (min-max)	kW	5.6 (2.2-7.1)	6.3 (2.2-8.0)	8.0 (3.5-10.6)	11.2 (5.0-14.0)
EER (*)		4.03	3.97	4.49	4.68
COP (*)		4.68	4.92	4.88	5.16
Minimum - Maximum indoor units connectable	-	1 - 2	1 - 2	1 - 3	1 - 5
Minimum - Maximum connected capacity	%	90% - 110%	90% - 110%	50% -120%	50% -120%
Noise level cooling (sound pressure) (night mode)	dB(A)	44 (42)	45 (43)	46 (42)	47 (43)
Noise level heating (sound pressure)	dB(A)	46	47	48	49
Noise level (sound power)	dB(A)	62	63	64	65
Air flow	m ³ /min	40.6	40.6	45	80
Dimensions (H x W x D)	mm	600 x 792 x 300	600 x 792 x 300	800 x 950 x 370	1380 x 950 x 370
Net weight	kg	41	41	66	103
Recommended circuit breaker	A	16	20	20	32
Starting current	A	Less than maximum current	Less than maximum current	Less than maximum current	Less than maximum current
Maximum current	A	12.0	14.0	19.0	28.0
Running current cooling	A	5.3	5.9	6.7	8.8
Running current heating	A	5.1	5.9	6.9	9.0
Power cable size (according to EN 60335-1)	quantity x mm ²	3 x 2.5	3 x 4.0	3 x 4.0	3 x 6.0
Transmitting cable size between indoor unit and outdoor unit	quantity x mm ²	2 x 0.75	2 x 0.75	2 x 0.75	2 x 0.75
Piping diameter (liquid / gas)	mm (inch)	Ø6.35 (1/4) / Ø12.7 (1/2)	Ø6.35 (1/4) / Ø12.7 (1/2)	Ø9.53 (3/8) / Ø15.88 (5/8)	Ø9.53 (3/8) / Ø15.88 (5/8)
Minimum piping length	m	5	5	5	5
Maximum piping length chargeless	m	30 (0 m for 2 indoor units system)	30 (0 m for 2 indoor units system)	30	30
Maximum piping length (additional refrigerant charge needed)	m (g/m)	50 (30)	50 (30 ⁽¹⁾)	50 (40)	75 (60)
Height difference (O.U. higher / O.U. lower)	m	30 / 20	30 / 20	30 / 20	30 / 20
Working range (cooling // heating)	°C	-5 / +46 (DB) // -20 / +15(WB)	-5 / +46 (DB) // -20 / +15(WB)	-5 / +46 (DB) // -20 / +15(WB)	-5 / +46 (DB) // -20 / +15(WB)
Refrigerant	-	R410A	R410A	R410A	R410A
Refrigerant charge before shipment	kg	1.6	1.6	2.3	4.1
Compressor type	-	Scroll DC Inverter driven	Scroll DC Inverter driven	Rotary DC Inverter driven	Scroll DC Inverter driven
Remote control model (Optional)		PC-ART / PC-ARF	PC-ART / PC-ARF	PC-ART / PC-ARF	PC-ART / PC-ARF

(*) COP and EER data are specified for RCI-FSN3 indoor units combination

(1) For 2 indoor units system the additional refrigerant charge needed is 24 g/m

3

OUTDOOR UNITS		RAS-5HVNP	RAS-6HVNP
Power supply	-	1~ 230V 50Hz	1~ 230V 50Hz
Nominal cooling capacity (min-max)	kW	12.5 (5.7-14.0)	14.0 (6.0-16.0)
Nominal heating capacity (min-max)	kW	14.0 (5.0-18.0)	16.0 (5.0-20.0)
EER (*)		3.81	3.41
COP (*)		4.55	4.23
Minimum - Maximum indoor units connectable	-	1 - 6	1 - 6
Minimum - Maximum connected capacity	%	50% -120%	50% -120%
Noise level cooling (sound pressure) (night mode)	dB(A)	48 (44)	48 (45)
Noise level heating (sound pressure)	dB(A)	50	50
Noise level (sound power)	dB(A)	66	67
Air flow	m ³ /min	90	100
Dimensions (H x W x D)	mm	1380 x 950 x 370	1380 x 950 x 370
Net weight	kg	103	103
Recommended circuit breaker	A	32	32
Starting current	A	Less than maximum current	Less than maximum current
Maximum current	A	28.0	28.0
Running current cooling	A	13.8	17.5
Running current heating	A	12.9	16.0
Power cable size (according to EN 60335-1)	quantity x mm ²	3 x 6.0	3 x 6.0
Transmitting cable size between indoor unit and outdoor unit	quantity x mm ²	2 x 0.75	2 x 0.75
Piping diameter (liquid / gas)	mm (inch)	Ø9.53 (3/8) / Ø15.88 (5/8)	Ø9.53 (3/8) / Ø15.88 (5/8)
Minimum piping length	m	5	5
Maximum piping length chargeless	m	30	30
Maximum piping length (additional refrigerant charge needed)	m (g/m)	75 (60)	75 (60)
Height difference (O.U. higher / O.U. lower)	m	30 / 20	30 / 20
Working range (cooling // heating)	°C	-5 / +46 (DB) // -20 / +15(WB)	-5 / +46 (DB) // -20 / +15(WB)
Refrigerant	-	R410A	R410A
Refrigerant charge before shipment	kg	4.2	4.2
Compressor type	-	Scroll DC Inverter driven	Scroll DC Inverter driven
Remote control model (Optional)		PC-ART / PC-ARF	PC-ART / PC-ARF

(*) COP and EER data are specified for RCI-FSN3 indoor units combination

◆ **3N~ 400V 50Hz**

OUTDOOR UNITS		RAS-4HNPE	RAS-5HNPE	RAS-6HNPE
Power supply	-	3N~ 400V 50Hz	3N~ 400V 50Hz	3N~ 400V 50Hz
Nominal cooling capacity (min-max)	kW	10.0 (4.5-11.2)	12.5 (5.7-14.0)	14.0 (6.0-16.0)
Nominal heating capacity (min-max)	kW	11.2 (5.0-14.0)	14.0 (5.0-18.0)	16.0 (5.0-20.0)
EER (*)		4.68	3.81	3.41
COP (*)		5.16	4.55	4.23
Minimum - Maximum indoor units connectable	-	1 - 5	1 - 6	1 - 6
Minimum - Maximum connected capacity	%	50% -120%	50% -120%	50% -120%
Noise level cooling (sound pressure) (night mode)	dB(A)	47 (43)	48 (44)	48 (45)
Noise level heating (sound pressure)	dB(A)	49	50	50
Noise level (sound power)	dB(A)	65	66	67
Air flow	m ³ /min	80	90	100
Dimensions (H x W x D)	mm	1380 x 950 x 370	1380 x 950 x 370	1380 x 950 x 370
Net weight	kg	103	103	103
Recommended circuit breaker	A	15	15	15
Starting current	A	Less than maximum current	Less than maximum current	Less than maximum current
Maximum current	A	11.5	11.5	13.5
Running current cooling	A	3.2	5.1	6.4
Running current heating	A	3.3	4.7	5.9
Power cable size (according to EN 60335-1)	quantity x mm ²	5 x 2.5	5 x 2.5	5 x 2.5
Transmitting cable size between indoor unit and outdoor unit	quantity x mm ²	2 x 0.75	2 x 0.75	2 x 0.75
Piping diameter (liquid / gas)	mm (inch)	Ø9.53 (3/8) / Ø15.88 (5/8)	Ø9.53 (3/8) / Ø15.88 (5/8)	Ø9.53 (3/8) / Ø15.88 (5/8)
Minimum piping length	m	5	5	5
Maximum piping length chargeless	m	30	30	30
Maximum piping length (additional refrigerant charge needed)	m (g/m)	75 (60)	75 (60)	75 (60)
Height difference (O.U. higher / O.U. lower)	m	30 / 20	30 / 20	30 / 20
Working range (cooling // heating)	°C	-5 / +46 (DB) // -20 / +15(WB)	-5 / +46 (DB) // -20 / +15(WB)	-5 / +46 (DB) // -20 / +15(WB)
Refrigerant	-	R410A	R410A	R410A
Refrigerant charge before shipment	kg	4.1	4.2	4.2
Compressor type	-	Scroll DC Inverter driven	Scroll DC Inverter driven	Scroll DC Inverter driven
Remote control model (Optional)		PC-ART / PC-ARF	PC-ART / PC-ARF	PC-ART / PC-ARF

(*) COP and EER data are specified for RCI-FSN3 indoor units combination

OUTDOOR UNITS		RAS-8HNPE	RAS-10HNPE	RAS-12HNPE
Power supply	-	3N~ 400V 50Hz	3N~ 400V 50Hz	3N~ 400V 50Hz
Nominal cooling capacity (min-max)	kW	20.0 (8.0-22.4)	25.0 (10.0-28.0)	30.0 (11.2-33.5)
Nominal heating capacity (min-max)	kW	22.4 (6.3-28.0)	28.0 (8.0-35.0)	33.5 (9.0-37.5)
EER (*)		3.56	3.07	2.65
COP (*)		4.21	3.84	3.64
Minimum - Maximum indoor units connectable	-	1 - 8	1 - 8	1 - 8
Minimum - Maximum connected capacity	%	50% -120%	50% -120%	50% -120%
Noise level cooling (sound pressure) (night mode)	dB(A)	57 (55)	58 (56)	59 (57)
Noise level heating (sound pressure)	dB(A)	59	60	61
Noise level (sound power)	dB(A)	76	76	77
Air flow (cooling / heating)	m ³ /min	127	134	163
Dimensions (H x W x D)	mm	1380 x 950 x 370	1380 x 950 x 370	1650 x 1100 x 390
Net weight	kg	136	138	168
Recommended circuit breaker	A	30	30	30
Starting current	A	Less than maximum current	Less than maximum current	Less than maximum current
Maximum current	A	24.0	24.0	24.3
Running current cooling	A	8.6	12.6	17.5
Running current heating	A	8.1	11.3	14.2
Power cable size (according to EN 60335-1)	quantity x mm ²	5 x 6.0	5 x 6.0	5 x 6.0
Transmitting cable size between indoor unit and outdoor unit	quantity x mm ²	2 x 0.75	2 x 0.75	2 x 0.75
Piping diameter (liquid / gas)	mm (inch)	Ø9.52 (3/8) / Ø25.4	Ø12.07 (1/2) / Ø25.4	Ø12.07 (1/2) / Ø25.4
Minimum piping length	m	5	5	5
Maximum piping length chargeless	m	30	30	30
Maximum piping length (additional refrigerant charge needed)	m (g/m)	100 (need to be calculate)	100 (need to be calculate)	100 (need to be calculate)
Height difference (O.U. higher / O.U. lower)	m	30 / 20	30 / 20	30 / 20
Working range (cooling // heating)	°C	-5 / +46 (DB) // -20 / +15(WB)	-5 / +46 (DB) // -20 / +15(WB)	-5 / +46 (DB) // -20 / +15(WB)
Refrigerant	-	R410A	R410A	R410A
Refrigerant charge before shipment	kg	5.7	6.2	6.7
Compressor type	-	Scroll DC Inverter driven	Scroll DC Inverter driven	Scroll DC Inverter driven
Remote control model (Optinal)		PC-ART / PC-ARF	PC-ART / PC-ARF	PC-ART / PC-ARF

3.2.2 Seasonal cooling/heating performance and EER/COP (2 - 4 HP)

System combination		Cooling				Heating			
Outdoor unit	Indoor unit	SEER	EER	Energy Class	P Design (35°C)	SCOP	COP	Energy Class	P Desing (-10°C)
		-	-	-	kW	-	-	-	kW
RAS-2HVNP	RCI-2.0FSN3	5.60	4.03	A+	5.0	4.66	4.68	A++	5.0
	RCI-2.0FSN3Ei	5.10	3.60	A	5.0	4.00	4.06	A+	5.0
	RCD-2.0FSN2	4.02	2.84	D	5.0	3.40	2.76	A	5.0
	RPC-2.0FSN2E	4.10	2.90	C	5.0	3.40	2.87	A	5.0
	RPI-2.0FSN4E	5.10	3.54	A	5.0	4.00	3.84	A+	5.0
	RPK-2.0FSN3M	4.82	2.92	B	5.0	4.00	3.21	A+	5.0
RAS-2.5HVNP	RCI-2.5FSN3	5.00	3.97	B	5.6	4.53	4.92	A+	5.2
	RCI-2.5FSN3Ei	4.92	3.46	B	5.6	4.35	4.00	A+	5.2
	RCD-2.5FSN2	4.16	3.03	C	5.6	4.00	3.29	A+	5.2
	RPC-2.5FSN2E	3.77	2.96	D	5.6	3.62	2.87	A	5.2
	RPI-2.5FSN4E	4.89	3.49	B	5.6	4.40	3.81	A+	5.2
	RPK-2.5FSN3M	4.61	2.97	B	5.6	4.13	3.16	A+	5.2
RAS-3HVNPE	RCI-3.0FSN3	6.15	4.49	A++	7.1	4.18	4.88	A+	6.4
	RCI-3.0FSN3Ei	5.60	3.97	A+	7.1	4.00	4.40	A+	6.0
	RCD-3.0FSN2	5.02	3.48	B	7.1	3.84	3.59	A	6.0
	RPC-3.0FSN2E	4.64	3.38	B	7.1	3.51	3.40	A	6.0
	RPI-3.0FSN4E	5.63	3.61	A+	7.1	4.03	3.95	A+	6.0
	RPK-3.0FSN3M	5.43	3.32	A	7.1	3.90	3.37	A	6.0
RAS-4HVNPE	RCI-4.0FSN3	6.82	4.68	A++	10.0	4.65	5.16	A++	11.5
	RCI-4.0FSN3Ei	6.27	4.02	A++	10.0	4.24	4.50	A+	11.5
	RCD-4.0FSN2	5.00	3.72	B	10.0	3.83	3.74	A	11.0
	RPC-4.0FSN2E	5.30	3.60	A	10.0	3.81	3.60	A	11.2
	RPI-4.0FSN4E	6.30	4.16	A++	10.0	4.40	4.23	A+	11.5
	RPK-4.0FSN3M	6.00	3.64	A+	10.0	3.81	3.44	A	9.0
RAS-4HNPE	RCI-4.0FSN3	6.65	4.68	A++	10.0	4.65	5.16	A++	11.5
	RCI-4.0FSN3Ei	6.13	4.02	A++	10.0	4.24	4.50	A+	11.5
	RCD-4.0FSN2	4.91	3.72	B	10.0	3.83	3.74	A	11.0
	RPC-4.0FSN2E	5.20	3.60	A	10.0	3.81	3.60	A	11.2
	RPI-4.0FSN4E	6.16	4.16	A++	10.0	4.40	4.23	A+	11.5
	RPK-4.0FSN3M	5.87	3.64	A+	10.0	3.81	3.44	A	9.0

3

3.2.3 EER/COP (5/6 HP)

System combination		Cooling		Heating	
Outdoor unit	Indoor unit	EER	Energy Class	COP	Energy Class
RAS-5HVNPE	RCI-5.0FSN3	3.81	A	4.55	A
	RCI-5.0FSN3Ei	3.47	A	3.90	A
	RCD-5.0FSN2	3.32	A	3.75	A
	RPC-5.0FSN2E	3.09	B	3.48	B
	RPI-5.0FSN4E	3.55	A	4.01	A
RAS-5HNPE	RCI-5.0FSN3	3.81	A	4.55	A
	RCI-5.0FSN3Ei	3.47	A	3.90	A
	RCD-5.0FSN2	3.32	A	3.75	A
	RPC-5.0FSN2E	3.09	B	3.48	B
	RPI-5.0FSN4E	3.55	A	4.01	A
RAS-6HVNPE	RCI-6.0FSN3	3.41	A	4.23	A
	RCI-6.0FSN3Ei	3.29	A	3.72	A
	RPC-6.0FSN2E	2.79	D	3.34	C
	RPI-6.0FSN4E	3.16	B	3.70	A
RAS-6HNPE	RCI-6.0FSN3	3.41	A	4.23	A
	RCI-6.0FSN3Ei	3.29	A	3.72	A
	RPC-6.0FSN2E	2.79	D	3.34	C
	RPI-6.0FSN4E	3.16	B	3.70	A

3.2.4 EER/COP (8-12 HP)

System combination		Cooling		Heating	
Outdoor unit	Indoor unit	EER	Energy Class	COP	Energy Class
RAS-8HNPE	2 x RCI-4.0FSN3	3.56	A	4.21	A
	RPI-8.0FSN3E	3.05	B	3.25	C
RAS-10HNPE	2 x RCI-5.0FSN3	3.07	B	3.84	A
	RPI-10.0FSN3E	2.93	C	3.22	C
RAS-12HNP	4 x RCI-3.0FSN3	2.65	D	3.64	A

3.3 IVX Standard series

3.3.1 General specifications

◆ 1~ 230V 50Hz

OUTDOOR UNITS		RAS-3HVNC	RAS-4HVNCE	RAS-5HVNCE	RAS-6HVNCE
Power supply	-	1~ 230V 50Hz	1~ 230V 50Hz	1~ 230V 50Hz	1~ 230V 50Hz
Nominal cooling capacity (min-max)	kW	7.1 (3.2-8.0)	10.0 (4.5-11.2)	12.5 (5.7-14.0)	14.0 (6.0-16.0)
Nominal heating capacity (min-max)	kW	8.0 (3.5-10.6)	11.2 (5.0-14.0)	14.0 (5.0-16.0)	16.0 (5.0-18.0)
EER (*)		3.14	3.80	3.16	2.77
COP (*)		4.00	4.29	3.88	3.59
Minimum - Maximum indoor units connectable	-	1 - 2	1 - 4	1 - 4	1 - 4
Minimum - Maximum connected capacity	%	90% - 110%	90% - 115%	90% - 115%	90% - 115%
Noise level cooling (sound pressure) (night mode)	dB(A)	48(46)	50(48)	52(50)	55(53)
Noise level heating (sound pressure)	dB(A)	50	52	54	57
Noise level (sound power)	dB(A)	66	70	71	72
Air flow	m ³ /min	44.7	62	68	80
Dimensions (H x W x D)	mm	600 x 792 x 300	800 x 950 x 370	800 x 950 x 370	800 x 950 x 370
Net weight	kg	44	67	79	79
Recommended circuit breaker	A	20	32	32	32
Starting current	A	Less than maximum current	Less than maximum current	Less than maximum current	Less than maximum current
Maximum current	A	16	28.0	28.0	28.0
Running current cooling	A	9.7	11.0	16.8	21.6
Running current heating	A	8.5	10.9	15.3	19.0
Power cable size (according to EN 60335-1)	quantity x mm ²	3 x 4.0	3 x 6.0	3 x 6.0	3 x 6.0
Transmitting cable size between indoor unit and outdoor unit	quantity x mm ²	2 x 0.75	2 x 0.75	2 x 0.75	2 x 0.75
Piping diameter (liquid / gas)	mm (inch)	Ø9.53 (3/8) / Ø15.88 (5/8)	Ø9.53 (3/8) / Ø15.88 (5/8)	Ø9.53 (3/8) / Ø15.88 (5/8)	Ø9.53 (3/8) / Ø15.88 (5/8)
Minimum piping length	m	5	5	5	5
Maximum piping length chargeless	m	20	30	30	30
Maximum piping length (additional refrigerant charge needed)	m (g/m)	50 (40)	70 (40)	75 (60)	75 (60)
Height difference (O.U. higher / O.U. lower)	m	30 / 20	30 / 20	30 / 20	30 / 20
Working range (cooling // heating)	°C	-5 / +46 (DB) // -20 / +15(WB)	-5 / +46 (DB) // -20 / +15(WB)	-5 / +46 (DB) // -20 / +15(WB)	-5 / +46 (DB) // -20 / +15(WB)
Refrigerant	-	R410A	R410A	R410A	R410A
Refrigerant charge before shipment	kg	1.9	2.9	2.9	2.9
Compressor type	-	Scroll DC Inverter driven	Rotary DC Inverter driven	Scroll DC Inverter driven	Scroll DC Inverter driven
Remote control model (Optional)		PC-ART / PC-ARF	PC-ART / PC-ARF	PC-ART / PC-ARF	PC-ART / PC-ARF

3

(*) COP and EER data are specified for RCI-FSN3 indoor units combination

◆ **3N~ 400V 50hz**

OUTDOOR UNITS		RAS-4HNCE	RAS-5HNCE	RAS-6HNCE
Power supply	-	3N~ 400V 50Hz	3N~ 400V 50Hz	3N~ 400V 50Hz
Nominal cooling capacity (min-max)	kW	10.0 (4.5-11.2)	12.5 (5.7-14.0)	14.0 (6.0-16.0)
Nominal heating capacity (min-max)	kW	11.2 (5.0-14.0)	14.0 (5.0-16.0)	16.0 (5.0-18.0)
EER (*)		3.80	3.16	2.77
COP (*)		4.29	3.88	3.59
Minimum - Maximum indoor units connectable	-	1 - 4	1 - 4	1 - 4
Minimum - Maximum connected capacity	%	90% - 115%	90% - 115%	90% - 115%
Noise level cooling (sound pressure) (night mode)	dB(A)	50(48)	52(50)	55(53)
Noise level heating (sound pressure)	dB(A)	52	54	57
Noise level (sound power)	dB(A)	70	71	72
Air flow (cooling / heating)	m ³ /min	62	68	80
Dimensions (H x W x D)	mm	800 x 950 x 370	800 x 950 x 370	800 x 950 x 370
Net weight	kg	67	79	79
Recommended circuit breaker	A	20	20	20
Starting current	A	Less than maximum current	Less than maximum current	Less than maximum current
Maximum current	A	15.0	15.0	15.0
Running current cooling	A	4.0	6.1	7.9
Running current heating	A	4.0	5.6	6.9
Power cable size (according to EN 60335-1)	quantity x mm ²	5 x 4.0	5 x 4.0	5 x 4.0
Transmitting cable size between indoor unit and outdoor unit	quantity x mm ²	2 x 0.75	2 x 0.75	2 x 0.75
Piping diameter (liquid / gas)	mm (inch)	Ø9.53 (3/8) / Ø15.88 (5/8)	Ø9.53 (3/8) / Ø15.88 (5/8)	Ø9.53 (3/8) / Ø15.88 (5/8)
Minimum piping length	m	5	5	5
Maximum piping length chargeless	m	30	30	30
Maximum piping length (additional refrigerant charge needed)	m (g/m)	70 (40)	75 (60)	75 (60)
Height difference (O.U. higher / O.U. lower)	m	30 / 20	30 / 20	30 / 20
Working range (cooling // heating)	°C	-5 / +46 (DB) // -20 / +15(WB)	-5 / +46 (DB) // -20 / +15(WB)	-5 / +46 (DB) // -20 / +15(WB)
Refrigerant	-	R410A	R410A	R410A
Refrigerant charge before shipment	kg	2.9	2.9	2.9
Compressor type	-	Rotary DC Inverter driven	Scroll DC Inverter driven	Scroll DC Inverter driven
Remote control model (Optional)		PC-ART / PC-ARF	PC-ART / PC-ARF	PC-ART / PC-ARF

(*) COP and EER data are specified for RCI-FSN3 indoor units combination

OUTDOOR UNITS		RAS-8HNCE	RAS-10HNCE	RAS-12HNC
Power supply	-	3N~ 400V 50Hz	3N~ 400V 50Hz	3N~ 400V 50Hz
Nominal cooling capacity (min-max)	kW	20.0 (8.0-22.4)	25.0 (10.0-28.0)	30.0 (11.2-33.5)
Nominal heating capacity (min-max)	kW	22.4 (6.3-28.0)	28.0 (8.0-35.0)	33.5 (9.0-37.5)
EER (*)		3.36	3.02	2.57
COP (*)		3.81	3.63	3.54
Minimum - Maximum indoor units connectable	-	1 - 4	1 - 4	1 - 4
Minimum - Maximum connected capacity	%	90% - 115%	90% - 115%	90% - 115%
Noise level cooling (sound pressure) (night mode)	dB(A)	57(55)	58(56)	59(56)
Noise level heating (sound pressure)	dB(A)	59	60	61
Noise level (sound power)	dB(A)	76	76	77
Air flow (cooling / heating)	m ³ /min	127	134	163
Dimensions (H x W x D)	mm	1380 x 950 x 370	1380 x 950 x 370	1650 x 1100 x 390
Net weight	kg	136	138	168
Recommended circuit breaker	A	30	30	30
Starting current	A	Less than maximum current	Less than maximum current	Less than maximum current
Maximum current	A	24.0	24.0	24.3
Running current cooling	A	9.1	12.9	18.1
Running current heating	A	9.0	12.0	14.6
Power cable size (according to EN 60335-1)	quantity x mm ²	5 x 6.0	5 x 6.0	5 x 6.0
Transmitting cable size between indoor unit and outdoor unit	quantity x mm ²	2 x 0.75	2 x 0.75	2 x 0.75
Piping diameter (liquid / gas)	mm (inch)	Ø9.52 (3/8) / Ø25.4	Ø12.07 (1/2) / Ø25.4	Ø12.07 (1/2) / Ø25.4
Minimum piping length	m	5	5	5
Maximum piping length chargeless	m	30	30	30
Maximum piping length (additional refrigerant charge needed)	m (g/m)	100 (need to be calculate)	100 (need to be calculate)	100 (need to be calculate)
Height difference (O.U. higher / O.U. lower)	m	30 / 20	30 / 20	30 / 20
Working range (cooling // heating)	°C	-5 / +46 (DB) // -20 / +15(WB)	-5 / +46 (DB) // -20 / +15(WB)	-5 / +46 (DB) // -20 / +15(WB)
Refrigerant	-	R410A	R410A	R410A
Refrigerant charge before shipment	kg	5.3	6.0	6.7
Compressor type	-	Scroll DC Inverter driven	Scroll DC Inverter driven	Scroll DC Inverter driven
Remote control model (Optional)		PC-ART / PC-ARF	PC-ART / PC-ARF	PC-ART / PC-ARF

3.3.2 Seasonal cooling/heating performance and EER/COP (2 - 4 HP)

System combination		Cooling				Heating			
Outdoor unit	Indoor unit	SEER	EER	Energy Class	P Design (35°C)	SCOP	COP	Energy Class	P Desing (-10°C)
		-	-	-	kW	-	-	-	kW
RAS-3HVNC	RCI-3.0FSN3	5.31	3.14	A	7.1	4.07	4.00	A+	5.6
	RCI-3.0FSN3Ei	4.87	3.01	B	7.1	3.95	3.83	A	5.6
	RCD-3.0FSN2	4.20	2.65	C	7.1	3.75	3.12	A	5.6
	RPC-3.0FSN2E	3.93	2.65	D	7.1	3.41	3.07	A	5.6
	RPI-3.0FSN4E	4.96	2.81	B	7.1	3.90	3.58	A	5.6
	RPK-3.0FSN3M	4.88	2.69	B	7.1	3.70	2.93	A	5.6
RAS-4HVNCE	RCI-4.0FSN3	5.16	3.80	A	10.0	3.92	4.29	A	8.0
	RCI-4.0FSN3Ei	4.88	3.30	B	10.0	3.83	3.88	A	8.0
	RCD-4.0FSN2	4.19	3.38	C	10.0	3.41	3.23	A	6.8
	RPC-4.0FSN2E	4.45	3.05	C	10.0	3.41	3.13	A	6.8
	RPI-4.0FSN4E	5.13	3.40	A	10.0	3.91	3.78	A	8.0
	RPK-4.0FSN3M	4.91	2.41	B	10.0	3.40	2.96	A	6.8
RAS-4HNCE	RCI-4.0FSN3	5.07	3.80	B	10.0	3.92	4.29	A	8.0
	RCI-4.0FSN3Ei	4.79	3.30	B	10.0	3.83	3.88	A	8.0
	RCD-4.0FSN2	4.13	3.38	C	10.0	3.41	3.23	A	6.8
	RPC-4.0FSN2E	4.38	3.05	C	10.0	3.41	3.13	A	6.8
	RPI-4.0FSN4E	5.03	3.40	B	10.0	3.91	3.78	A	8.0
	RPK-4.0FSN3M	4.83	2.41	B	10.0	3.40	2.96	A	6.8

3.3.3 EER/COP (5/6 HP)

System combination		Cooling		Heating	
Outdoor unit	Indoor unit	EER	Energy Class	COP	Energy Class
RAS-5HVNCE	RCI-5.0FSN3	3.16	B	3.88	A
	RCI-5.0FSN3Ei	3.09	B	3.72	A
	RCD-5.0FSN2	2.90	C	3.54	B
	RPC-5.0FSN2E	2.80	D	3.09	D
	RPI-5.0FSN4E	3.09	B	3.60	B
RAS-5HNCE	RCI-5.0FSN3	3.16	B	3.88	A
	RCI-5.0FSN3Ei	3.09	B	3.72	A
	RCD-5.0FSN2	2.90	C	3.54	B
	RPC-5.0FSN2E	2.80	D	3.09	D
	RPI-5.0FSN4E	3.09	B	3.60	B
RAS-6HVNCE	RCI-6.0FSN3	2.77	D	3.59	B
	RCI-6.0FSN3Ei	2.61	D	3.41	B
	RPC-6.0FSN2E	2.55	E	3.07	D
	RPI-6.0FSN4E	2.70	D	3.45	B
RAS-6HNCE	RCI-6.0FSN3	2.77	D	3.59	B
	RCI-6.0FSN3Ei	2.61	D	3.41	B
	RPC-6.0FSN2E	2.55	E	3.07	D
	RPI-6.0FSN4E	2.70	D	3.45	B

3.3.4 EER/COP (8-12 HP)

System combination		Cooling		Heating	
Outdoor unit	Indoor unit	EER	Energy Class	COP	Energy Class
RAS-8HNCE	2 x RCI-4.0FSN3	3.36	A	3.81	A
	RPI-8.0FSN3E	2.84	C	3.07	D
RAS-10HNCE	2 x RCI-5.0FSN3	3.02	B	3.63	A
	RPI-10.0FSN3E	2.73	D	3.04	D
RAS-12HNC	4 x RCI-3.0FSN3	2.57	E	3.54	B

3

3.4 Component data

3.4.1 IVX Premium series

◆ RAS-(2-3)HVNP(E)

MODEL		RAS-2HVNP	RAS-2.5HVNP	RAS-3HVNP(E)
Heat exchanger	Type		Multi-pass cross-finned tube	
	Pipe material		Copper	
	Outer diameter	mm	8	7
	Rows		2	2
	No. of tubes in the Heat exchanger		44	76
	Fin material		Aluminium	
	Fin pitch		1.45	1.4
	Maximum operating pressure	MPa	4.15	
	Total front area	m ²	0.47	34.9
	No. of Heat exchanger per unit		1	
Fan	Fan type		Direct drive propeller fan	
	Fans per unit		1	
	Outer diameter	mm	449	544
	Revolutions	rpm	770	465
	Nominal air flow	m ³ /min	41	45
Motor	Shell		Drip-proof type enclosure	
	Starting		Direct current control	
	Power	W	40	100
	Quantity		1	1
	Insulation class		E	E
Compressor		EU1114D9	EU140XA2	2YC45KXD

◆ RAS-S(4-6)HVNP(E)

MODEL		RAS-4H(V)NPE	RAS-5H(V)NPE	RAS-6H(V)NPE	
Heat exchanger	Type		Multi-pass Cross finned tube		
	Pipe material		Copper		
	Outer diameter	mm	7		
	Rows		2		
	No. of tubes in the Heat exchanger		132		
	Fin material		Aluminium		
	Fin pitch		1.4		
	Maximum operating pressure	MPa	4.15		
	Total front area	m ²	1.35		
	No. of Heat exchanger per unit		1		
Fan	Fan type		Direct drive propeller fan		
	Fans per unit		2		
	Outer diameter	mm	544		
	Revolutions	rpm	459/376	516/422	573/469
	Nominal air flow	m ³ /min	80	90	100
Motor	Shell		Drip-proof type enclosure		
	Starting		Direct current control		
	Power	W	100 + 100		
	Quantity		2		
	Insulation class		E		
Compressor		E402HHD-36A2 (1~) / E402HHD-36D2 (3N~)			

◆ **RAS-(8-12)HNP(E)**

MODEL		RAS-8HNPE	RAS-10HNPE	RAS-12HNP	
Heat exchanger	Type	Multi-pass cross-finned tube			
	Pipe material	Copper			
	Outer diameter	mm	7		
	Rows		3	2	
	No. of tubes in the Heat exchanger		198	160	
	Fin material	Aluminium			
	Fin pitch		1.4		
	Maximum Heat exchanger pressure	MPa	4.15		
	Total front area	m ²	1.35	1.86	
No. of evaporators per unit		1			
Fan	Fan type	Direct drive propeller fan			
	Fans per unit	2			
	Outer diameter	mm	544		
	Revolutions	rpm	586/717	644/787	630/880
	Nominal air flow	m ³ /min	127	134	163
Motor	Shell	Drip-proof type enclosure			
	Starting	Direct current control			
	Power	W	100 + 100		
	Quantity		2		
	Insulation class		E		
Compressor		DA50PHD-D1SE2	DA65PHD-D1SE2		

3.4.2 IVX Standard series

◆ **RAS-(3-6)HVNC(E)**

MODEL		RAS-3HVNC	RAS-4H(V)NCE	RAS-5H(V)NCE	RAS-6H(V)NCE	
Heat exchanger	Type	Multi-pass cross-finned tube				
	Pipe material	Copper				
	Outer diameter	mm	8	7		
	Rows		2	2	2	
	No. of tubes in the Heat exchanger		44	132		
	Fin material	Aluminium				
	Fin pitch		1.45	1.4		
	Maximum operating pressure	MPa	4.15			
	Total front area	m ²	0.47	0.77		
No. of Heat exchanger per unit		1				
Fan	Fan type	Direct drive propeller fan				
	Fans per unit		1	1		
	Outer diameter	mm	449	544		
	Revolutions	rpm	850	690	700	750
	Nominal air flow	m ³ /min	45	68	68	74
Motor	Shell	Drip-proof type enclosure				
	Starting	Direct current control				
	Power	W	40	190		
	Quantity		1	1		
	Insulation class		E	E		
Compressor		EU180XA1	2YC63FXD (1~) / 2YC63RXD (3N~)	E401HHD-36A2 (1~) / E401HHD-36D2 (3N~)		

◆ **RAS-(8-12)HNC(E)**

MODEL		RAS-8HNCE	RAS-10HNCE	RAS-12HNC	
Heat exchanger	Type	Multi-pass cross-finned tube			
	Pipe material	Copper			
	Outer diameter	mm	7		
	Rows		3	2	
	No. of tubes in the Heat exchanger		198	160	
	Fin material	Aluminium			
	Fin pitch	1.4			
	Maximum operating pressure	MPa	4.15		
	Total front area	m ²	1.35	1.86	
No. of Heat exchanger per unit		1			
Fan	Fan type	Direct drive propeller fan			
	Fans per unit	2			
	Outer diameter	mm	544		
	Revolutions	rpm	586/717	640/787	630/880
	Nominal air flow	m ³ /min	127	134	163
Motor	Shell	Drip-proof type enclosure			
	Starting	Direct current control			
	Power	W	100 + 100		
	Quantity	2			
	Insulation class	E			
Compressor		DA50PHD-D1SE2	DA65PHD-D1SE2		

3.5 Electrical data

3.5.1 Considerations

Keywords:

- U: Power supply.
- PH: Phase.
- f: Frequency.
- STC: Starting current: Less than maximum current.
- IPT: Total input power.
- RNC: Running current.
- MC: Maximum current.
- CB: Circuit breaker (A)
- ELB: Earth leakage breaker (N°. of poles/A/mA)



NOTE

- Specifications in these tables are subject to change without notice in order that HITACHI may bring the latest innovations to their customers.
- Cooling conditions: Indoor air inlet: 20 °C DB; Outdoor air inlet: 7/6 °C (DB/WB).
- Heating conditions: Indoor air inlet: 27/19 °C (DB/WB); Outdoor air inlet: 35 °C DB.

3.5.2 IVX Premium series

Outdoor unit	Main unit power			Applicable voltage		Compressor and fan motor						CB (A)	ELB		
	U (V)	PH	f (Hz)	U max (V)	U min (V)	STC (A)	Cooling		Heating		Max. IPT (kW)			MC (A)	
							IPT (kW)	RNC (A)	IPT (kW)	RNC (A)					
RAS-2HVNP	230	1	50	253	207	-	1.20	5.3	1.16	5.1	2.73	12.0	16	2/40/30	
RAS-2.5HVNP							1.34	5.9	1.35	5.9	3.19	14.0			20
RAS-3HVNP							1.52	6.7	1.58	6.9	4.33	19.0			20
RAS-4HVNP							2.01	8.8	2.04	9.0	6.38	28.0			32
RAS-5HVNP							3.15	13.8	2.95	12.9	6.38	28.0			32
RAS-6HVNP							3.98	17.5	3.65	16.0	6.38	28.0			32
RAS-4HNPE	400	3	50	440	360	-	2.01	3.2	2.04	3.3	7.17	11.5	15	4/40/30	
RAS-5HNPE							3.15	5.1	2.95	4.7	7.17	11.5			15
RAS-6HNPE							3.98	6.4	3.65	5.9	8.42	13.5			15
RAS-8HNPE							5.36	8.6	5.06	8.1	15.0	24.0			30
RAS-10HNPE							7.88	12.6	7.03	11.3	15.0	24.0			30
RAS-12HNP							11.05	17.5	8.96	14.2	15.3	24.3			30

3.5.3 IVX Standard series

Outdoor unit	Main unit power			Applicable voltage		Compressor and fan motor						CB (A)	ELB		
	U (V)	PH	f (Hz)	U max (V)	U min (V)	STC (A)	Cooling		Heating		Max. IPT (kW)			MC (A)	
							IPT (kW)	RNC (A)	IPT (kW)	RNC (A)					
RAS-3HVNC	230	1	50	253	207	-	2.20	9.7	1.94	8.5	3.64	16.0	20	2/40/30	
RAS-4HVNCE							2.50	11.0	2.48	10.9	6.38	28.0			32
RAS-5HVNCE							3.83	16.8	3.48	15.3	6.38	28.0			32
RAS-6HVNCE							4.92	21.6	4.33	19.0	6.38	28.0			32
RAS-4HNCE	400	3	50	440	360	-	2.50	4.0	2.48	4.0	9.35	15.0	20	4/40/30	
RAS-5HNCE							3.83	6.1	3.48	5.6	9.35	15.0			20
RAS-6HNCE							4.92	7.9	4.33	6.9	9.35	15.0			20
RAS-8HNCE							5.69	9.1	5.62	9.0	15.0	24.0			30
RAS-10HNCE							8.02	12.9	7.45	12.0	15.0	24.0			30
RAS-12HNCE							11.42	18.1	9.21	14.6	15.3	24.3			30

4 . Capacities and selection data

Contents

4. Capacities and selection data.....	49
4.1 Combinability range	50
4.2 System selection procedure	51
4.2.1 Selection procedure (step 1)	51
4.2.2 Selection procedure (step 2)	53
4.3 Maximum cooling capacity curve	54
4.3.1 IVX Premium series.....	54
4.3.2 IVX Standard series	58
4.4 Maximum heating capacity curve	62
4.4.1 IVX Premium series.....	62
4.4.2 IVX Standard series	66
4.5 Correction curve factor	70
4.5.1 Cooling	70
4.5.2 Heating	70
4.6 Piping length correction factor.....	71
4.6.1 IVX Premium series.....	71
4.6.2 IVX Standard series	74
4.7 Correction factor / ratio.....	76
4.7.1 Defrost Operation correction factor	76
4.7.2 Correction ratio due to humidity (CR).....	76

4.1 Combinability range

◆ IVX Premium series

Range of operation capacity control from 50% up to 120% (from 90 up to 110% for 2 and 2.5HP outdoor units).

Outdoor unit	Minimum combination capacity (HP)	Maximum combination capacity (HP)	Maximum Combination quantity	Minimum indoor unit capacity (HP)
RAS-2HVNP	1.8	2.2	2	0.8 (*)
RAS-2.5HVNP	2.25	2.75	2	0.8 (**)
RAS-3HVNP	1.5	3.6	3	0.8
RAS-4H(V)NPE	2.0	4.8	5	0.8
RAS-5H(V)NPE	2.5	6.0	6	0.8
RAS-6H(V)NPE	3.0	7.2	6	0.8
RAS-8HNPE	4.0	9.6	8	0.8
RAS-10HNPE	5.0	12.0	8	0.8
RAS-12HNP	6.0	14.4	8	0.8

◆ IVX Standard series

Range of operation capacity control from 90% up to 115% (from 90 up to 110% for 3HP outdoor unit).

Outdoor unit	Minimum combination capacity (HP)	Maximum combination capacity (HP)	Maximum Combination quantity	Minimum indoor unit capacity (HP)
RAS-3HVNC	2.7	3.5	3	0.8
RAS-4H(V)NCE	3.6	4.6	4	0.8
RAS-5H(V)NCE	4.5	5.8	4	0.8
RAS-6H(V)NCE	5.4	6.9	4	0.8
RAS-8HNCE	7.2	9.2	4	1.8
RAS-10HNCE	9.0	11.5	4	1.8
RAS-12HNC	10.8	13.8	4	1.8



NOTE

- (*) When installing Indoor Units RCI-FSN3 or RCI-FSN3Ei, only single combination is allowed.
- (**) When installing several Indoor Units and either RCI-FSN3 or RCI-FSN3Ei are present, the minimum allowed capacity for these series is 1.5 HP.



REMARKS

- 1 When installing RCIM-2.0FSN2, RPF(I)-2.0FSN2E or RPF(I)-2.5FSN2E, single combination with IVX Premium/Standard series not allowed.
- 2 In case of installation in cold territories (where Outdoor Temperature may fall below -10°C for Utopia IVX Premium and -5°C for Utopia IVX Standard) or in places where Heating load is large, install a number of units not bigger than suggested number of connected units, with a connected capacity ratio under 100%.
- 3 Please check the piping chapter for other restrictions and limitations to adequate the combinability and the number of indoor units installed.
- 4 See "Piping work and refrigerant charge" for detailed information and additional remarks about combinability.

4.2 System selection procedure

This combinability allows the outdoor unit to be smaller capacity when compared with other air conditioning systems, in case of the total combination horsepower, but considering that maximum load demands can not be simultaneous.

A: morning peak heat load in the eastern area.

B: evening peak heat load in the western area.

C: maximum simultaneous load for the entire building.

D: eastern area load.

E: total load.

F: western area load.

G: load.

H: time.

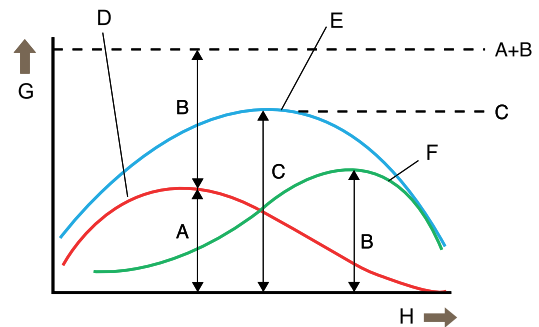

The diagram shows a typical building with a morning peak heat load on the east zone equivalent to a 3 HP unit. In the afternoon a peak occurs on the west zone equivalent to a 3.5 HP unit.

Therefore, a conventional system would require total installed plant of 3 HP + 3.5 HP = 6.5 HP (next capacity available is 8 HP). The maximum simultaneous load on the whole building occurs at noon and is equivalent to a 6 HP capacity. A RAS-6H(V)NPE unit can be selected, and this capacity can be directed either to the east or west zone as dictated by the systems controls. Then the IVX Premium series 6 HP outdoor unit can be selected, against the 8 HP required in a typical system (25% reduction).

The following figure shows the capacity curve depending on the combined indoor units.

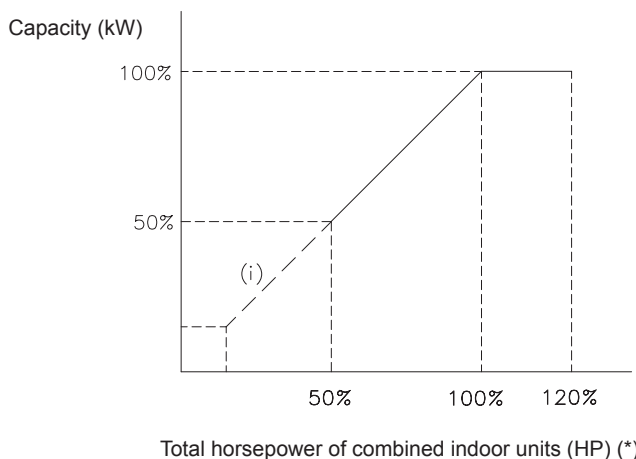

i NOTE

(*) This range can be different depending the outdoor and indoor unit model.

(i) Capacity when some indoor units are off

4.2.1 Selection procedure (step 1)

Considering the layout of the building, the possible position of the indoor units and the air flow distribution, select the unit features that provide the greatest efficiency and comfort. Decide a position for the outdoor unit that facilitates service and maintenance tasks.

1 Determine the total load required for each room.

2 Select, per each room, the appropriate Indoor Unit according to the required load and the installation characteristics.

In some, situations, it should be useful to adjust the capacity of the indoor units in order to adapt the unit to the actual installation requirements. This function is performed by dip switch setting and it's possible in some HP indoor unit models.

In case of an installation with ducts (outdoor unit with RPI indoor unit) the fan performance for duct calculations should be considered. The RPI units are designed with different static pressure ranges in order to fulfil all installation necessities.

3 Pre-select the outdoor units that covers the installation's cooling load requirements.

If the required loads will not be simultaneous (for example: the maximum required loads of room 1 (east zone) occurs at

the morning and the maximum required loads of room 2 (west zone) occurs at the afternoon.), select the outdoor unit that cover the maximum simultaneous load on the installation and check that the total combination horsepower must not be higher than the limits, using the following:

$$\text{Total combination horsepower} = (\text{Total indoor unit horsepower} / \text{Outdoor unit horsepower}) \times 100$$

4 Calculation of f_{LC} (Cooling piping length correction factor)

The length of the refrigerant piping used and the height difference between the outdoor unit and the indoor units directly affect the performance of the unit. This concept is quantified in the piping length correction factor.

To determine this value it is necessary refer to the piping length correction factor tables that are based on the equivalent piping length in meter and height between outdoor and indoor units. For the equivalent one-way piping length between indoor unit and outdoor unit (m) consider the following:

One 90° elbow is 0.5 m.

One 180° bend is 1.5 m.

One Multi-kit is 0.5 m.

5 Cooling capacity correction (Q_c) due to the piping length

The actual cooling capacity of the pre-selected unit must be calculated applying the necessary correction factors:

$$Q_c = Q_{MC} \times f_{LC}$$

Q_c : Actual cooling capacity of the outdoor unit (kW).

Q_{MC} : Maximum cooling capacity of the outdoor unit (kW).

f_{LC} : Cooling piping length correction factor.

6 Cooling capacity correction of the outdoor unit (Q_{AC}) depending of the humidity of the indoor unit

The correction ratio due to humidity is the coefficient that corrects the sensible heat capacity of a unit according to the relative humidity of the air entering the indoor unit. The greater the relative humidity the lower will be the sensible heat capacity and vice versa.

The following formula is used to apply an adjustment to the cooling capacity showed in the tables due to the difference between the real indoor air inlet dry bulb temperature vs the one used for calculate the nominal cooling capacity data.

$$Q_{AC} = Q_c + (CR \times (DB_R - DB))$$

Q_{AC} : Actual cooling capacity of the outdoor unit (kW) (at given real % humidity)

Q_c : Corrected cooling capacity of the outdoor unit by piping length (kW) (at given 50 % humidity)

CR: Correction ratio due to humidity.

DB_R : Real Dry Bulb evaporator temperature (°C).

DB: Dry Bulb evaporator temperature (°C) for each wet bulb temperature from the curves (HR = 50 %).

7 Actual indoor units capacity

Once it is known the actual outdoor units cooling capacity, it must be calculated the actual cooling capacity of each indoor unit, according to the following formula:

$$Q_{CI} = Q_{AC} \times (Q_{NCl} / Q_{NCC})$$

Q_{CI} : Actual cooling capacity of the indoor unit (kW).

Q_{AC} : Actual cooling capacity of the outdoor unit (kW).

Q_{NCl} : Nominal cooling capacity of the indoor unit (kW).

Q_{NCC} : Nominal cooling capacity of the combination (kW).

8 Sensible heat capacity (SHC)

Once the calculation of the indoor units cooling capacity has been completed, the sensible heat capacity can be calculated using the following formula:

$$SHC = Q_{CI} \times SHF$$

SHC: Sensible heat capacity (kW).

Q_{CI} : Actual cooling capacity of the indoor unit (kW).

SHF: Sensible heat factor.

9 Checks

Check that the total capacity and sensible heat capacity (SHC) are greater than the estimated cooling load by the different rooms to be conditioned. Therefore, it can be said that the selected outdoor unit meets the minimum cooling requirements set for the system.

$$\begin{array}{lcl}
 \text{Corrected total cooling capacity (kW)}_{\text{TOTAL}} & \geq & \text{Estimated total cooling load (kW)}_{\text{TOTAL}} \\
 \text{Corrected sensible heat capacity (kW)}_{\text{TOTAL}} & \geq & \text{Estimated sensible heat capacity (kW)}_{\text{TOTAL}} \\
 \text{Corrected total cooling capacity (kW)}_{\text{ROOMn}} & \geq & \text{Estimated total cooling load (kW)}_{\text{ROOMn}} \\
 \text{Corrected sensible heat capacity (kW)}_{\text{ROOMn}} & \geq & \text{Estimated sensible heat capacity (kW)}_{\text{ROOMn}}
 \end{array}$$

4.2.2 Selection procedure (step 2)

1 Calculate the heating requirements for each room

See if the pre-selected indoor units and outdoor units have the necessary nominal heating capacity for each room.

2 Heating capacity correction (Q_H)

The actual heating capacity of the pre-selected outdoor unit (in cooling mode (step 1)) must be calculated applying the necessary correction factors:

$$Q_H = Q_{MH} \times f_{LH} \times f_D$$

- Q_H : Actual heating capacity of the outdoor unit (kW)
- Q_{MH} : Maximum heating capacity of the outdoor unit (kW)
- f_{LH} : Heating piping length correction factor
- f_D : Defrost correction factor

Calculation of f_{LH}

Referring to the diagrams for "Piping length correction factor"

Calculation of f_D

In situations where the ambient temperature is lower than 7 °C DB, frost may build up on the heat exchanger. In this case, the heating capacity for the unit may be reduced because of the time spent by the unit in removing the frost up.

The defrost correction factor takes this time into account to apply the heating capacity correction.

3 Heating capacity of each indoor unit (Q_{HI})

Once the real heating capacity of the outdoor unit has been determined, its heating capacity in combination with the indoor units, can be calculated.

$$Q_{HI} = Q_H \times (Q_{NHI} / Q_{NHC})$$

- Q_{HI} : Actual heating capacity of the indoor unit (kW)
- Q_H : Actual heating capacity of the outdoor unit (kW)
- Q_{NHI} : Nominal heating capacity of the indoor unit (kW)
- Q_{NHC} : Nominal heating capacity of the combination (kW)

If the corrected heating capacity is greater than the estimated heating load by the different rooms to be conditioned, it can be said that the selection is valid for both cooling and heating.

$$\begin{array}{lcl}
 \text{Actual heating capacity (kW)}_{\text{TOTAL}} & \geq & \text{Estimated heating capacity (kW)}_{\text{TOTAL}} \\
 \text{Actual heating capacity (kW)}_{\text{ROOMn}} & \geq & \text{Estimated heating capacity (kW)}_{\text{ROOMn}}
 \end{array}$$

4.3 Maximum cooling capacity curve

Curves are based on the following conditions:

Piping Length/Height difference: 7.5 m / 0 m

The point "o" on the curves is based on the following conditions:

Indoor air inlet temperature: 27°C (DB) / 19 °C (WB)

Outdoor air inlet temperature: 35°C (DB)

The curves are based on High speed of indoor fan. To calculate the cooling capacity of medium or low speed of indoor fan, multiply cooling capacity of high speed by Correction Curve Factor (Chapter 4.5).

All temperatures in °C.

4.3.1 IVX Premium series

◆ RAS-2HVNP

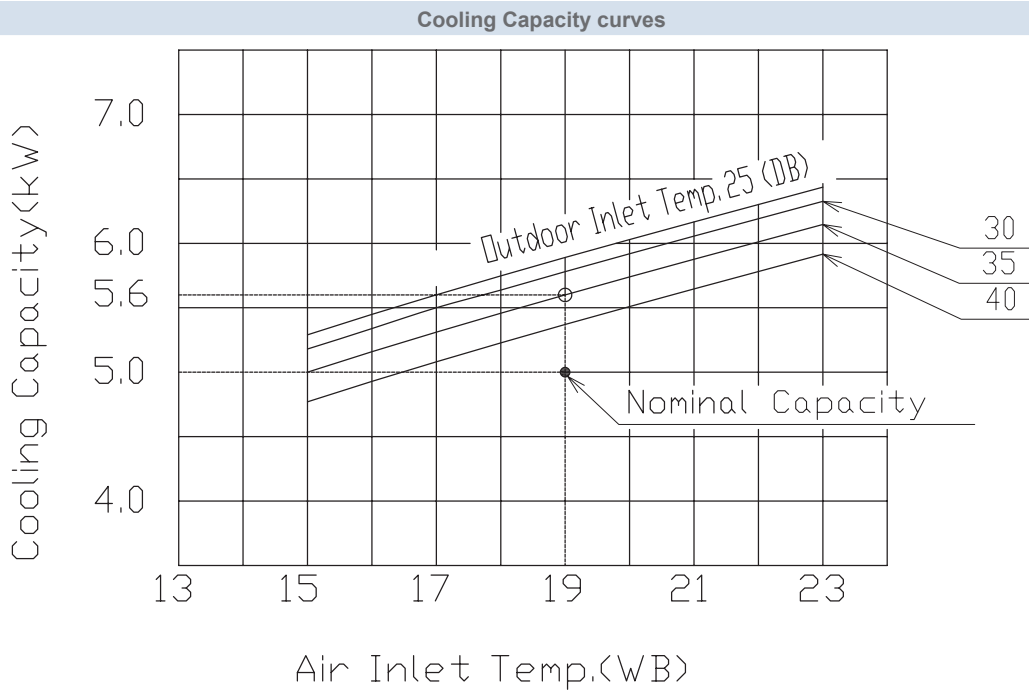

7S139298

◆ RAS-2.5HVNP

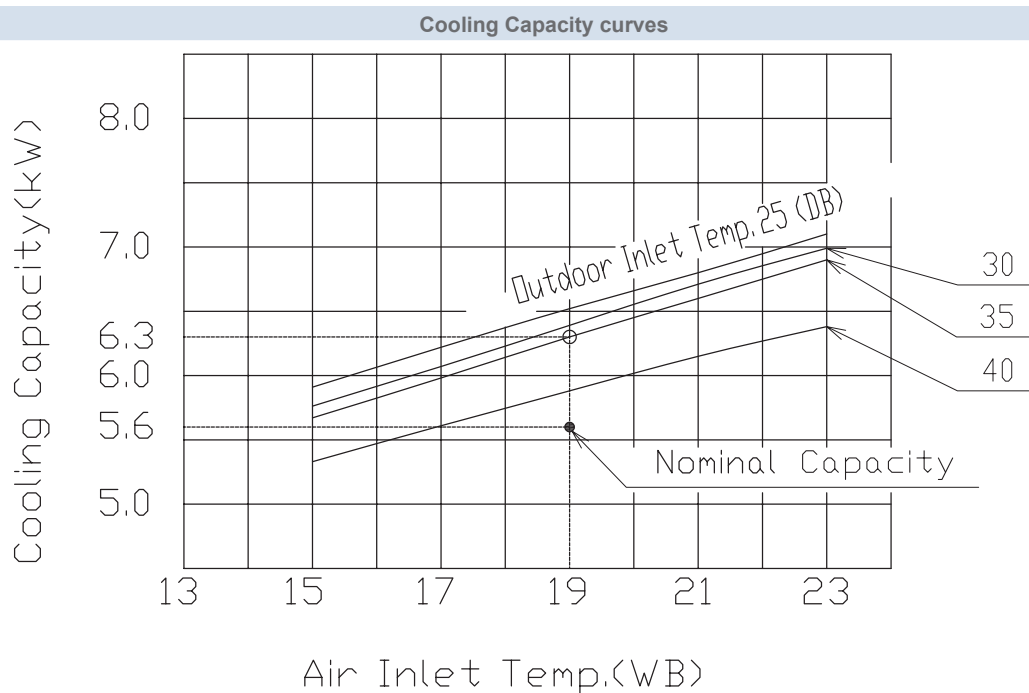

7S139299

◆ **RAS-3HVNPE**

Cooling Capacity curves

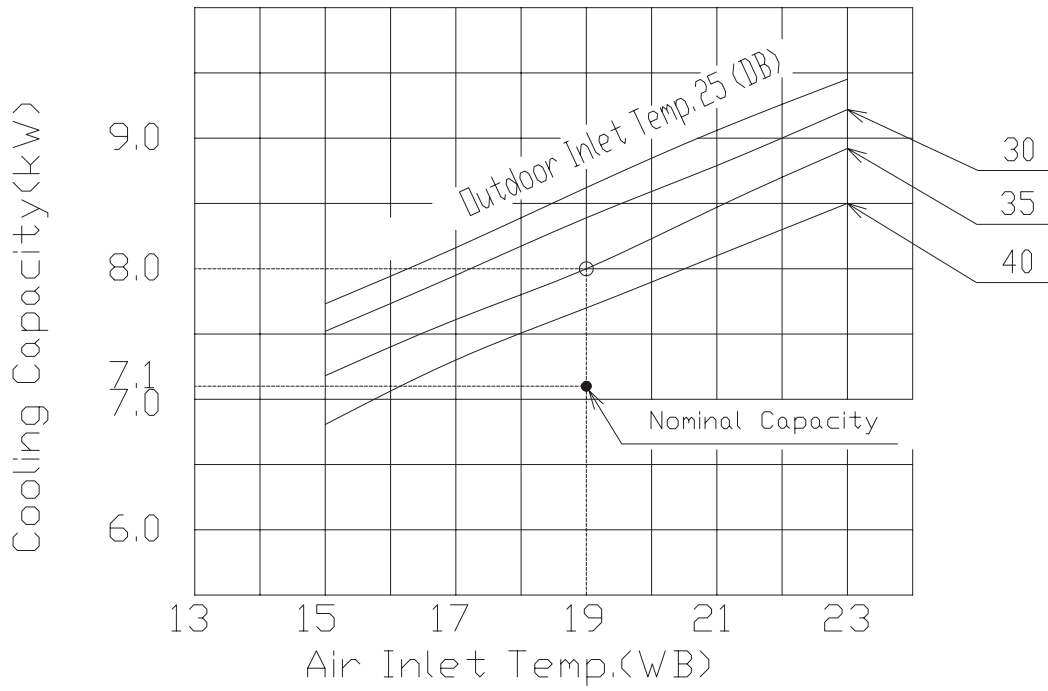

7S138312

◆ **RAS-4H(V)NPE**

Cooling Capacity curves

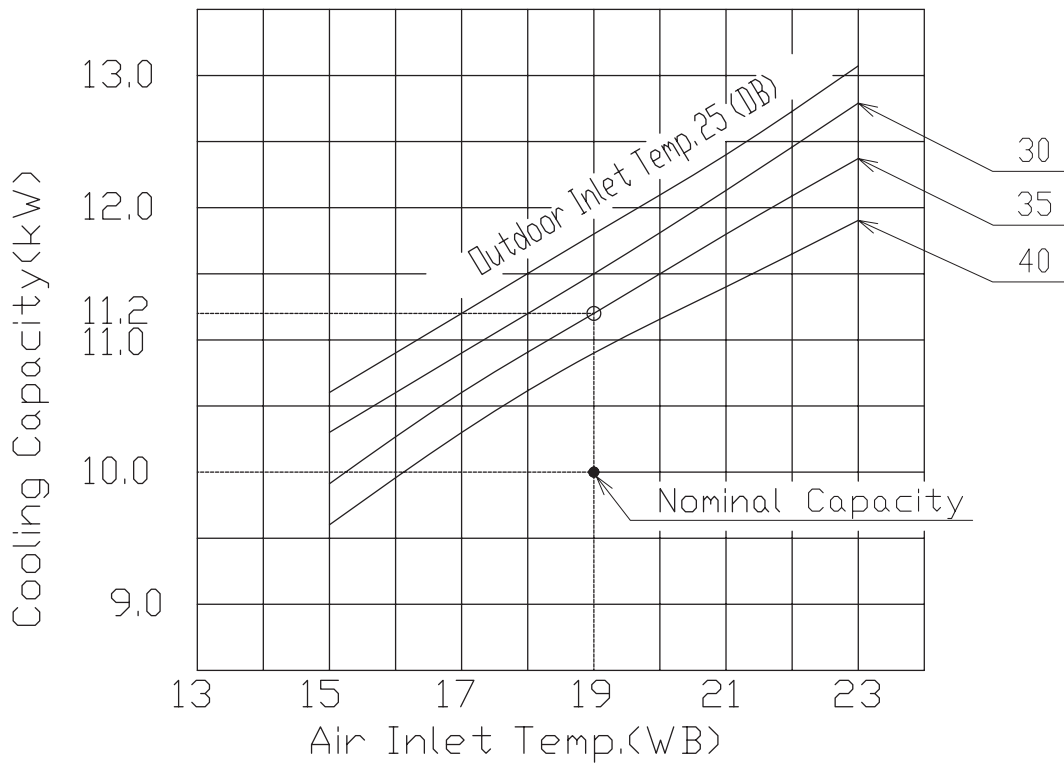

7S139313

◆ **RAS-5H(V)NPE**

Cooling Capacity curves

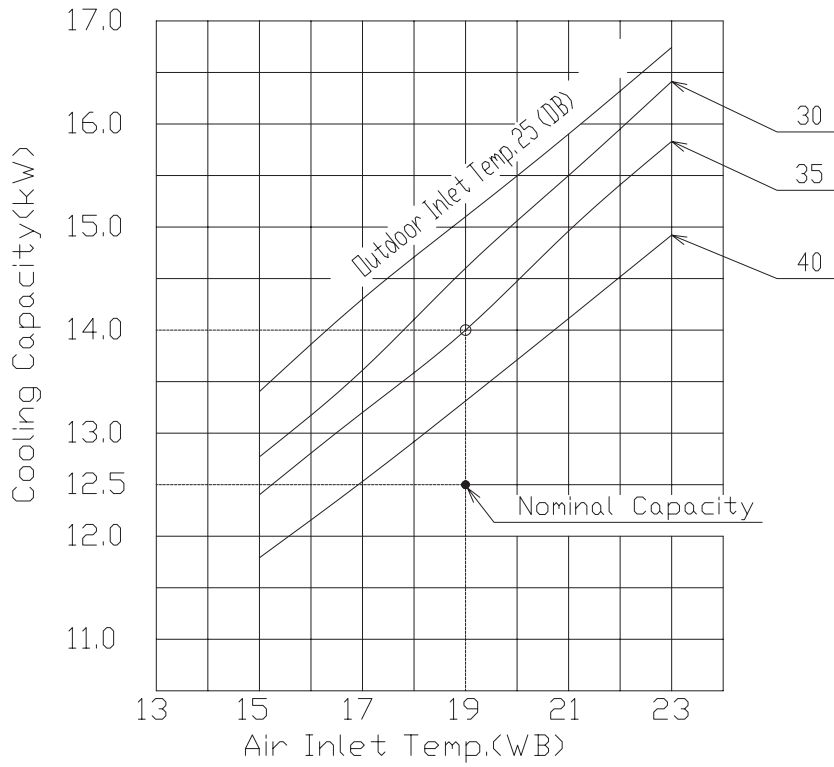

7S138314

◆ **RAS-6H(V)NPE**

Cooling Capacity curves

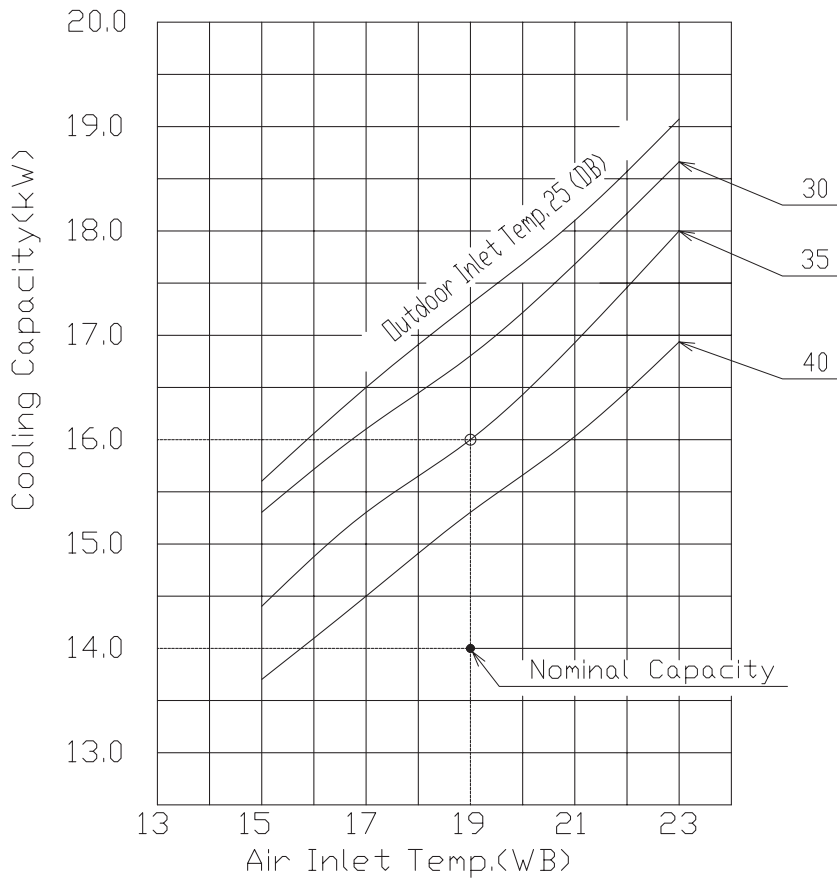

7S138315

◆ **RAS-8HNPE**

Cooling Capacity curves

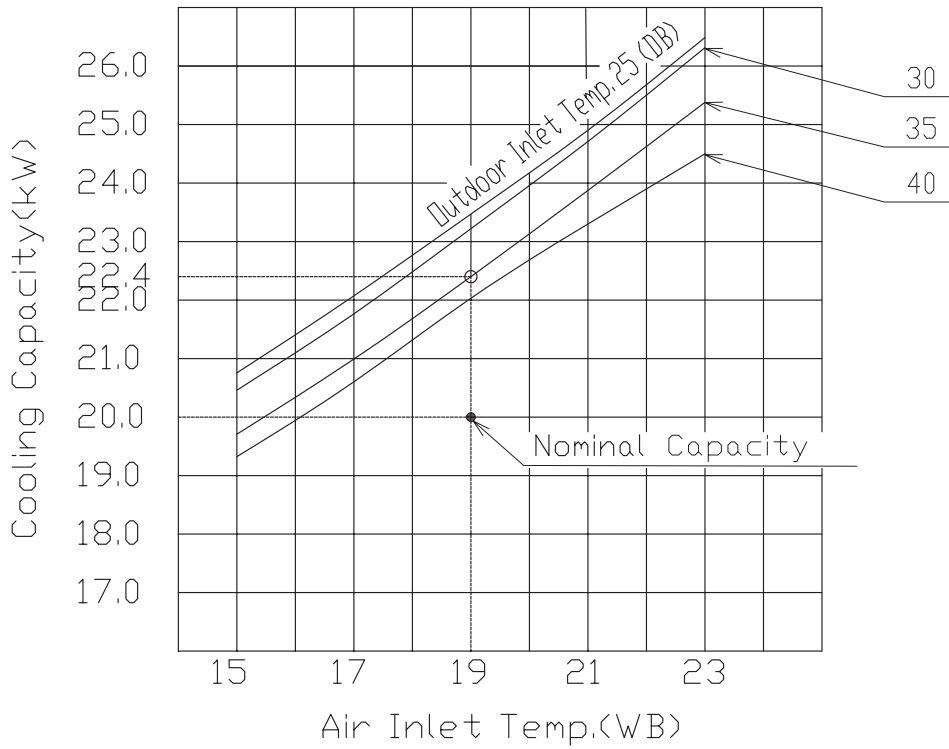

7S138468

◆ **RAS-10HNPE**

Cooling Capacity curves

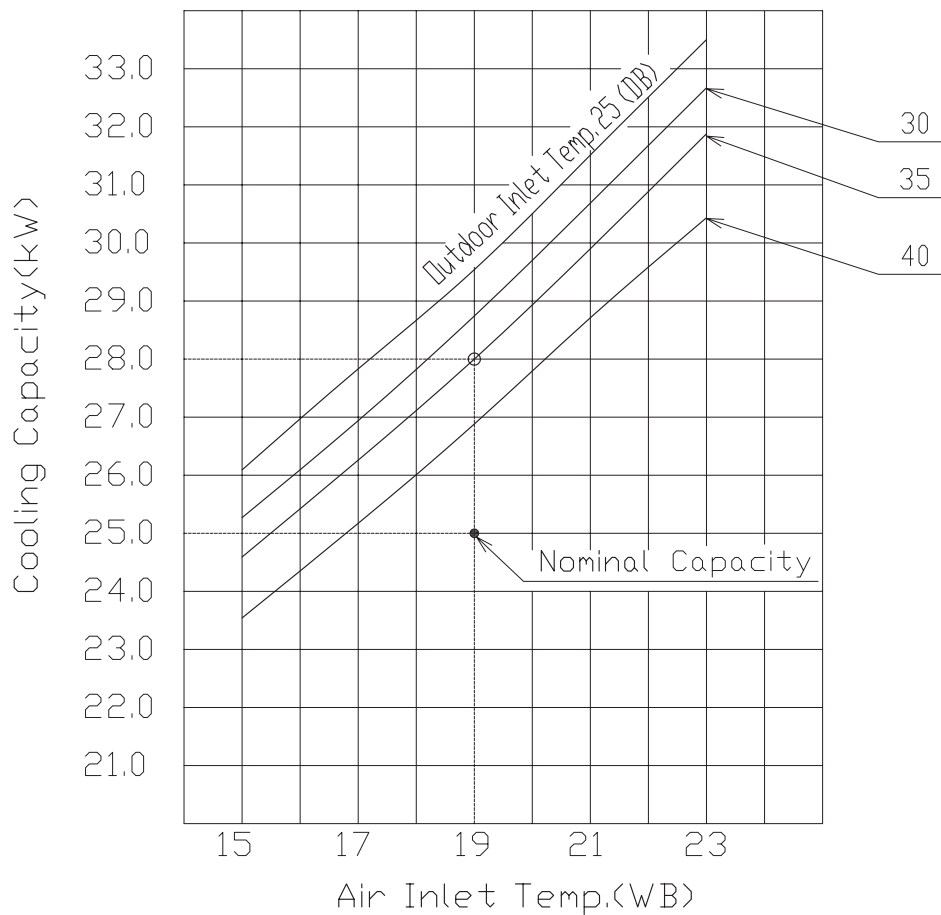

7S138469

4

◆ **RAS-12HNP**

Cooling Capacity curves

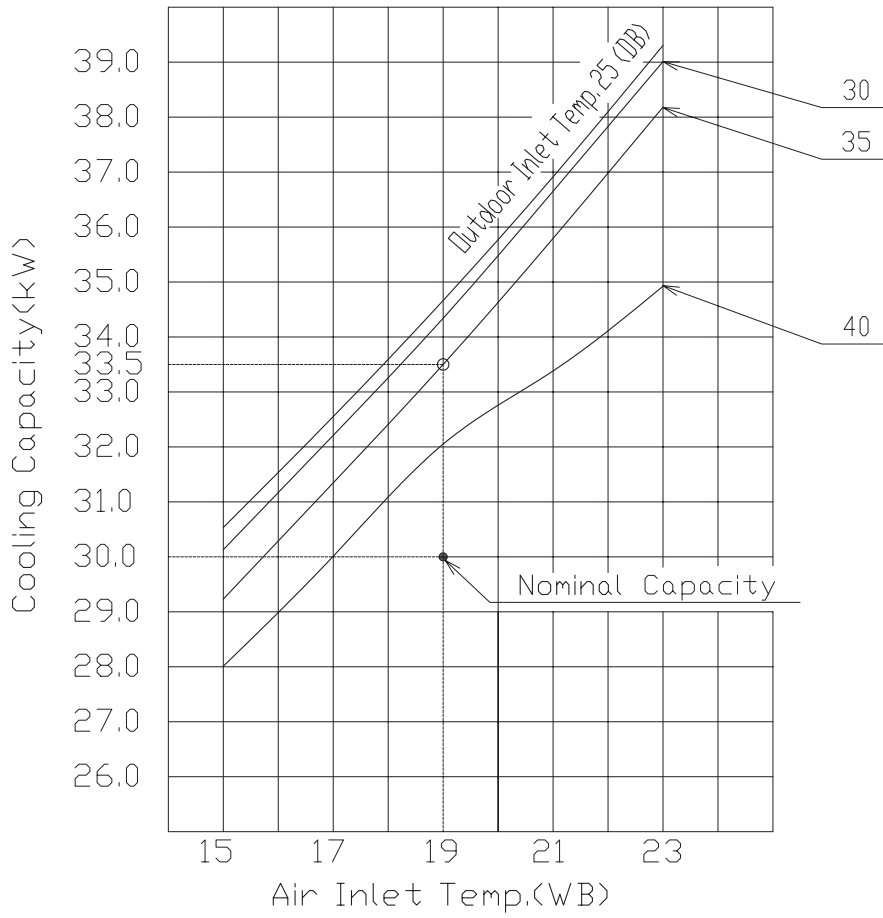

7S138470

4.3.2 IVX Standard series

◆ **RAS-3HVNC**

Cooling Capacity curves

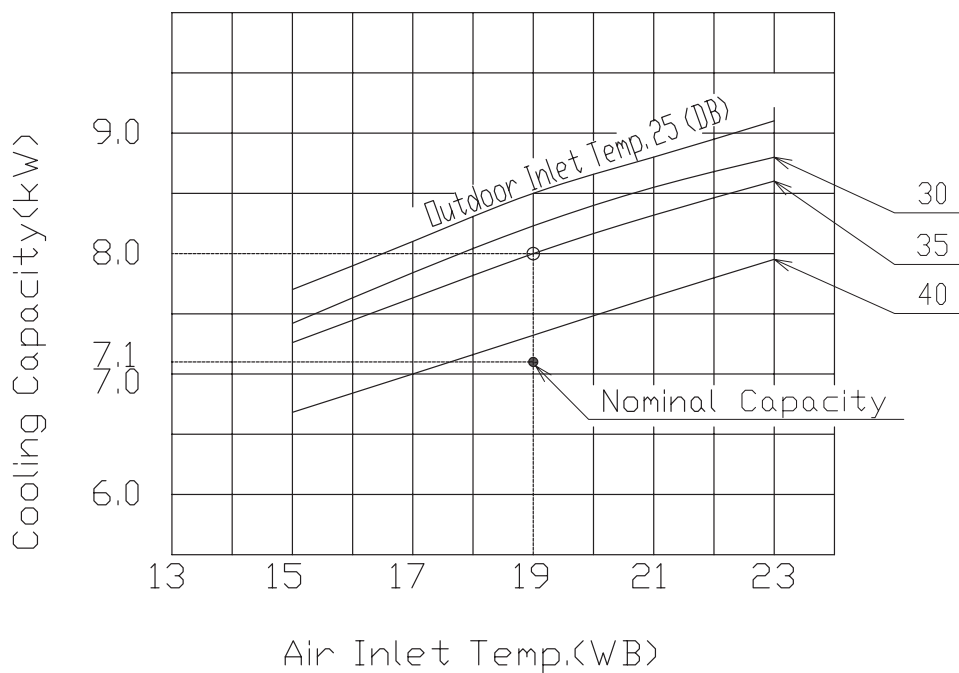

7S139311

◆ **RAS-4H(V)NCE**

Cooling Capacity curves

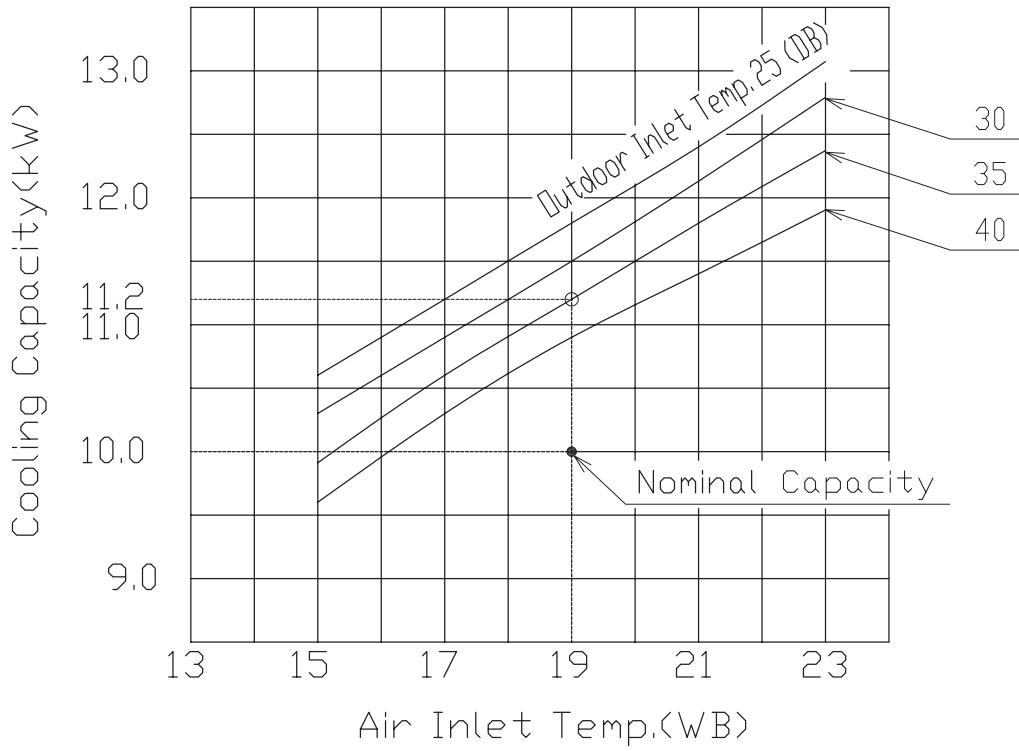

7S138477

◆ **RAS-5H(V)NCE**

Cooling Capacity curves

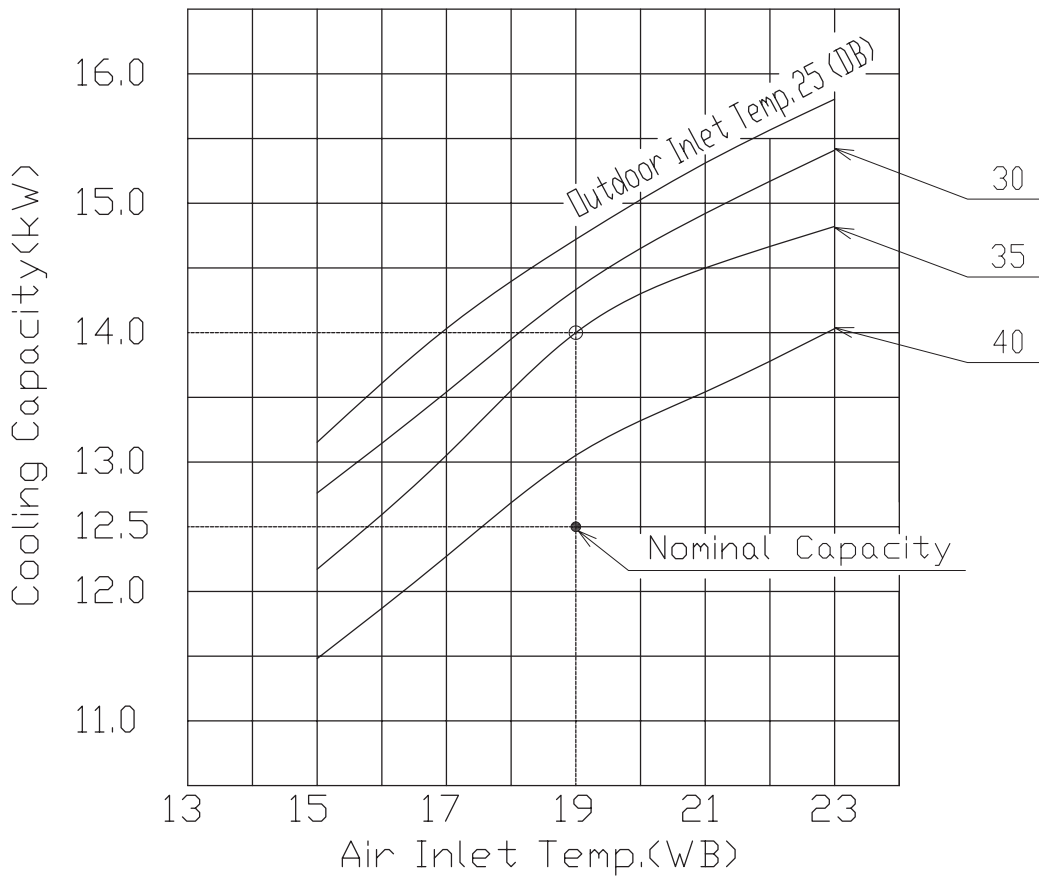

7S138478

4

◆ **RAS-6H(V)NCE**

Cooling Capacity curves

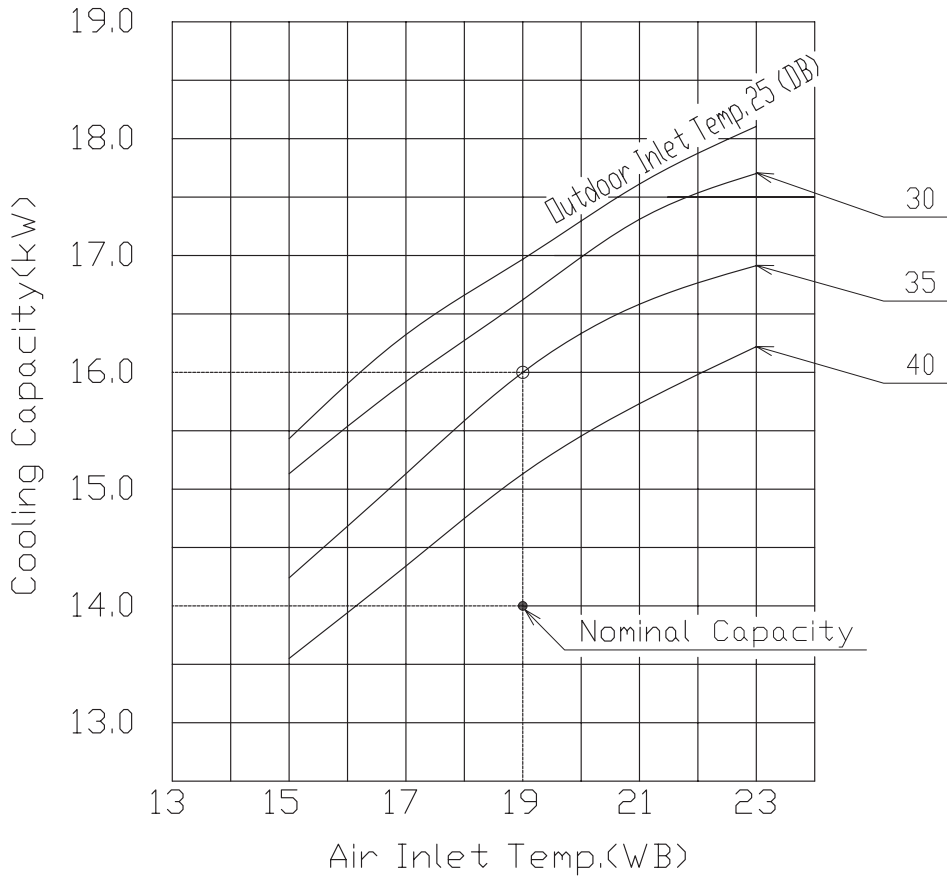

7S138479

◆ **RAS-8HNCE**

Cooling Capacity curves

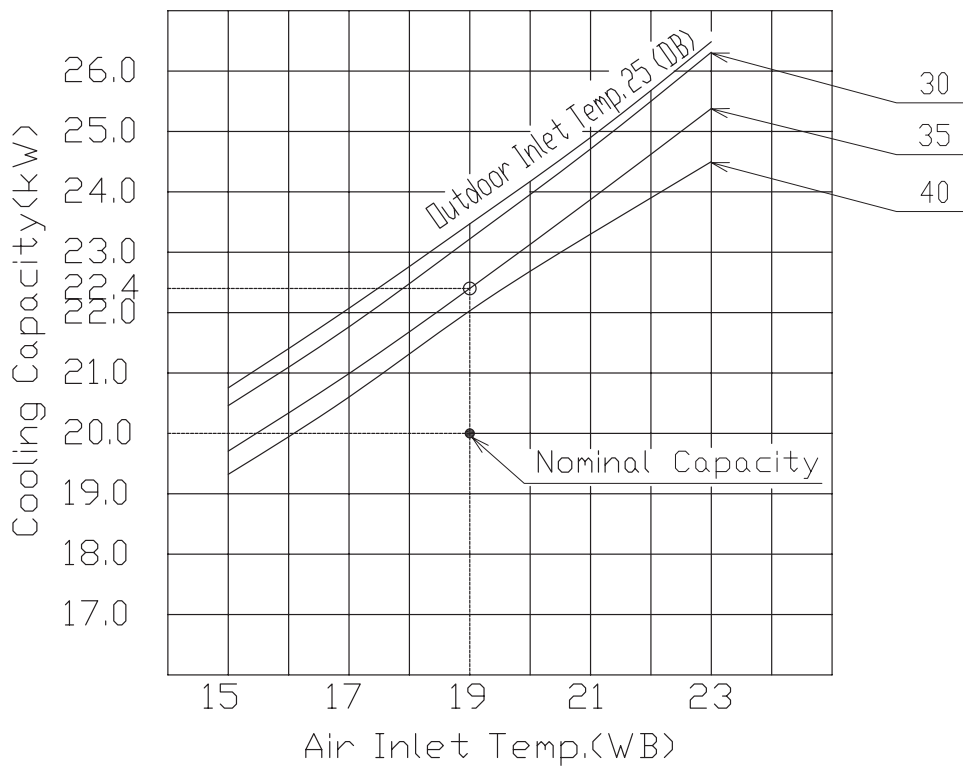

7S136544

◆ **RAS-10HNCE**

Cooling Capacity curves

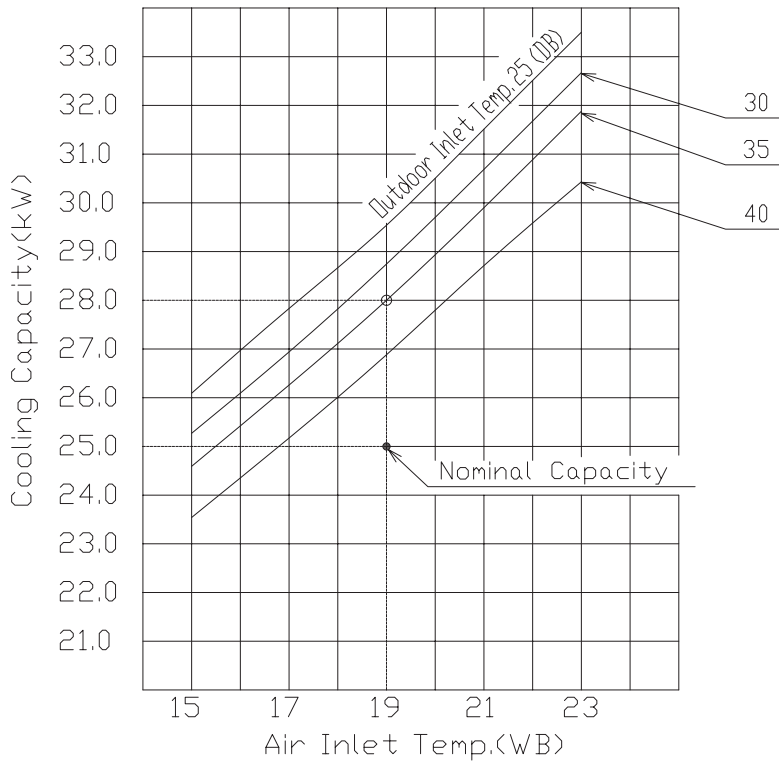

7S136545

◆ **RAS-12HNC**

Cooling Capacity curves

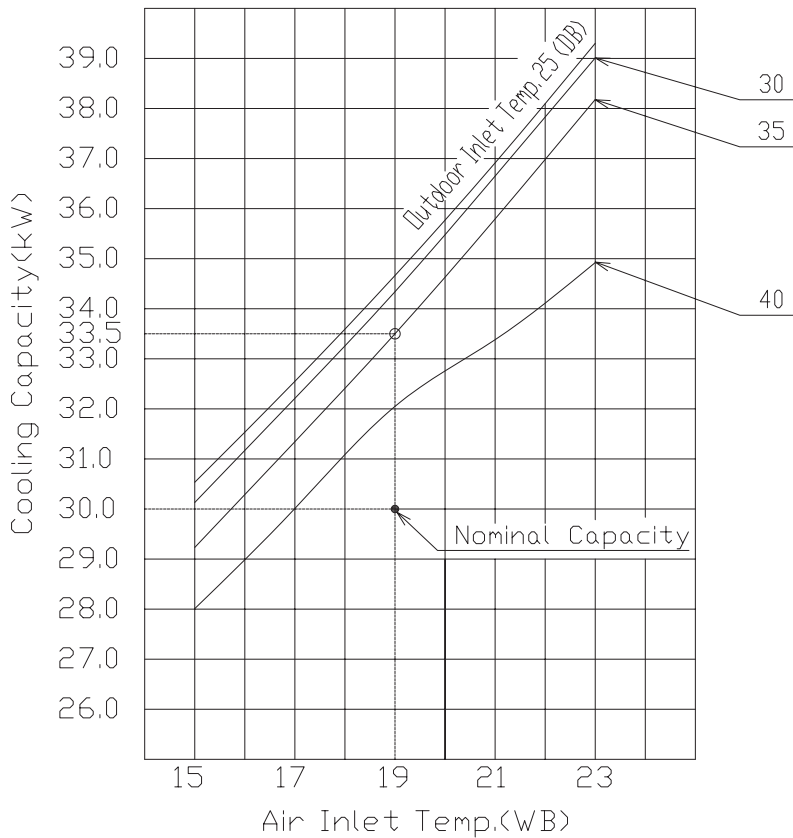

7S136546

4.4 Maximum heating capacity curve

Curves are based on the following conditions:

Piping Length/Height difference: 7.5 m / 0 m

The point "o" on the curves is based on the following conditions:

Indoor air inlet temperature: 20°C (DB)

Outdoor air inlet temperature: 7°C (DB) / 6°C (WB)

The curves are based on High speed of indoor fan. to calculate the cooling capacity of medium or low speed of indoor fan, multiply cooling capacity of high speed by correction curve factor.

The curve does not include decreasing capacity by defrosting operation.

All temperatures in °C.

4.4.1 IVX Premium series

◆ RAS-2HVNP

Heating Capacity curves

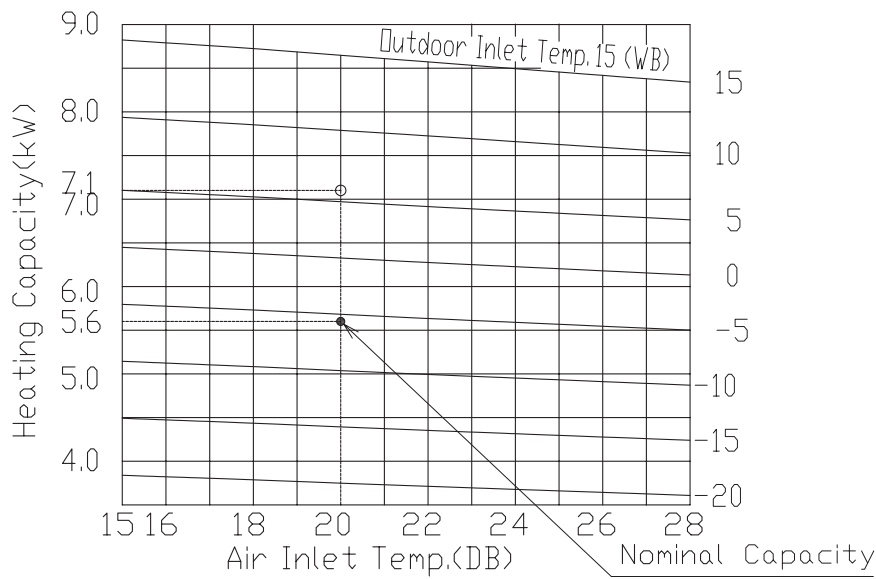

7S139312

◆ RAS-2.5HVNP

Heating Capacity curves

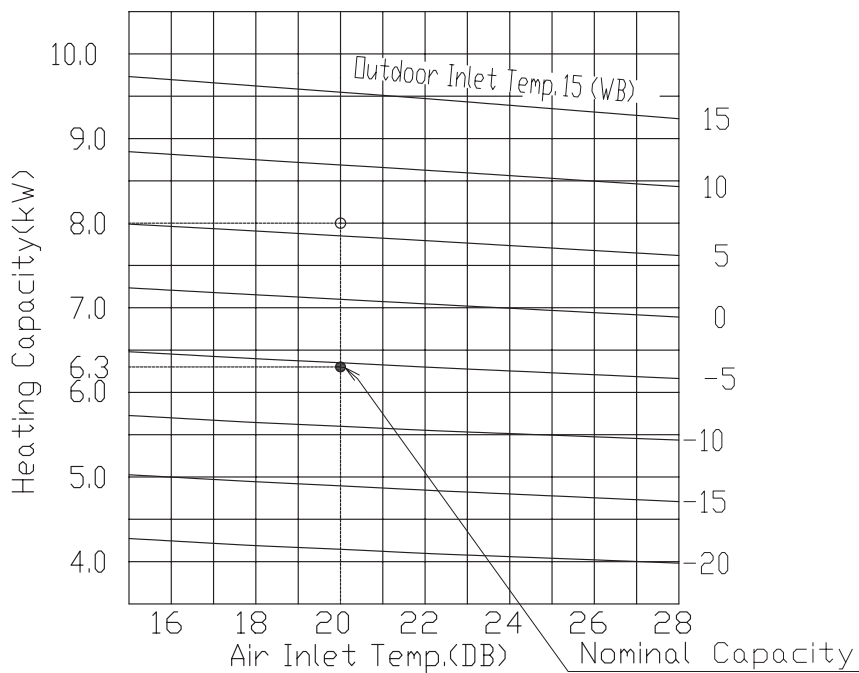

7S138313

◆ **RAS-3HVNPE**

Heating Capacity curves

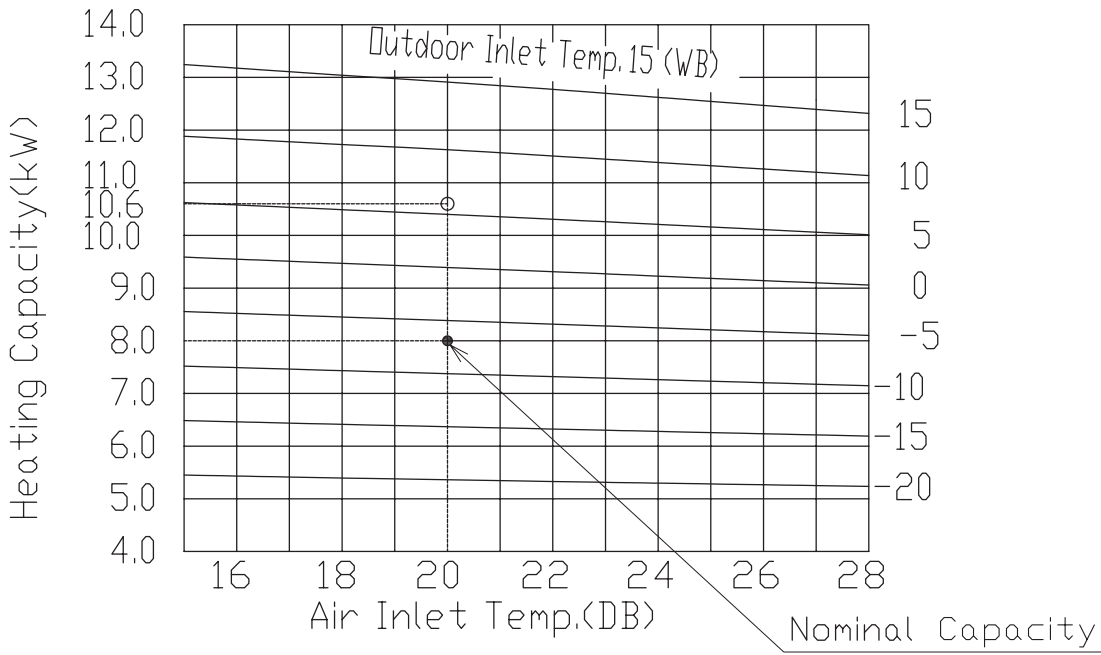

7S138317

◆ **RAS-4H(V)NPE**

Heating Capacity curves

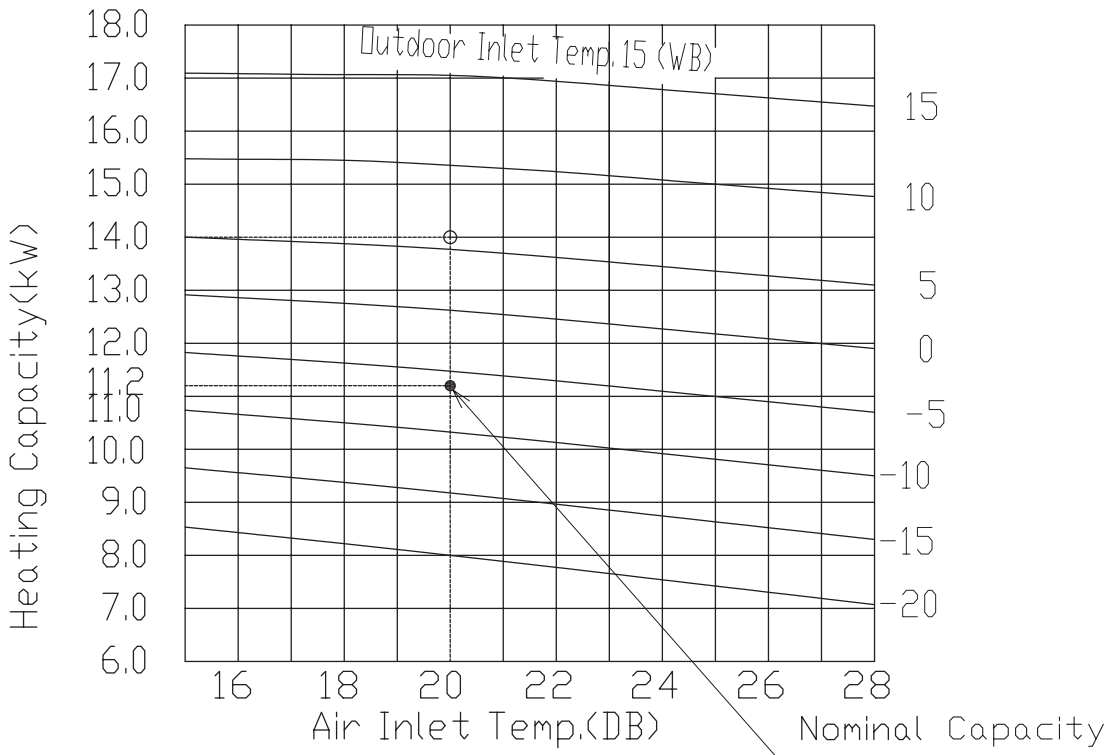

7S138318

4

◆ **RAS-5H(V)NPE**

Heating Capacity curves

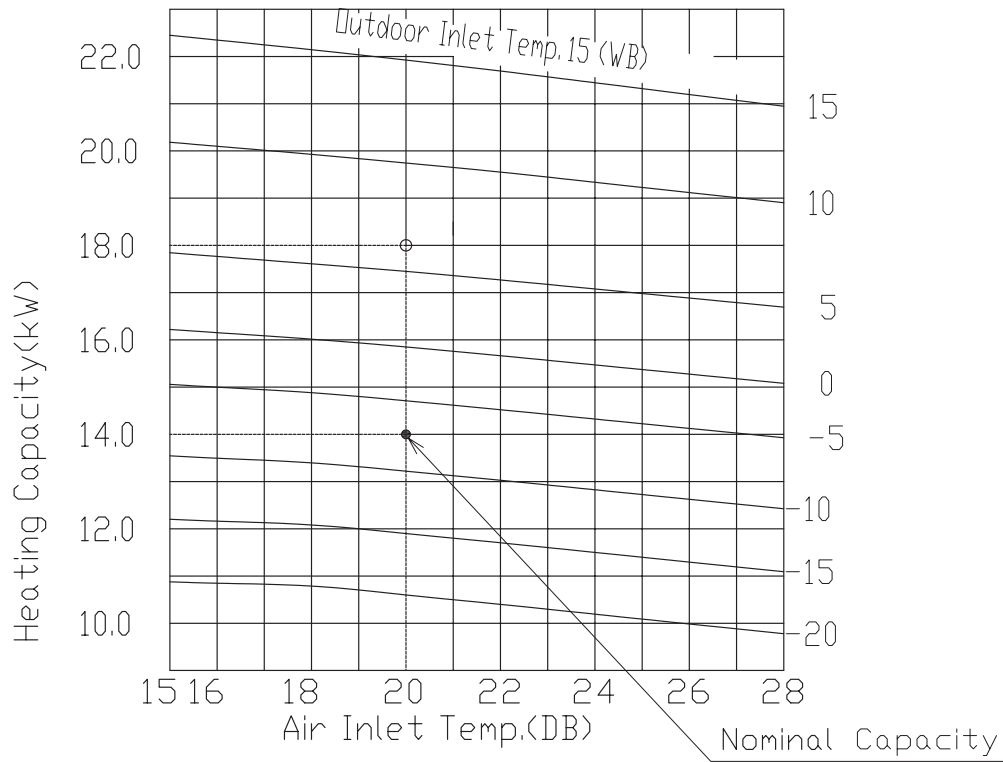

7S138319

◆ **RAS-6H(V)NPE**

Heating Capacity curves

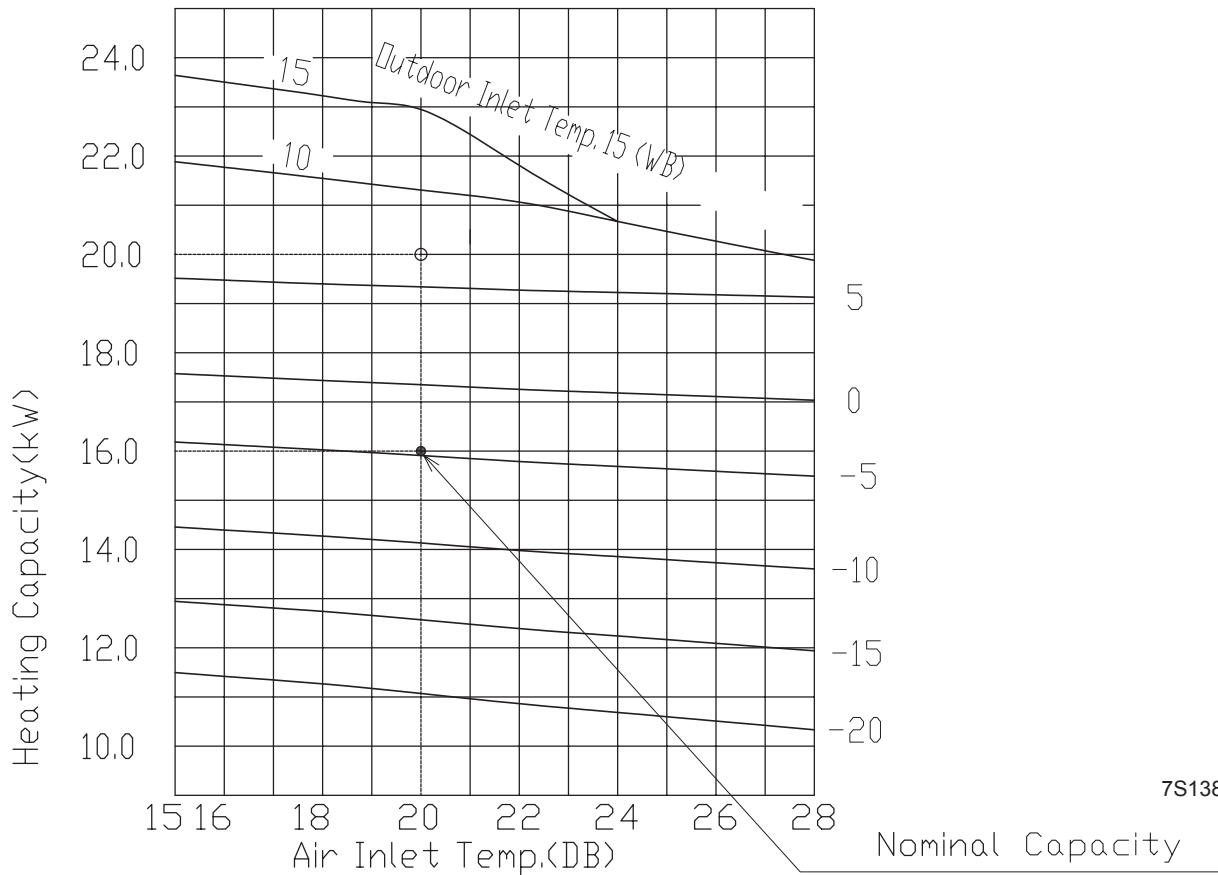

7S138320

◆ **RAS-8HNPE**

Heating Capacity curves

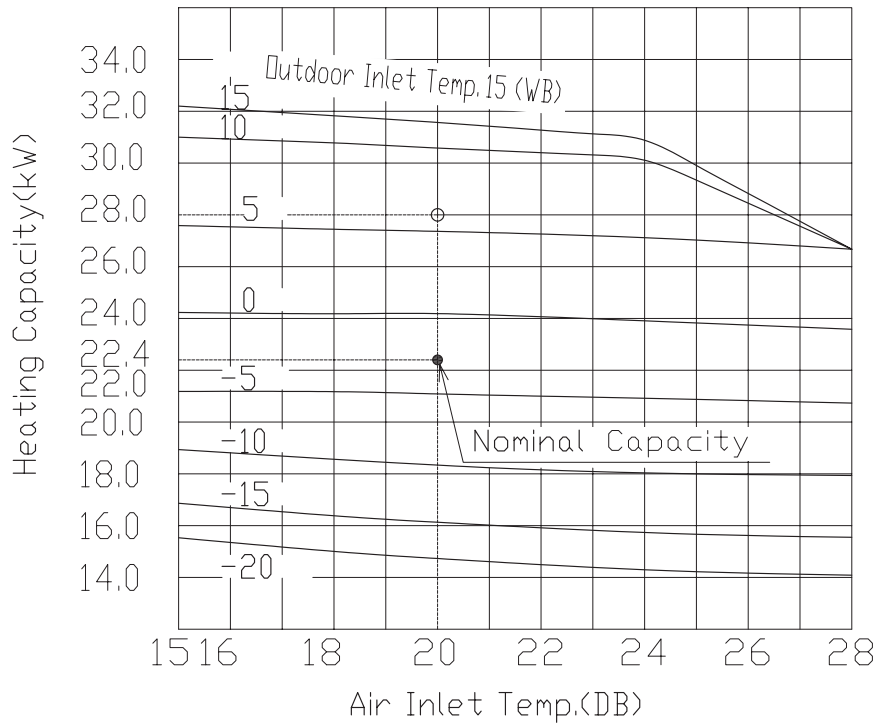

7S136520

◆ **RAS-10HNPE**

Heating Capacity curves

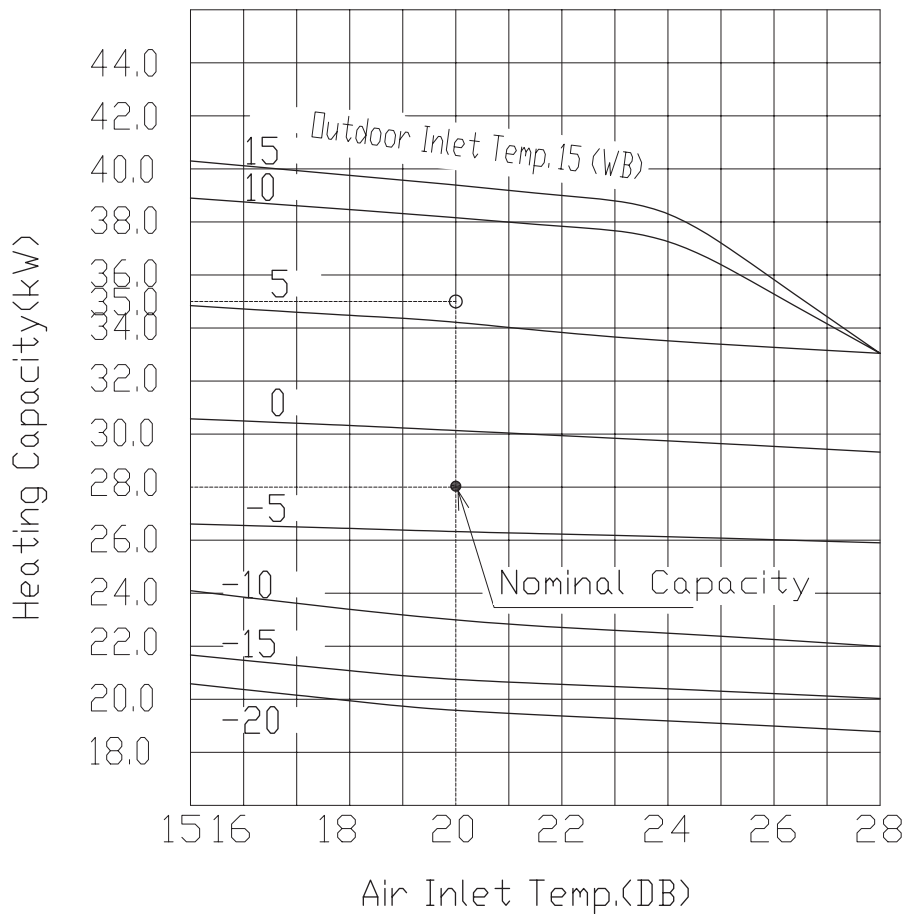

7S136521

◆ **RAS-12HNP**

Heating Capacity curves

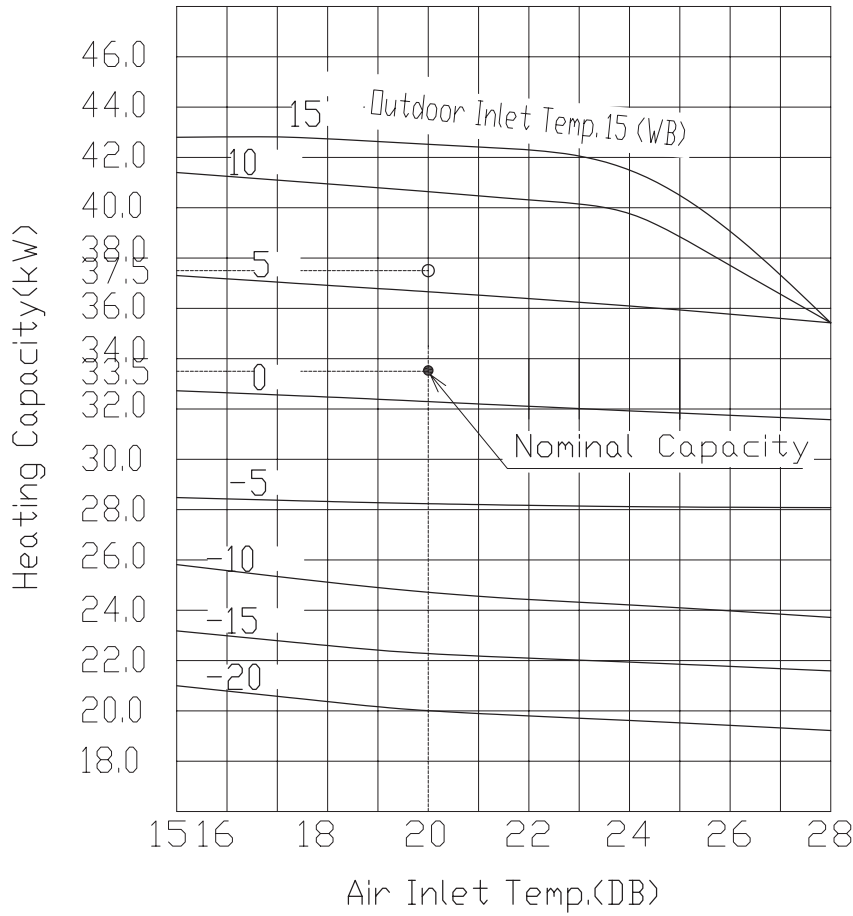

7S136522

4.4.2 IVX Standard series

◆ **RAS-3HVNC**

Heating Capacity curves

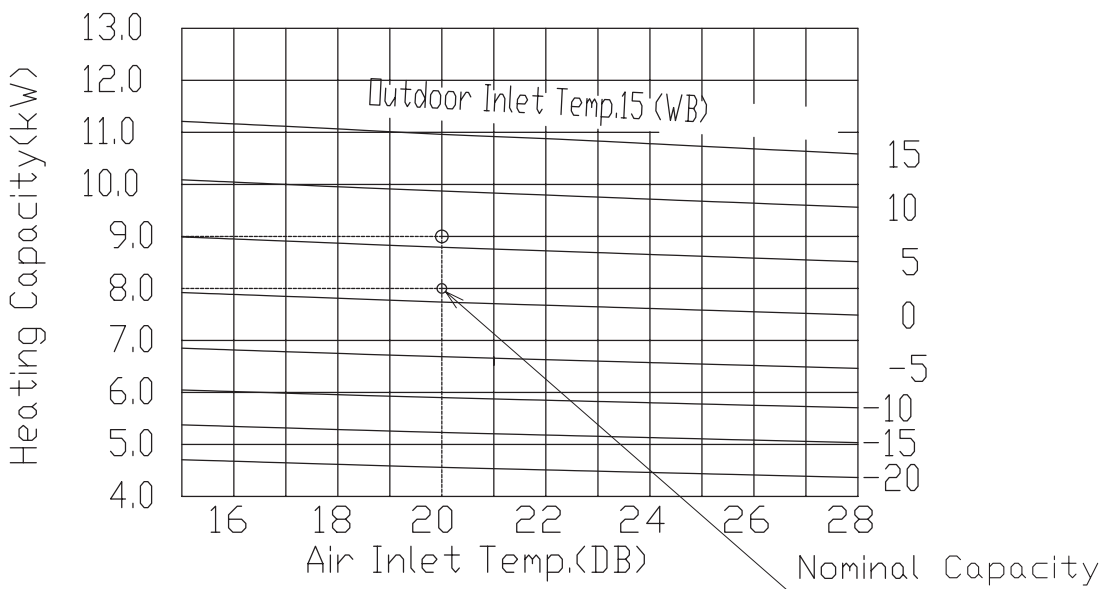

7S139316

◆ **RAS-4H(V)NCE**

Heating Capacity curves

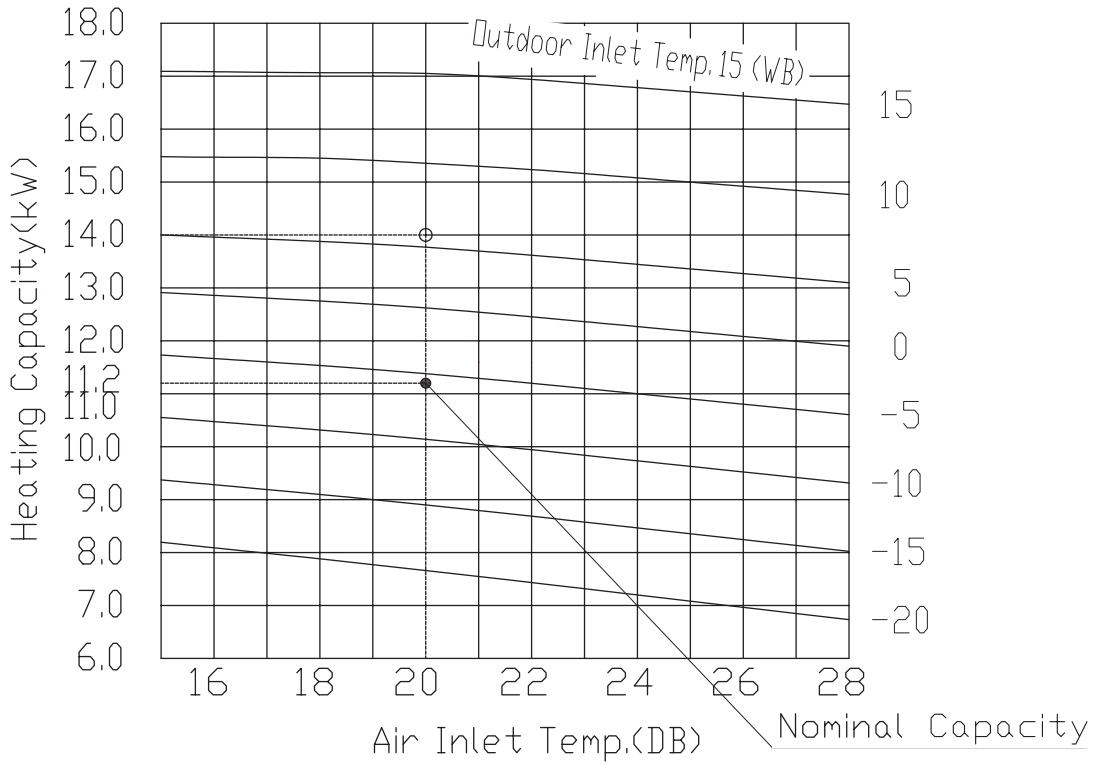

7S136553

◆ **RAS-5H(V)NCE**

Heating Capacity curves

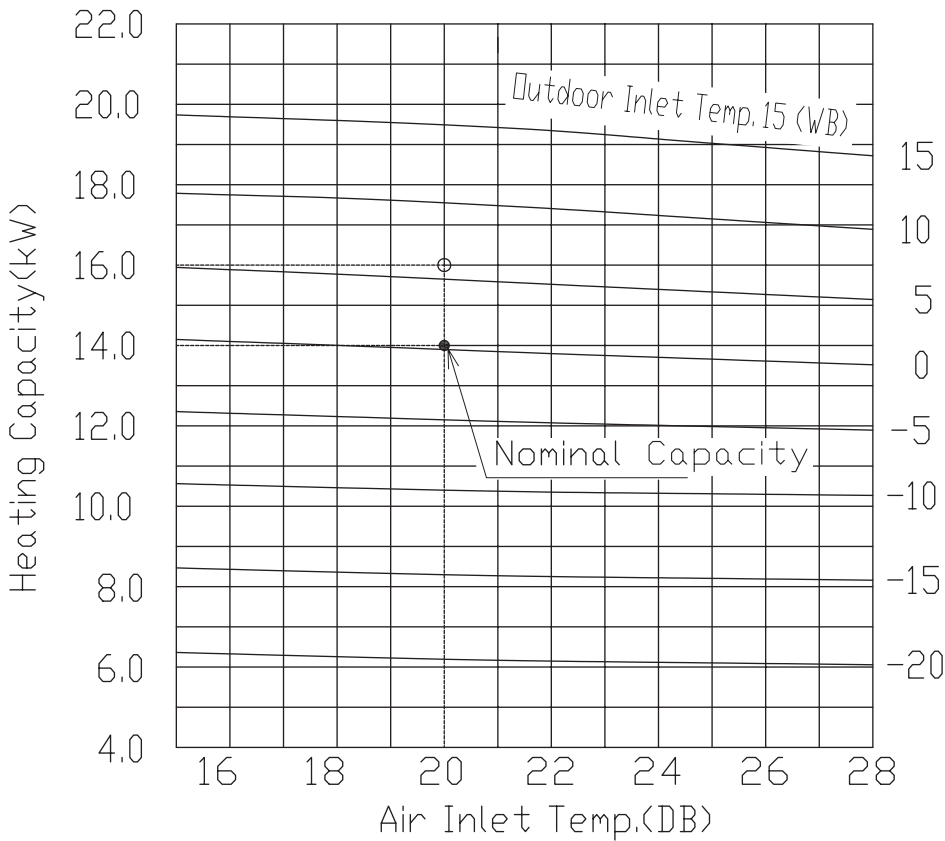

7S136554

◆ **RAS-6H(V)NCE**

Heating Capacity curves

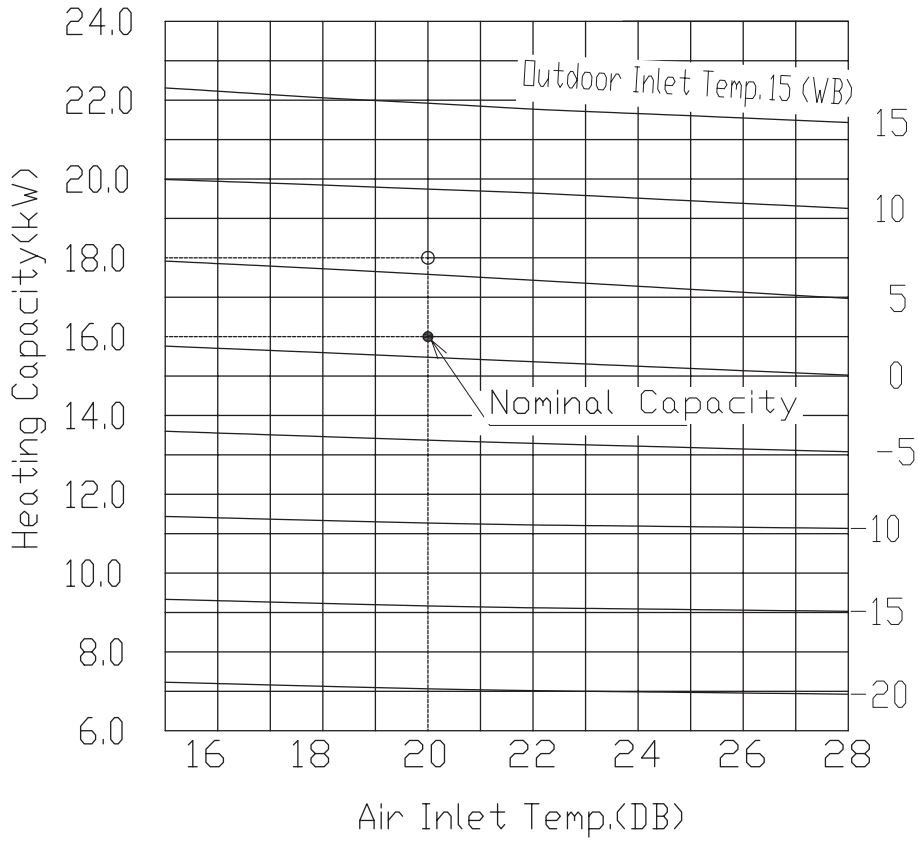

7S136555

◆ **RAS-8HNCE**

Heating Capacity curves

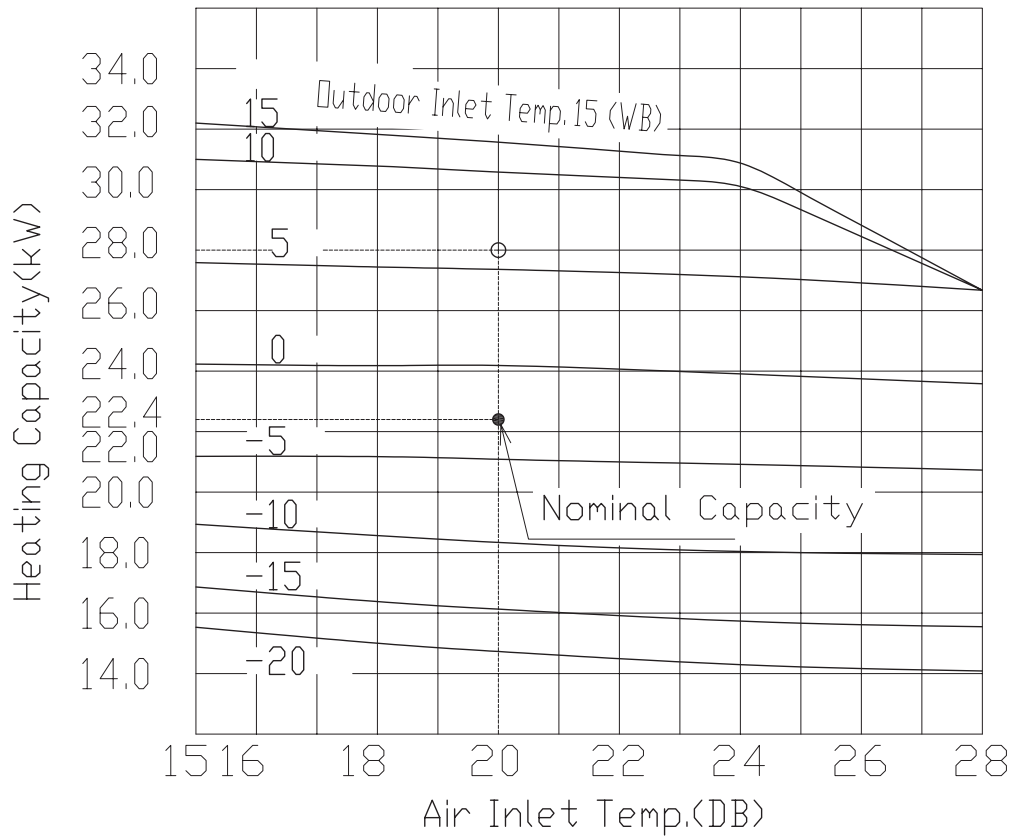

7S136556

◆ **RAS-10HNC**

Heating Capacity curves

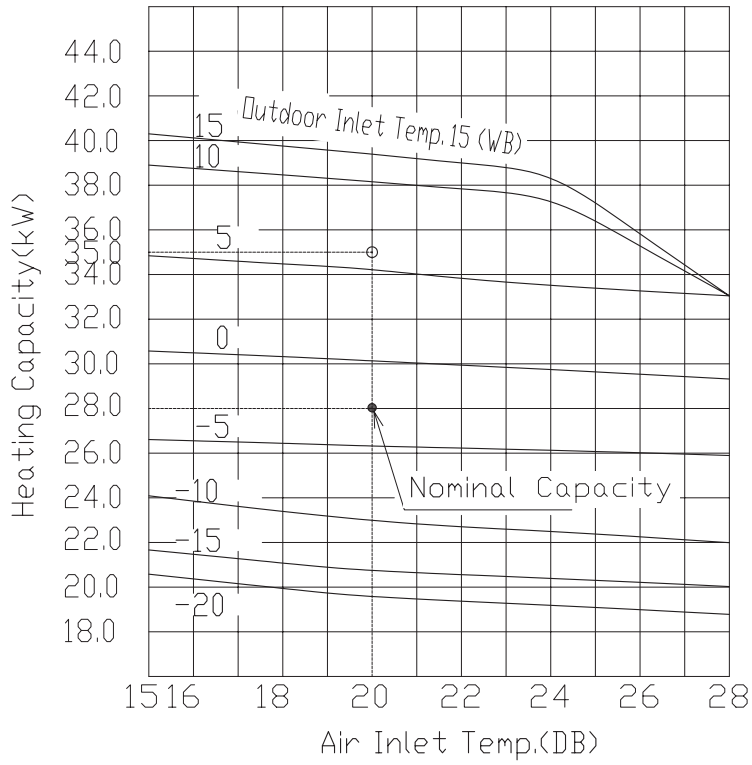

7S136557

◆ **RAS-12HNC**

Heating Capacity curves

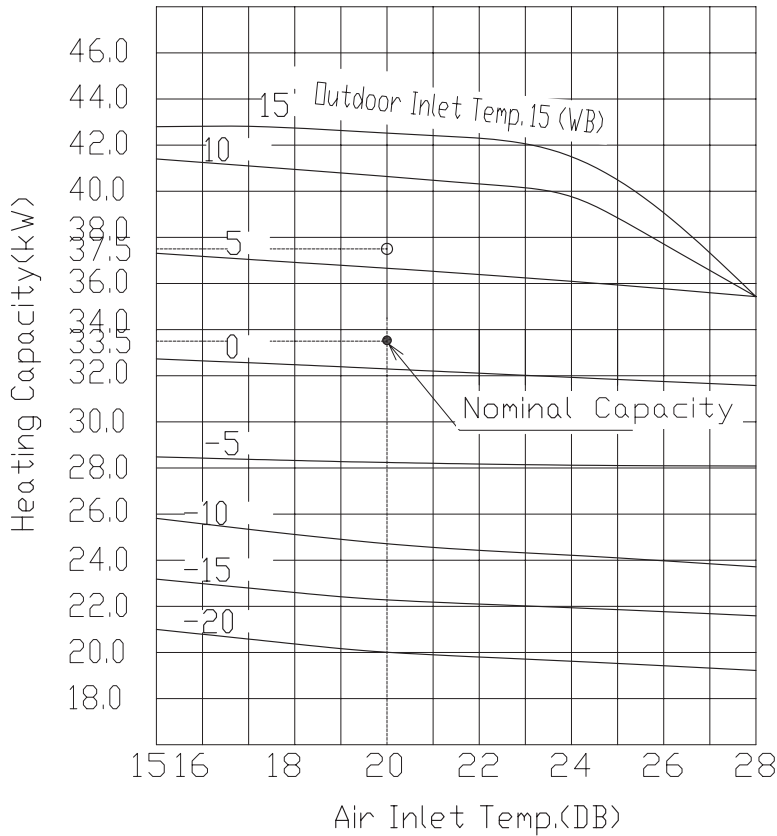

7S136558

4.5 Correction curve factor

4.5.1 Cooling

The curves are based on High speed of indoor fan. To calculate the cooling capacity of medium or low speed of indoor fan, multiply cooling capacity of high speed by correction curve factor.

Indoor Unit fan speed	Outdoor Unit HP		
	2 - 6	8	10/12
High	1.00	1.00	1.00
Medium	0.98	0.94	0.94
Low	0.95	0.86	0.87

4.5.2 Heating

The curves are based on High speed of indoor fan. to calculate the cooling capacity of medium or low speed of indoor fan, multiply cooling capacity of high speed by correction curve factor.

The curve does not include decreasing capacity by defrosting operation.

Indoor Unit fan speed	Outdoor Unit HP		
	2 - 6	8	10/12
High	1.00	1.00	1.00
Medium	0.98	0.86	0.86
Low	0.97	0.77	0.76

4.6 Piping length correction factor

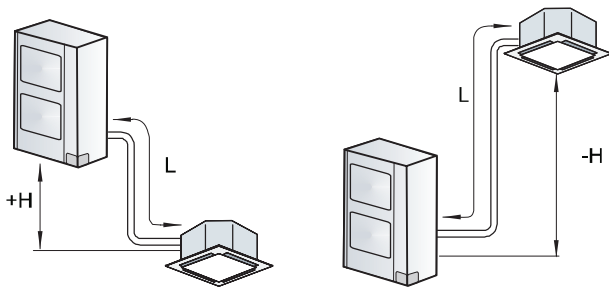

The correction factor is based on the equivalent piping length in meters (EL) and the height between outdoor and indoor units in meters (H).

H:

Height between indoor unit and outdoor unit (m).

- H>0: Position of outdoor unit is higher than position of indoor unit (m).
- H<0: Position of outdoor unit is lower than position of indoor unit (m).

L:

Actual one-way piping length between indoor unit and outdoor unit (m).

EL:

Equivalent one-way piping length between indoor unit and outdoor unit (m).

- One 90° elbow is 0.5 m.
- One 180° bend is 1.5 m.
- One Multi-kit is 0.5 m.



NOTE

In order to ensure correct unit selection, consider the farthest indoor unit.

4.6.1 IVX Premium series

Cooling

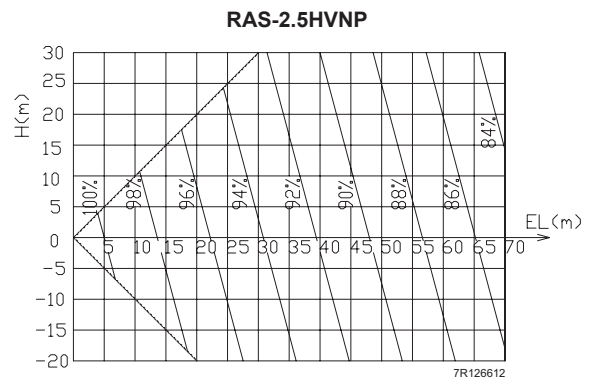
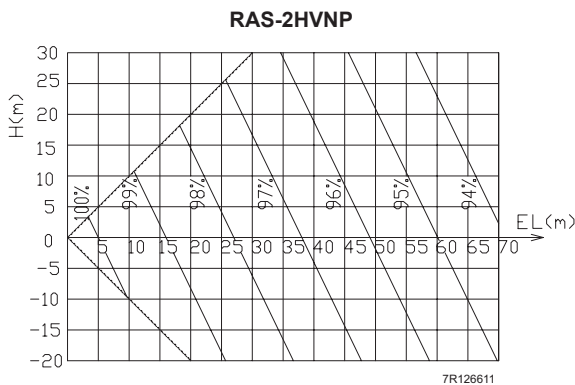

Cooling

RAS-3HVNP

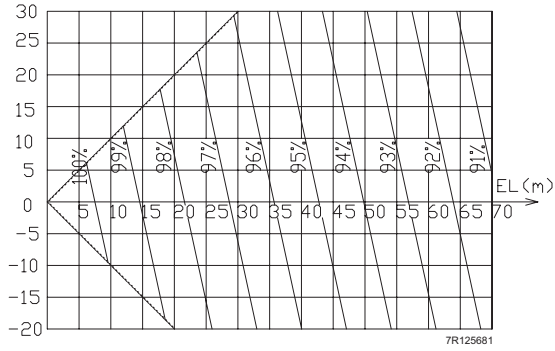

RAS-4H(V)NP

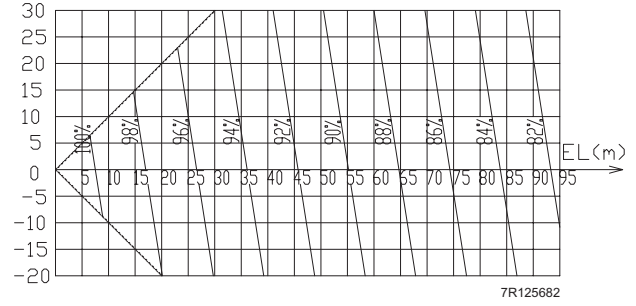

RAS-5H(V)NP

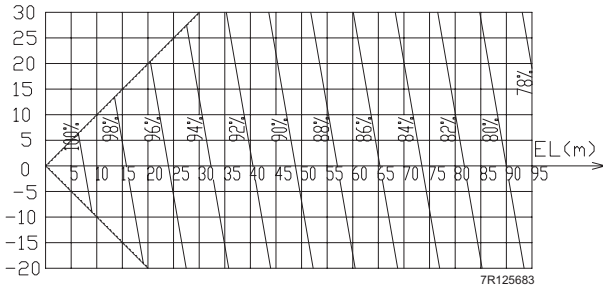

RAS-6H(V)NP

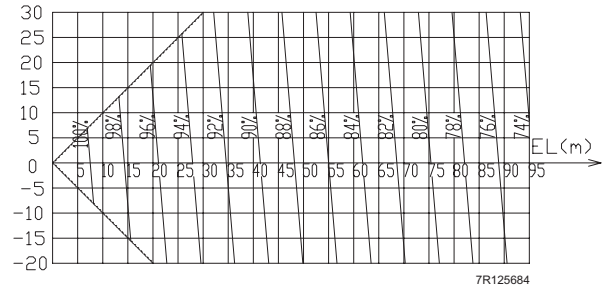

RAS-8HNP

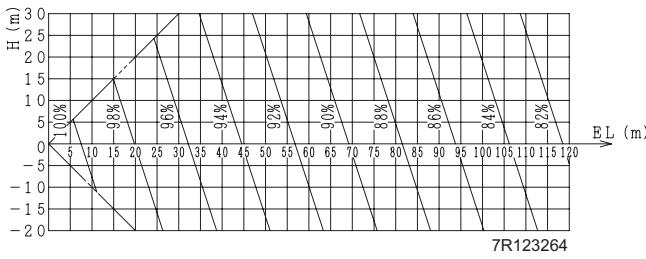

RAS-10HNP

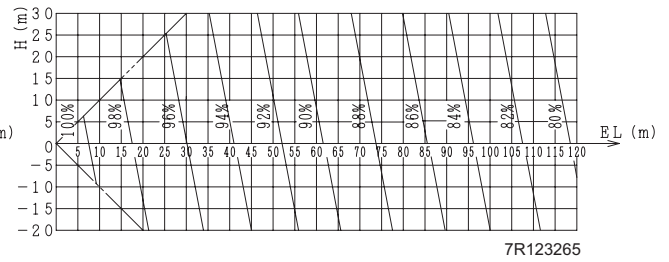

RAS-12HNP

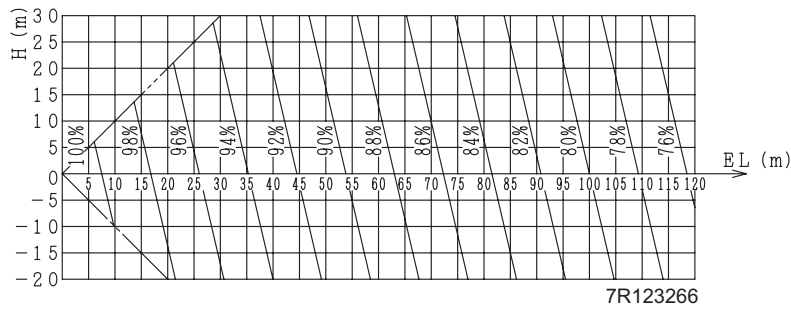

Heating

RAS-2HVNP

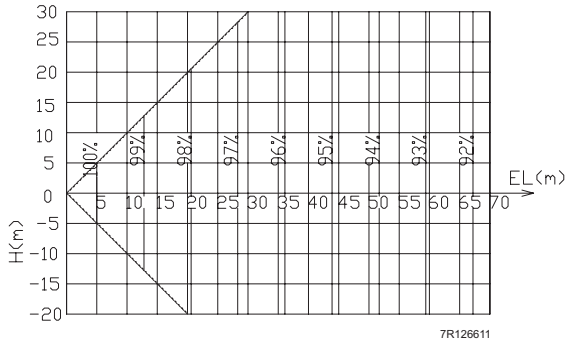

RAS-2.5HVNP

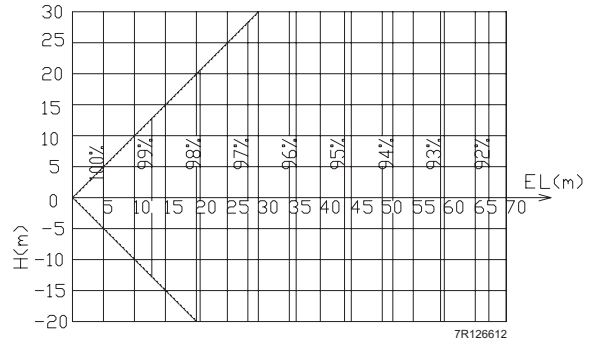

RAS-3HVNP

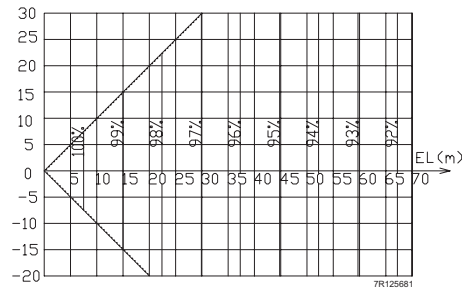

RAS-4H(V)NPE

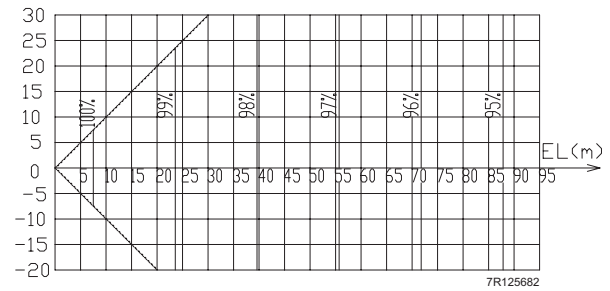

RAS-5H(V)NP

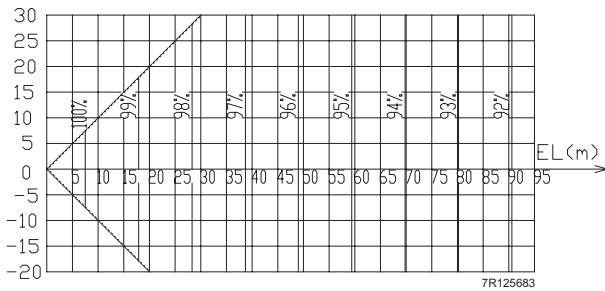

RAS-6H(V)NPE

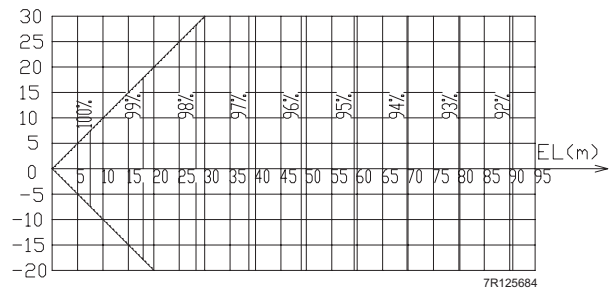

RAS-8HNPE

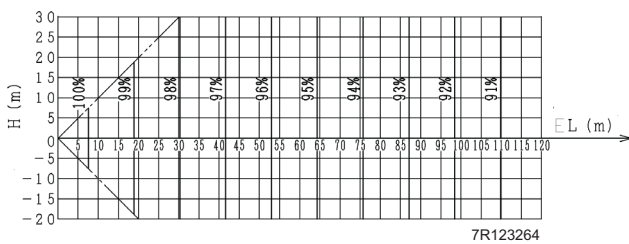

RAS-10HNPE

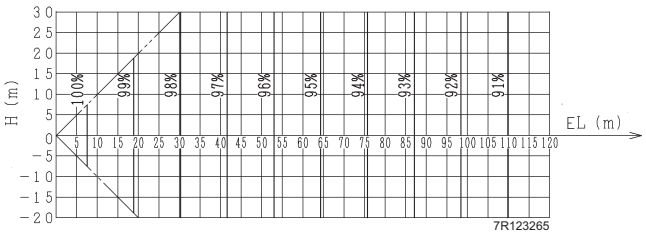

RAS-12HNPE

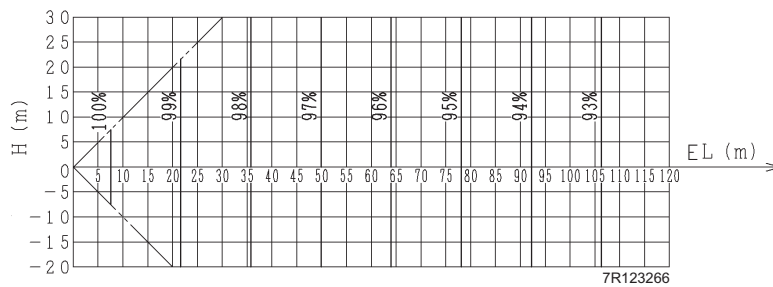

4.6.2 IVX Standard series

Cooling

RAS-3HVNC

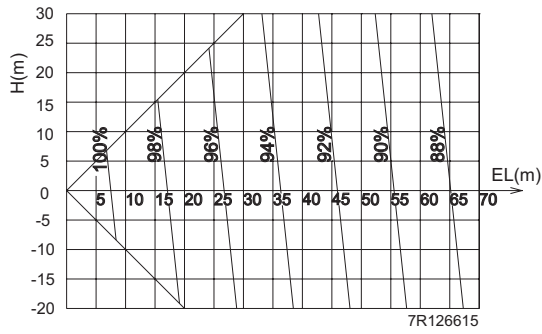

RAS-4H(V)NCE

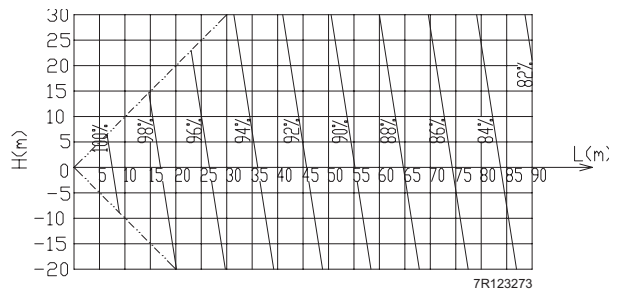

RAS-5H(V)NCE

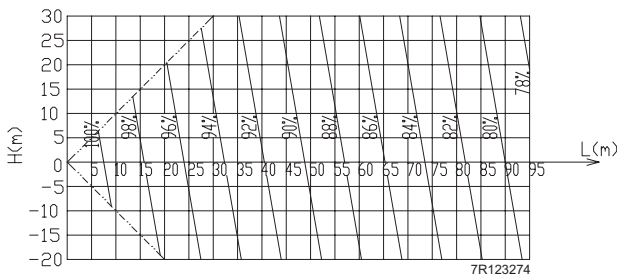

RAS-6H(V)NCE

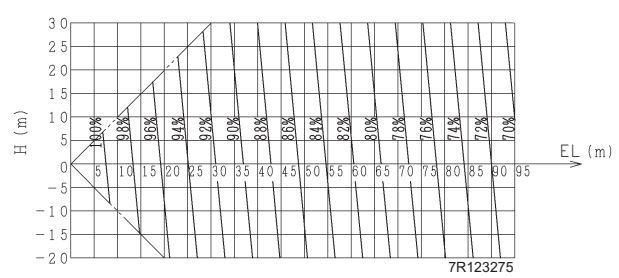

RAS-8HNCE

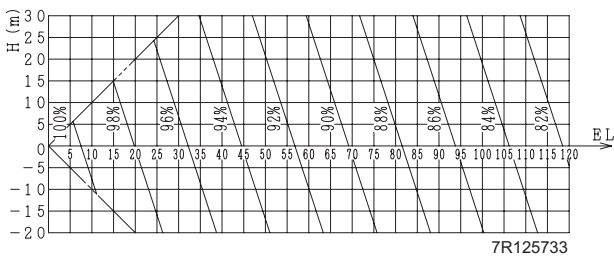

RAS-10HNCE

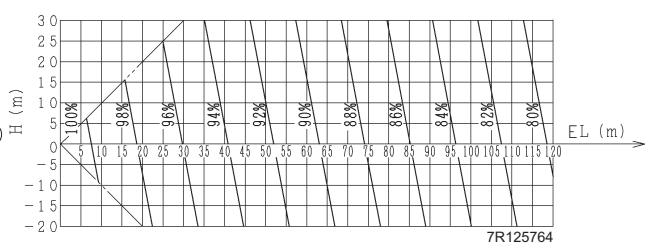

RAS-12HNC

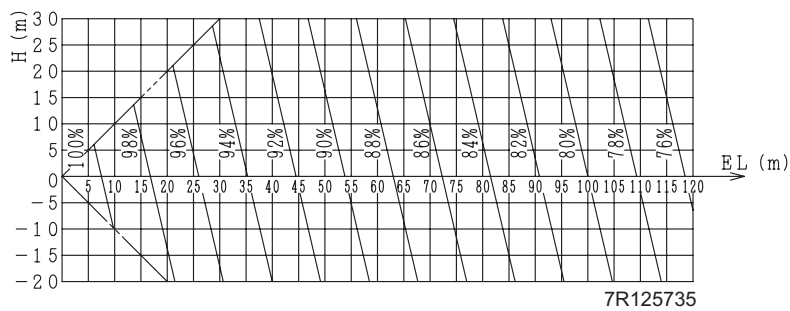

Heating

RAS-3HVNC

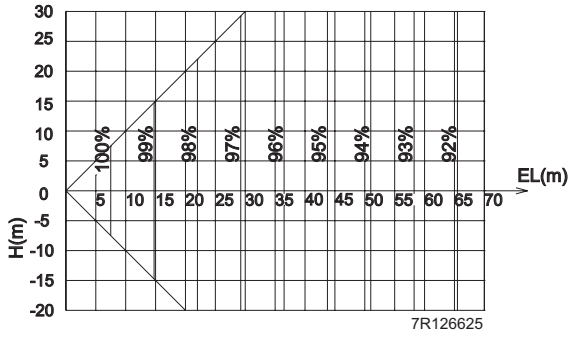

RAS-4H(V)CE

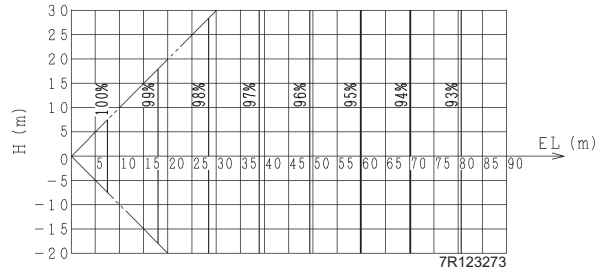

RAS-5H(V)NCE

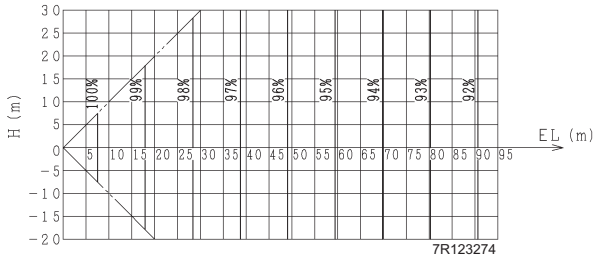

RAS-6H(V)NCE

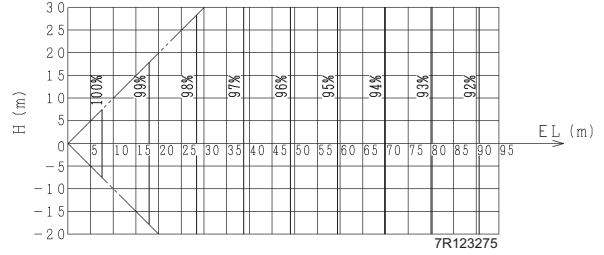

RAS-8HNCE

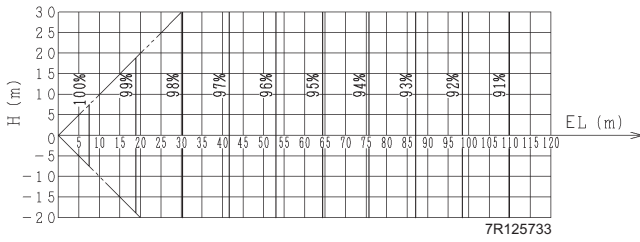

RAS-10HNCE

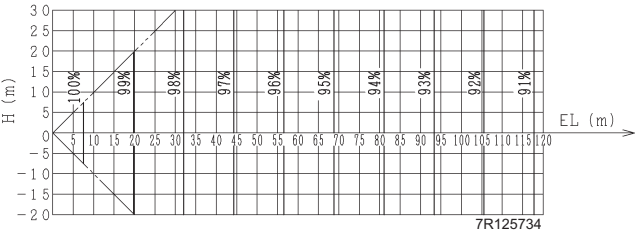

RAS-12HNC

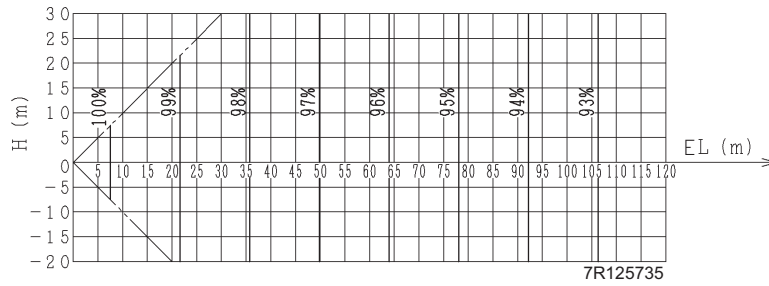

4.7 Correction factor / ratio

4.7.1 Defrost Operation correction factor

The heating capacity does not include operation during frost or defrosting.

When this type of operation is taken in account, the heating capacity must be corrected according to the following equation:

$$\text{Correction heating capacity} = \text{Correction factor} \times \text{heating capacity}$$



NOTE

- Defrost correction factor corresponds to a relative humidity of 85%. If the condition changes, the correction factor will be different.
- Defrost correction factor is not valid for special conditions such as during snow or operation in a transitional period.

Outdoor inlet air temp. (°C DB)	-7	-5	-3	0	3	5	7
Correction factor	0.95	0.93	0.88	0.85	0.87	0.90	1.00



NOTE

- Defrost correction factor corresponds to a relative humidity of 85%. If the condition changes, the correction factor will be different.
- Defrost correction factor is not valid for special conditions such as during snow or operation in a transitional period.

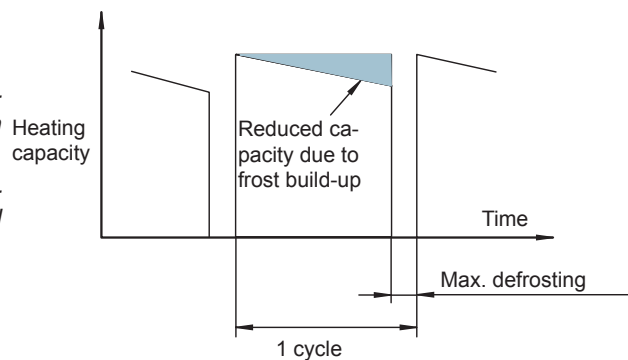

4.7.2 Correction ratio due to humidity (CR)

The cooling capacity data for the outdoor units is taken from the cooling capacity curves. The curves are calculated on the basis of a relative humidity of 50%.

In some situations, it's possible that the temperature condition of the ambient to be conditioned, specifies other different relative humidity, which affect at the Dry Bulb temperature. In this cases, it's necessary to calculate the difference between the indoor air inlet dry bulb temperature required by the system and the indoor air inlet dry bulb temperature shown in the cooling capacity data.

This temperature difference requires an adjustment of the cooling capacity of the system.

$$Q_{AC} = Q_C + (CR \times (DB_R - DB))$$

Model	CR
RAS-2HVNP	0.25
RAS-2.5HVNP	0.30
RAS-3HVN(P/C)E	0.34
RAS-4H(V)N(P/C)E	0.43
RAS-5H(V)N(P/C)E	0.51
RAS-6H(V)N(P/C)E	0.59
RAS-8HN(P/C)E	0.74
RAS-10HN(P/C)E	0.89
RAS-12HN(P/C)	1.01

5. Acoustic characteristic curves

Contents

5. Acoustic characteristic curves	77
5.1 Overall sound level.....	78
5.2 Sound pressure data.....	79
5.2.1 IVX Premium series.....	79
5.2.2 IVX Standard series.....	81

5

5.1 Overall sound level

The overall sound level has been measured in an anechoic chamber so reflected sound should be taken into consideration when installing the unit.

Test Conditions:

- 1 Distance of the unit from the measuring point: 1 meter from the unit's front surface; 1.5 meter from floor level:

Overall sound level measuring position

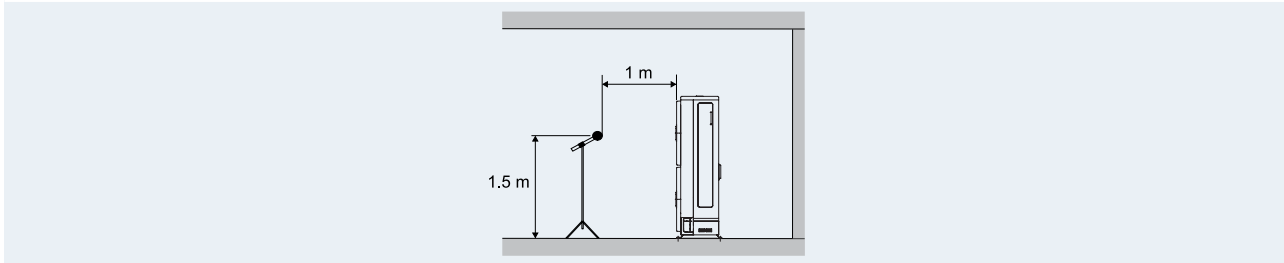

- 2 Power supply:

- a. Single phase units: 1~ 230V 50Hz.
- b. Three phase units: 3N~ 400V 50Hz.



NOTE

- *The sound data is measured in an anechoic chamber, so reflected sound should be taken into consideration when installing the unit.*

5.2 Sound pressure data

5.2.1 IVX Premium series

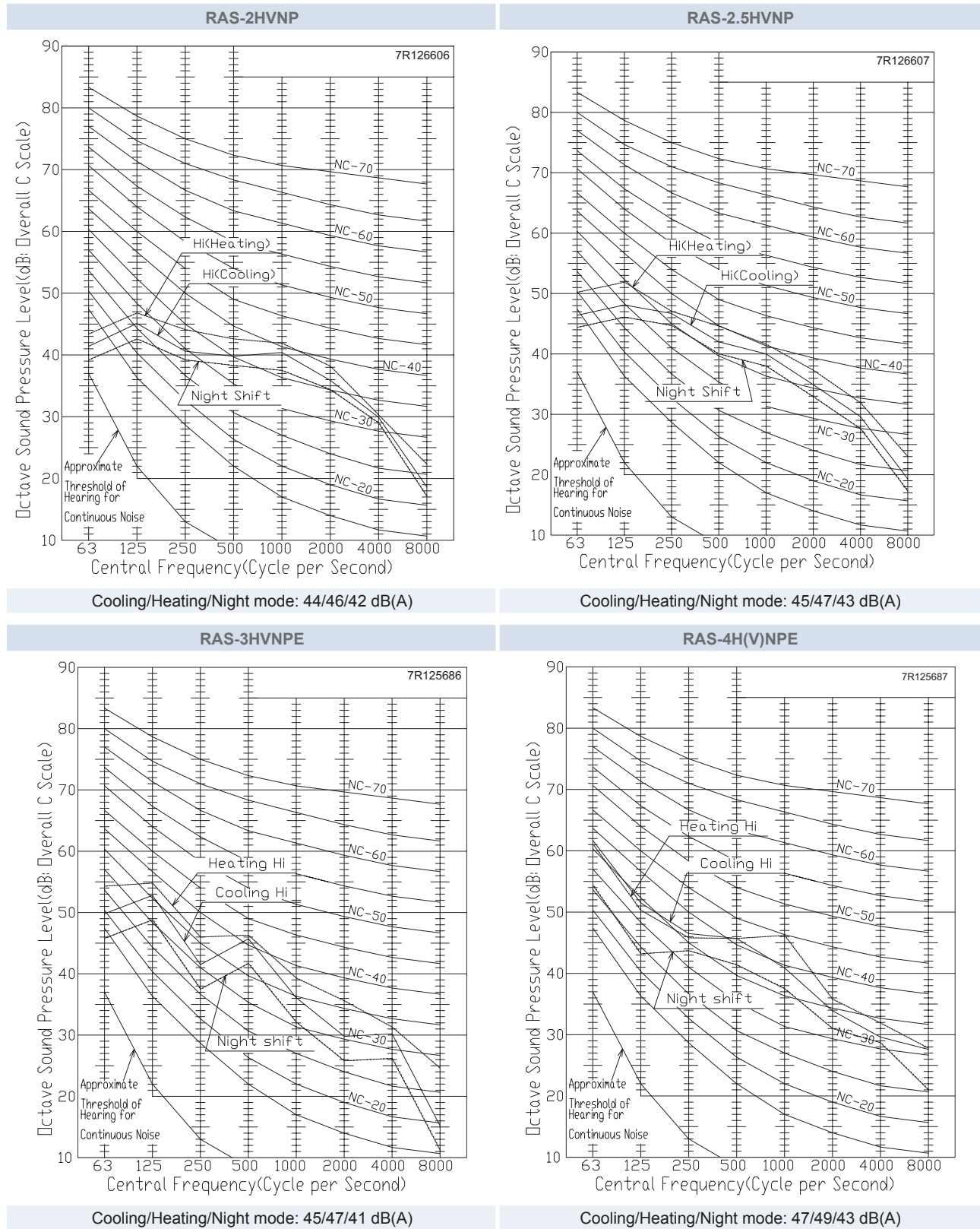

5

RAS-5H(V)NPE

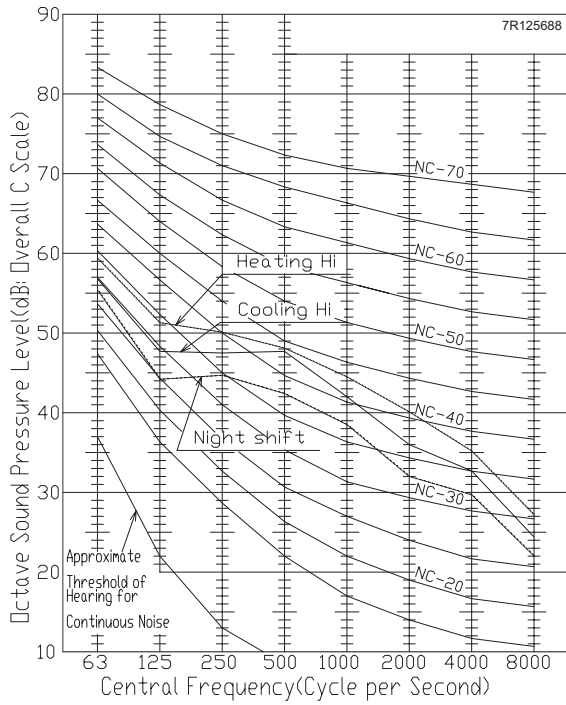

Cooling/Heating/Night mode: 48/50/44 dB(A)

RAS-6H(V)NPE

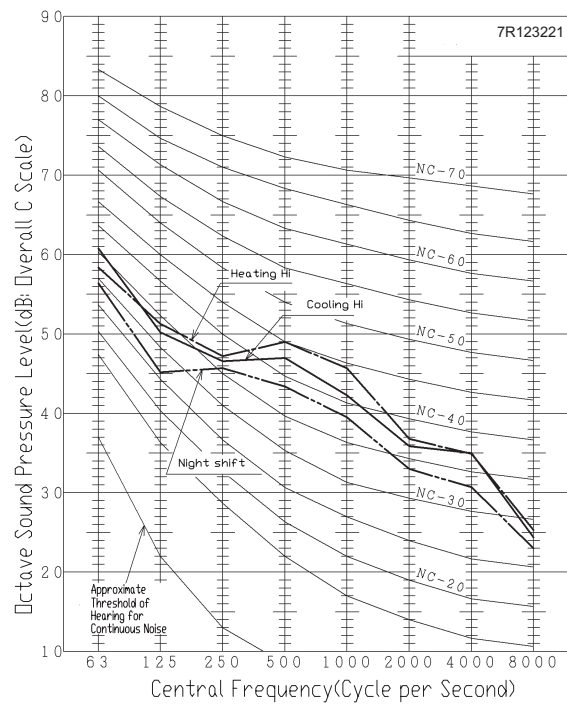

Cooling/Heating/Night mode: 48/50/45 dB(A)

RAS-8HNPE (Preliminary data)

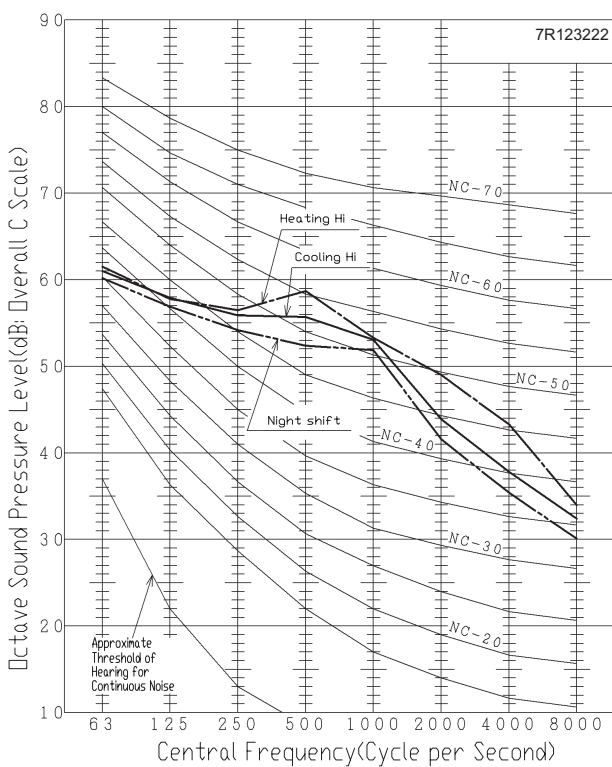

Cooling/Heating/Night mode: 57/59/55 dB(A)

RAS-10HNPE (Preliminary data)

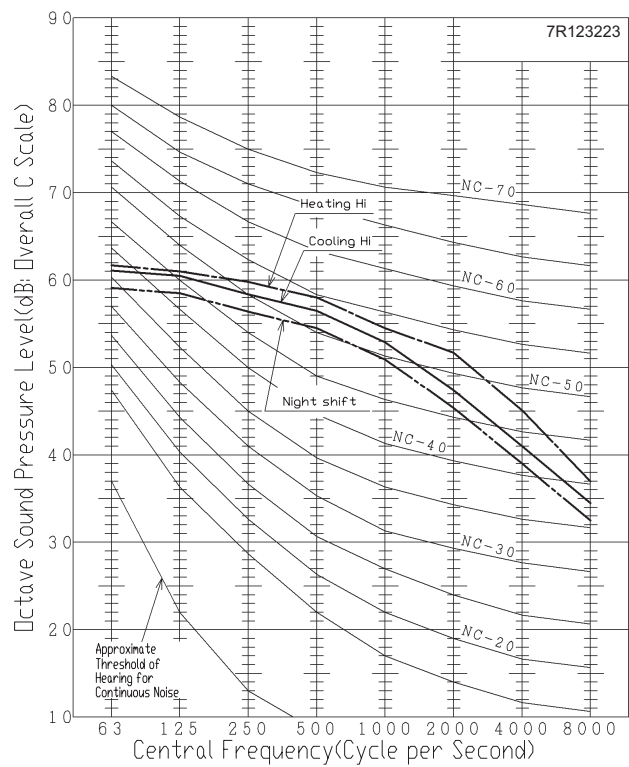

Cooling/Heating/Night mode: 58/60/56 dB(A)

RAS-12HNP (Preliminary data)

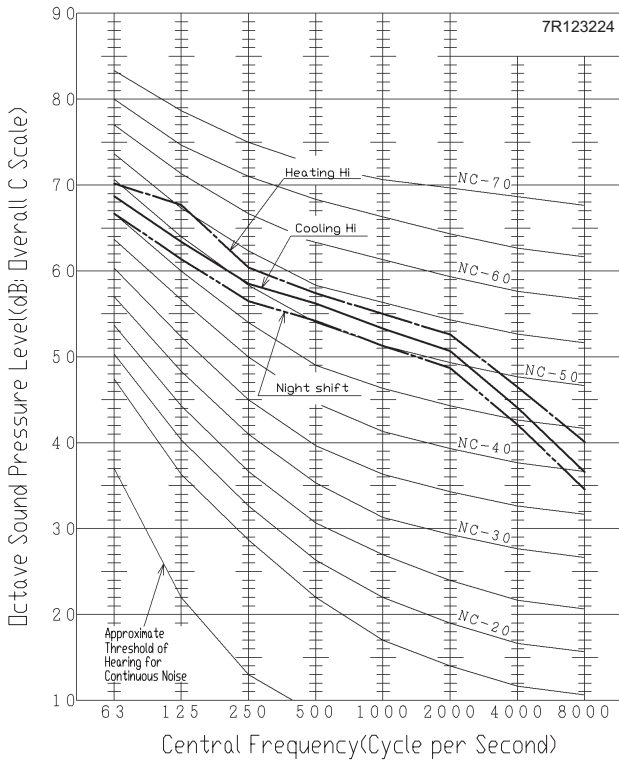

Cooling/Heating/Night mode: 59/61/57 dB(A)

5.2.2 IVX Standard series

RAS-3HVNC

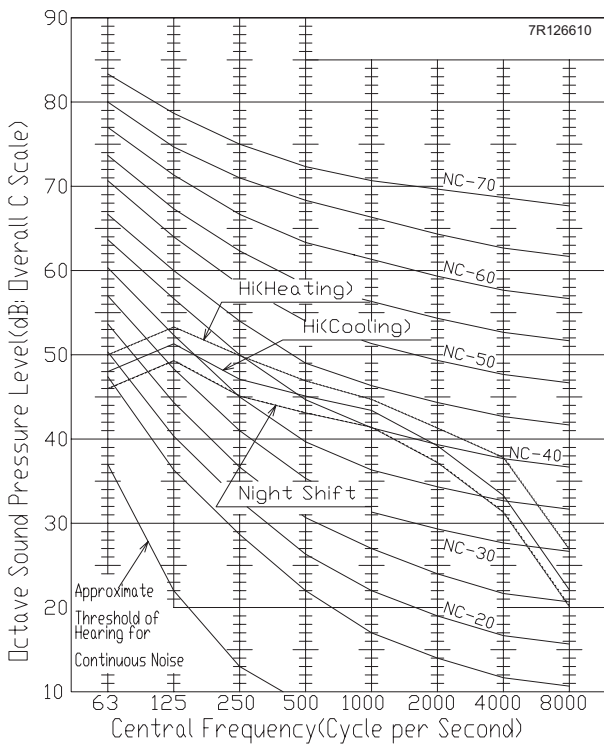

Cooling/Heating/Night mode: 48/50/46 dB(A)

RAS-4H(V)NCE

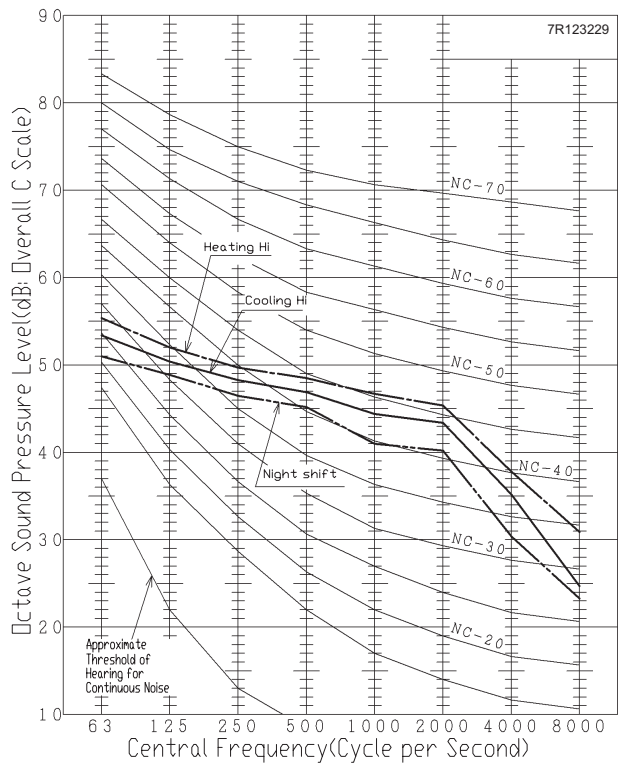

Cooling/Heating/Night mode: 50/52/48 dB(A)

RAS-5H(V)NCE

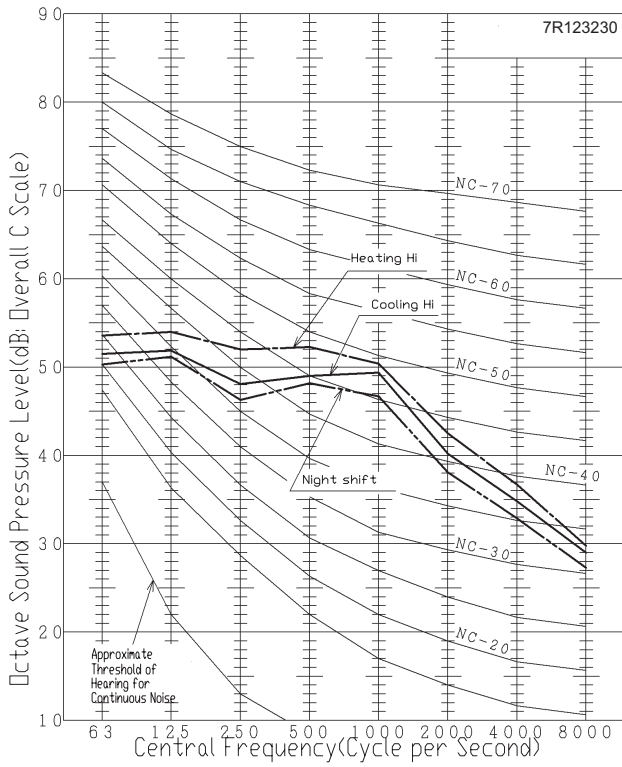

Cooling/Heating/Night mode: 52/54/50 dB(A)

RAS-6H(V)NCE

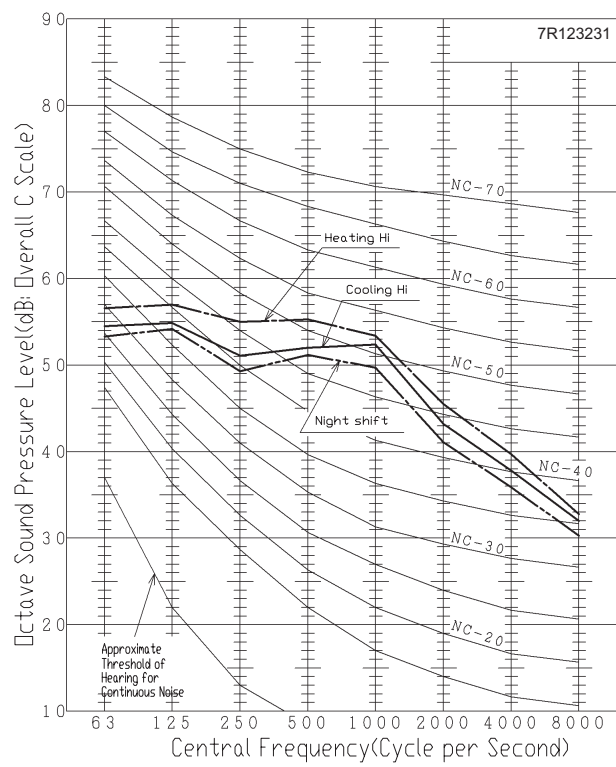

Cooling/Heating/Night mode: 55/57/53 dB(A)

RAS-8HNCE (Preliminary data)

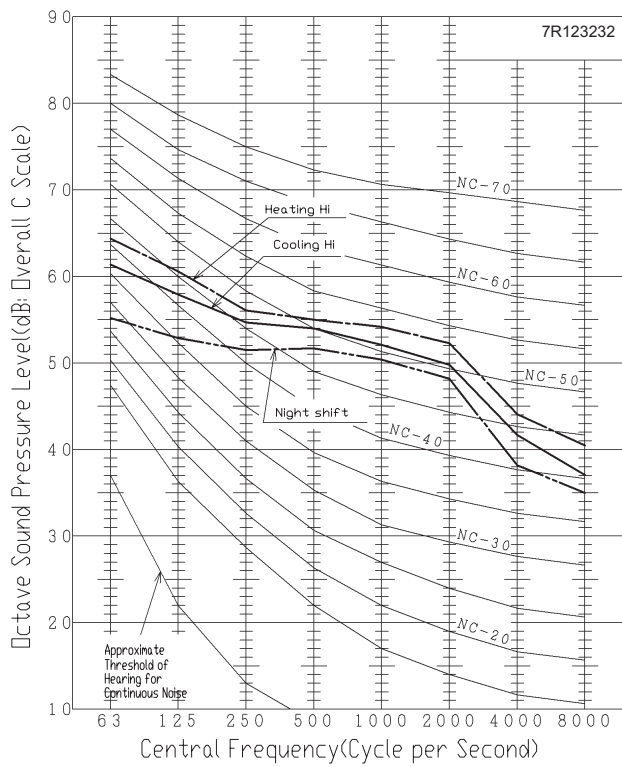

Cooling/Heating/Night mode: 57/59/55 dB(A)

RAS-10HNCE (Preliminary data)

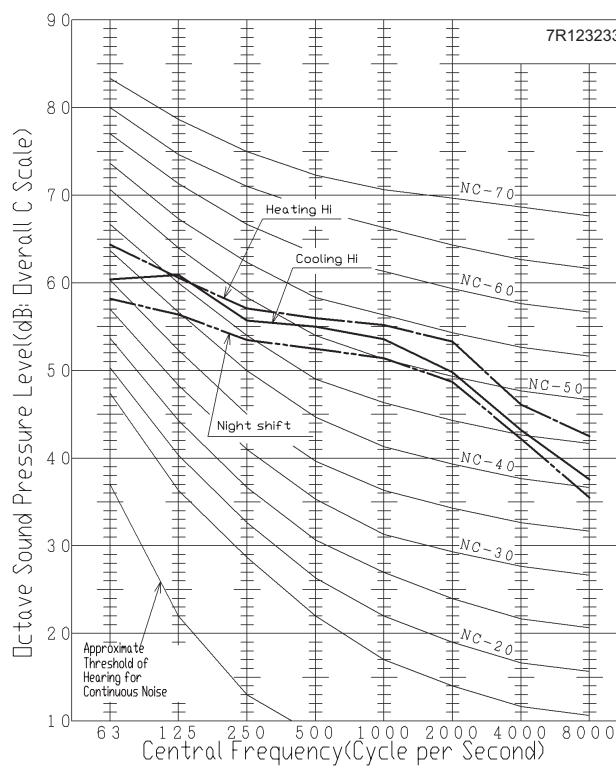

Cooling/Heating/Night mode: 58/60/56 dB(A)

RAS-12HNC (Preliminary data)

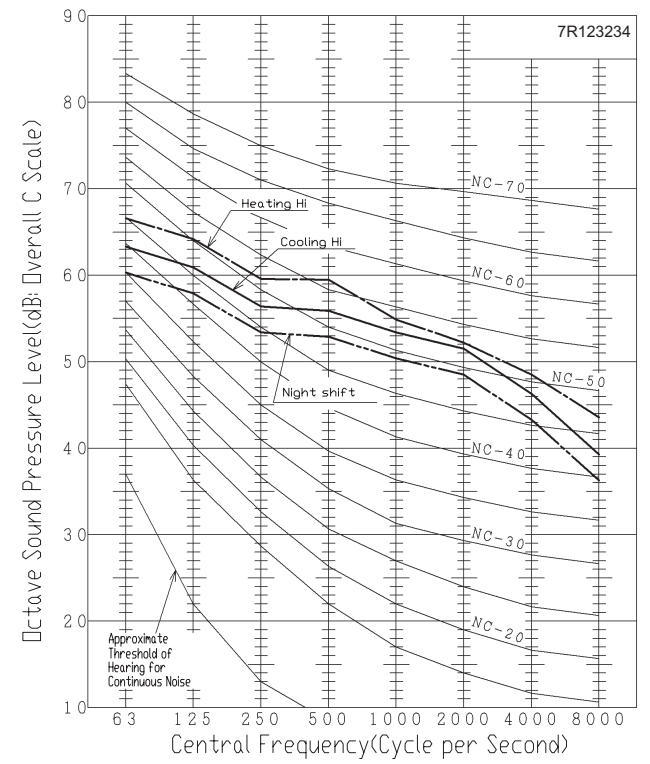

Cooling/Heating/Night mode: 59/61/56 dB(A)

5

6 . Working range

Contents

6. Working range	85
6.1 Working range.....	86
6.1.1 Power supply.....	86
6.1.2 Temperature range.....	87

6.1 Working range

6.1.1 Power supply

Nominal power supply:

- Single phase: 1~ 230V 50Hz
- Three phase: 3N~ 400V 50Hz

Operating voltage

Between 90 and 110% of the nominal voltage.

Voltage imbalance for nominal power supply 3N~ 400V 50Hz

Up to 3% of each phase, measured at the main terminal of the outdoor unit.

Starting voltage

Always higher than 85% of the nominal voltage.

6.1.2 Temperature range

The temperature range is indicated in the following table:

		Cooling mode	Heating mode
Indoor side air inlet temperature	Minimum	21 °C DB / 15 °C WB	15 °C DB
	Maximum	32 °C DB / 23 °C WB	27 °C DB
Outdoor side air inlet temperature	Minimum	-5 °C DB	-20 °C WB
	Maximum	46 °C DB	15 °C WB



NOTE

- DB: Dry Bulb; WB: Wet Bulb.

Cooling mode

- A. Outdoor side air inlet temperature.
- B. Indoor side air inlet temperature.
- C. Working range.

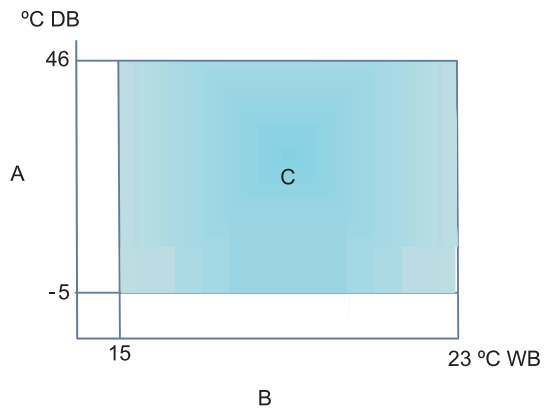

Heating mode

- A. Outdoor side air inlet temperature.
- B. Indoor side air inlet temperature.
- C. Working range.

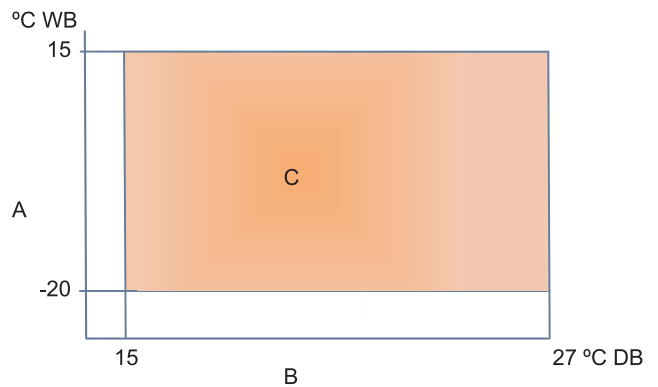

7 . General dimensions

Contents

7. General dimensions.....	89
7.1 Dimensions.....	90
7.1.1 IVX Premium series.....	90
7.1.2 IVX Standard series	94
7.2 Service space.....	98
7.2.1 Basic sizes	98
7.2.2 RAS-(2/2.5)HVNP / RAS-3HVNC.....	98
7.2.3 RAS-(3-12)H(V)N(P/C)(E).....	99

7

7.1 Dimensions

7.1.1 IVX Premium series

◆ RAS-(2/2.5)HVNP

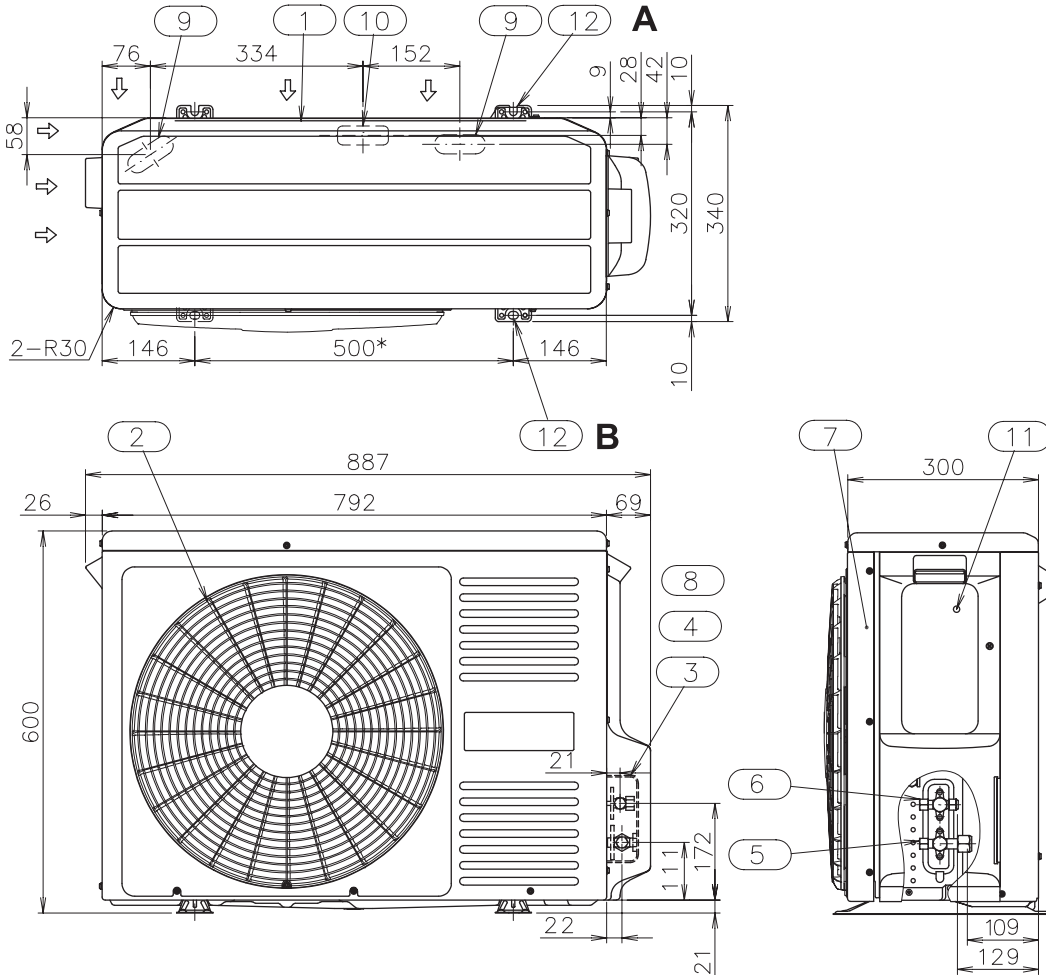

Units in mm.

No.	Description	Remarks
1	Air inlet	—
2	Air outlet	—
3	Holes for power supply wiring	—
4	Holes for control line wiring	—
5	Gas piping connection	—
6	Liquid piping connection	—
7	Service panel	—
8	Refrigerant piping hole	—
9	Drain hole	—
10	Drain hole	—
11	Earth terminal wiring	(M5)
12	Holes for fixing machine to wall	A: 2-U cut holes / B: 2 - holes



◆ **RAS-3HVNPE**

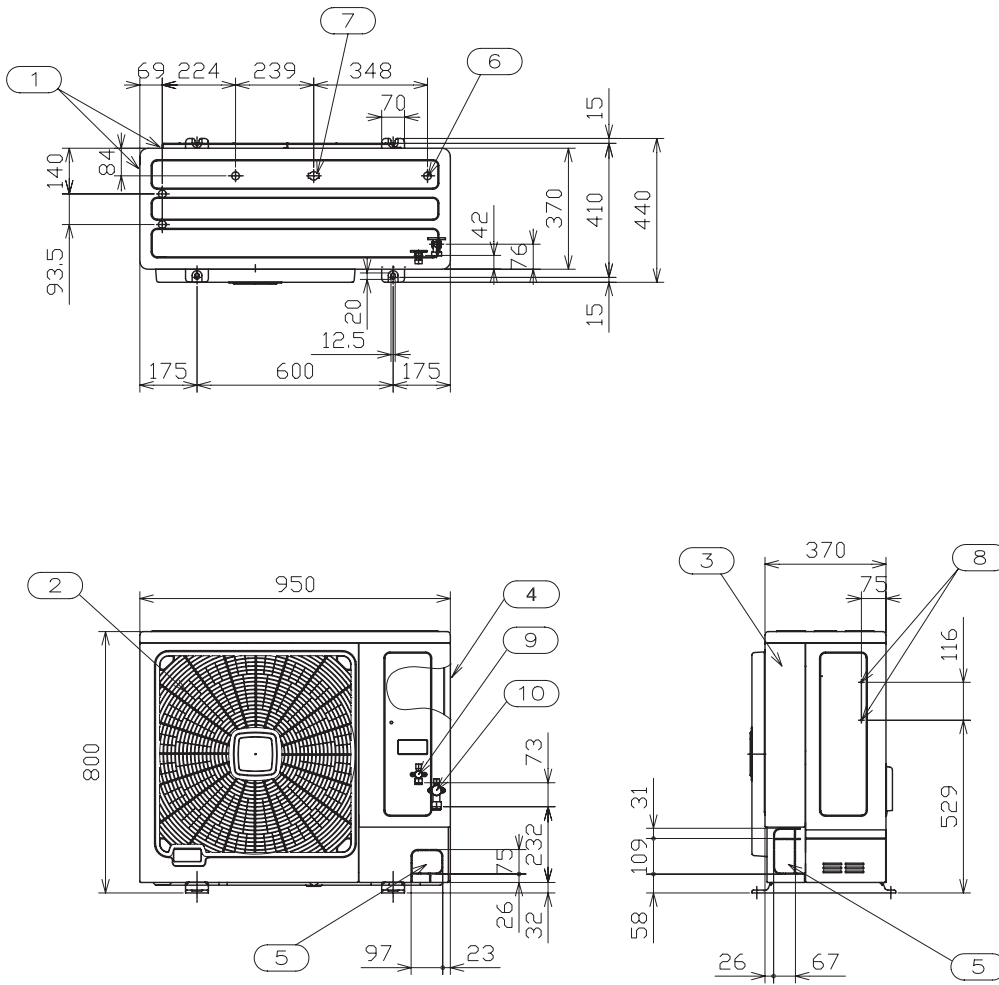

7

Units in mm.

No.	Description	Remarks
1	Air inlet	—
2	Air outlet	—
3	Service cover	—
4	Electrical switch box	—
5	Holes for refrigerant piping and electrical wiring piping	—
6	Drain holes	4-Ø24
7	Drain holes	1-Ø26
8	Holes for fixing machine to wall	4-(M5)
9	Refrigerant liquid pipe	—
10	Refrigerant gas pipe	—



◆ **RAS-(4-10)H(V)NPE**

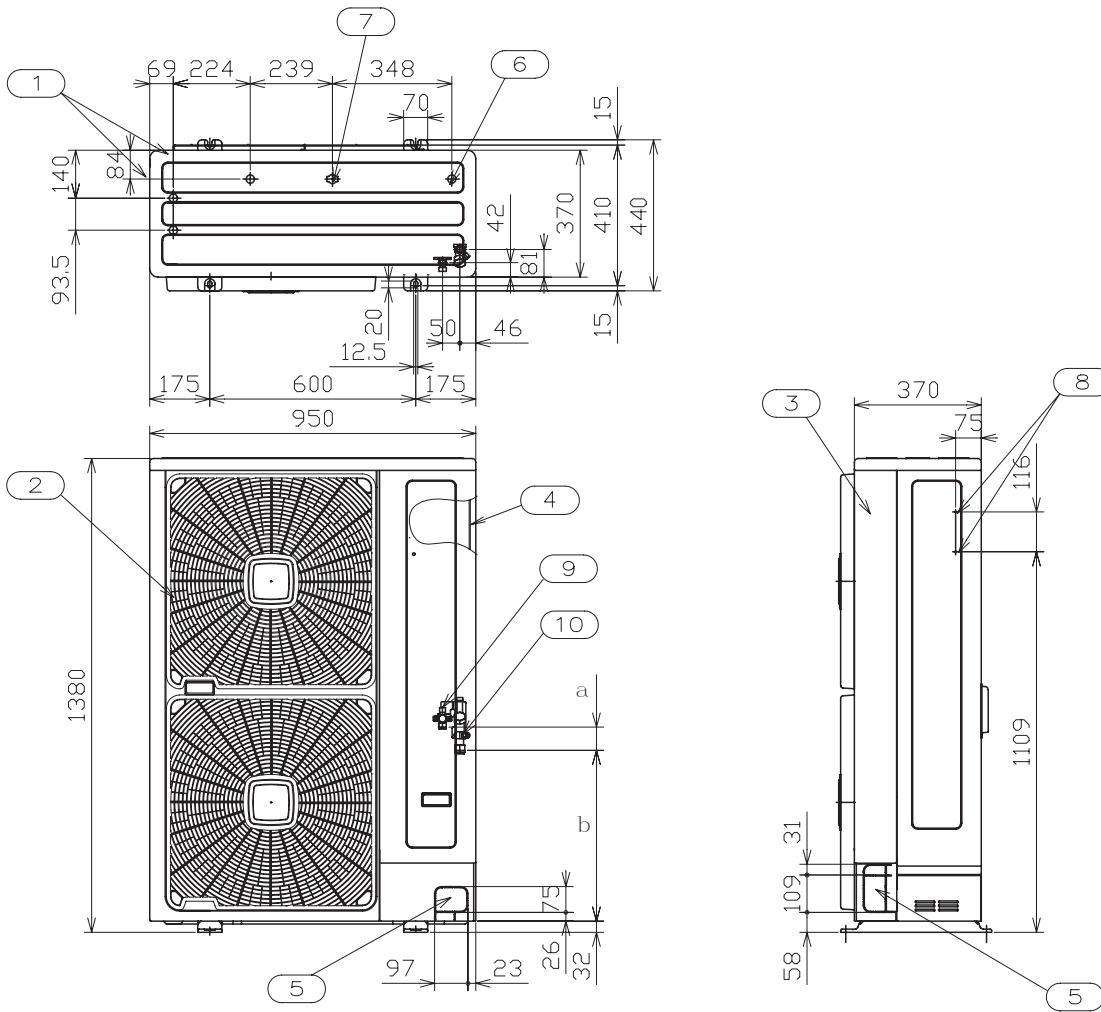

Units in mm.

No.	Description	Remarks
1	Air inlet	—
2	Air outlet	—
3	Service cover	—
4	Electrical switch box	—
5	Holes for refrigerant piping and electrical wiring piping	—
6	Drain holes	3-Ø24
7	Drain holes	2-Ø26
8	Holes for fixing machine to wall	4-(M5)
9	Refrigerant liquid pipe	—
10	Refrigerant gas pipe	—



	4-6 HP	8 HP	10 HP
a	90	81	99
b	459	465	465

◆ **RAS-12HNP**

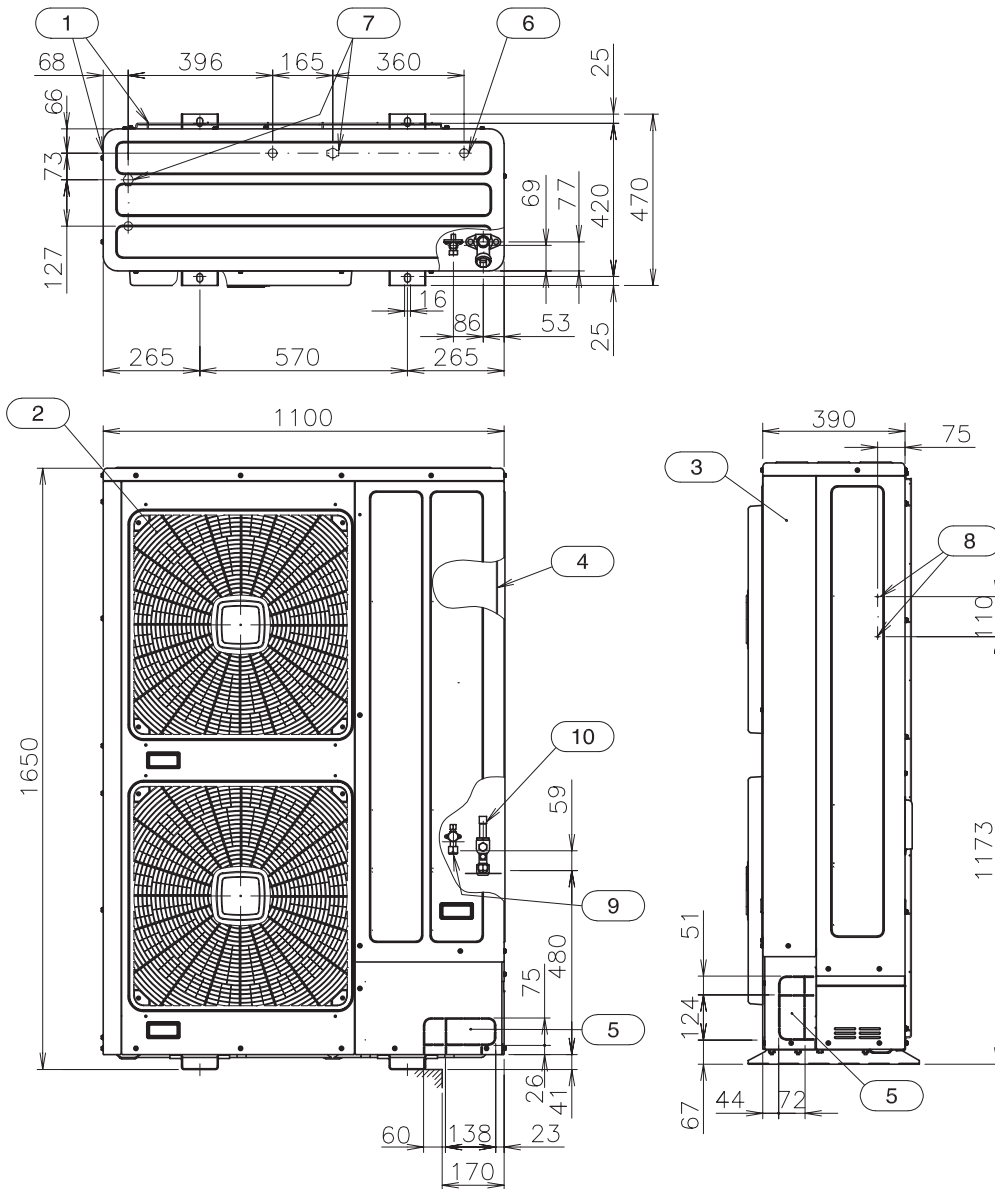

7

Units in mm.

No.	Description	Remarks
1	Air inlet	—
2	Air outlet	—
3	Service cover	—
4	Electrical switch box	—
5	Holes for refrigerant piping and electrical wiring piping	—
6	Drain holes	3-Ø24
7	Drain holes	2-Ø26
8	Holes for fixing machine to wall	4-(M5)
9	Refrigerant liquid pipe	—
10	Refrigerant gas pipe	—



7.1.2 IVX Standard series

◆ **RAS-3HVNC**

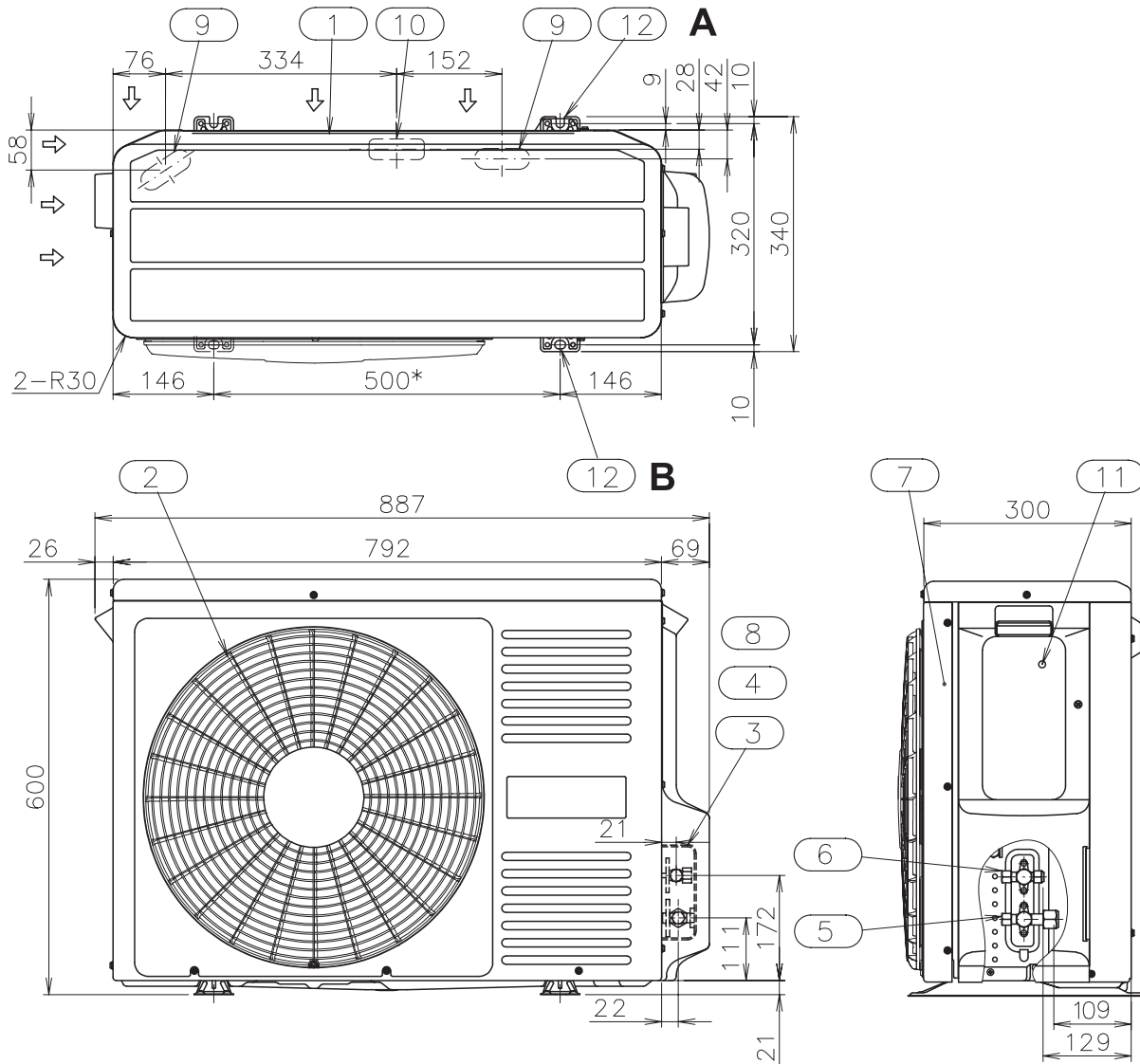

Units in mm.

No.	Description	Remarks
1	Air inlet	—
2	Air outlet	—
3	Holes for power supply wiring	—
4	Holes for control line wiring	—
5	Gas piping connection	—
6	Liquid piping connection	—
7	Service panel	—
8	Refrigerant piping hole	—
9	Drain hole	—
10	Drain hole	—
11	Earth terminal wiring	(M5)
12	Holes for fixing machine to wall	A: 2-U cut holes / B: 2 - holes

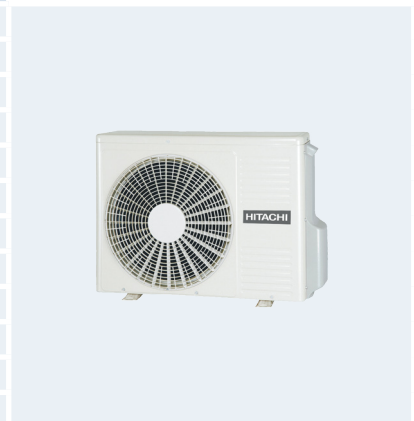

◆ **RAS-(4-6)H(V)NCE**

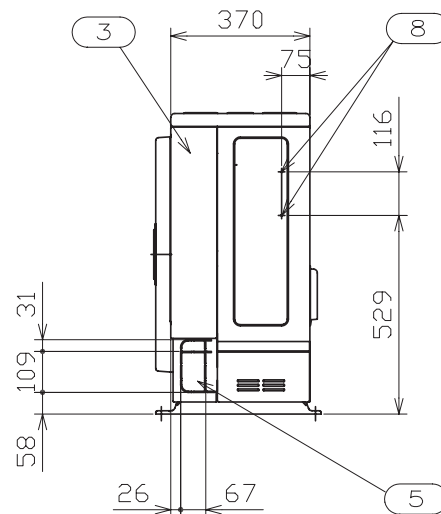
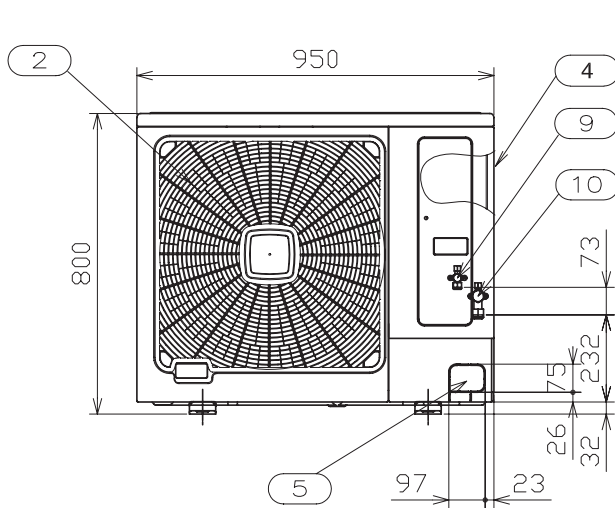
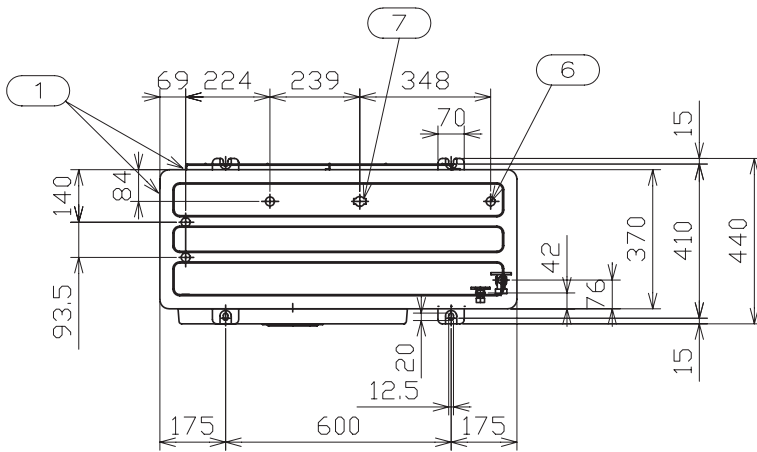

Units in mm.

No.	Description	Remarks
1	Air inlet	—
2	Air outlet	—
3	Service cover	—
4	Electrical switch box	—
5	Holes for refrigerant piping and electrical wiring piping	—
6	Drain holes	4-Ø24
7	Drain holes	1-Ø26
8	Holes for fixing machine to wall	4-(M5)
9	Refrigerant liquid pipe	—
10	Refrigerant gas pipe	—



7

◆ **RAS-(8/10)HNCE**

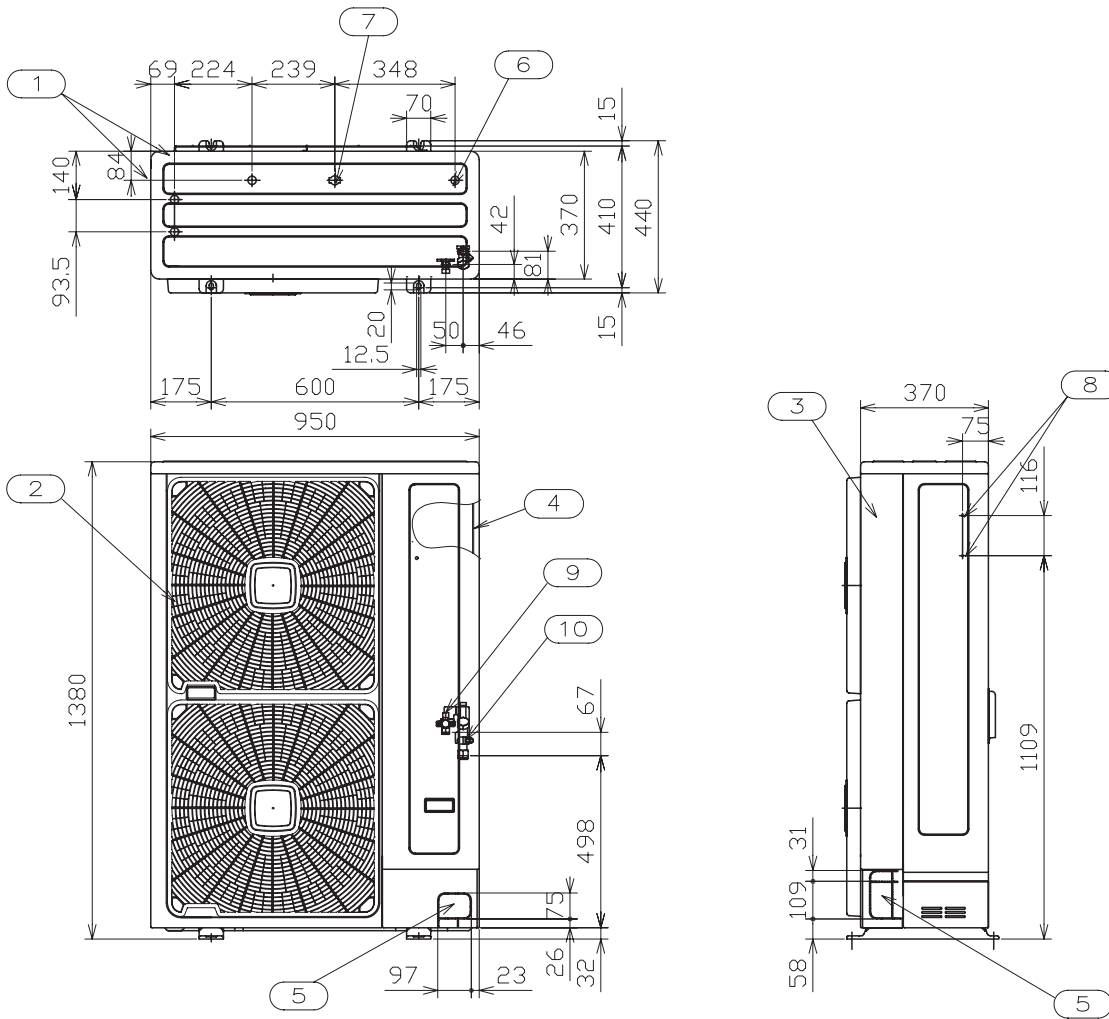

Units in mm.

No.	Description	Remarks
1	Air inlet	—
2	Air outlet	—
3	Service cover	—
4	Electrical switch box	—
5	Holes for refrigerant piping and electrical wiring piping	—
6	Drain holes	3-Ø24
7	Drain holes	2-Ø26
8	Holes for fixing machine to wall	4-(M5)
9	Refrigerant liquid pipe	—
10	Refrigerant gas pipe	—



◆ **RAS-12HNC**

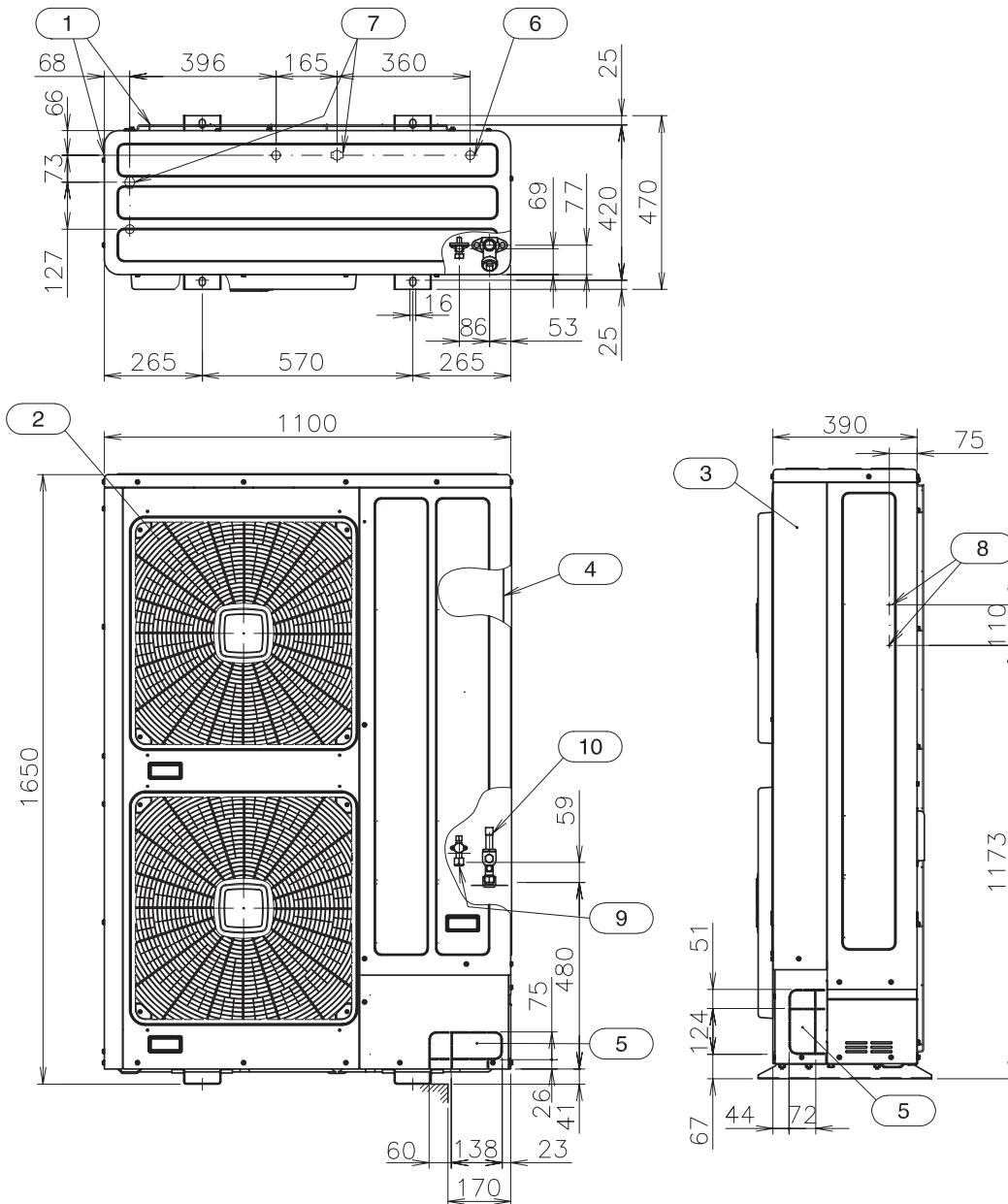

7

Units in mm.

No.	Description	Remarks
1	Air inlet	—
2	Air outlet	—
3	Service cover	—
4	Electrical switch box	—
5	Holes for refrigerant piping and electrical wiring piping	—
6	Drain holes	3-Ø24
7	Drain holes	2-Ø26
8	Holes for fixing machine to wall	4-(M5)
9	Refrigerant liquid pipe	—
10	Refrigerant gas pipe	—



7.2 Service space

7.2.1 Basic sizes

◆ RAS-2HVNP - RAS-2.5HVNP - RAS-3HVNC

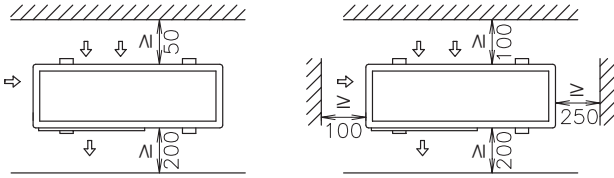

◆ All models (except RAS-2HVNP - RAS-2.5HVNP - RAS-3HVNC)

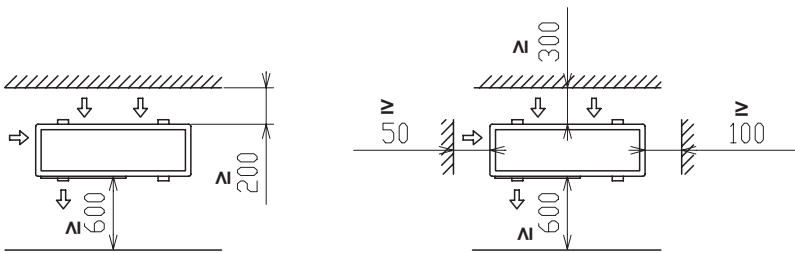

Units in mm.



NOTE

- For the specific information, please refer to the Service Manual.

7.2.2 RAS-(2/2.5)HVNP / RAS-3HVNC

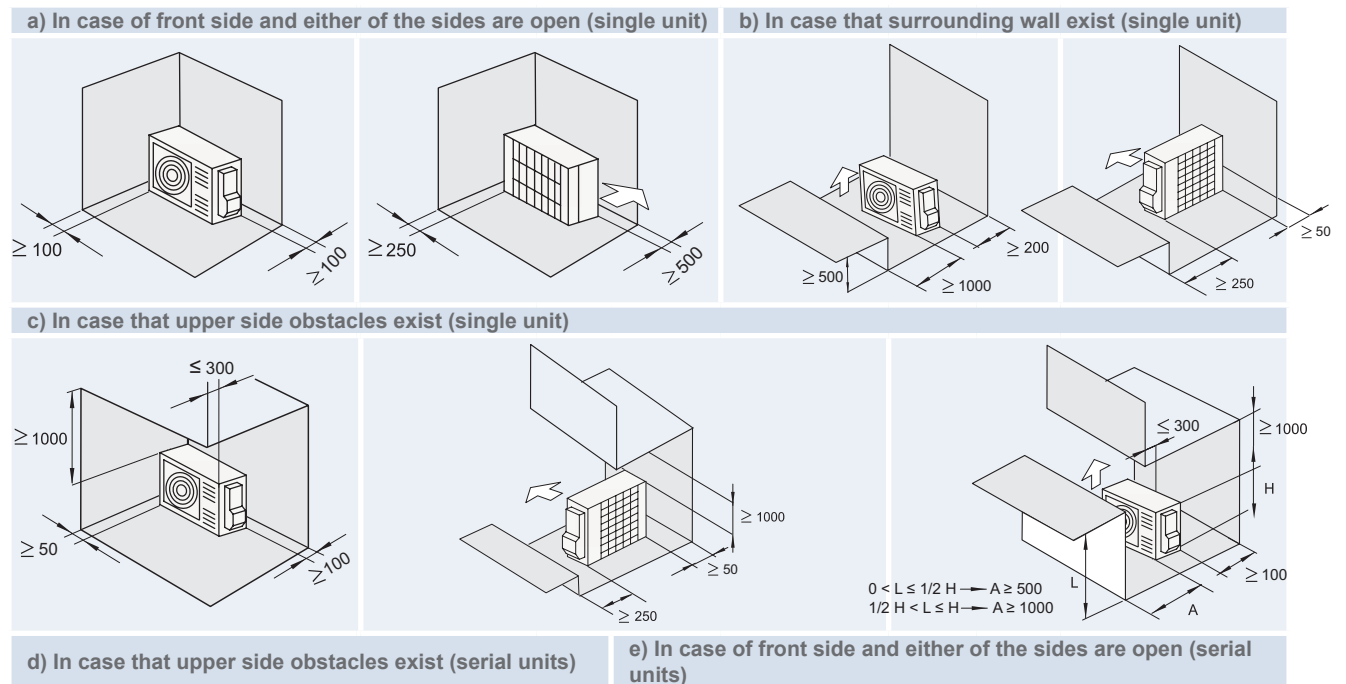

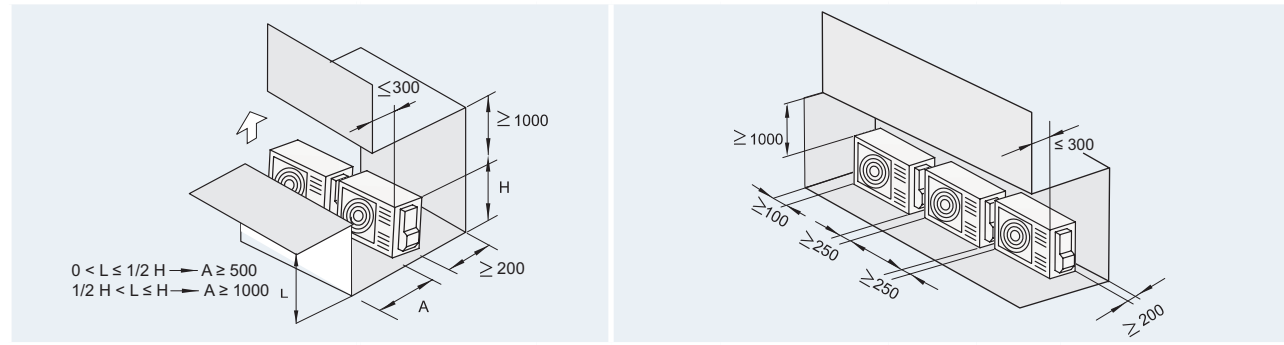

f) In case that surrounding wall exist (serial units)

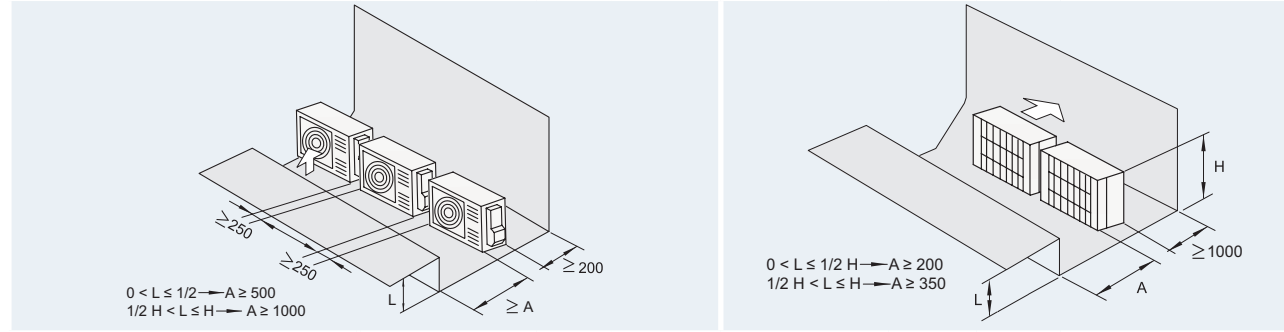

g) Horizontal (multiple units)

h) Vertical (multiple units)

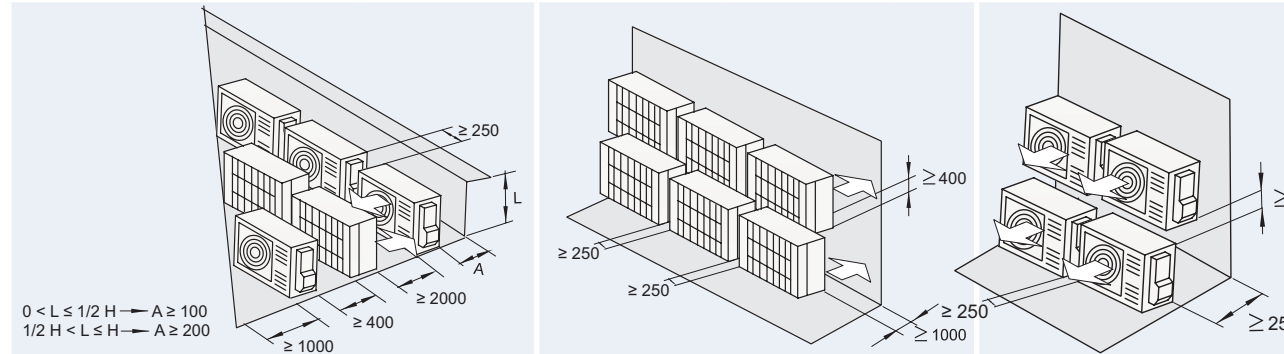

- Do not stack more than two units in height.
- Close gap (*) to avoid recirculating discharge air flow.

7.2.3 RAS-(3-12)H(V)N(P/C)(E)

(Unit: mm)

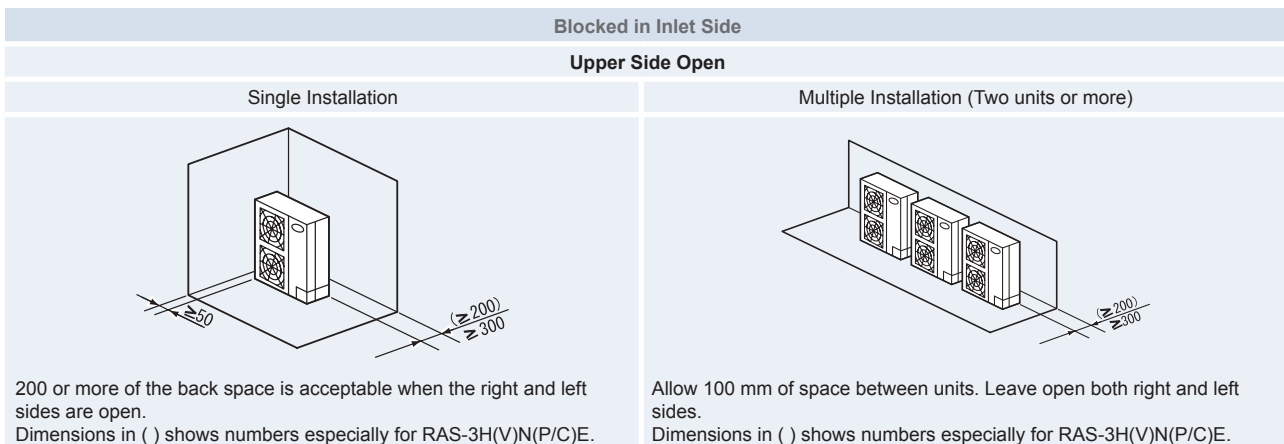

7

Blocked in Inlet Side

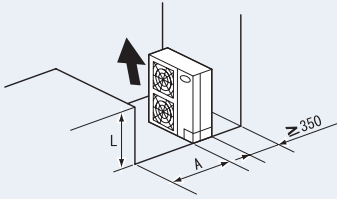

Be sure to use the fan direction guide. Leave open both right and left sides.

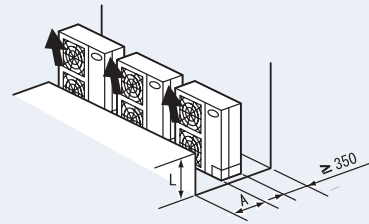

Be sure to use the fan direction guide. Allow 100 mm of space between units. Leave open both right and left sides.

Upper Side Blocked

Single Installation

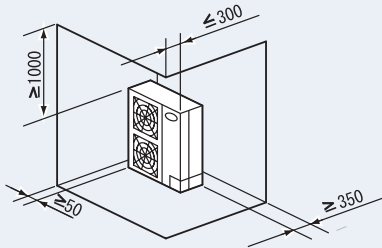

100 mm or more of the side space is acceptable on the service cover side.

Multiple Installation (Two units or more)

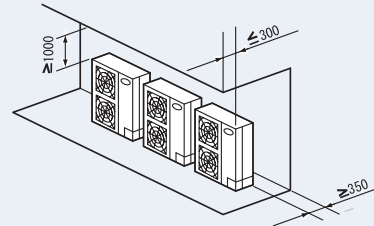

Allow 100 mm of space between units. Leave open both right and left sides..

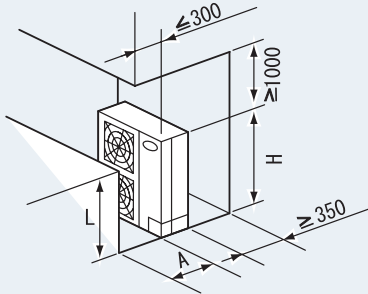

Leave open both right and left sides.

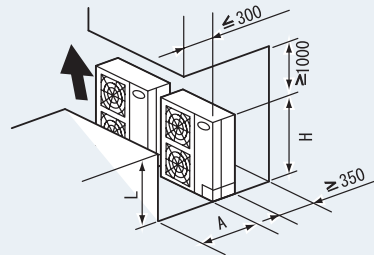

Be sure to use the fan direction guide. Allow 100 mm of space between units. Leave open both right and left sides. No more than 2 units for multiple installation.

The length A is as shown in the following table:

L	A
$0 < L \leq 1/2H$	600 or greater
$1/2H < L \leq H$	1400 or greater

When $L > H$ use a base for outdoor unit to make $L \leq H$. Close the base not to allow the outlet air bypassed.

Outlet Side Blocked

Upper Side Open

Single Installation

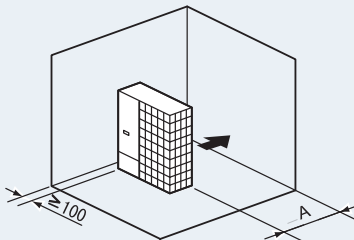

Multiple Installation (Two units or more)

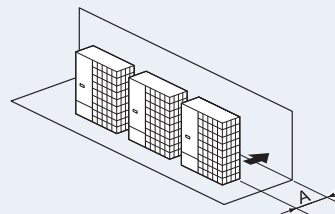

Allow 100 mm of space between units. Both right and left sides shall be open.

Outlet Side Blocked

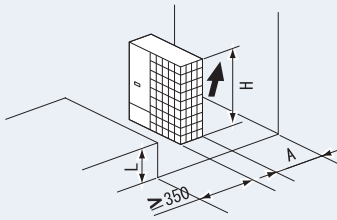

Be sure to use the fan direction guide. Leave open both right and left sides.

The length A is as shown in the following table:

L	A
$0 < L \leq 1/2H$	600 or greater
$1/2H < L \leq H$	1400 or greater

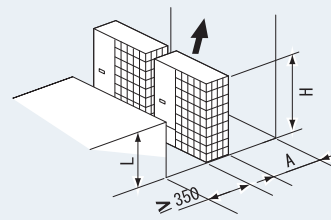

Be sure to use the fan direction guide. Allow 100 mm of space between units. Leave open both right and left sides. No more than 2 units for multiple installation.

When $L > H$ use a base for outdoor unit to make $L \leq H$. Close the base not to allow the outlet air bypassed.





8 . Refrigerant cycle

Contents

8. Refrigerant cycle	103
8.1 General notes.....	104
8.2 IVX Premium series.....	105
8.3 IVX Standard series	108

8.1 General notes

Mark	Part name
A	Gas line refrigerant piping connection
B	Liquid line refrigerant piping connection
C	Outdoor unit
D	Ambient thermistor
E	Discharge gas thermistor
F	Pipe thermistor

				R410A	4.15 MPa
Refrigerant flow for cooling	Refrigerant flow for heating	Connection by flare nut	Connection by welding	Gas refrigerant	Leakage test pressure

8.2 IVX Premium series

◆ RAS-(2/2.5)HVNP

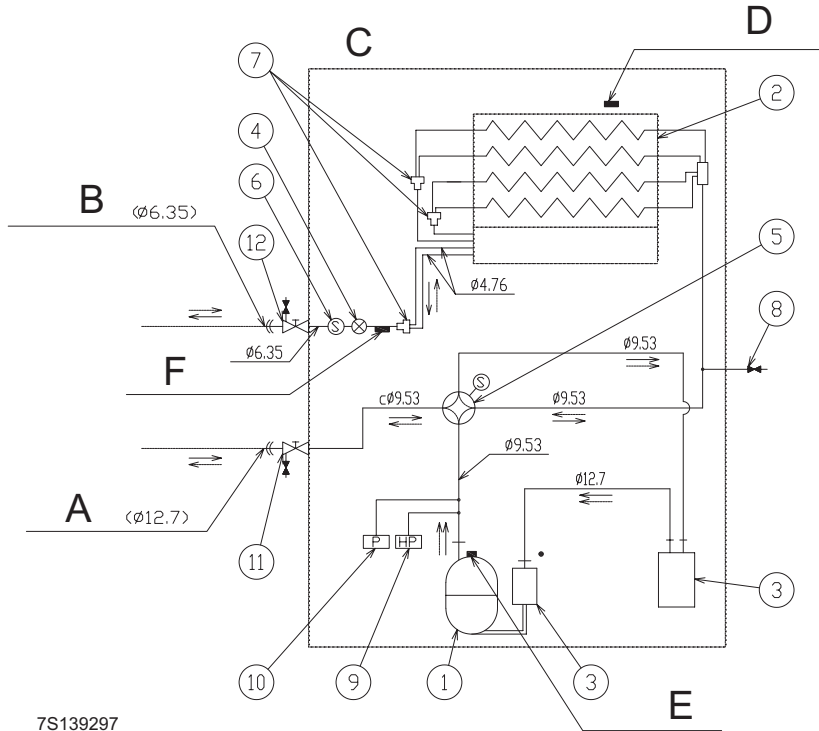

7S139297

Mark	Part name
1	Compressor
2	Heat exchanger
3	Accumulator
4	Micro-computer control expansion valve
5	Reversing valve
6	Strainer
7	Distributor
8	Check joint
9	High pressure switch for protection
10	Pressure switch for control
11	Stop valve for gas line
12	Stop valve for liquid line

8

◆ RAS-3HVNPE

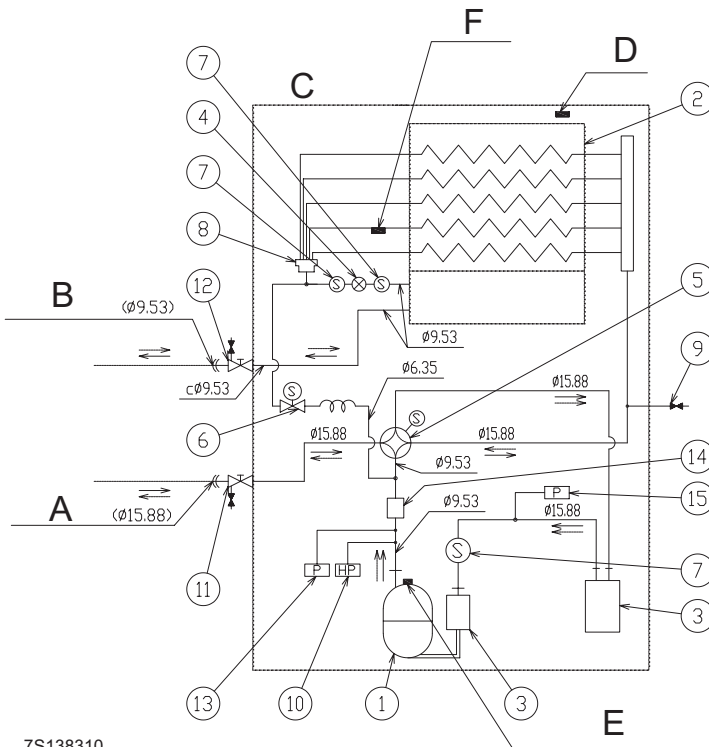

7S138310

Mark	Part name
1	Compressor
2	Heat exchanger
3	Accumulator
4	Micro-computer control expansion valve
5	Reversing valve
6	Solenoid valve for gas bypass
7	Strainer
8	Distributor
9	Check joint
10	High pressure switch for protection
11	Stop valve for gas line
12	Stop valve for liquid line
13	Sensor for refrigerant pressure
14	Silencer
15	Pressure switch for control

◆ **RAS-(4-6)H(V)NPE**

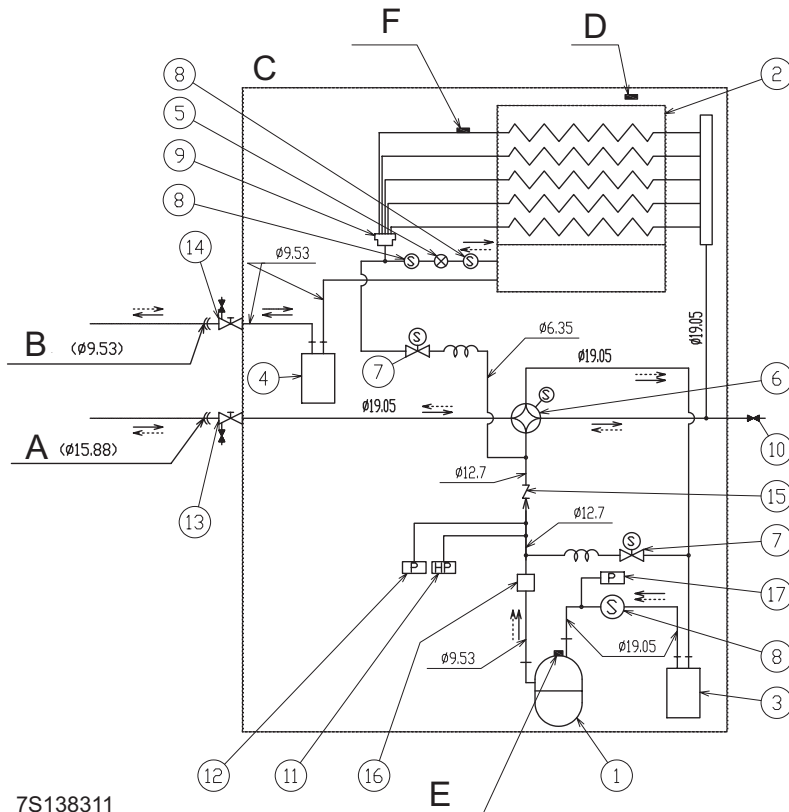

7S138311

Mark	Part name
1	Compressor
2	Heat exchanger
3	Accumulator
4	Receiver
5	Micro-computer control expansion valve
6	Reversing valve
7	Solenoid valve for gas bypass
8	Strainer
9	Distributor
10	Check joint
11	High pressure switch for protection
12	Sensor for refrigerant pressure
13	Stop valve for gas line
14	Stop valve for liquid line
15	Check valve
16	Silencer
17	Pressure switch for control

◆ **RAS-(8/10)HNPE**

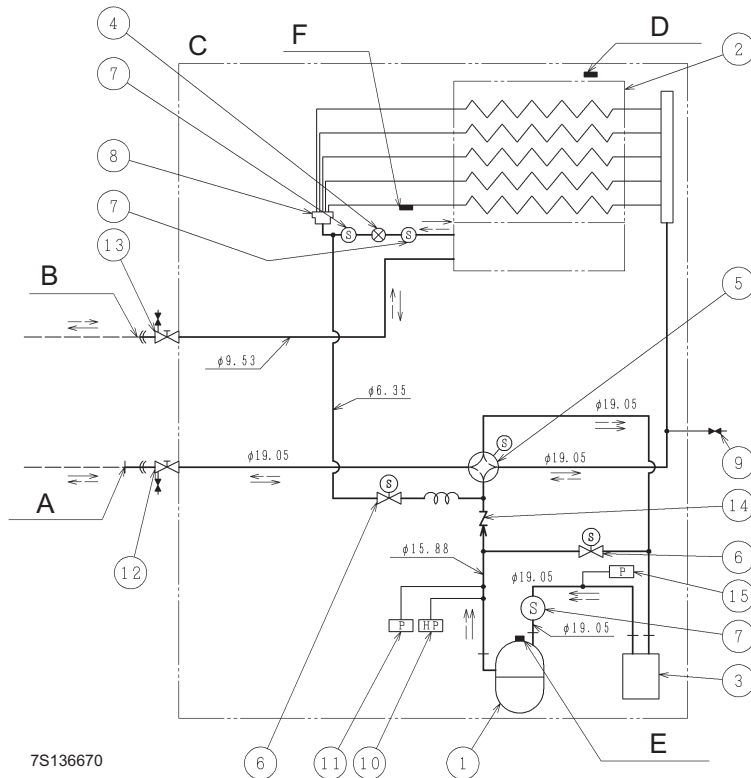

7S136670

Mark	Part name
1	Compressor
2	Heat exchanger
3	Accumulator
4	Micro-computer control expansion valve
5	Reversing valve
6	Solenoid valve for gas bypass
7	Strainer
8	Distributor
9	Check joint
10	High pressure switch for protection
11	Sensor for refrigerant pressure
12	Stop valve for gas line
13	Stop valve for liquid line
14	Check valve
15	Pressure switch for control

◆ **RAS-12HNP**

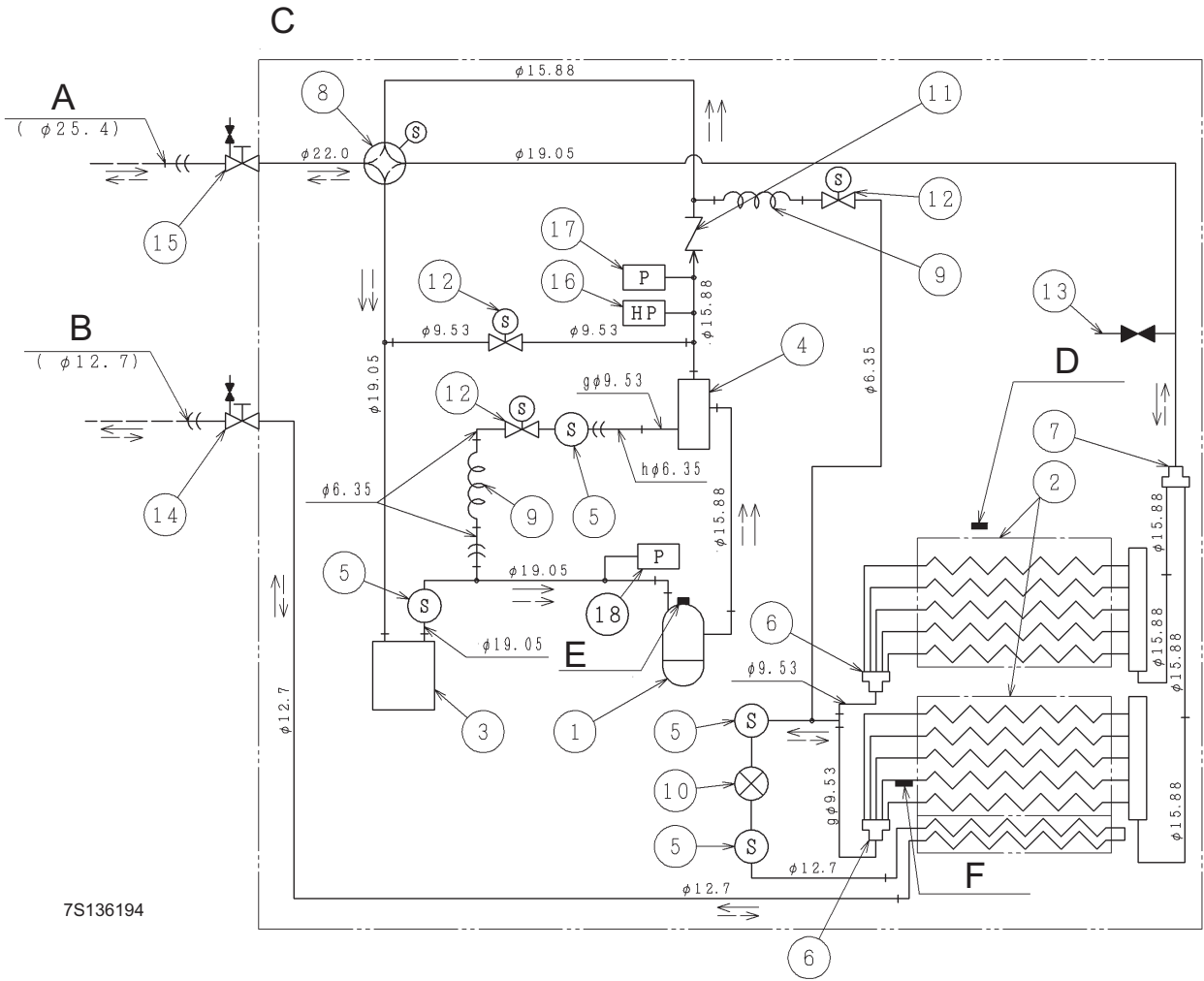

7S136194

Mark	Part name	Mark	Part name
1	Compressor	10	Expansion valve
2	Heat exchanger	11	Check valve
3	Accumulator	12	Solenoid valve for gas bypass
4	Oil separator	13	Check joint
5	Strainer	14	Stop valve for liquid line
6	Distributor	15	Stop valve for gas line
7	Distributor	16	High pressure switch for protection
8	Reversing valve	17	Sensor for refrigerant pressure
9	Capillary tube	18	Pressure switch for control

8

8.3 IVX Standard series

◆ RAS-3HVNC

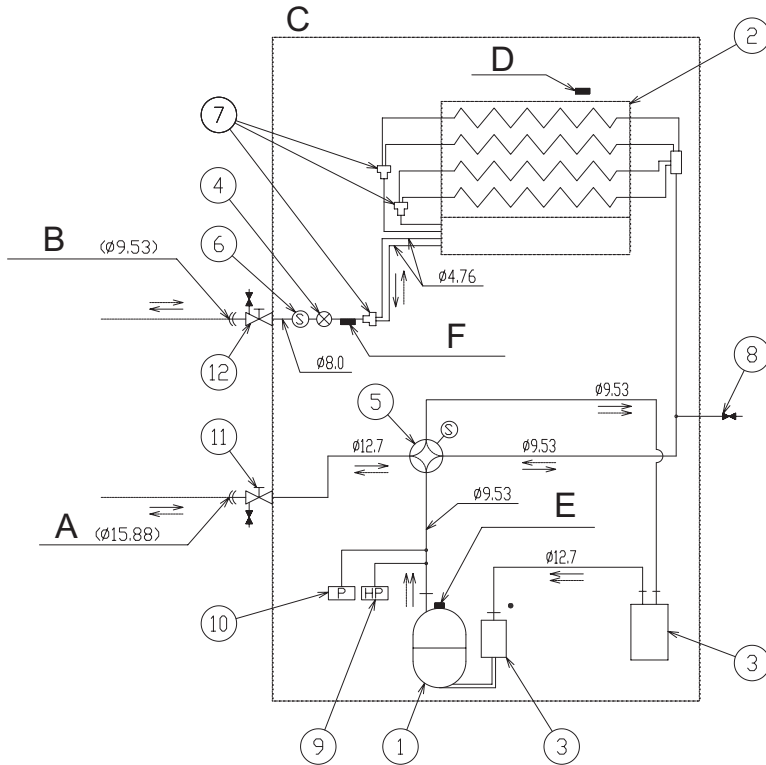

Mark	Part name
1	Compressor
2	Heat exchanger
3	Accumulator
4	Micro-computer control expansion valve
5	Reversing valve
6	Strainer
7	Distributor
8	Check joint
9	High pressure switch for protection
10	Pressure switch for control
11	Stop valve for gas line
12	Stop valve for liquid line

7S139296

◆ RAS-4H(V)NCE

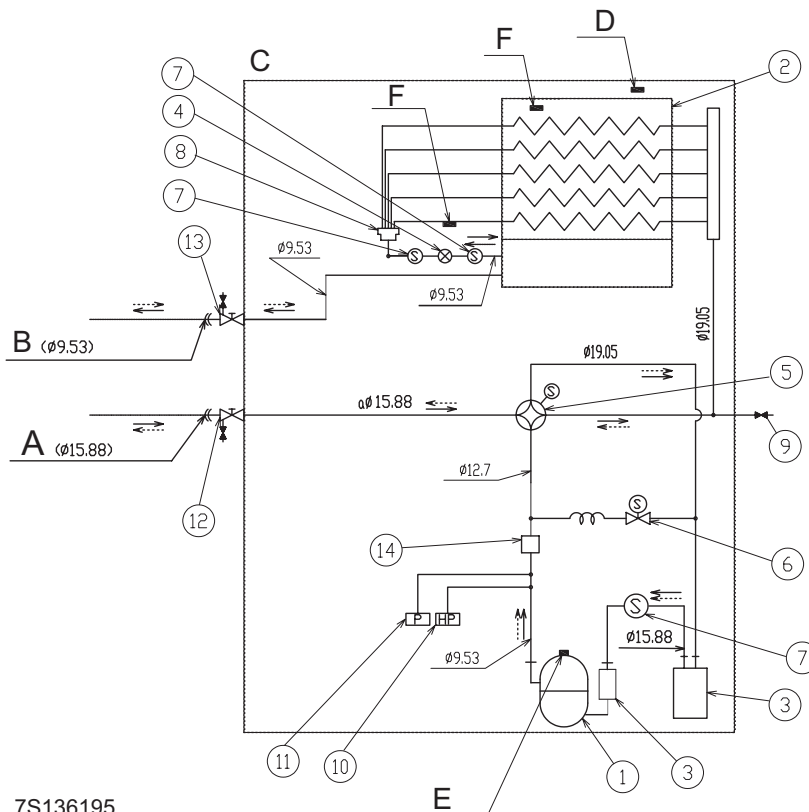

Mark	Part name
1	Compressor
2	Heat exchanger
3	Accumulator
4	Micro-computer control expansion valve
5	Reversing valve
6	Solenoid valve for gas bypass
7	Strainer
8	Distributor
9	Check joint
10	High pressure switch for protection
11	Pressure switch for control
12	Stop valve for gas line
13	Stop valve for liquid line
14	Silencer

7S136195

◆ **RAS-(5/6)H(V)NCE**

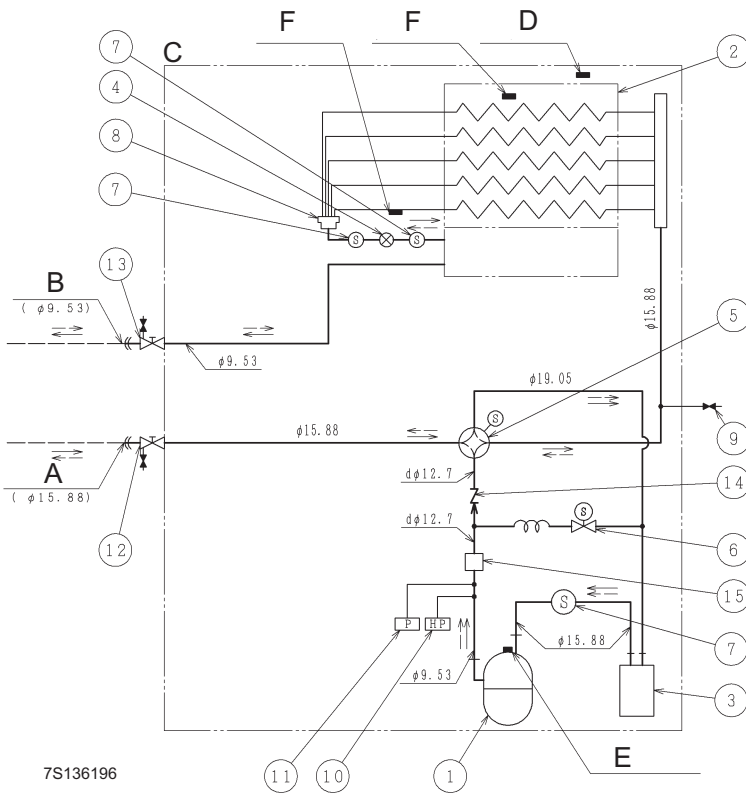

7S136196

Mark	Part name
1	Compressor
2	Heat exchanger
3	Accumulator
4	Micro-computer control expansion valve
5	Reversing valve
6	Solenoid valve for gas bypass
7	Strainer
8	Distributor
9	Check joint
10	High pressure switch for protection
11	Pressure switch for control
12	Stop valve for gas line
13	Stop valve for liquid line
14	Check valve
15	Silencer

8

◆ **RAS-(8/10)HNCE**

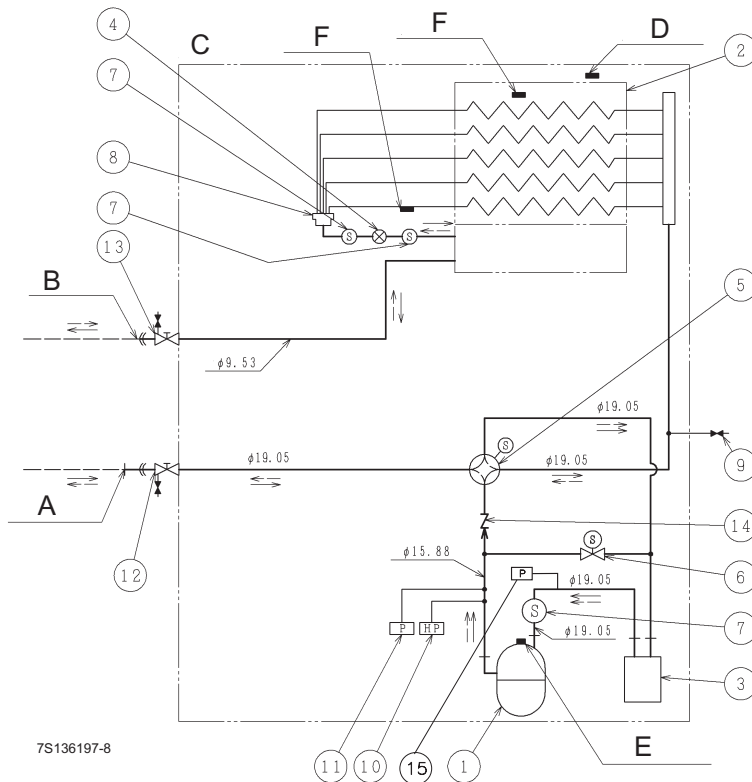

7S136197-8

Mark	Part name
1	Compressor
2	Heat exchanger
3	Accumulator
4	Micro-computer control expansion valve
5	Reversing valve
6	Solenoid valve for gas bypass
7	Strainer
8	Distributor
9	Check joint
10	High pressure switch for protection
11	Pressure switch for control
12	Stop valve for gas line
13	Stop valve for liquid line
14	Check valve
15	Pressure switch for control

◆ **RAS-12HNC**

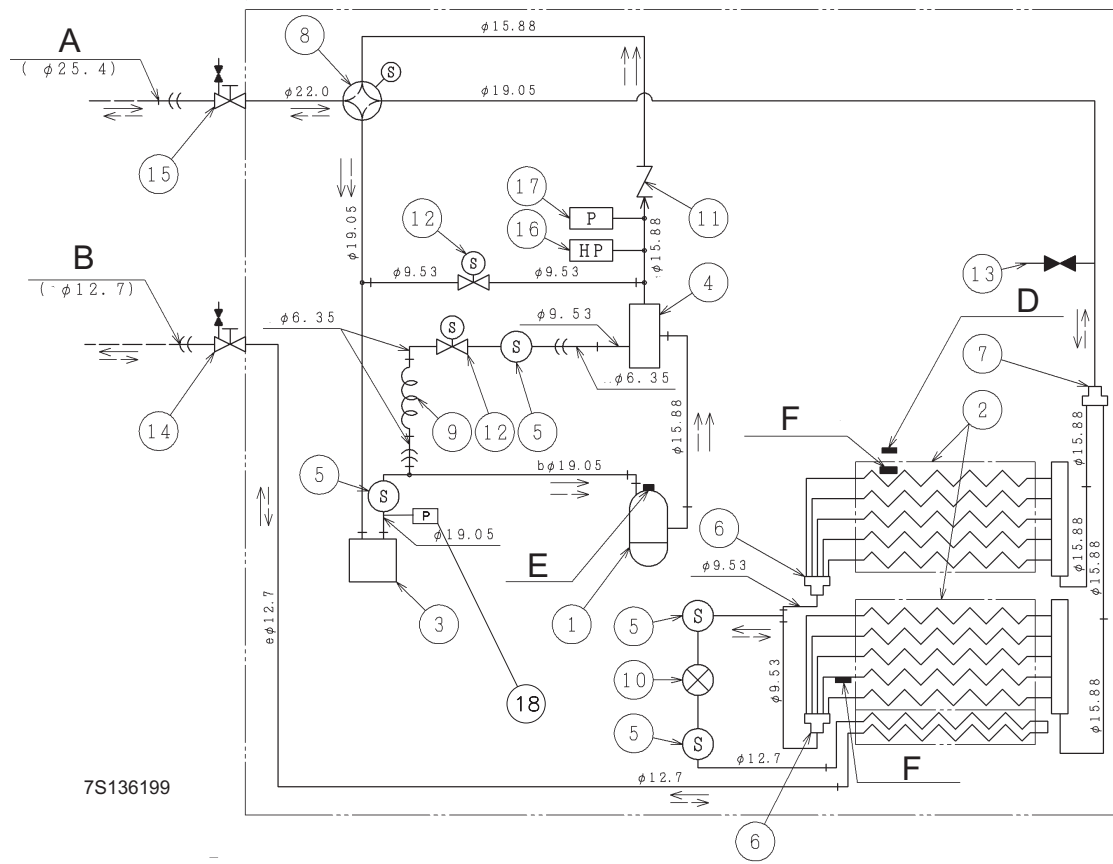

Mark	Part name	Mark	Part name
1	Compressor	10	Expansion valve
2	Heat exchanger	11	Check valve
3	Accumulator	12	Solenoid valve for gas bypass
4	Oil separator	13	Check joint
5	Strainer	14	Stop valve for liquid line
6	Distributor	15	Stop valve for gas line
7	Distributor	16	High pressure switch for protection
8	Reversing valve	17	Sensor for refrigerant pressure
9	Capillary tube	18	Pressure switch for control

9 . Piping work and refrigerant charge

Contents

9. Piping work and refrigerant charge	111
9.1 Refrigerant pipe selection.....	112
9.1.1 Pipe size selection.....	112
9.1.2 Multikit or distributor selection	112
9.2.1 Refrigerant piping length	112
9.2.2 Piping system for header branch.....	113
9.2.3 Piping system for line branch	114
9.2.4 Combinations of piping size and piping length.....	115
9.2.5 Refrigerant piping size and multikit/distributor.....	116
9.3 Copper pipes, sizes and connection	119
9.3.1 Copper pipes and sizes.....	119
9.3.2 Pipe connection.....	120
9.3.3 Insulation	120
9.4 Refrigerant charge amount.....	121
9.4.1 Refrigerant charge before shipment (W0 (kg)).....	121
9.4.2 Calculation method for the additional refrigerant charge.....	121
9.5 Caution in case of refrigerant leakage.....	124
9.5.1 Maximum permitted concentration of hydrofluorocarbon (HFC)	124
9.5.2 Calculation of refrigerant concentration.....	124
9.5.3 Countermeasure for refrigerant leakage	124
9.6 Compatibility with the piping of current where R22 or R407C is used.	125
9.6.1 Installation procedure for existing pipes	125
9.6.2 When existing Air-Conditioner is a product of another manufacturer	125
9.6.3 Permissible range for existing Air-Conditioning Pipes (Pipe length in the case of “without cleaning process”.....	126
9.6.4 Renewal kit selection model.....	127

9.1 Refrigerant pipe selection

9.1.1 Pipe size selection

Select the pipe size in line with the following instructions:

- 1 Between the outdoor unit and the branch pipe (multikit): select the same pipe connection size as for the outdoor unit.
- 2 Between the branch pipe (multikit) and the indoor unit: select the same pipe connection size as for the indoor unit.
- 3 Between branch pipes (multikits): select the pipe connection size according the equivalent indoor unit size if adding up the units after the branch pipe



CAUTION

- **Do not use refrigerant pipe sizes other than those indicated in this Technical Catalogue. The diameter of the refrigerant pipes depends directly on the outdoor unit capacity.**
- **If larger diameter gas refrigerant pipes are used, the circuit lubrication oil tends to separate from the gas carrying it. The compressor will be seriously damaged due to a lack of lubrication.**
- **If smaller diameter gas refrigerant pipes are used, the gas or liquid refrigerant will have serious difficulties in circulating. System performance will be affected. The compressor will run under more severe conditions than foreseen and will be damaged in a short space of time.**

9.1.2 Multikit or distributor selection

- **Pipe connection size on outdoor units, indoor units and the multikit or distributor vary according to the system.**
- **The sizes of the indoor and outdoor units could be different. Adjust the flare adapter (accessory) to the indoor pipe connection in these cases.**

9.2 Refrigerant piping range

9.2.1 Refrigerant piping length

The refrigerant piping between the indoor unit and the outdoor unit should be designed using the following chart.

Keep the design point within the area of the chart, which is showing the applicable height difference according to piping length.

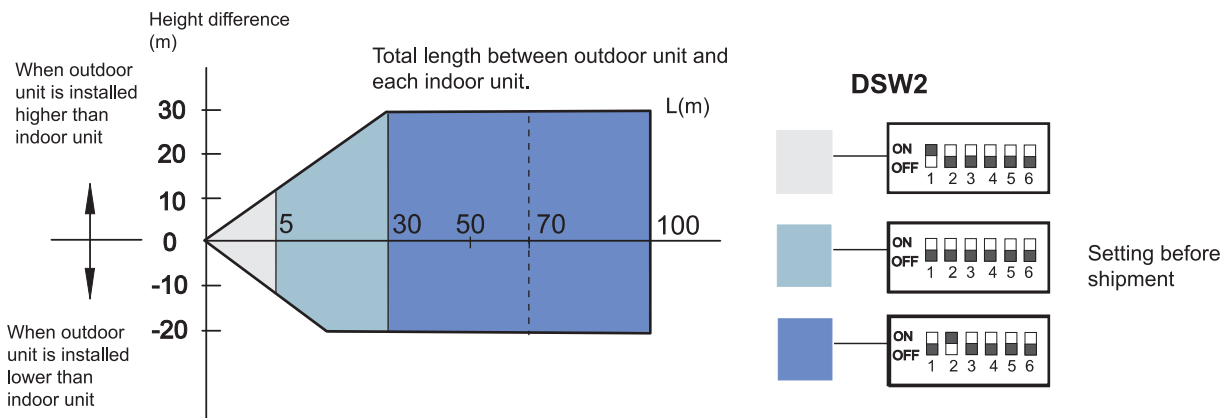

9.2.2 Piping system for header branch

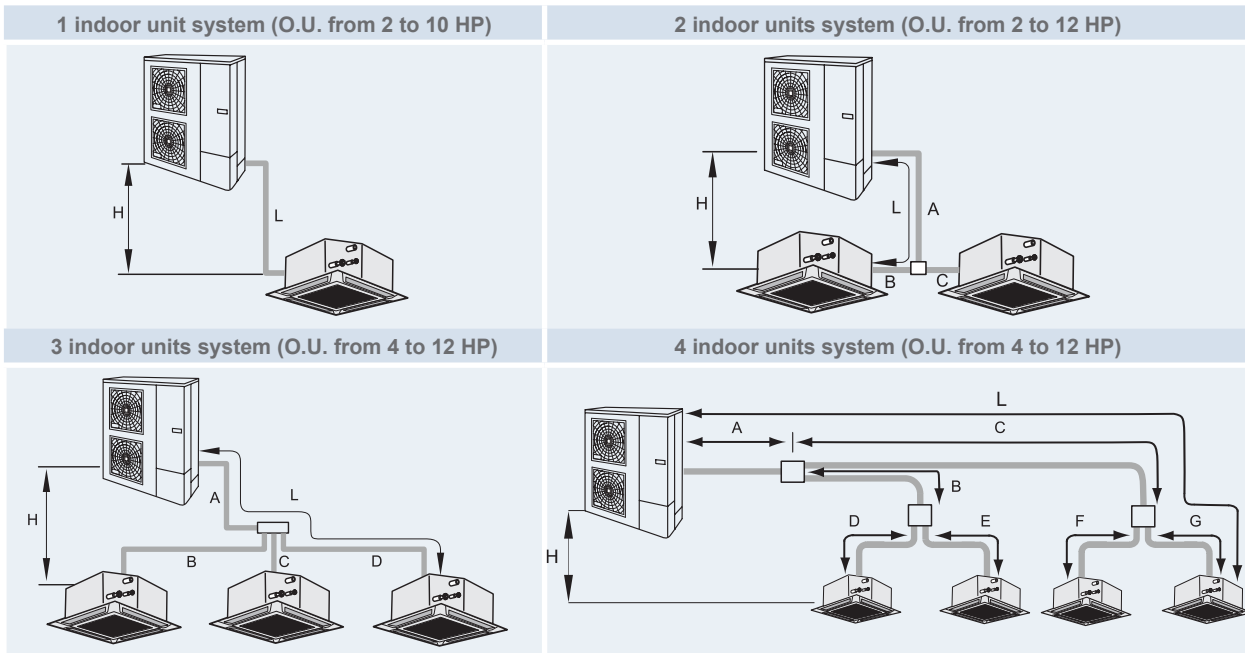

(pictures are as example)

◆ Maximum refrigerant piping length

IVX Premium series

Outdoor Unit		2 HP	2.5 HP	3HP	4HP	5HP	6HP	8HP	10HP	12HP
Maximum piping length between the outdoor unit and the farthest indoor unit	Actual Length (L)	50			75			100		
	Equivalent Length (EL)	70			95			125		
Total piping length	2 units (A+B+C)	50	60		85		100	115		
	3 units (A+B+C+D)	--		95		100	130			
	4 units (A+B+C+D+E+F+G)	--		95		100	145			
Maximum piping line after first branch	2 and 3 units (B, C, D)	10			15					
	4 units (B+D, B+E, C+F, C+G)	--		10		15				
Main piping length A		A > B, C, D, E, F, G								
Maximum height difference Outdoor / Indoor (H) (Outdoor Unit is Higher / Lower.)		30 / 20								
Maximum height difference Indoor / Indoor		3			10					
Maximum height difference: branch pipe/Indoor (2,3 and 4 indoor units system) branch pipe/branch pipe (4 indoor units system)		3								
(B-C) / (B-D) / (C-D) / (C+G)-(B+E) / (C+G)-(B+D) / (C+F)-(B+E) / (C+F)-(B+D)		< 8								

IVX Standard series

Outdoor Unit		3HP	4HP	5HP	6HP	8HP	10HP	12HP
Maximum piping length between the outdoor unit and the farthest indoor unit	Actual Length (L)	50	70	75		100		
	Equivalent Length (EL)	70	90	95		125		
Total piping length	2 units (A+B+C)	60	80	85		100	115	
	3 units (A+B+C+D)	--	90	95		100	130	
	4 units (A+B+C+D+E+F+G+)	--	90	95		100	145	
Maximum piping line after first branch	2 and 3 units (B, C, D)	10				15		
	4 units (B+D, B+E, C+F, C+G)	--	10		15			
Main piping length A		A > B, C, D, E, F, G						
Maximum height difference Outdoor / Indoor (H) (Outdoor Unit is Higher / Lower.)		30 / 20						
Maximum height difference Indoor / Indoor		3						
Maximum height difference: branch pipe/Indoor (2,3 and 4 indoor units system) branch pipe/branch pipe (4 indoor units system)		3						
(B-C) / (B-D) / (C-D) / (C+G)-(B+E) / (C+G)-(B+D) / (C+F)-(B+E) / (C+F)-(B+D)		< 8						



NOTE

The liquid piping and the gas piping must be of the same piping length and run along the same route.
Install the branch piping as much as possible near the indoor units
Install Multikits at the same horizontal level.

9.2.3 Piping system for line branch

OU	3 HP	4 HP	5 HP	6 HP	8 HP	10 HP	12 HP
IVX Premium	2-3	2-5	2-6		2-8		
IVX Standard	--	2-4					

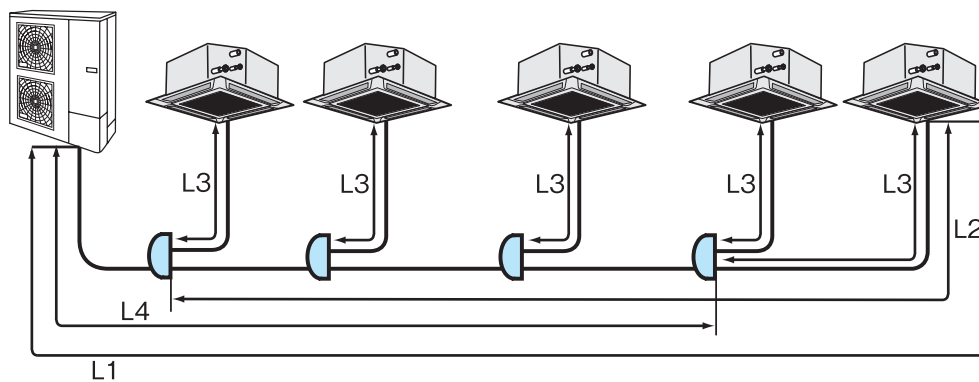

(picture is as example)

◆ **Maximum refrigerant piping length (Line branch system)**

IVX Premium series

Outdoor Unit		3HP	4HP	5HP	6HP	8HP	10HP	12HP
Maximum piping length between the outdoor unit and the farthest indoor unit	Actual Length (L1)	50	75		100			
	Equivalent Length (EL)	70	95		125			
Maximum piping length from first branch to each indoor unit (L2)		20	30		40			
Maximum piping length from branch to indoor unit (L3)		10			15			
Total piping length L4 + (L3 ₁ +L3 ₂ +L3 ₃)		60	95		100	145		
Maximum height difference Outdoor / Indoor (H) (Outdoor Unit is Higher / Lower.)		30 / 20						
Maximum height Difference Indoor / Indoor		10						
Maximum height difference: Branch pipe/Indoor Branch pipe/branch pipe		3						

IVX Standard series

Outdoor Unit		4HP	5HP	6HP	8HP	10HP	12HP	
Maximum piping length between the outdoor unit and the farthest indoor unit	Actual Length (L1)	70	75		100			
	Equivalent Length (EL)	90	95		125			
Maximum piping length from first branch to each indoor unit (L2)		20		25				
Maximum piping length from branch to indoor unit (L3)		10		15				
Total piping length L4 + (L3 ₁ +L3 ₂ +L3 ₃)		70	75		100	145		
Maximum height difference Outdoor / Indoor (H) (Outdoor Unit is Higher / Lower.)		30 / 20						
Maximum height Difference Indoor / Indoor		3						
Maximum height difference: Branch pipe/Indoor Branch pipe/branch pipe		3						

9.2.4 Combinations of piping size and piping length

IVX Premium series

Liquid	Ø6.35				Ø9.52					Ø12.70				Ø15.88			
	Ø9.52	Ø12.70	Ø15.88	Ø19.05	Ø12.70	Ø15.88	Ø19.05	Ø22.20	Ø25.40	Ø15.88	Ø19.05	Ø22.20	Ø25.40	Ø28.60	Ø22.20	Ø25.40	Ø28.60
Gas																	
Performance capacity	(m)																
2 HP	15 ⁽¹⁾	50	30	-	15 ⁽³⁾	15 ⁽³⁾	-	-	-	-	-	-	-	-	-	-	-
2.5 HP	-	50	30	-	20 ⁽³⁾	20 ⁽³⁾	-	-	-	-	-	-	-	-	-	-	-
3 HP	-	30 ⁽¹⁾⁽²⁾	30 ⁽²⁾	-	30 ⁽¹⁾	50	-	-	-	-	-	-	-	-	-	-	-
4 - 5 - 6 HP	-	-	5 ⁽²⁾	5 ⁽²⁾	40 ⁽¹⁾	75	50 ⁽⁴⁾	-	-	30 ⁽³⁾	30 ⁽³⁾⁽⁴⁾	-	-	-	-	-	-
8 HP	-	-	-	-	-	-	50 ⁽¹⁾⁽⁴⁾⁽⁶⁾	50 ⁽¹⁾⁽⁶⁾	70 ⁽⁵⁾⁽⁷⁾	-	50 ⁽¹⁾⁽³⁾⁽⁴⁾	50 ⁽¹⁾⁽³⁾	100	-	50 ⁽¹⁾⁽³⁾	50 ⁽³⁾	-
10 - 12 HP	-	-	-	-	-	-	-	-	-	-	-	50 ⁽¹⁾	100	50	50 ⁽¹⁾⁽³⁾	50 ⁽³⁾	50 ⁽³⁾

(1).Reducing gas pipe size will lower cooling capacity due to larger pressure loss in gas piping and narrow operation range.

(2).Reducing liquid pipe size will narrow operation range due to indoor unit relation with expansion valve capacity.

(3).Increasing liquid pipe size will require additional refrigerant charge.

(4).When using Ø19.05 gas pipe (soft-annealed), please switch ON DSW2-4# in the Outdoor Unit PCB.

(5) In case that pipe length exceeds 70m in 8 HP, please use a Ø12.7 pipe as a liquid pipe.

(6).In case of exceeding the recommended number of connected Indoor Units of 8 HP (more than 5 Units), please use a Ø12.7 pipe as a liquid

Standard

IVX Standard series

Liquid	Ø6.35				Ø9.52					Ø12.70				Ø15.88			
Gas	Ø9.52	Ø12.70	Ø15.88	Ø19.05	Ø12.70	Ø15.88	Ø19.05	Ø22.20	Ø25.40	Ø15.88	Ø19.05	Ø22.20	Ø25.40	Ø28.60	Ø22.20	Ø25.40	Ø28.60
Performance capacity	(m)																
3 HP	-	30 ⁽¹⁾⁽²⁾	30 ⁽²⁾	-	30 ⁽¹⁾	50	-	-	-	-	-	-	-	-	-	-	-
4 HP	-	-	5 ⁽²⁾	5 ⁽²⁾	40 ⁽¹⁾	70	50 ⁽⁴⁾	-	-	30 ⁽³⁾	30 ⁽³⁾⁽⁴⁾	-	-	-	-	-	-
5 - 6 HP	-	-	5 ⁽²⁾	5 ⁽²⁾	40 ⁽¹⁾	75	50 ⁽⁴⁾	-	-	30 ⁽³⁾	30 ⁽³⁾⁽⁴⁾	-	-	-	-	-	-
8 HP	-	-	-	-	-	-	50 ⁽¹⁾⁽⁴⁾	50 ⁽¹⁾	70 ⁽⁵⁾	-	50 ⁽¹⁾⁽³⁾⁽⁴⁾	50 ⁽¹⁾⁽³⁾	100	-	50 ⁽¹⁾⁽³⁾	50 ⁽³⁾	-
10 - 12 HP	-	-	-	-	-	-	-	-	-	-	-	50 ⁽¹⁾	100	50	50 ⁽¹⁾⁽³⁾	50 ⁽³⁾	50 ⁽³⁾

(1).Reducing gas pipe size will lower cooling capacity due to larger pressure loss in gas piping and narrow operation range.

(2).Reducing liquid pipe size will narrow operation range due to indoor unit relation with expansion valve capacity.

(3).Increasing liquid pipe size will require additional refrigerant charge.

(4).When using Ø 19.05 gas pipe (soft-annealed), please switch ON DSW2-4# in the Outdoor Unit PCB.

(5) In case that pipe length exceeds 70m in 8 HP, please use a Ø12.7 pipe as a liquid pipe.

In case of exceeding the recommended number of connected Indoor Units of 8 HP (more than 5 Units), please use a Ø12.7 pipe as a liquid

Standard

9.2.5 Refrigerant piping size and multikit/distributor

Select the piping connection sizes according to the following procedures

- Between outdoor unit and branch pipe: Select the same pipe connection size as the pipe size of the outdoor unit.
- Between branch pipe and indoor unit: Select the same pipe connection size as the pipe size of the indoor unit.

1 indoor unit system

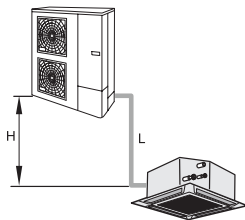

Outdoor Unit HP	Pipe Size (L)	
	Gas	Liquid
2 / 2.5	Ø12.70	Ø6.35
3 - 6	Ø15.88	Ø9.52
8	Ø25.40	Ø9.52
10/12	Ø25.40	Ø12.70

2 indoor units system

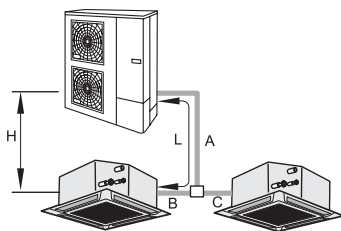

Outdoor Unit HP	Pipe Size (A)		Multi-kit	
	Gas	Liquid	IVX Premium Series	IVX Standard Series
2 / 2.5	Ø12.70	Ø6.35	TW-22AN	TE-03N1
3 / 4	Ø15.88	Ø9.52	TW-52AN	3HP: TE-03N1 4HP: TE-04N1
5 / 6	Ø15.88	Ø9.52	TW-52AN	TE-56N1
8	Ø25.40	Ø9.52 ⁽¹⁾	TW-102AN	TE-08N
10 / 12	Ø25.40	Ø12.70	TW-102AN	TE-10N

(1) In case that pipe length exceeds 70m in 8 HP, please use a Ø12.7 pipe as a liquid pipe.

Indoor Unit capacity	Pipe Size (B, C)	
	Gas	Liquid
≤ 1.5 HP	Ø12.70	Ø6.35
1.8/2.0HP	Ø15.88	Ø6.35
≥ 2.3 HP	Ø15.88	Ø9.52

Connections including Indoor Units 8 and 10 HP are not possible

3 indoor units system

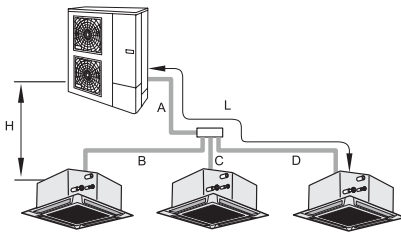

Outdoor Unit HP	(mm)		Multi-kit	
	Pipe Size (A)		IVX Premium Series	IVX Standard Series
	Gas	Liquid		
4 / 5 / 6	Ø15.88	Ø9.52	TG-53AN	TRE-46N1
8	Ø25.40	Ø9.52 ⁽¹⁾	TG-103AN	TRE-812N1
10 / 12	Ø25.40	Ø12.70	TG-103AN	TRE-812N1

(1) In case that pipe length (A+B or A+C or A+D) exceeds 70m in 8 HP, please use a Ø12.7 pipe as a liquid pipe.

Indoor Unit capacity	(mm)	
	Gas	Liquid
≤ 1.5 HP	Ø12.70	Ø6.35
1.8/2.0HP	Ø15.88	Ø6.35
≥ 2.3 HP	Ø15.88	Ø9.52

Connections including Indoor Units 8 and 10 HP are not possible

4 indoor units system

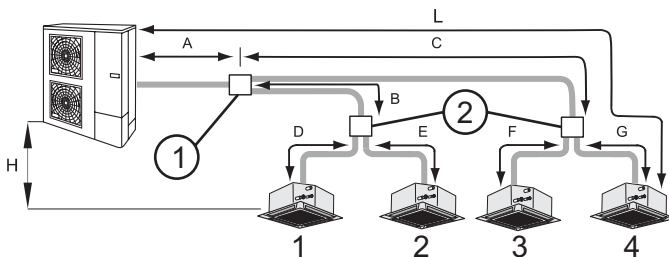

Outdoor Unit HP	(mm)		Multi-kit ①	
	Gas	Liquid	IVX Premium Series	IVX Standard Series
4 / 5 / 6	Ø15.88	Ø9.52	TW-52AN	4HP: TE-04N1 5/6HP: TE-56N1
8	Ø25.40	Ø9.52 ⁽¹⁾	TW-102AN	TE-08N QE-812N1 ⁽²⁾
10 / 12	Ø25.40	Ø12.70	TW-102AN	TE-10N QE-812N1 ⁽²⁾



(1) In case that total pipe length (A+B+D or A+B+E or A+C+F or A+C+G) exceeds of 70m in 8 HP unit, please use a Ø12.7 pipe as a liquid pipe.

(2) When is used Multi-kit model QE-812N1 it is not necessary the multi.kit 2.

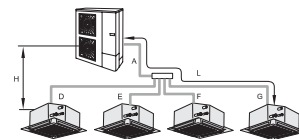

Total Indoor Unit capacity after branch pipe 1+2 or 3+4	(mm)		Multikit ②	
	Pipe Size (B,C)		IVX Premium Series	IVX Standard Series
	Gas	Liquid		
≤ 1.5 HP	Ø12.70	Ø6.35	TW-22AN	TE-03N1
from 1.8 to 2.0 HP	Ø15.88	Ø6.35	TW-52AN	TE-03N1
≥ 2.3 HP	Ø15.88	Ø9.52	TW-52AN	<4: TE-03N1 =4HP: TE-04N1 ≥ 5HP: TE-56N1

Indoor Unit capacity	Pipe Size (D,E,F,G)	
	Gas	Liquid
≤ 1.5 HP	Ø12.70	Ø6.35
1.8/2.0HP	Ø15.88	Ø6.35
≥ 2.3 HP	Ø15.88	Ø9.52

Connections including Indoor Units 8 and 10 HP are not possible

If the capacity ratio between IU group 1+2 and 3+4 is higher than 60/40% please install a line branch system or contact with your Hitachi Dealer

Line branch system

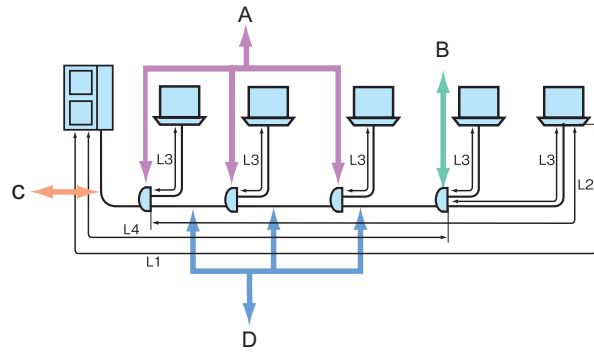

Outdoor Unit HP	(mm)		Multi-kit model A		Multi-kit model B	
	Pipe Size (C,D) (L4)		IVX Premium Series	IVX Standard Series	IVX Premium Series	IVX Standard Series
	Gas	Liquid				
3 / 4 / 5 / 6	Ø15.88	Ø9.52	E-102SN2	E-102SN2	E-102SN2	E-102SN2
8	Ø25.40	Ø9.52 ⁽¹⁾	E-162SN2	E-162SN2	E-102SN2	E-102SN2
10 / 12	Ø25.40	Ø12.70	E-162SN2	E-162SN2	E-102SN2	E-102SN2

(1) In case that total pipe length from the outdoor to the farthest indoor unit exceeds of 70m in 8 HP unit, please use a Ø12.7 pipe as a liquid pipe.

(mm)

Indoor Unit capacity	Pipe Size (L3)	
	Gas	Liquid
≤ 1.5 HP	Ø12.70	Ø6.35
1.8/2.0HP	Ø15.88	Ø6.35
≥ 2.3 HP	Ø15.88	Ø9.52

Connections including Indoor Units 8 and 10 HP are not possible

9.3 Copper pipes, sizes and connection

9.3.1 Copper pipes and sizes

- 1 Prepare locally-supplied copper pipes.
- 2 Select the pipe size of a suitable thickness and material. Use the table below to select the required piping.

Nominal diameter		Thickness (mm)	Copper type
(mm)	(in.)		
Ø6.35	1/4	0.80	Roll
Ø9.52	3/8	0.80	Roll
Ø12.70	1/2	0.80	Pipe/Roll
Ø15.88	5/8	1.00	Roll
Ø19.05	3/4	1.00	Pipe/Roll
Ø22.23	7/8	1.00	Pipe/Roll
Ø25.40	1	1.00	Pipe
Ø28.60	1 ^{1/8}	1.25	Pipe



NOTE

If copper pipe is used for piping bigger than Ø19.05, flaring work can not be performed. If necessary, use a joint adapter.

- 3 Select clean copper pipes. Make sure there is no dust and moisture inside. Blow the inside of the pipes through with oxygen-free nitrogen to remove any dust and foreign materials before connecting pipes.
- 4 After connecting the refrigerant piping, seal the open space between the knockout hole and refrigerant pipes by using insulation material as shown below:

A. Insulation.

B. Field-supplied refrigeration piping.

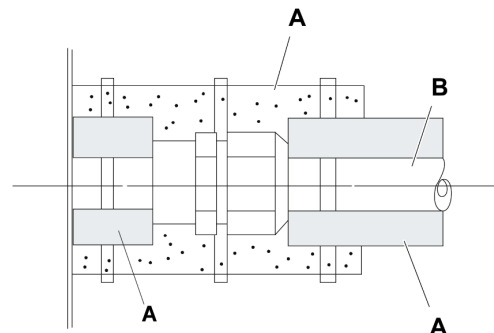

NOTE

Do not use saws, grindstone or other tools which might create copper dust.

When cutting pipes, secure the part to be soldered as shown in chapter 2 of the Service Manual (SMxx0064).

- **Strictly follow national or local regulations regarding occupational health and safety.**
- **Wear appropriate means of protection during cutting or brazing operations and installation (gloves, eye protection, etc).**

9.3.2 Pipe connection

Fix the connecting pipe as shown in the figure below. Use the insulation attached to the indoor unit.

- A. Use the flare nut of the indoor unit.
- B. Insulate this part with the insulation material supplied.
- C. Fix this part with the bracket supplied or with tape.
- D. Refrigerant piping in the installation.
- E. Field-supplied insulation.
- F. Brazing.
- G. Make flares after attaching flare nut to the connecting pipe in the Multikit package.
- H. Insulation attached to indoor unit.
- I. Indoor unit.

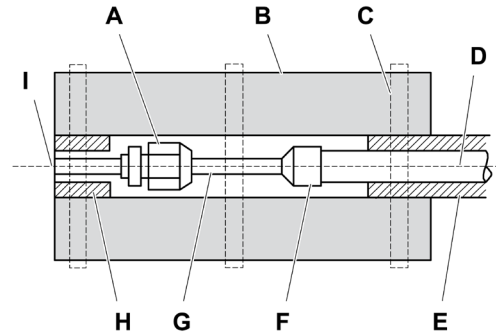

NOTE

- A system with no moisture or oil contamination will give maximum performance and life-cycle as compared with a poorly prepared system. Take particular care to ensure that all copper piping is clean and dry internally.
- To ensure this, blow oxygen free nitrogen through the pipes.



CAUTION

- Cap the end of the pipe when the pipe is to be inserted through a hole.
- Do not place pipes directly on the ground without a cap or vinyl tape covering the end, as it shown in the figure.

Right

Wrong

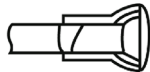

- If piping installation cannot be completed until the following day or longer, solder the ends of the piping to close them and load with oxygen-free nitrogen using an access device such as a Schrader valve to avoid moisture and contamination by extraneous particles.
- Do not use insulation material containing NH₃ as it can damage the copper piping material and may be a source of future leakage.

9.3.3 Insulation

Attach insulation package with the Multikit to each branch using vinyl tape. Also attach insulation to field-supplied piping to prevent capacity decrease due to ambient air conditions and dewing on pipe surface caused by low pressure.



NOTE

- When polyethylene foam is applied, a thickness of 10 mm for the liquid piping and from 15 mm to 20 mm for the gas piping is recommended.



CAUTION

Perform insulation work after the surface temperature decreases to the room temperature, If not, the insulation material may melt. If the ends of the piping system are open after finishing the installation work, securely attach caps or vinyl bags to the ends of the piping to prevent moisture or dust entering.

9.4 Refrigerant charge amount

Although refrigerant has been charged into this unit, additional refrigerant charge is required according to piping length.

- The additional refrigerant quantity should be determined and charged into the system according to the following procedure.
- Record the additional refrigerant quantity in order to facilitate maintenance and servicing activities.

9.4.1 Refrigerant charge before shipment (W₀ (kg))

W₀ is the outdoor unit refrigerant charge before shipment explained before, and it's shown in the following table:

IVX Premium series

Model	Refrigerant charge before shipment (W ₀ (kg))	Additional refrigerant charge (P) (g/m)	Maximum additional charge (kg)
RAS-2HVNP	1.6	30	1.5
RAS-2.5HVNP	1.6	30 (for 2 indoor units system: 24)	1.2
RAS-3HVNPE	2.3	40	1.2
RAS-4HVNPE	4.1	60	3.9
RAS-5HVNPE	4.2	60	3.9
RAS-6HVNPE	4.2	60	3.9
RAS-4HNPE	4.1	60	3.9
RAS-5HNPE	4.2	60	3.9
RAS-6HNPE	4.2	60	3.9
RAS-8HNPE	5.7	(1)	10.3
RAS-10HNPE	6.2	(1)	12.1
RAS-12HNP	6.7	(1)	12.1

IVX Standard series

Outdoor unit	Refrigerant charge before shipment (W ₀ (kg))	Additional refrigerant charge (g/m)	Maximum additional charge (kg)
RAS-3HVNC	1.9	40	1.2
RAS-4HVNCE	2.9	40	1.6
RAS-5HVNCE	2.9	60	2.7
RAS-6HVNCE	2.9	60	2.7
RAS-4HNCE	2.9	40	1.6
RAS-5HNCE	2.9	60	2.7
RAS-6HNCE	2.9	60	2.7
RAS-8HNCE	5.7	(1)	10.3
RAS-10HNCE	6.2	(1)	12.1
RAS-12HNC	6.7	(1)	12.1

(1) need to be calculated



CAUTION

- When charging refrigerant, measure the amount precisely.
- Overloading or underloading of refrigerant may cause compressor problems.
- If the actual piping length is less than 5 m consult your dealer.

9.4.2 Calculation method for the additional refrigerant charge

Calculate the additional refrigerant charge amount according to the following steps:

◆ Step 1: Additional refrigerant charge calculation for liquid piping (W₁ (kg))

Outdoor units has been charged with refrigerant for 30 m (20 m for RAS-3HVNC) of actual piping length, an additional refrigerant charged is required in systems with actual piping length longer.

For all UTOPIA units except RAS-(8-12)HN(P/C)(E)

Use the following formula:

$$W_1 = (L-30) \times P \quad (*)$$



NOTE

(*): In case of RAS-3HVNC units, the unit is charged with refrigerant for 20 m. In these cases, the formula for calculating the additional refrigerant charge is:

$$W_1 = (L-20) \times P$$

L: Total piping length (m)

P: Additional refrigerant charge (kg/m) (Refer to the Refrigerant charge before shipment chapter)

For UTOPIA units RAS-(8-12)HN(P/C)(E)

The additional refrigerant charge for **RAS-(8-12)HN(P/C)(E)** units must be calculated by multiplying the total piping length of each diameter per its calculation factor according to the following table. The result is the additional refrigerant charge for liquid piping W_1 (Fill the table with the values)

Pipe size (mm)	Additional refrigerant charge factor (kg/m)
Ø15.88	x 0.19
Ø12.7	x 0.12
Ø9.52	x 0.065
Ø6.35	x 0.065

Step 2: Additional refrigerant charge calculation for indoor unit (W_2 (kg))

When the outdoor unit is combined with indoor units RPI-(8/10)HP, it's necessary an additional refrigerant charge (W_2) = 1 kg/unit. For indoor units lower than 8 HP, an additional refrigerant charge it's not needed.

Indoor unit capacity	Additional refrigerant charge (W_2 (kg))
≥ 8 HP	1
< 8 HP	0

◆ Step 3: Calculation of total additional refrigerant charge (W (kg))

For all UTOPIA units except RAS-(8-12)HN(P/C)(E)

Put weight W_1 and W_2 calculated in step 1 and step 2 into the following formula:

$$W = W_1 + W_2$$

System example (W) = + = kg

For UTOPIA units RAS-(8-12)HN(P/C)(E)

In case of RAS-(8-12)HN(P/C)(E), it must be used the following formula:

$$W = W_1 + W_2 - C$$

System example (W) = + - = kg

C: Compensation value (kg) (Refer to the following table)

Model	Compensation value (C (kg))
RAS-8HN(P/C)E	1.6
RAS-10HN(P/E)E	2.0
RAS-12HN(P/C)	2.0



CAUTION

Do not exceed the allowed maximum additional charge

◆ **Step 4: Charging work**

Charge refrigerant (R410A) into the system according to the instructions in the Service Manual.

◆ **Step 5: Total refrigerant charge of the system (W_{TOT} (kg))**

The total refrigerant charge of this system is calculated by the following formula:

$$W_{TOT} = W + W_0$$

System example (W_{TOT}) = + = kg

W_0 is the outdoor unit refrigerant charge before shipment explained before, and it's shown in its specific table.

Finally, record the refrigerant charge quantity in order to facilitate maintenance and servicing activities.

Total additional charge W	<input type="text"/>	kg
Total ref. charge of this system	<input type="text"/>	kg
Date of ref. charge work		
Year	<input type="text"/>	Month <input type="text"/>
		Day <input type="text"/>

9.5 Caution in case of refrigerant leakage

The installers and those responsible for drafting the specifications are obliged to comply with local safety codes and regulations in the case of refrigerant leakage.

9.5.1 Maximum permitted concentration of hydrofluorocarbon (HFC)

The refrigerant R410A, charged in the UTOPIA series system, is an incombustible and non-toxic gas. However, if leakage occurs and gas fills a room, it may cause suffocation. The maximum permissible concentration of HFC gas, R410A in air is 0.44 kg/m³, according to EN378-1.

Therefore, some effective measure must be taken to lower the R410A concentration in air below 0.44 kg/m³, in case of leakage.

9.5.2 Calculation of refrigerant concentration

The room must have the following characteristics should there be a gas refrigerant leak:

- 1 Calculate the total quantity of refrigerant **R (kg)** charged in the system by connecting all the indoor units in the rooms to be air-conditioned.
- 2 Calculate the room volume **V (m³)** of each room.
- 3 Calculate the refrigerant concentration **C (kg/m³)** of the room according to the following equation:

$$C = R / V$$

R: Total quantity of refrigerant charged (kg).

V: Room volume (m³).

C: Refrigerant concentration (≤ 0.44 kg/m³ for R410A).

9.5.3 Countermeasure for refrigerant leakage

The facility must have the following features in case of a refrigerant leakage occurs:

- 1 Provide a shutterless opening which will allow fresh air to circulate into the room.
- 2 Provide a doorless opening of 0.15% or more size to the floor area.
- 3 There must be a ventilator fan connected to a gas leak detector, with a ventilator capacity of 0.4 m³/min or higher per Japanese refrigeration ton (= compressor displacement volume / 5.7 m³/h) of the air conditioning system using the refrigerant.

IVX Premium series

Model	Tonnes
RAS-2HVNP	0.88
RAS-2.5HVNP	1.14
RAS-3HVNPE	1.17
RAS-(4-6)H(V)NPE	2.27
RAS-8HNPE	3.16
RAS-(10/12)HNPE	4.11

IVX Standard series

Model	Tonnes
RAS-3HVNC	1.35
RAS-4H(V)NCE	1.64
RAS-(5/6)H(V)NCE	2.27
RAS-8HNCE	3.16
RAS-10HNCE	4.11

- 4 Pay a special attention to the place, such as a basement, etc., where refrigerant can stay, since refrigerant is heavier than air.

9.6 Compatibility with the piping of current where R22 or R407C is used.

This chapter describe the working in the pipes for compatibility with the piping of current installations where R22 or R407C is used. (Contact your Hitachi dealer for specific support on your instalation).

The new IVX Premium and IVX Standard are compatible with those installations that have been operating with R22 or R407C. This allows installing the IVX Premium/Standard Outdoor Units, which operate with R410A, without having to change piping installation.

9.6.1 Installation procedure for existing pipes



NOTE

- For systems with several indoor units, branch pipes shall be changed to Hitachi-specified model for IVX Premium and Standard (R410A).
- Existing outdoor and indoor units for R22 or R407C can not be used.

- 1 Recover refrigerant (R22 or R407C):
 - a. Compressor of the existing unit is working
Pump down. Perform refrigerant recovery operation of existing air conditioner without stopping during 30 minutes in cooling mode.
 - b. Compressor of the existing unit is not working
Recover refrigerant with a refrigerant recovery device.
- 2 Remove existing air conditioning system (Outdoor and Indoor unit).
- 3 For the existing pipes, proceed with one of the following operation:
 - a. Clean the existing piping (see section 9.6.1.1)
 - b. Connect renewal kit (optional accessory)(see section 9.6.1.2)
- 4 Connect new UTOPIA IVX Premium/Standard series
- 5 Vacuum process.
- 6 Refrigerant charge (R410A)
Follow the normal process described for determinate if it is necessary additional refrigerant charge..



CAUTION

Recovering R22 and R407C is mandatory to remove an existing air conditioner and piping. Do not vent into the atmosphere.

9.6.1.1 Conditions to use existing pipes with cleaning process

After the piping cleaning process, follow the normal installation process as if they were newly installed, considering all the restrictions and limitations. Special attention is required with regard of the piping thickness for R410A.

9.6.1.2 Conditions to use existing pipes without cleaning process

A Renewal Kit (sold separately) can be used even in cases where there is a history of Compressor failure, allowing diversion to existing piping without cleaning. Thus, the burden of installation works at renewal can be reduced.

Existing pipes can be used without cleaning if the following conditions are satisfied:

- 1 Install the Renewal kit (mandatory).
- 2 Maximum piping length 50 m. (If the pipe is longer than 50m, existing pipes can be used if cleaning is performed)
- 3 The capacity of the new unit must be equivalent at the one installed previously.
- 4 No corrosion No cracks, No scratches or deformations in existing pipes.
- 5 Dirt insider the pipes shall not be noticeable.
- 6 Piping thickness, Flare Nuts, gaskets, etc. shall be compliant products.
- 7 Flare shall be reprocessed.
- 8 Piping airtight or vacuuming shall be performed precisely as new piping.

9.6.2 When existing Air-Conditioner is a product of another manufacturer

Existing pipes made by other manufacturer can also be used if the following conditions satisfied:

- 1 For systems with several indoor units, branch pipes shall be changed to Hitachi-specified model.
- 2 Please perform a pipe cleaning.

9.6.3 Permissible range for existing Air-Conditioning Pipes (Pipe length in the case of “without cleaning process”).

IVX Premium series

Liquid	(mm)	Ø6.35				Ø9.52					Ø12.70					Ø15.88		
Thickness (mm)		0.8				0.8					0.8					1.0		
Gas	(mm)	Ø9.52	Ø12.70	Ø15.88	Ø19.05	Ø12.70	Ø15.88	Ø19.05	Ø22.20	Ø25.40	Ø15.88	Ø19.05	Ø22.20	Ø25.40	Ø28.58	Ø22.20	Ø25.40	Ø28.58
Thickness (mm)		0.8	0.8	1.0	1.0	0.8	1.0	1.0	1.0	1.0	1.0	1.0	1.0	1.0	1.0	1.0	1.0	1.0
Material Soft-annealed		x	x	x	x	x	x	x			x	x						
Material Draw					x			x	x	x		x	x	x	x	x	x	x
Performance capacity		(m)																
2 HP		15 ⁽¹⁾	50	30	-	15 ⁽³⁾	15 ⁽³⁾	-	-	-	-	-	-	-	-	-	-	-
2.5 HP		-	50	30	-	20 ⁽³⁾	20 ⁽³⁾	-	-	-	-	-	-	-	-	-	-	-
3 HP		-	30 ⁽¹⁾⁽²⁾	30 ⁽²⁾	-	30 ⁽¹⁾	50	-	-	-	-	-	-	-	-	-	-	-
4 - 5 - 6 HP		-	-	5 ⁽²⁾	5 ⁽²⁾	40 ⁽¹⁾	50	50 ⁽⁴⁾	-	-	30 ⁽³⁾	30 ⁽³⁾⁽⁴⁾	-	-	-	-	-	-
8 HP		-	-	-	-	-	-	50 ⁽¹⁾⁽⁴⁾	50 ⁽¹⁾	50	-	50 ⁽¹⁾⁽³⁾⁽⁴⁾	50 ⁽¹⁾⁽³⁾	50 ⁽³⁾	-	50 ⁽¹⁾⁽³⁾	50 ⁽³⁾	-
10 - 12 HP		-	-	-	-	-	-	-	-	-	-	-	50 ⁽¹⁾	50	50	50 ⁽¹⁾⁽³⁾	50 ⁽³⁾	50 ⁽³⁾

- (1).Reducing gas pipe size will lower cooling capacity due to larger pressure loss in gas piping and narrow operation range.
 (2).Reducing liquid pipe size will narrow operation range due to indoor unit relation with expansion valve capacity.
 (3).Increasing liquid pipe size will require additional refrigerant charge.
 (4).When using Ø 19.05 gas pipe (soft-annealed), please switch ON DSW2-4# in the Outdoor Unit PCB.

Standard

IVX Standard series

Liquid	Ø	Ø6.35				Ø9.52					Ø12.70					Ø15.88		
Thickness (mm)		0.8				0.8					0.8					1.0		
Gas		Ø9.52	Ø12.70	Ø15.88	Ø19.05	Ø12.70	Ø15.88	Ø19.05	Ø22.20	Ø25.40	Ø15.88	Ø19.05	Ø22.20	Ø25.40	Ø28.58	Ø22.20	Ø25.40	Ø28.58
Thickness (mm)		0.8	0.8	1.0	1.0	0.8	1.0	1.0	1.0	1.0	1.0	1.0	1.0	1.0	1.0	1.0	1.0	1.0
Material Soft-annealed		x	x	x	x	x	x	x			x	x						
Material Draw					x			x	x	x		x	x	x	x	x	x	x
Performance capacity		(m)																
3 HP		-	30 ⁽¹⁾⁽²⁾	30 ⁽²⁾	-	30 ⁽¹⁾	50	-	-	-	-	-	-	-	-	-	-	-
4 HP		-	-	5 ⁽²⁾	5 ⁽²⁾	40 ⁽¹⁾	50	50 ⁽⁴⁾			30 ⁽³⁾	30 ⁽³⁾⁽⁴⁾	-	-	-	-	-	-
5 - 6 HP		-	-	5 ⁽²⁾	5 ⁽²⁾	40 ⁽¹⁾	50	50 ⁽⁴⁾			30 ⁽³⁾	30 ⁽³⁾⁽⁴⁾	-	-	-	-	-	-
8 HP		-	-	-	-	-	-	50 ⁽¹⁾⁽⁴⁾	50 ⁽¹⁾	50	-	50 ⁽¹⁾⁽³⁾⁽⁴⁾	50 ⁽¹⁾⁽³⁾	50 ⁽³⁾	-	50 ⁽¹⁾⁽³⁾	50 ⁽³⁾	-
10 - 12 HP		-	-	-	-	-	-	-	-	-	-	-	50 ⁽¹⁾	50	50	50 ⁽¹⁾⁽³⁾	50 ⁽³⁾	50 ⁽³⁾

- (1).Reducing gas pipe size will lower cooling capacity due to larger pressure loss in gas piping and narrow operation range.
 (2).Reducing liquid pipe size will narrow operation range due to indoor unit relation with expansion valve capacity.
 (3).Increasing liquid pipe size will require additional refrigerant charge.
 (4).When using Ø 19.05 gas pipe (soft-annealed), please switch ON DSW2-4# in the Outdoor Unit PCB.

Standard



In case that its thickness is less than the R410A piping specifications, set DSW2, pin 4 ON. With this setting the control system adjusts the pressure in order to avoid damage to the existing pipe for R22.

9.6.4 Renewal kit selection model

Hitachi offers, as an accessory, a renewal kit:

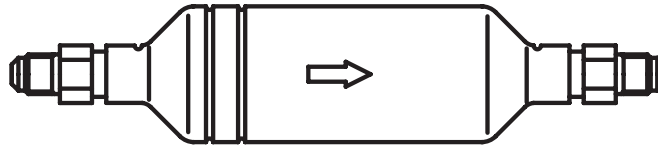

◆ Recommended renewal kit

	Renewal Kit			Renewal Kit	
IVX Premium	External Attachment to Outdoor Unit [Short Pipe (local) + Kit + Existing Piping]	Internal Attachment to Outdoor Unit [Kit + Existing Piping]	IVX Standard	External Attachment to Outdoor Unit [Short Pipe (local) + Kit + Existing Piping]	Internal Attachment to Outdoor Unit [Kit + Existing Piping]
RAS-(2/2.5)HVNP	TRF-NP63S				
RAS-3HVNP	TRF-NP160S		RAS-(3-6)H(V)NCE	TRF-NP160S	
RAS-(4-6)H(V)NPE	(TRF-NP160S)	TRF-NP160U			
RAS-8HNPE		TRF-NP280U	RAS-8HNCE		TRF-NP280U
RAS-(10/12)HNP(E)		TRF-NP335U1	RAS-(10/12)HNC(E)		TRF-NP335U1

◆ Details of renewal kit

Model	TRF-NP63S	TRF-NP160S
For liquid pipe		
For gas pipe		

O.U.: Outdoor Unit
I.U.: Indoor Unit

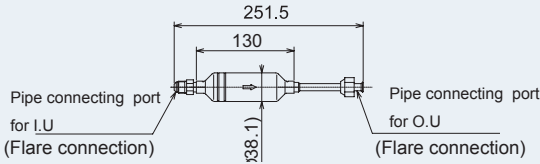
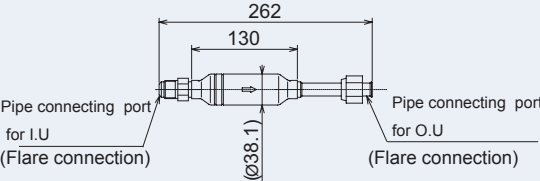
Pipe \ Model	TRF-NP160U
For liquid pipe	
For gas pipe	

O.U.: Outdoor Unit
I.U.: Indoor Unit

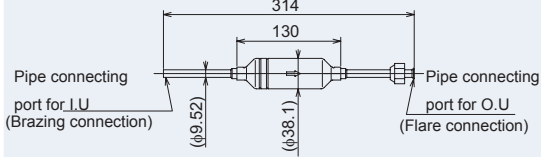
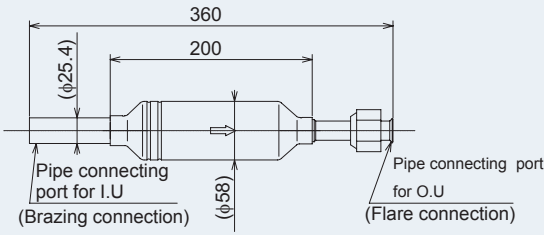
Pipe \ Model	TRF-NP280U
For liquid pipe	
For gas pipe	

O.U.: Outdoor Unit
I.U.: Indoor Unit

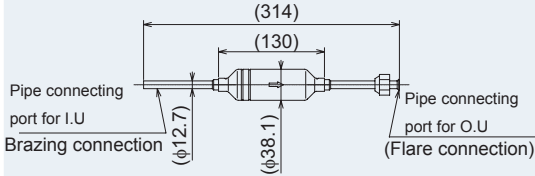
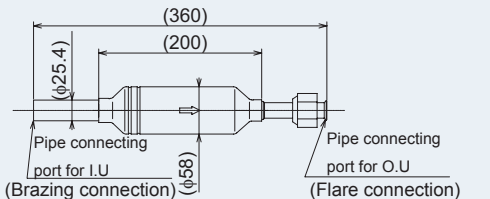
Pipe \ Model	TRF-NP335U1
For liquid pipe	
For gas pipe	

O.U. : Outdoor Unit
I.U. : Indoor Unit

◆ **Renewal kit installation (Example)**

RAS-(2/2.5)HVNP - RAS-3HVNC

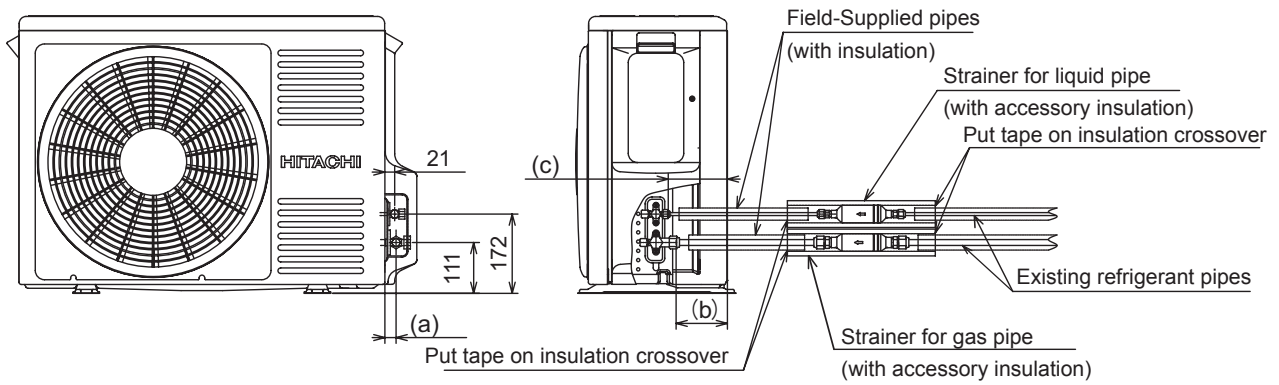

RAS-3HVNP - RAS-(4-6)H(V)NCE

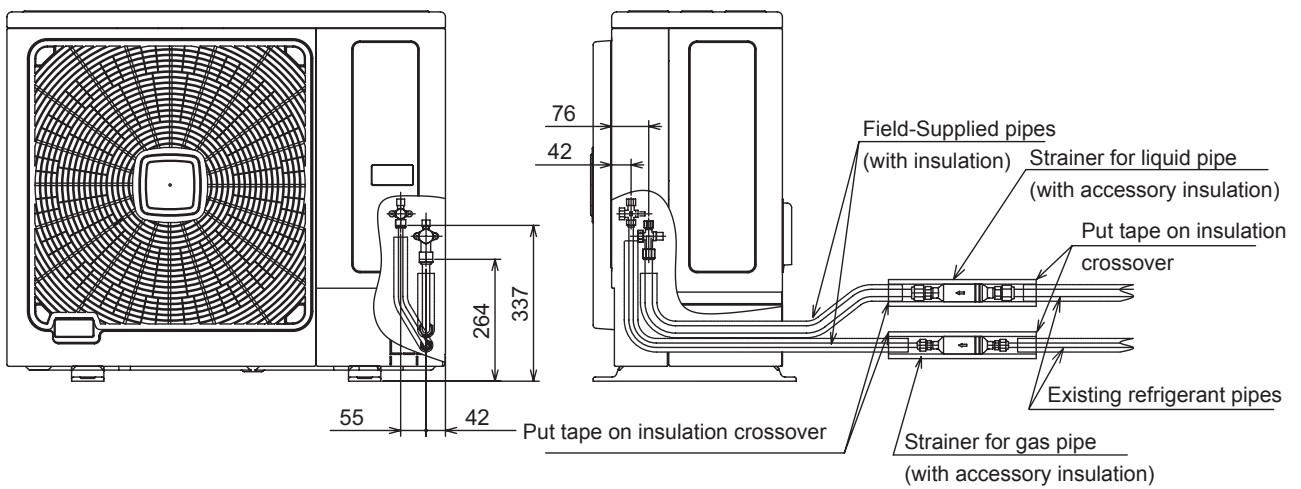

RAS-(4-6)H(V)NPE - RAS-(8/10)HN(P/C)E

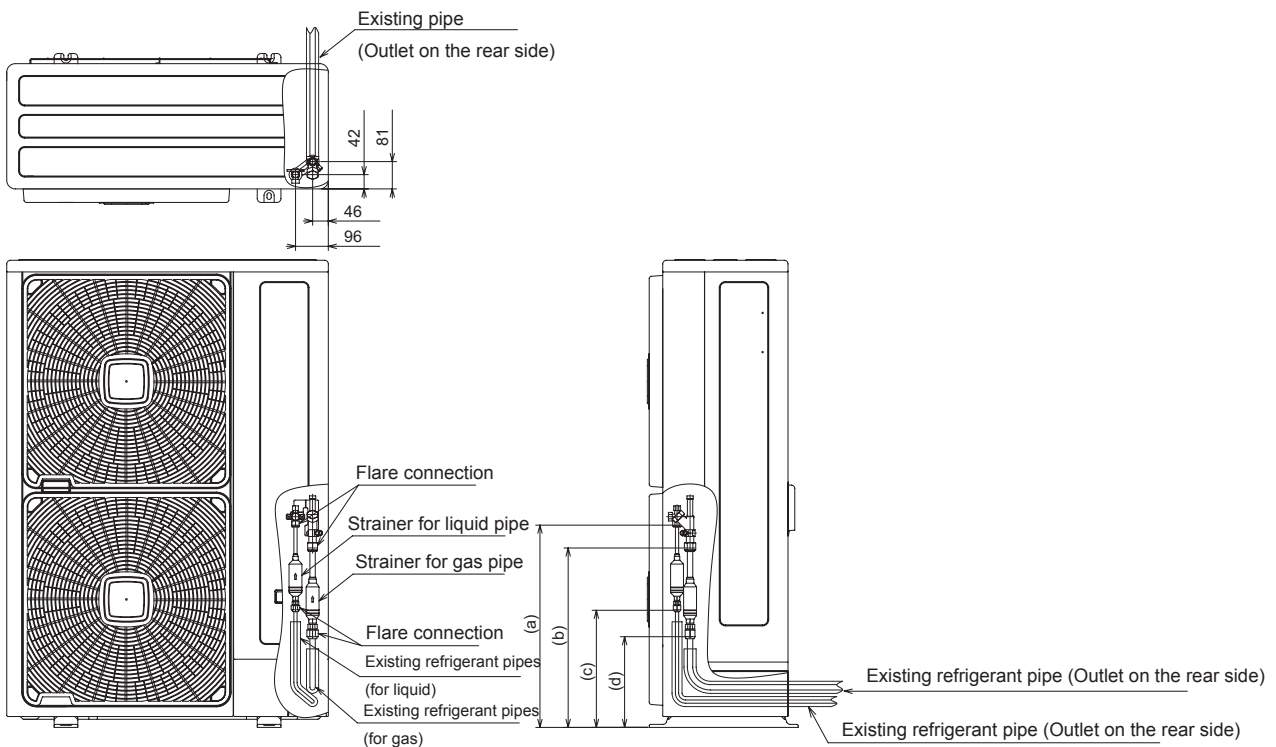

RAS-12HN(P/C)

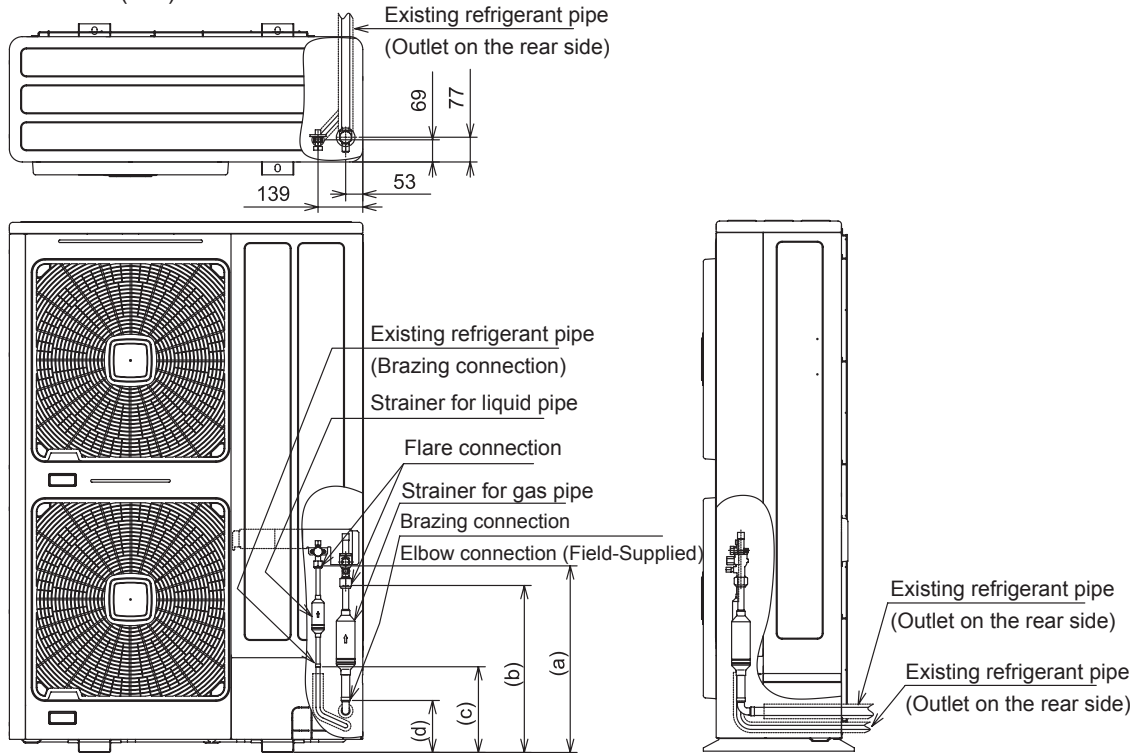

NOTE

Sizes (a) to (g) depend on the outdoor unit model

	RAS-(2/2.5)HVNP	RAS-3HVNC	RAS-(4-6)H(V)NPE	RAS-8HN(P/C)E	RAS-10HN(P/C)E	RAS-12HN(P/C)
a	22	26	581	596	578	580
b	109	103	491	497	497	521
c	129	127	329	282	264	266
d	--	--	229	137	137	161
e	--	--	46	47	--	--
f	--	--	96	98	--	--
g	--	--	81	69	--	--

10. Electrical wiring

Contents

10. Electrical wiring	131
10.1 General information.....	132
10.1.1 General notes.....	132
10.1.2 General verifications.....	132
10.2 DIP and RSW switches settings	134
10.3 Common wiring	138
10.3.1 Electrical wiring between outdoor and indoor unit.....	138
10.3.2 Wire size.....	139
10.4 H-LINK II system	140
10.4.1 Features	140
10.4.2 Specifications	140
10.4.3 DIP Switch setting for 2, 3 and 4 indoor units systems	141
10.4.4 Examples of the system of connection between H-LINK and H-LINK II units.....	142
10.4.5 Examples of H-LINK II system	143
10.5 System Control.....	145
10.5.1 Individual Operation	145
10.5.2 Simultaneous Operation.....	146

10.1 General information

10.1.1 General notes



CAUTION

- *Before any electrical wiring work or regular inspections, switch off the main power supply switches of the indoor and outdoor units. Wait three minutes before starting installation or maintenance work.*
- *Make sure that the indoor and outdoor are completely stopped before starting work on the electrical wiring or regular inspections.*
- *Protect cables, drain hose, electric parts, etc. from rodents and insects; otherwise these might damage unprotected components and, in the worst case, cause a fire.*
- *Do not allow cables to come into contact with the refrigerant pipes, metal edges, printed circuit boards (PCB) or the electric parts inside the unit; the cables may be damaged and, in the worst case, cause a fire.*
- *Firmly secure the cables inside the indoor unit with plastic flanges.*



DANGER

- *Use an earth leakage breaker with medium sensitivity, and an activation speed of 0.1 sec or less. If this is not fitted, there is a risk of electric shock and/or fire.*
- *Install an earth leakage breaker, fuse and circuit breaker for each outdoor unit power line. Not fitting it may cause an electric shock or fire.*



NOTE

- *Fix the rubber bushes with adhesive when the outdoor unit ducts are not used.*

10.1.2 General verifications

- 1 Make sure the electric components supplied by the installer (main power switches, circuit breakers, wires, connectors and connection terminals) have been selected correctly in line with the electrical data given.
 - a. The electricity supply to the unit should be via an exclusive power control switch and protective circuit breaker, certified and installed in accordance with local or national safety regulations.
 - b. The electricity supply for the outdoor and indoor units should be separate. Connect the voltage supply wiring for each group of indoor units to the same outdoor unit.
- 2 Check that the supply voltage is between 90 and 110% of the rated voltage. Where the voltage capacity is too low, it will not be possible to start the system due to the drop in voltage.
- 3 During the preliminary preparation work of the electricity supply line for the unit, the provisions in local and national legislation must never be violated.
- 4 Check that the earth cable is correctly connected.

Electromagnetic compatibility

Following Council Directive 89/336/EEC and amendments 92/31/EEC and 93/68/EEC, relating to electromagnetic compatibility, the following table indicates maximum permissible system impedance Z_{max} at the interface point of the user's power supply, in accordance with EN61000-3-11.

MODEL	Z max (Ω)	MODEL	Z max (Ω)
RAS-2HVNP	-		
RAS-2.5HVNP	-		
RAS-3HVNPE	0.39	RAS-3HVNC	-
RAS-4HVNPE	0.27	RAS-4HVNCE	0.27
RAS-5HVNPE	0.27	RAS-5HVNCE	0.27
RAS-6HVNPE	0.27	RAS-6HVNCE	0.27
RAS-4HNPE	-	RAS-4HNCE	-
RAS-5HNPE	-	RAS-5HNCE	-
RAS-6HNPE	-	RAS-6HNCE	-
RAS-8HNPE	-	RAS-8HNCE	-
RAS-10HNPE	-	RAS-10HNCE	-
RAS-12HNP	-	RAS-12HNC	-

Harmonics

Harmonics situation of each model regarding IEC 61000-3-2 and IEC 61000-3-12 is as follows:

MODELS SITUATION REGARDING IEC 61000-3-2 and IEC 61000-3-12		MODEL
Equipment complying with IEC 61000-3-2 (*) professional use		RAS-2HVNP
		RAS-2.5HVNP
		RAS-3HVNC
		RAS-4HNPE (*)
		RAS-5HNPE (*)
		RAS-6HNPE (*)
		RAS-4HNCE (*)
		RAS-5HNCE (*)
Equipment complying with IEC 61000-3-12		RAS-6HNCE (*)
		RAS-3HVNPE
		RAS-4HVNPE
		RAS-5HVNPE
		RAS-6HVNPE
		RAS-4HVNCE
This equipment complies with IEC 61000-3-12 provided that the short-circuit power Ssc is greater than or equal to xx (see Ssc column) at the interface point between the user's supply and the public system. It is the responsibility of the installer or user of the equipment to ensure, by consultation with the distribution network operator if necessary, that the equipment is connected only to a supply with a short-circuit power Ssc greater than or equal to xx (see Ssc column)		RAS-5HVNCE
		RAS-6HVNCE
Installation restrictions may be applied by supply authorities in relation to harmonics	MODEL	Ssc "xx" (KVA)
	MODEL	
		RAS-8HNPE
		RAS-8HNCE
		RAS-10HNPE
		RAS-10HNCE
	RAS-12HNP	
	RAS-12HNC	

10



DANGER

- **Never connect the earth cable to the refrigerant pipes. The gas in the pipes could cause a fire.**
- **Do not connect the earth cable to the lighting arrest system. The electrical potential of earth would increase abnormally.**

10.2 DIP and RSW switches settings

TURN OFF all power source before setting. Without turning OFF, the switches do not work and the contents of the setting are invalid.

Mark of "■" indicates the position of dip switches. Set the dip switches according to the figure below.

◆ Quantity and Position of DIP Switches

◆ RAS-(2/2.5)HVNP / RAS-3HVNC

The PCB in the outdoor unit is operating with 7 types of DIP switches, and 4 push switch. The location is as follows:

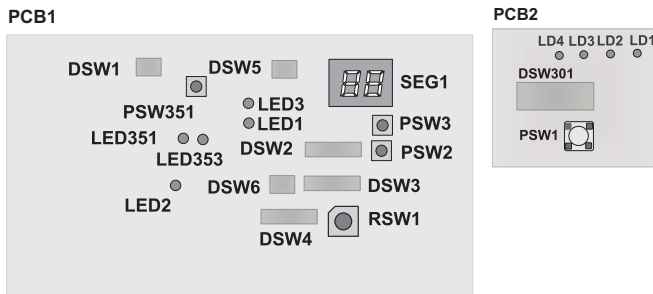

◆ RAS-(3-6)H(V)N(P/C)E

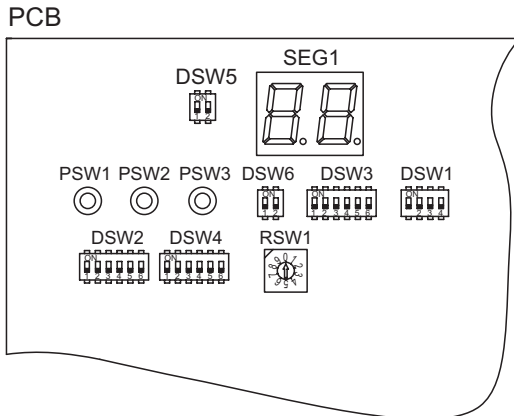

◆ RAS-(8-12)HN(P/C)(E)

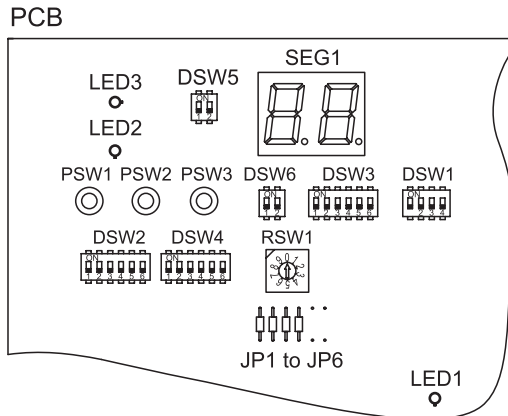

◆ DSW301 (Only RAS-(2/2.5)HVNP and RAS-3HVNC units): Test run mode



◆ DSW1 (Only RAS-(2/2.5)HVNP and RAS-3HVNC units): No setting is required

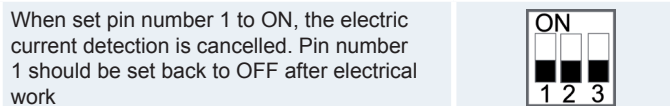

◆ **DSW1 (RAS-(3-12)H(V)N(P/C)(E): For Test Run**







Factory setting	
Cooling	
Heating	
Cooling for intermediate season	
Heating for intermediate season	
Forced stop of compressor	

◆ **DSW2: Pipe length setting (setting is required) / Optional function setting**

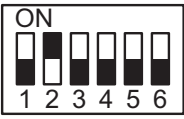
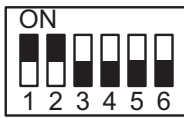
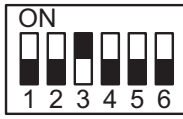
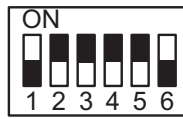
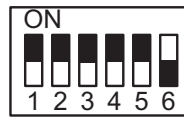
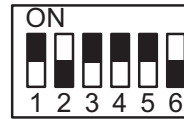
Pipe length setting should be performed as follows according to the on-site pipe length.	Setting before shipment	
	Pipe length (≤5m)	
	Pipe length (≥30m)	
	Optional piping setting	
Optional function setting		
External input/output setting mode		

◆ **DSW3: Capacity setting (no setting is required)**

Factory setting

RAS-2HVNP 	RAS-2.5HVNP 	RAS-3HVN(P/C)E 	RAS-4HVN(P/C)E 	RAS-5HVN(P/C)E 	RAS-6HVN(P/C)E 
RAS-4HN(P/C)E 	RAS-5HN(P/C)E 	RAS-6HN(P/C)E 	RAS-8HN(P/C)E 	RAS-10HN(P/C)E 	RAS-12HN(P/C) 

◆ **DSW4 / RSW1: Refrigerant cycle number setting (Setting is required)**

Setting for the ten digit
(Factory setting)



Setting position.
Set by inserting slotted screwdriver into the groove (setting for the last digit)



◆ **DSW5: End terminal resistance (No setting is required)**

Factory setting



Cancellation
(Setting of end terminal resistance)

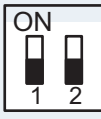

i **NOTE**

Setting for transmission

It is required to set the outdoor unit number refrigerant cycle and end terminal resistance for the H-LINK.

In the same refrigerant cycle, set the same refrigerant cycle number for the outdoor unit and the indoor units.

Example incase of setting before cycle number 25

DSW4: Turn ON pin number 2

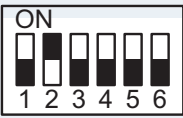

RSW1: set dial number 5



In case that the outdoor units quantity in the same H-LINK II is 2 or more, set in the DSW5 the pin number 1 OFF side from the second refrigerant group outdoor units. If only one outdoor unit is used (in the same H-Link II system), no setting is required.

Turn OFF DSW5 No.1 pin for cancel of end terminal resistance setting.

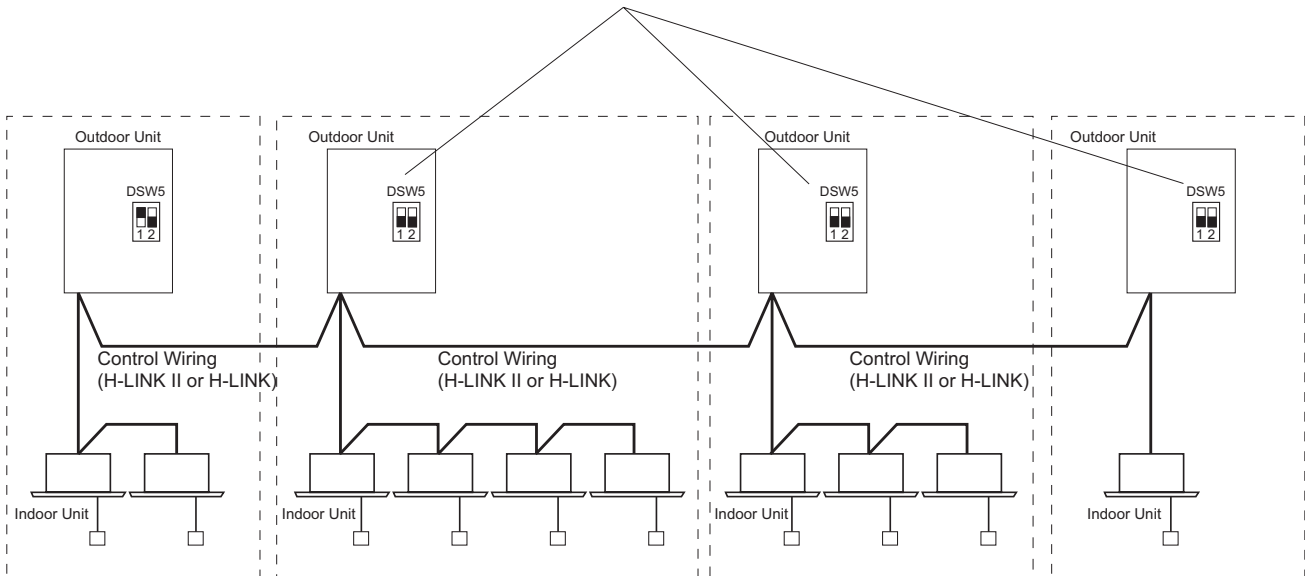

◆ **DSW6: Setting of multiple indoor units operation (setting is required)**

Optional function setting	For individual operation (factory setting)
	For simultaneous operation
	Set pin number 1 at OFF for simultaneous operation

Wiring Example

Basic Combinations
(In the case of Twin Combination)

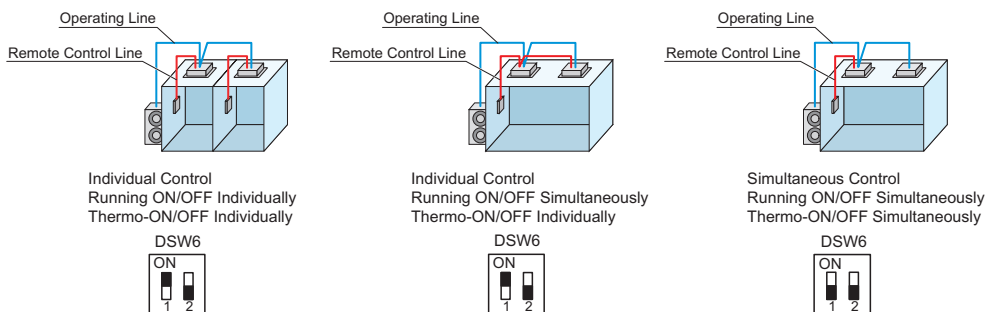

10.3 Common wiring

10.3.1 Electrical wiring between outdoor and indoor unit

- Connect the electrical wires between the indoor unit and the outdoor unit as show in the figure.
- When installing the electrical wiring, follow local codes and regulations.
- The refrigerant piping and the control wiring are connected to the units in the same refrigerant cycle.
- Use twist pair wire (more than 0.75 mm²) for operation wiring between the outdoor unit and indoor unit, and operation wiring between indoor unit and indoor unit.
- Use a 2-core wire for the operating line (do not use wire with more than 3 cores).
- Use shielded wires for intermediate wiring to protect the units from noise interference at lengths of less than 300 m. The size must comply with local code.
- Open a hole near the connection hole of power source wiring when multiple outdoor units are connected from a single power source line.
- The recommended breaker sizes are detailed in the Wire size section.
- In the case that a conduit tube for field-wiring is not used, fix rubber bushes with adhesive on the panel.
- All field wiring and equipment must comply with local and international codes.
- H-LINK twist pair shielded cable must be grounded in the outdoor unit side.



NOTE

- **Take care with the connection of the operating line. Incorrect connection may cause a failure of the PCB.**

Power source from the outdoor unit to the indoor unit

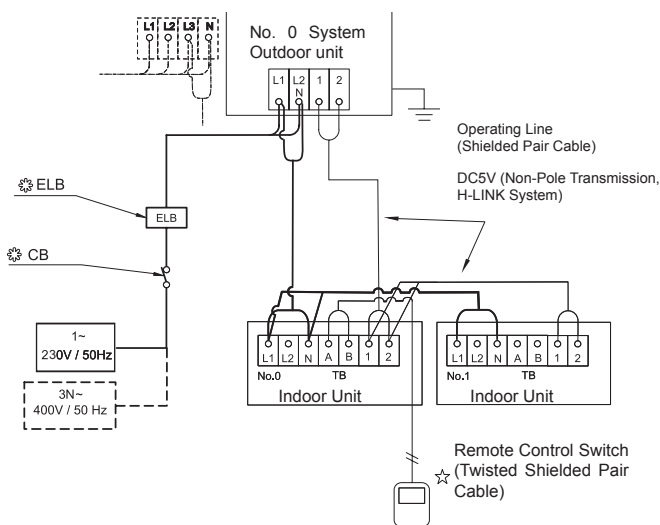

- TB Terminal board
- CB Circuit Breaker
- ELB Earthleakage Breaker
- Field Wiring
- Field supplied
- ☆ Optional Accessory

Independent power source of outdoor unit and indoor unit

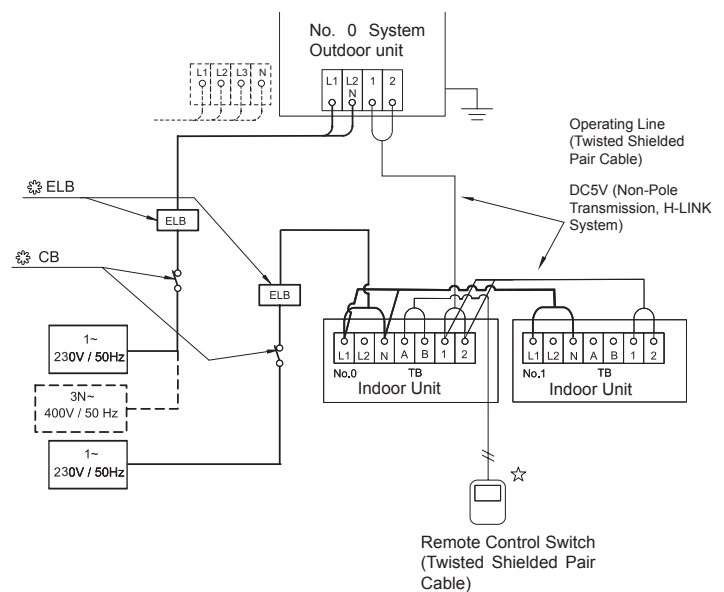

TB: Terminal board

CB: Circuit breaker (field supplied)

ELB: Earthleakage breaker (field supplied)

A: Power source from the outdoor unit to the indoor unit

10.3.2 Wire size

◆ Connection wiring

Recommended minimum sizes for field provided wires:

Model	Power supply	Power source cable size	Transmitting cable size
		EN60 335-1	EN60 335-1
All Indoor Units	1~ 230V 50HZ	0.75 mm ²	0.75 mm ²
IVX Premium Series			
RAS-2HVNP	1~ 230V 50HZ	2.5 mm ²	
RAS-2.5HVNP		4.0 mm ²	
RAS-3HVNPE		6.0 mm ²	
RAS-4HVNPE			
RAS-5HVNPE			
RAS-6HVNPE			
RAS-4HNPE	3N~ 400V 50Hz	2.5 mm ²	
RAS-5HNPE		6.0 mm ²	
RAS-6HNPE			
RAS-8HNPE			
RAS-10HNPE			
RAS-12HNP			
IVX Standard Series			
RAS-3HVNC	1~ 230V 50HZ	4.0 mm ²	
RAS-4HVNCE		6.0 mm ²	
RAS-5HVNCE			
RAS-6HVNCE			
RAS-4HNCE	3N~ 400V 50Hz	4.0 mm ²	
RAS-5HNCE			
RAS-6HNCE			
RAS-8HNCE		6.0 mm ²	
RAS-10HNCE			
RAS-12HNC			



NOTE

- Follow local codes and regulations when selecting field wires, Circuit breakers and Earth Leakage breakers
- Use the wires which are not lighter than the ordinary polychloroprene sheathed flexible cord (code designation H05RN-F)

10.4 H-LINK II system

The H-LINK II is the wiring connection system between units.

The H-LINK II wiring system only needs:

- Two transmission wires connecting each indoor and outdoor unit for a total of 64 refrigerant cycles.
- Connection wiring for all indoor and outdoor units in series.



CAUTION

- *The H-LINK II system cannot be applied to the models with the old cycle, nor to units with an old transmission.*

10.4.1 Features

- The total wiring length is considerably reduced compared to traditional connections.
- Only one connection is required for the wiring between the indoor and outdoor units.
- The wiring connection of the complementary central control devices is easy.



NOTE

- *CSNET WEB is centralized control system which allows the installation to be controlled remotely. It can be connected at any point of the local corporate network, or even via the Internet.*

10.4.2 Specifications

A: outdoor unit.

B: indoor unit.

C: a refrigerant cycle.

D: transmission cables.

E: refrigerant piping.

- Transmission cable: 2-wire.
- Polarity of transmission cable: non-polar wire.
- Maximum number of indoor units that can be connected: 4 units per cycle and 160 units per H-LINK II system.
- Maximum wiring length: total 1000 m (including CSNET WEB).
- It is possible to increase the maximum wiring length up to 5000 m by using up to four PSC-5HR units.
- Recommended cable: shielded twisted pair cable, over 0.75 mm² (Equivalent to KPEV-S).
- Voltage: 5 V DC.

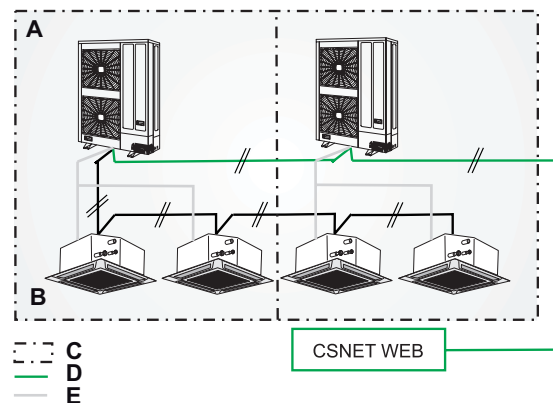

CAUTION

- *For the H-LINK II system must use twisted shielded pair cable or shielded pair cable.*

10.4.3 DIP Switch setting for 2, 3 and 4 indoor units systems



Dip switch of indoor PCB and outdoor H-LINK II

The DIP switches of all the indoor and outdoor units have to be set and the impedance of the transmission circuit adapted.

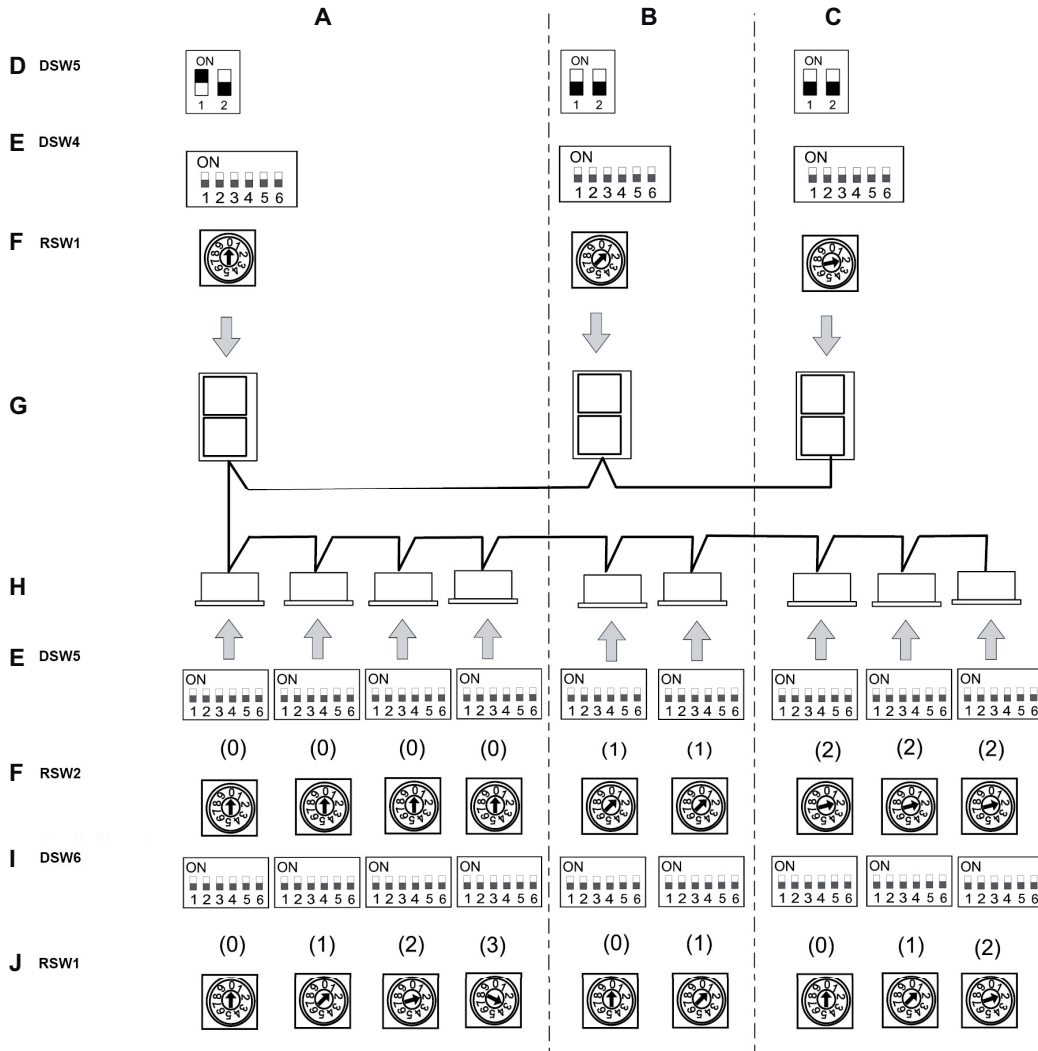
- Example of the setting of the DIP switches.

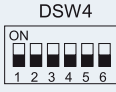
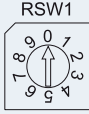

- A: Cycle No. 0.
- B: Cycle No. 1.
- C: Cycle No. 2.
- D: Terminal resistance.
- E: No. of refrigerant cycle (setting for the tenth digit).
- F: No. of refrigerant cycle (setting for the last digit).
- G: Outdoor units.
- H: Indoor units.
- I: Address of the indoor unit (setting for the tenth digit).
- J: Address of the indoor unit (setting for the tenth digit).

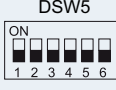
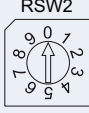
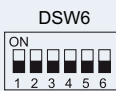
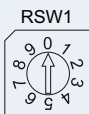
Unit	Name of DIP switch	Mark	Setting before the Shipment	Function
Outdoor Unit	Refrigerant cycle	DSW4 RSW1	 	For setting the refrigerant cycle address of the outdoor unit. Set the DSW4 and RSW1 to overlap the setting of other outdoor units in the same H-LINK system.
	Resistance of terminal	DSW5		To adapt the impedance of the transmission circuit, adjust DSW5 according to the number of outdoor units of the H-LINK system.
Indoor Unit	Refrigerant cycle	DSW5 RSW2	 	For setting the refrigerant cycle address of the indoor unit. Set the DSW5 and RSW2 corresponding to the address of outdoor unit in the same refrigerant cycle.
	Address of the indoor unit	DSW6 RSW1	 	Setting indoor unit address. Set the DSW6 and RSW1 not to overlap the setting of other indoor units in the same refrigerant cycle. (If no set, the automatic address function is performed.)

10.4.4 Examples of the system of connection between H-LINK and H-LINK II units

In the case of mixed systems with H-LINK and H-LINK II, set the H-LINK units in the first 16 position of the system, as in the following example where 42 systems are connected, 16 with indoor FSN1E units and 26 with indoor FSN2E units.

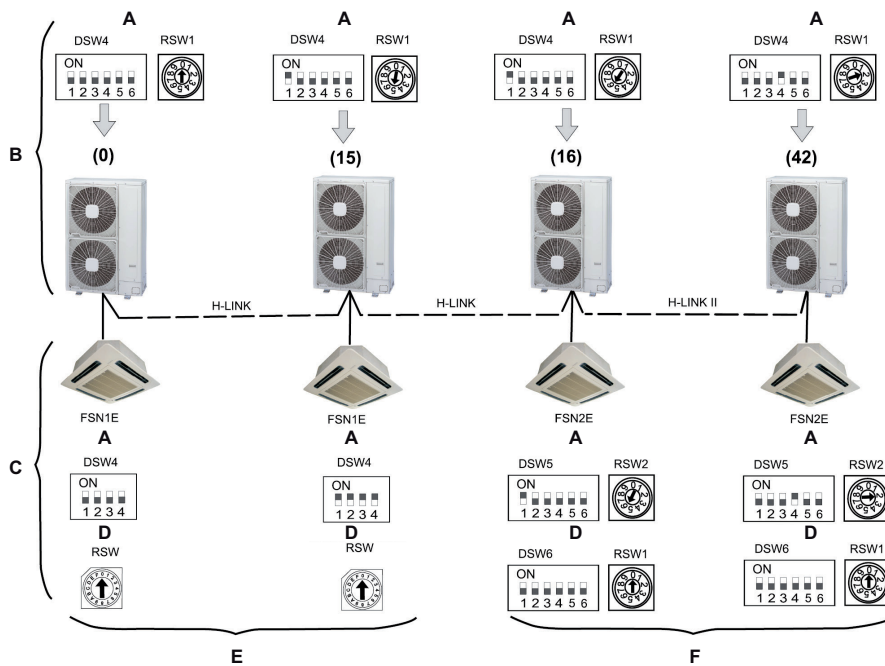

- A: Refrigerant cycle.
- B: Outdoor unit.
- C: Indoor unit.
- D: Indoor unit address.
- E: Either the current remote control switch (H-LINK) or the new one (H-LINK II) can be used.
- F: Only the new remote control switch (H-LINK II) can be used.



NOTE

- The maximum number of indoor units than an H-LINK II can control is 160.
- If you use PSC-5S and the CSNET WEB 2.0 (systems only compatible with H-LINK) bear in mind that it will only recognize 16 indoor and 16 outdoor units.

10.4.5 Examples of H-LINK II system

Two cases:

1. Using H-LINK II system for air conditioning systems without a central control device (CSNET WEB or PSC-A64S).

- Line connection with all units (including Utopia and/or Set Free, Mini Set Free and DC Inverter).

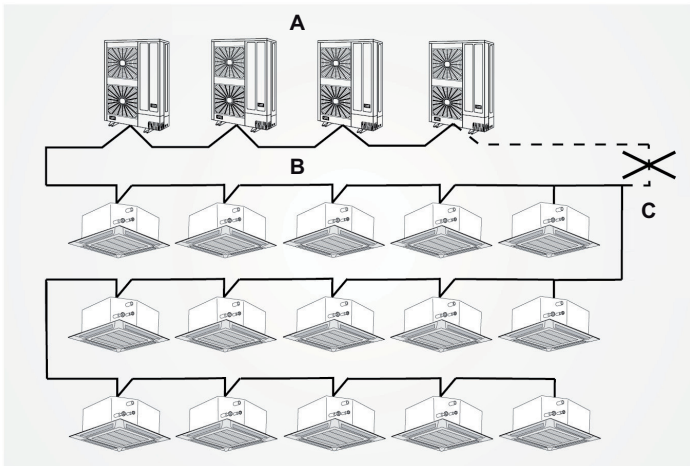

A: Outdoor units.

B: Indoor units.

C: Do not install wiring in a loop.

- Line connection for each floor.

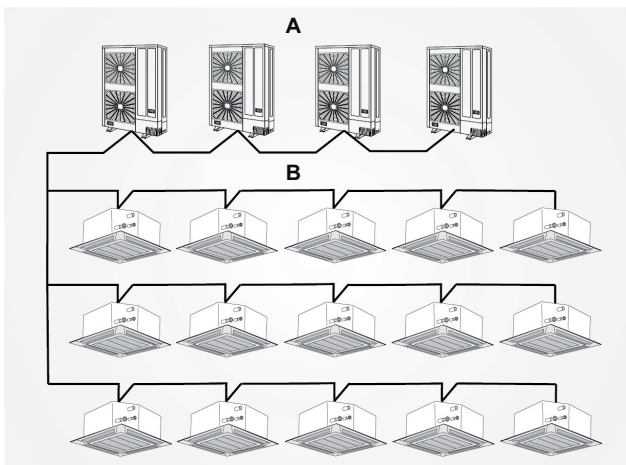

A: Outdoor units.

B: Indoor units.

- Connection with one main line and with the branch lines for the units.

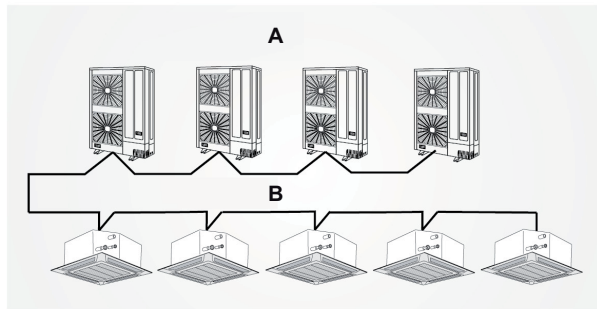

A: Outdoor units.

B: Indoor units.

CAUTION

- *The maximum number of units that can be connected is 64 outdoor units and 160 indoor units (including Utopia and/or Set Free, Mini Set-free).*
- *Do not install the wiring in a loop.*
- *If the H-LINK II system is not used when carrying out the electrical wiring as shown above, it must be used once the wiring of the instrument is completed. The DIP switches must therefore be set as specified in the DIP switches on the PCB.*

2. Using the H-LINK II system for air conditioning systems with a central control device (CSNET WEB or PSC-A64S)

- If the central control device is used when carrying out electrical wiring, the CS-NET WEB can be connected at any point of the H-LINK II wiring.

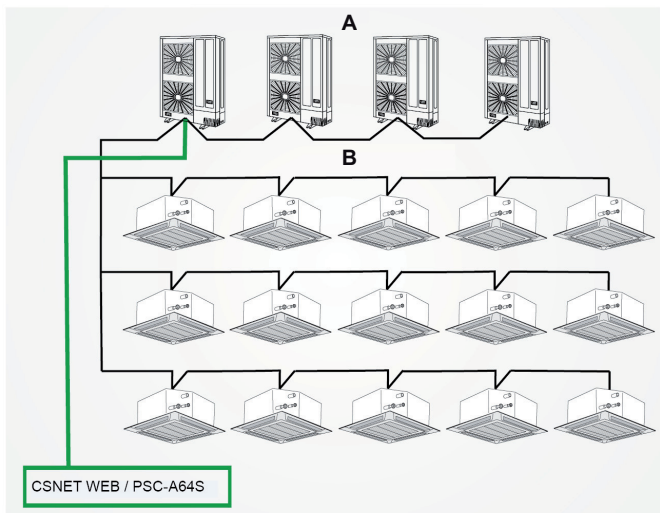

A: Outdoor units.

B: Indoor units.

- If the central control device is not used when electrical wiring is carried out, you must connect the H-LINK II wiring to all the systems. The easiest method is usually to connect the outdoor units.

NOTE

- *For CSNET WEB 2.0 the limitations are those corresponding to H-LINK.*

10.5 System Control

10.5.1 Individual Operation

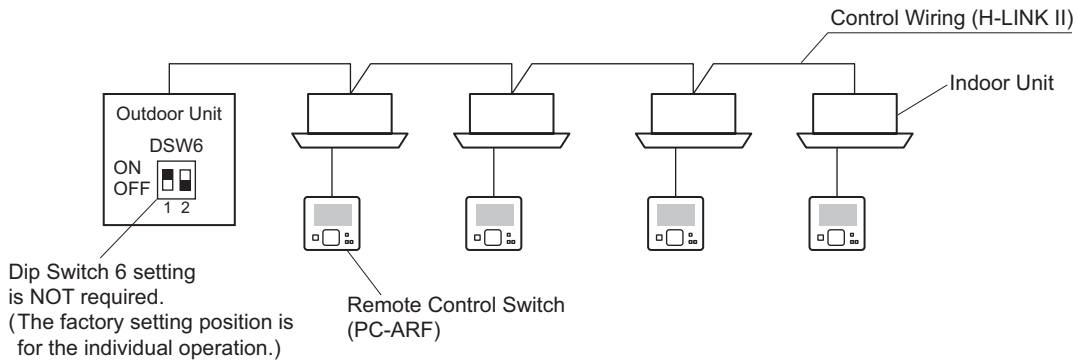

◆ Individual Thermo ON/OFF Operation

The individual Thermo ON/OFF is available to be controlled each indoor unit even if multiple indoor units are controlled simultaneously by one remote control switch.

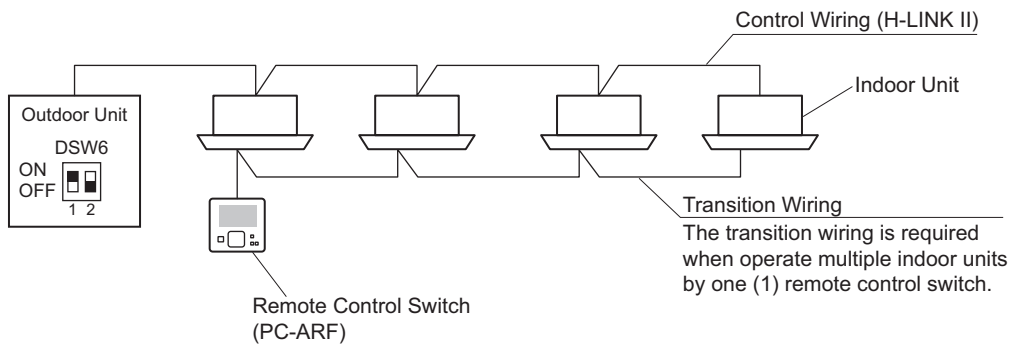

Control Method	by each optional remote control switch	
Operation Method	by one group	
(1) ON/OFF	Yes	
(2) Setting of Operation Mode	Yes	*1)
(3) Room Temperature Setting	Yes	
(4) Fan Speed Setting	Yes	
(5) Timer Setting	Yes	
(6) ON/OFF by Timer Control	Yes	
(7) Operation Indication	Yes	
(8) Alarm Indication	Yes	
(9) Self-Checking	Yes	
(10) Test Mode	Yes	
(11) Individual Louver Setting	Yes	*2)
(12) Motion Sensor Setting	Yes	*3)

- Yes : Available
- *1) : Cooling and heating can not be operated simultaneously.
- *2) : Only for RCI-FSN3 series with PC-ARF
- *3) : Only for RCI-FSN3 + P-AP160NAE + PC-ARF
Do not mix other indoor unit, air panel (P-AP160NA1) and remote control switch (PC-ART) if set from one remote control switch.

10.5.2 Simultaneous Operation

This unit can be operated simultaneously with 2, 3 and 4 indoor units combinations.

One remote control switch (PC-ARF) can control without transition wiring up to 4 units of FSN2 series or later model types (H-LINK II supported models) simultaneously (Available if it is with the transition wiring.)

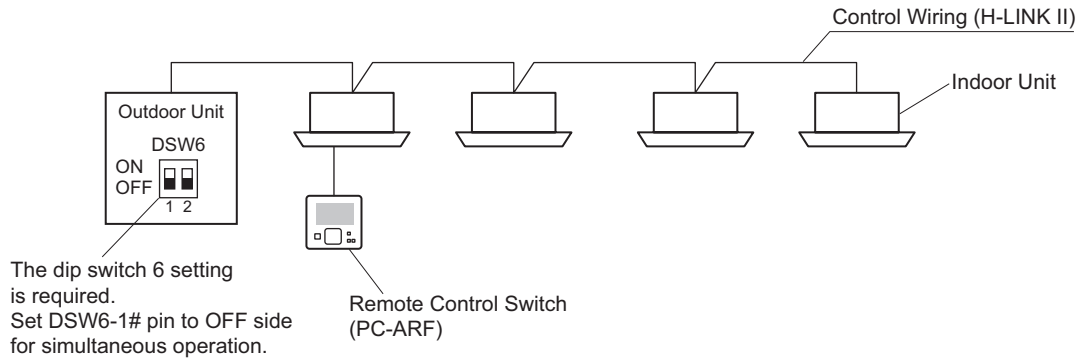

Control Method	by one optional Remote Control Switch	
Operation Method	by one group	
(1) ON/OFF	Yes	
(2) Setting of Operation Mode	Yes	*1)
(3) Room Temperature Setting	Yes	
(4) Fan Speed Setting	Yes	
(5) Timer Setting	Yes	
(6) ON/OFF by Timer Control	Yes	
(7) Operation Indication	Yes	
(8) Alarm Indication	Yes	
(9) Self-Checking	Yes	
(10) Test Mode	Yes	
(11) Individual Louver Setting	Yes	*2)
(12) Motion Sensor Setting	Yes	*3)

- Yes : Available
- *1) : Only if all units in one group are connected to the same outdoor unit.
- *2) : Only for RCI-FSN3 series with PC-ARF
- *3) : Only for RCI-FSN3 + P-AP160NAE + PC-ARF
Do not mix other indoor unit, air panel (P-AP160NA1) and remote control switch (PC-ART) if set from one remote control switch.

11. Troubleshooting

Contents

11. Troubleshooting.....	147
11.1 On-screen displays during abnormal operation.....	148
11.1.1 PC-ARF Troubleshooting help menu.....	148
11.2 Alarm codes	150

11.1 On-screen displays during abnormal operation

Abnormal operation can be produced due to the following reasons:

- Malfunction

The RUN (red) indicator flashes.

The ALARM indicator appears on the liquid crystal display.

The screen also displays the following items:

- A: indoor unit address.
- B: Refrigerant cycle number.
- C: Alarm code.
- D: Model code.
- E: If there are various indoor units connected, the above mentioned information is shown for each one of them.

Write down the indications and contact your HITACHI service supplier.

- Power supply failure.

All displays disappear.

If the unit stops due to a power shortage, it will not start again, even though the power comes back on. Carry out the start-up operations again.

If the power failure lasts less than 2 seconds, the unit will start again automatically.

- Electrical noise

The displays can disappear from the screen and the unit can stop. This is because the microcomputer has been activated to protect the unit from electrical noise.



NOTE

If the wireless remote control is used for the wall-type indoor unit, remove the connectors (CN25) that are connected to the indoor PCB. Otherwise the unit will not work. The stored data cannot be erased unless the remote control is initialised.

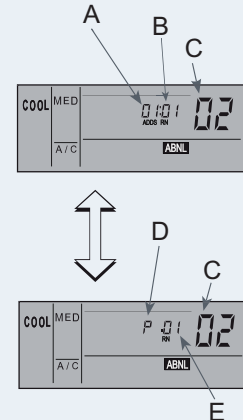

(PC-ART example)

Model code	
Indication	Model
H	Heat pump
P	Inverter
F	Multi (SET-FREE)
┌	Cooling only
E	Other
b	IVX, individual operation
L	KPI

11.1.1 PC-ARF Troubleshooting help menu

PC-ARF remote controller have a Troubleshooting function in Help Menu.

Make sure that the troubleshooting is read carefully before requesting for repairs. Select "Troubleshooting" from the help menu and press "OK". The list of troubleshooting will be displayed.

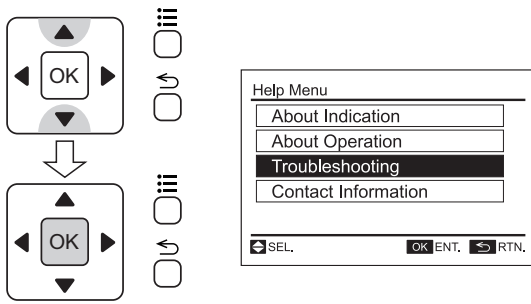

1 Select a problem from the list by pressing “Δ” or “∇” and press “OK”. The details of the selected problem will be displayed.

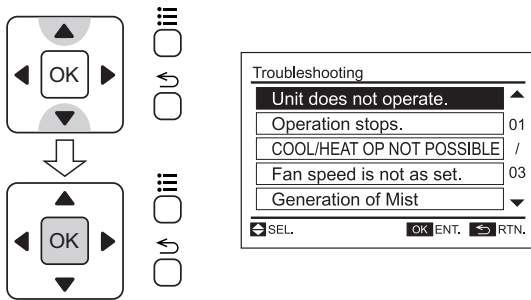

2 Press “Δ” or “∇” to scroll the text up and down.

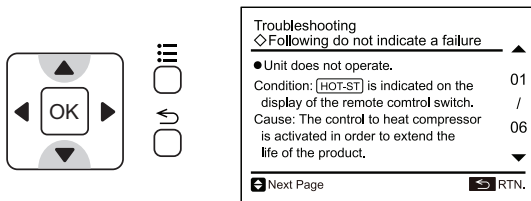

3 Press “↵” (return). The screen will return to the list of troubleshooting.

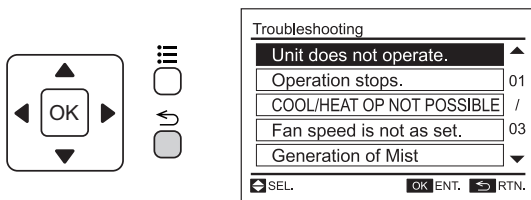

4 Press “↵” (return). The screen will return to the help menu.

To return to the normal mode, press “↵” (return) again.

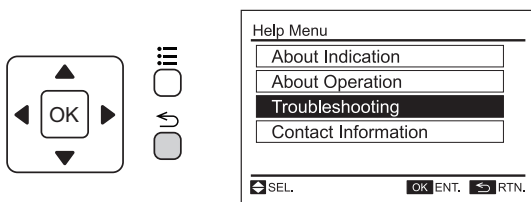

11.2 Alarm codes

Code number	Category	Abnormality	Cause
01	Indoor unit	Activation of the safety device	Failure of fan motor, drain discharge, PCB, relay, float switch activated
02	Outdoor unit	Activation of the safety device	Failure of fan motor, drain discharge, PCB, relay, float switch activated
03	Transmission	Abnormal transmission between outdoor and indoor units	Incorrect wiring, failure of PCB, tripping of fuse, power supply OFF
04		Abnormal transmission between inverter PCB (DIP-IPM) and outdoor unit PCB (PCB1)	Abnormal transmission between PCB
05	Power supply	Abnormal operation of picking up phase signal	Main power supply phase is reversely connected or one phase is not connected.
06	Voltage	Excessively low voltage or excessively high voltage for the inverter	Incorrect wiring or insufficient capacity of power supply wiring
07	Cycle	Decrease in discharge gas superheat	Discharge gas superheat less than 10 degrees is maintained for 30 minutes.
08		Excessively high discharge gas temperature at the top of compressor	Temperature of top compressor: Td Td > 132°C over 10 minutes, or Td >140°C over 5 minutes
11	Sensor on indoor unit	Air inlet thermistor	Failure of thermistor, sensor, connection.
12		Air outlet thermistor	
13		Freeze protection thermistor	
14		Gas piping thermistor	
16	Sensor on indoor unit	Remote thermistor	Failure of thermistor
17		Thermistor of RCS	Failure of thermistor
19		Activation of the protection device for the indoor fan motor	Failure of fan motor
20	Sensor on outdoor unit	Compressor thermistor	Failure of thermistor, sensor, connection.
21		High pressure sensor	Incorrect wiring, disconnected wiring, broken cable, short circuit.
22		Thermistor for outdoor ambient temperature (THM7)	Failure of thermistor, sensor, connection.
23		Thermistor for discharge gas temperature (THM9)	Incorrect wiring, disconnected wiring, broken cable, short circuit.
24		Thermistor for evaporating temperature (THM8)	Failure of thermistor, sensor, connection.
29		Low pressure sensor	Incorrect wiring, disconnected wiring, broken cable, short circuit.
31	System	Incorrect capacity setting or combined capacity between outdoor and indoor units	Incorrect setting of the capacity code.
35		Incorrect indoor unit number setting	Duplication of indoor unit number , number of indoor units over specifications.
36		Incorrect indoor unit combination	R22 indoor unit
38		Abnormality of picking up circuit for protection (Outdoor unit)	Failure of indoor unit PCB, incorrect wiring, connection to PCB in indoor unit.

Code number	Category	Abnormality	Cause
41	Pressure	Cooling overload (possible activation of high pressure device)	O.U. pipe thermistor temp. is higher than 55 °C and the compressor top temp. is higher than 95 °C, O.U. protection device is activated.
42		Heating overload (high-pressure device may be activated)	If I.U. freeze protection thermistor temp. is higher than 55 °C and compressor top temp. is higher than 95 °C, O.U. protection device is activated.
43		Activation of the safety device from compression ratio decrease	Abnormal compress (Compressor, Inverter damage)
44		Activation of the safety device from excessively high suction pressure	Overload during cooling, high temperature with heating, locked expansion valve
45		Activation of the safety device from excessively high discharge pressure	Overload (obstruction of HEX, short circuit) mixture of inert gas
47		Activation of the safety device from excessively low suction pressure (protection from vacuum operation)	Shortage or leakage of refrigerant, piping clogging, expansion valve close-locked, fan motor locked.
48	Inverter	Abnormality of current sensor for inverter	Failure of DIP-IPM, heat exchanger clogged, locked compressor, EVI/EVO failure or overcharge.
51		Abnormality of Current Sensor for Inverter	Failure of control PCB, inverter module.
53		Protection activation of inverter module	Inverter module abnormality. Failure of compressor, clogging of heat exchanger.
54		Inverter fin temperature increase	Abnormal inverter fin thermistor, clogging of heat exchanger, abnormal outdoor fan.
55		Inverter Module abnormality	Failure of inverter module.
57	Outdoor fan	Fan Motor abnormality	Disconnected wire of incorrect wiring between control PCB and inverter PCB. Incorrect wiring or fan motor abnormality.
b1	Indoor unit number setting	Incorrect setting of the unit and the refrigerant cycle number.	Over 64 indoor units setting by number or indoor unit address.
b5		Incorrect indoor unit connection number setting	There are more than 17 units not corresponding to H-Link II connected to one system
EE	Compressor	Compressor protection	Failure of compressor.

Hitachi Air Conditioning Products Europe, S.A.
Ronda Shimizu, 1 - Polig. Ind. Can Torrella
08233 Vacarisses (Barcelona) Spain



Hitachi certifies that our products have met EU consumer safety, health and environmental requirements.



Hitachi Air Conditioning Products Europe, S.A. is certified with:
ISO 9001 of AENOR, Spain for its Quality Management accordance with the standard
ISO 14001 of AENOR Spain for its Environmental Management systems accordance with the standard



Hitachi air conditioning products are manufactured according to:
ISO 9001 of JQA, Japan for its Quality Management accordance with the standard
ISO 14001 of JACO, Japan for its Environmental Management accordance with the standard



HITACHI participates in the Eurovent Certification Programme; the certified data of certified models are listed in the Eurovent Certification Online Directory (www.eurovent-certification.com).