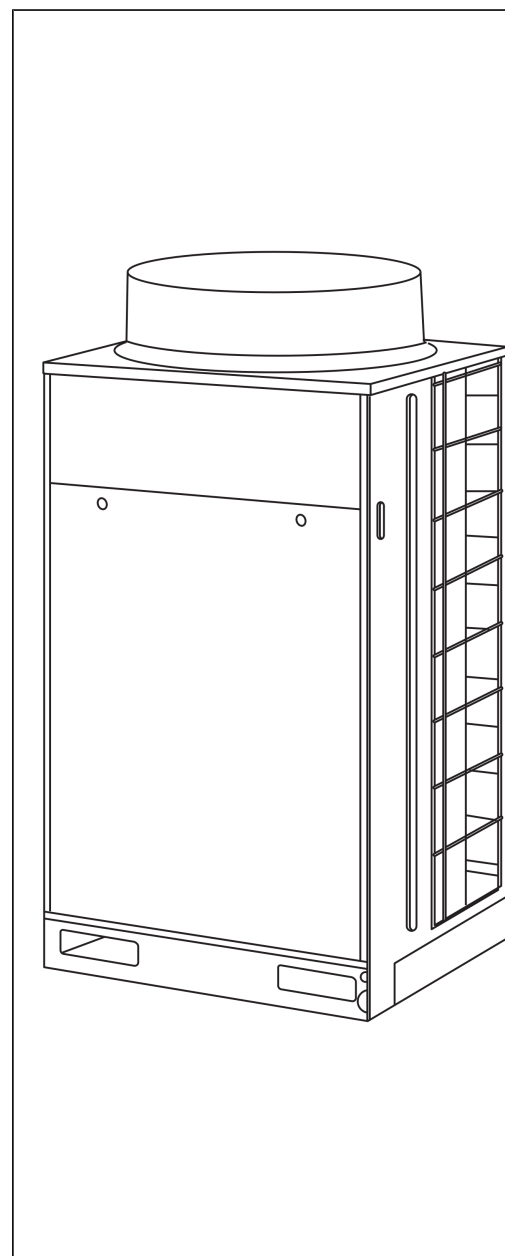


SET FREE SERIES  
FSXN

Technical Catalogue

---

RAS-8FSXN	RAS-30FSXN	RAS-52FSXN
RAS-10FSXN	RAS-32FSXN	RAS-54FSXN
RAS-12FSXN	RAS-34FSXN	
RAS-14FSXN	RAS-36FSXN	
RAS-16FSXN	RAS-38FSXN	
RAS-18FSXN	RAS-40FSXN	
RAS-20FSXN	RAS-42FSXN	
RAS-22FSXN	RAS-44FSXN	
RAS-24FSXN	RAS-46FSXN	
RAS-26FSXN	RAS-48FSXN	
RAS-28FSXN	RAS-50FSXN	





## Index

<b>1</b>	<b>General information.....</b>	<b>1</b>
1.1	General information.....	2
1.1.1	Copyright.....	2
1.1.2	Introduction.....	2
1.1.3	Environment-friendly units.....	2
1.2	Safety.....	3
1.2.1	Symbols used.....	3
1.3	Product guide.....	4
1.3.1	Classification of outdoor unit models.....	4
1.3.2	Product guide: Outdoor units.....	4
1.3.2.1	RAS outdoor units.....	4
1.3.2.2	Combination of outdoor units.....	5
1.3.3	Accessory code list.....	6
<b>2</b>	<b>Features and benefits.....</b>	<b>7</b>
2.1	Benefits of the choice.....	9
2.1.1	Choice range.....	9
2.1.1.1	Wide range of outdoor units.....	9
2.1.1.2	System configuration.....	9
2.1.1.3	Range of accessories.....	11
2.1.3	Flexible system.....	12
2.1.3.1	SET FREE system: combination of different outdoor units.....	12
2.1.3.2	SYSTEM FREE system: combination of different indoor units.....	13
2.1.3.3	Unit management through the range of remote controls.....	13
2.1.4	Availability of the Hi-Tool Kit selection software.....	13
2.1.4.1	Assisted air conditioning installation design.....	13
2.1.4.2	Variable installation capacity.....	14
2.2	Installation benefits.....	15
2.2.1	Outdoor units.....	15
2.2.1.1	Main features of the installation.....	15
2.2.1.2	Compact design that makes it easier to install.....	17
2.2.1.3	Easy and flexible pipe installation.....	18
2.2.1.4	Flexibility to expand the installation.....	19
2.2.1.5	Flexibility to branch out the pipes.....	19
2.2.1.6	High number of connectable inside units.....	21
2.2.2	Optional parts.....	21
2.2.2.1	CH units.....	21
2.2.3	Easy and flexible communication between units.....	22
2.2.3.1	H-LINK II bus.....	22
2.3	Start-up benefits.....	29
2.3.1	Automatic start-up.....	29
2.3.1.1	Test run and identification of the system units.....	29
2.3.1.2	Test run from the remote control.....	29
2.3.1.3	Test run from the outdoor unit.....	30

2.3.2	Service verification.....	30
2.3.2.1	System operation control.....	30
2.3.2.2	Assisted-management air conditioning system.....	30
2.3.2.3	Compilation of operating data.....	30
2.3.3	Automatic system to estimate the amount of refrigerant charged in the unit.....	30
2.4	Functional benefits.....	32
2.4.1	General features.....	32
2.4.1.1	Greater efficiency.....	32
2.4.1.2	Reduced power consumption.....	32
2.4.2	Multiple capacity control.....	32
2.4.3	Individual management capacity with a minimum of 0.8 HP.....	32
2.4.4	Silent compressor.....	32
2.4.5	Silent fan.....	33
2.4.6	Highly efficient refrigerant cycle.....	33
2.4.7	DC Inverter Scroll Compressor.....	34
2.4.8	Low noise level for compressor.....	35
2.4.9	Efficiency.....	35
2.4.10	Inverter Control.....	35
2.4.11	Total reduced capacity for the outside unit.....	36
2.4.12	Wide range of operating possibilities.....	38
2.4.13	Night mode (optional function).....	38
2.4.14	Emergency (backup) function.....	39
2.4.15	Outdoor unit rotation function.....	40
2.4.16	Control over operating values (optional function).....	41
2.5	Maintenance benefits.....	42
2.5.1	Access cover for installation and maintenance.....	42
2.5.2	Availability of maintenance tools.....	42
2.5.2.1	HITACHI Service Tools.....	42
2.5.2.2	Monitoring the system and simplifying maintenance work.....	42
2.5.2.3	Decrease in operation costs.....	42
2.6	Simple maintenance.....	43
2.6.1	Optimised design to simplify maintenance.....	43
2.6.2	Minimum or zero maintenance.....	43
2.6.3	Loyal to the HITACHI philosophy.....	43
<b>3</b>	<b>General data.....</b>	<b>45</b>
3.1	General data.....	46
3.1.1	Outdoor units.....	46
3.1.1.1	General conditions.....	46
3.1.1.2	RAS-(8-12)FSXN.....	47
3.1.1.3	RAS-(14-18)FSXN.....	48
3.1.1.4	RAS-(20-24)FSXN.....	49
3.1.1.5	RAS-(26-30)FSXN.....	50
3.1.1.6	RAS-(32-36)FSXN.....	51
3.1.1.7	RAS-(38-42)FSXN.....	52
3.1.1.8	RAS-(44-48)FSXN.....	53
3.1.1.9	RAS-(50-54)FSXN.....	54
3.1.1.10	CH-(6.0-10.0)N1.....	55

3.2	Component data.....	56
3.2.1	Outdoor units RAS-(8-54)FSXN.....	56
3.3	Electrical data.....	60
3.3.1	Considerations.....	60
3.3.2	Outdoor units RAS-(8-54)FSXN.....	60
<b>4</b>	<b>System selection procedure.....</b>	<b>61</b>
4.1	Selection guide.....	62
4.2	Selection procedure.....	65
4.2.1	Cooling mode.....	66
4.2.2	Heating mode.....	69
4.3	Nominal cooling capacity tables.....	71
4.4	Nominal heating capacity tables.....	95
4.5	Outdoor unit capacity with total horsepower of combined indoor unit.....	120
4.6	Tables for 100% combination cooling capacity.....	136
4.7	Tables for 100% combination heating capacity.....	145
4.8	Correction factor depending on the pipe length.....	158
4.9	Correction factor depending on defrost.....	162
4.10	Sensible heat factor (SHF).....	163
4.11	Compatibility.....	165
4.11.1	Examples of different H-LINK and H-LINK II systems.....	165
<b>5</b>	<b>Acoustic characteristic curves.....</b>	<b>169</b>
5.1	Overall sound level.....	170
5.2	Outdoor units RAS-(8-54)FSXN.....	171
<b>6</b>	<b>Working range.....</b>	<b>177</b>
6.1	Voltage supply.....	178
6.2	Working range.....	179
<b>7</b>	<b>General dimensions.....</b>	<b>181</b>
7.1	Dimensions RAS-(8-12)FSXN.....	182
7.2	Dimensions RAS-(14-18)FSXN.....	183
7.3	Dimensions CH-(6.0-10.0)N1.....	184
7.4	Service space.....	185
<b>8</b>	<b>Refrigerant cycle.....</b>	<b>187</b>
8.1	RAS-(8-12)FSXN.....	188
8.2	RAS-(14-18)FSXN.....	189
8.3	CH-(6.0-10.0)N1.....	190
<b>9</b>	<b>Piping work and refrigerant charge.....</b>	<b>191</b>
9.1	Refrigerant pipe selection.....	192
9.1.1	Pipe size selection.....	192
9.2	Copper pipes, sizes, connection and insulation.....	193
9.2.1	Copper pipes and sizes.....	193
9.2.2	Pipe connection.....	193

9.3	Pipe connection kit.....	195
9.3.1	SET FREE FSXN (two pipes).....	195
9.3.2	SET FREE FSXN (three pipes).....	196
9.4	Multi-Kits.....	199
9.4.1	2-pipe Multi-Kit (Optional Parts).....	199
9.4.2	3-pipe Multi-Kit (Optional Parts).....	199
9.5	Precautions for the installation of the outdoor unit.....	201
9.6	Provision of pipes.....	203
9.7	Connection of refrigerant pipes for heat pump (2 pipes).....	204
9.7.1	Pipe sizes for RAS-(8-18)FSXN (Base unit).....	204
9.7.2	Pipe sizes for RAS-(20-36)FSXN (Combination of two units).....	204
9.7.3	Pipe sizes for RAS-(38-54)FSXN (Combination of three units).....	205
9.7.4	Pipe connection kit (optional).....	206
9.7.5	Example of installation (38 HP: 2 pipes).....	206
9.7.6	Size of pipes (ø mm) and selection of multikit (2 pipes).....	207
9.8	Connection of refrigerant pipes for heat recovery (3 pipes).....	210
9.8.1	Pipe sizes for RAS-(8-18)FSXN (Base unit).....	210
9.8.2	Pipe sizes for RAS-(20-36)FSXN (Combination of two units).....	210
9.8.3	Pipe sizes for RAS-(38-54)FSXN (Combination of three units).....	211
9.8.4	Pipe connection kit (optional).....	212
9.8.5	Example of installation (38 HP: 3 pipes).....	213
9.8.6	Size of pipes (ø mm) and selection of multikit (3 pipes).....	213
9.9	Refrigerant charge.....	218
9.9.1	Installation airtight test.....	218
9.9.2	Installation vacuum.....	219
9.9.3	Quantity of refrigerant charged in the W0 outdoor unit.....	219
9.9.4	Maximum additional refrigerant charge.....	219
9.9.5	Method of calculation of the total additional refrigerant charge.....	219
9.9.6	Refrigerant charge.....	220
9.9.7	Automatic system to estimate the amount of refrigerant charged in the unit.....	221
9.10	Precautions in the event of refrigerant leaks.....	223
9.10.1	Maximum permitted concentration of hydrofluorocarbon (HFC).....	223
9.10.2	Calculation of the refrigerant concentration.....	223
9.10.3	Countermeasures in the event of refrigerant leaks.....	224
<b>10</b>	<b>Electrical wiring.....</b>	<b>225</b>
10.1	General information.....	226
10.2	General verifications.....	227
10.3	Setting of the DSW switches on PCB1.....	228
10.4	Shared wiring between outdoor and indoor units.....	231
10.4.1	Connection of outdoor units.....	231
10.4.2	Connection of indoor units.....	232
	10.4.2.1 Connection diagram: heat pump system.....	234
	10.4.2.2 Connection diagram: heat recovery system.....	235
10.5	Connection of the power supply circuits.....	236
10.5.1	Cable sizes.....	236
10.5.2	Main breaker switch.....	236

<b>11</b>	<b>Optional functions.....</b>	<b>237</b>
11.1	Optional functions available for outdoor units.....	238
<b>12</b>	<b>Location of problems.....</b>	<b>239</b>
12.1	On-screen displays during abnormal operation.....	240
12.2	Alarm codes.....	241





# 1. General information

## Index

1.1	General information.....	2
1.1.1	Copyright.....	2
1.1.2	Introduction.....	2
1.1.3	Environment-friendly units.....	2
1.2	Safety.....	3
1.2.1	Symbols used.....	3
1.3	Product guide.....	4
1.3.1	Classification of outdoor unit models.....	4
1.3.2	Product guide: Outdoor units.....	4
1.3.2.1	RAS outdoor units.....	4
1.3.2.2	Combination of outdoor units.....	5
1.3.3	Accessory code list.....	6

## 1.1 General information

---

### 1.1.1 Copyright

© Copyright 2010 HITACHI Air Conditioning Products Europe, S.A. – All rights reserved.

No part of this publication may be reproduced, copied, filed or transmitted in any shape or form without the permission of HITACHI Air Conditioning Products Europe, S.A.

Within the policy of continuous improvement of its products, HITACHI Air Conditioning Products Europe, S.A. reserves the right to make changes at any time without prior notification and without being compelled to introducing them into products subsequently sold. This document may therefore have been subject to amendments during the life of the product.

HITACHI makes every effort to offer correct, up-to-date documentation. Despite this, printing errors cannot be controlled by HITACHI and are not its responsibility.

As a result, some of the images or data used to illustrate this document may not refer to specific models. No claims will be accepted based on the data, illustrations and descriptions included in this manual.

No type of modification must be made to the equipment without prior, written authorisation from the manufacturer.

### 1.1.2 Introduction

HITACHI presents the FSXN series, which belongs to the SET FREE series characterised by its modular design. Use of just one unit, known as the base unit (8 ~ 18 HP), or the combination of two or up to three of these base units with different powers allows for the remaining range of air conditioning capacities (20 ~ 54 HP) to be covered in office buildings and small industry.

The modular concept of the FSXN series offers refrigeration, heating or both simultaneously, to create personalised environments for every necessity.

### 1.1.3 Environment-friendly units

The new range of HITACHI outdoor units uses environment-friendly R410A gas refrigerant and applies RoHS and Green Dot standards throughout the production and installation process to reflect HITACHI's awareness of environmental respect and commitment.



## 1.2 Safety

### 1.2.1 Symbols used

During normal air conditioning system design work or unit installation, greater attention must be paid in certain situations requiring particular care in order to avoid injuries and damage to the unit, the installation or the building or property.

Situations that jeopardise the safety of those in the surrounding area or that put the unit itself at risk will be clearly indicated in this manual.

To indicate these situations, a series of special symbols will be used to clearly identify these situations.

Pay close attention to these symbols and to the messages following them, as your safety and that of others depends on it.



#### **DANGER**

- *The text following this symbol contains information and instructions relating directly to your safety and physical wellbeing.*
- *Not taking these instructions into account could lead to serious, very serious or even fatal injuries to you and others in the proximities of the unit.*

In the texts following the danger symbol you can also find information on safe procedures during unit installation.



#### **CAUTION**

- *The text following this symbol contains information and instructions relating directly to your safety and physical wellbeing.*
- *Not taking these instructions into account could lead to minor injuries to you and others in the proximities of the unit.*
- *Not taking these instructions into account could lead to unit damage.*

In the texts following the caution symbol you can also find information on safe procedures during unit installation.



#### **NOTE**

- *The text following this symbol contains information or instructions that may be of use or that require a more thorough explanation.*
- *Instructions regarding inspections to be made on unit parts or systems may also be included.*

## 1.3 Product guide

### 1.3.1 Classification of outdoor unit models

Unit type (outdoor unit): RAS

Position-separating hyphen (fixed)

Capacity (HP): (8-54)

FSX: SET FREE

N: R410A refrigerant

XXX

-

XX

FSX

N

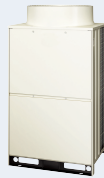
### 1.3.2 Product guide: Outdoor units

#### ◆ RAS outdoor units

##### RAS FSXN outdoor units



##### RAS FSXN



##### Outdoor unit

Unit	Code
RAS-8FSXN	60288346
RAS-10FSXN	60288347
RAS-12FSXN	60288348
RAS-14FSXN	60288349
RAS-16FSXN	60288350
RAS-18FSXN	60288351



#### NOTE

To obtain the different operating range powers, please refer to the chapter [Combination of outdoor units](#), see on page 5.

### ◆ Combination of outdoor units

The power range of the RAS-(8-54)FSXN outdoor units is obtained by applying one unit (RAS-(8-18)FSXN) or by the combination of two or three outdoor units (RAS-(8-18)FSXN), depending on the instructions in the following tables.

#### Base units

HP	8	10	12	14	16	18
Model	RAS-8FSXN	RAS-10FSXN	RAS-12FSXN	RAS-14FSXN	RAS-16FSXN	RAS-18FSXN

#### Combination of base units

HP	20	22	24	26	28	30
Model	RAS-20FSXN	RAS-22FSXN	RAS-24FSXN	RAS-26FSXN	RAS-28FSXN	RAS-30FSXN
Combination	RAS-8FSXN	RAS-8FSXN	RAS-10FSXN	RAS-12FSXN	RAS-14FSXN	RAS-14FSXN
	RAS-12FSXN	RAS-14FSXN	RAS-14FSXN	RAS-14FSXN	RAS-14FSXN	RAS-16FSXN
HP	32	34	36	38	40	42
Model	RAS-32FSXN	RAS-34FSXN	RAS-36FSXN	RAS-38FSXN	RAS-40FSXN	RAS-42FSXN
Combination	RAS-16FSXN	RAS-16FSXN	RAS-18FSXN	RAS-12FSXN	RAS-12FSXN	RAS-12FSXN
	RAS-16FSXN	RAS-18FSXN	RAS-18FSXN	RAS-12FSXN	RAS-12FSXN	RAS-12FSXN
	–	–	–	RAS-14FSXN	RAS-16FSXN	RAS-18FSXN
HP	44	46	48	50	52	54
Model	RAS-44FSXN	RAS-46FSXN	RAS-48FSXN	RAS-50FSXN	RAS-52FSXN	RAS-54FSXN
Combination	RAS-12FSXN	RAS-12FSXN	RAS-12FSXN	RAS-14FSXN	RAS-16FSXN	RAS-18FSXN
	RAS-14FSXN	RAS-16FSXN	RAS-18FSXN	RAS-18FSXN	RAS-18FSXN	RAS-18FSXN
	RAS-18FSXN	RAS-18FSXN	RAS-18FSXN	RAS-18FSXN	RAS-18FSXN	RAS-18FSXN

1

### 1.3.3 Accessory code list

HITACHI offers a range of different accessories and remote control systems that can be used with the SET FREE outdoor units. Please consult the corresponding Technical Catalogue for controls.

Name	Description	Code	Figure
MC-20AN	Branch pipe (pipe kit)	70526009	
MC-21AN	Branch pipe (pipe kit)	70526010	
MC-30AN	Branch pipe (pipe kit)	70526011	
MC-20XN	Branch pipe (pipe kit)	70526109	
MC-21XN	Branch pipe (pipe kit)	70526110	
MC-30XN	Branch pipe (pipe kit)	70526111	
CH-6.0N1	CH Unit	60291633	
CH-10.0N1	CH Unit	60291634	
DBS-TP10A	Drain Boss	60291683	-
E-102SN2	Branch pipe (multikit)	70524001	
E-162SN2	Branch pipe (multikit)	70524002	
E-242SN2	Branch pipe (multikit)	70524004	
E-302SN2	Branch pipe (multikit)	70524005	
E-52XN2	Branch pipe (multikit)	70525000	
E-102XN2	Branch pipe (multikit)	70525001	
E-162XN2	Branch pipe (multikit)	70525002	
E-202XN2	Branch pipe (multikit)	70525003	
E-242XN2	Branch pipe (multikit)	70525004	
E-322XN2	Branch pipe (multikit)	70525005	
MH-84AN	Distributor	70522007	
MH-108AN	Distributor	70522008	

## 2. Features and benefits

2

### Index

2.1	Benefits of the choice.....	9
2.1.1	Choice range.....	9
2.1.1.1	Wide range of outdoor units.....	9
2.1.1.2	System configuration.....	9
2.1.1.3	Range of accessories.....	11
2.1.3	Flexible system.....	12
2.1.3.1	SET FREE system: combination of different outdoor units.....	12
2.1.3.2	SYSTEM FREE system: combination of different indoor units.....	13
2.1.3.3	Unit management through the range of remote controls.....	13
2.1.4	Availability of the Hi-Tool Kit selection software.....	13
2.1.4.1	Assisted air conditioning installation design.....	13
2.1.4.2	Variable installation capacity.....	14
2.2	Installation benefits.....	15
2.2.1	Outdoor units.....	15
2.2.1.1	Main features of the installation.....	15
2.2.1.2	Compact design that makes it easier to install.....	17
2.2.1.3	Easy and flexible pipe installation.....	18
2.2.1.4	Flexibility to expand the installation.....	19
2.2.1.5	Flexibility to branch out the pipes.....	19
2.2.1.6	High number of connectable inside units.....	21
2.2.2	Optional parts.....	21
2.2.2.1	CH units.....	21
2.2.3	Easy and flexible communication between units.....	22
2.2.3.1	H-LINK II bus.....	22
2.3	Start-up benefits.....	29
2.3.1	Automatic start-up.....	29
2.3.1.1	Test run and identification of the system units.....	29
2.3.1.2	Test run from the remote control.....	29
2.3.1.3	Test run from the outdoor unit.....	30
2.3.2	Service verification.....	30
2.3.2.1	System operation control.....	30
2.3.2.2	Assisted-management air conditioning system.....	30
2.3.2.3	Compilation of operating data.....	30
2.3.3	Automatic system to estimate the amount of refrigerant charged in the unit.....	30
2.4	Functional benefits.....	32
2.4.1	General features.....	32
2.4.1.1	Greater efficiency.....	32
2.4.1.2	Reduced power consumption.....	32
2.4.2	Multiple capacity control.....	32
2.4.3	Individual management capacity with a minimum of 0.8 HP.....	32
2.4.4	Silent compressor.....	32
2.4.5	Silent fan.....	33

2.4.6	Highly efficient refrigerant cycle.....	33
2.4.7	DC Inverter Scroll Compressor.....	34
2.4.8	Low noise level for compressor.....	35
2.4.9	Efficiency.....	35
2.4.10	Inverter Control.....	35
2.4.11	Total reduced capacity for the outside unit.....	36
2.4.12	Wide range of operating possibilities.....	38
2.4.13	Night mode (optional function).....	38
2.4.14	Emergency (backup) function.....	39
2.4.15	Outdoor unit rotation function.....	40
2.4.16	Control over operating values (optional function).....	41
2.5	Maintenance benefits.....	42
2.5.1	Access cover for installation and maintenance.....	42
2.5.2	Availability of maintenance tools.....	42
2.5.2.1	HITACHI Service Tools.....	42
2.5.2.2	Monitoring the system and simplifying maintenance work.....	42
2.5.2.3	Decrease in operation costs.....	42
2.6	Simple maintenance.....	43
2.6.1	Optimised design to simplify maintenance.....	43
2.6.2	Minimum or zero maintenance.....	43
2.6.3	Loyal to the HITACHI philosophy.....	43











## 2.1 Benefits of the choice

### 2.1.1 Choice range

#### ◆ Wide range of outdoor units

The necessary space, structure and functions, in line with the evolution in terms of building design, mean that air conditioning requirements have also diversified.

The HITACHI SET FREE FSXN series offers six types of modular outdoor unit. By combining the units from a wide selection of models, a personalised air conditioned area can be created in line with the specific conditions of the building.

Base models	Capacity (HP)																								
	8	10	12	14	16	18	20	22	24	26	28	30	32	34	36	38	40	42	44	46	48	50	52	54	
	●	●	●																						
				●	●	●																			
Combination of models	Capacity (HP)																								
	8	10	12	14	16	18	20	22	24	26	28	30	32	34	36	38	40	42	44	46	48	50	52	54	
							●																		
								●	●	●															
											●	●	●	●	●										
																●	●	●							
																			●	●	●				
																						●	●	●	

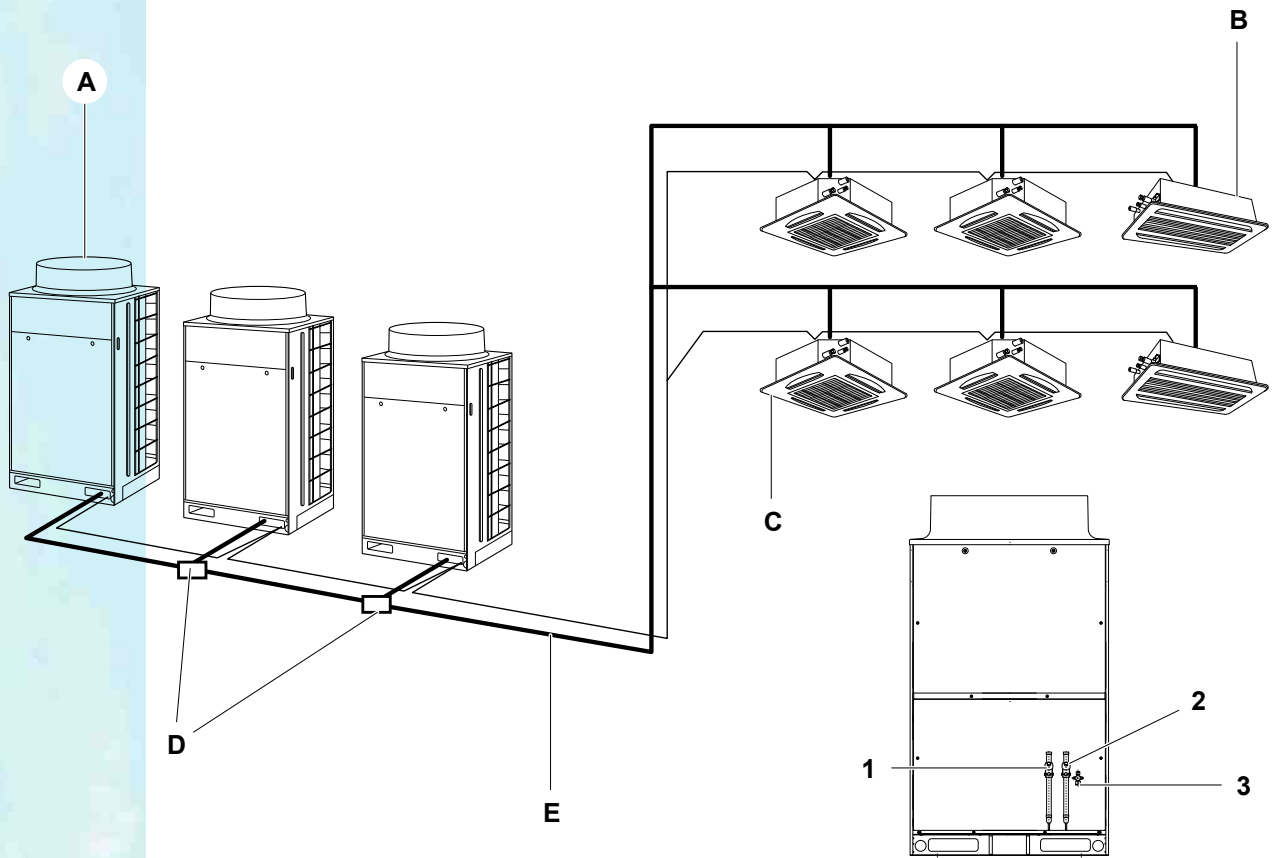
#### ◆ System configuration

Outdoor unit capacity is increased up to 54 HP through the use of an (8-18) HP unit or by combining two or a maximum of three (20-54) HP outdoor units.

This system can cool and heat separately (heat pump system, using two pipes) or it can provide simultaneous cooling and heating (heat recovery system, using three pipes).

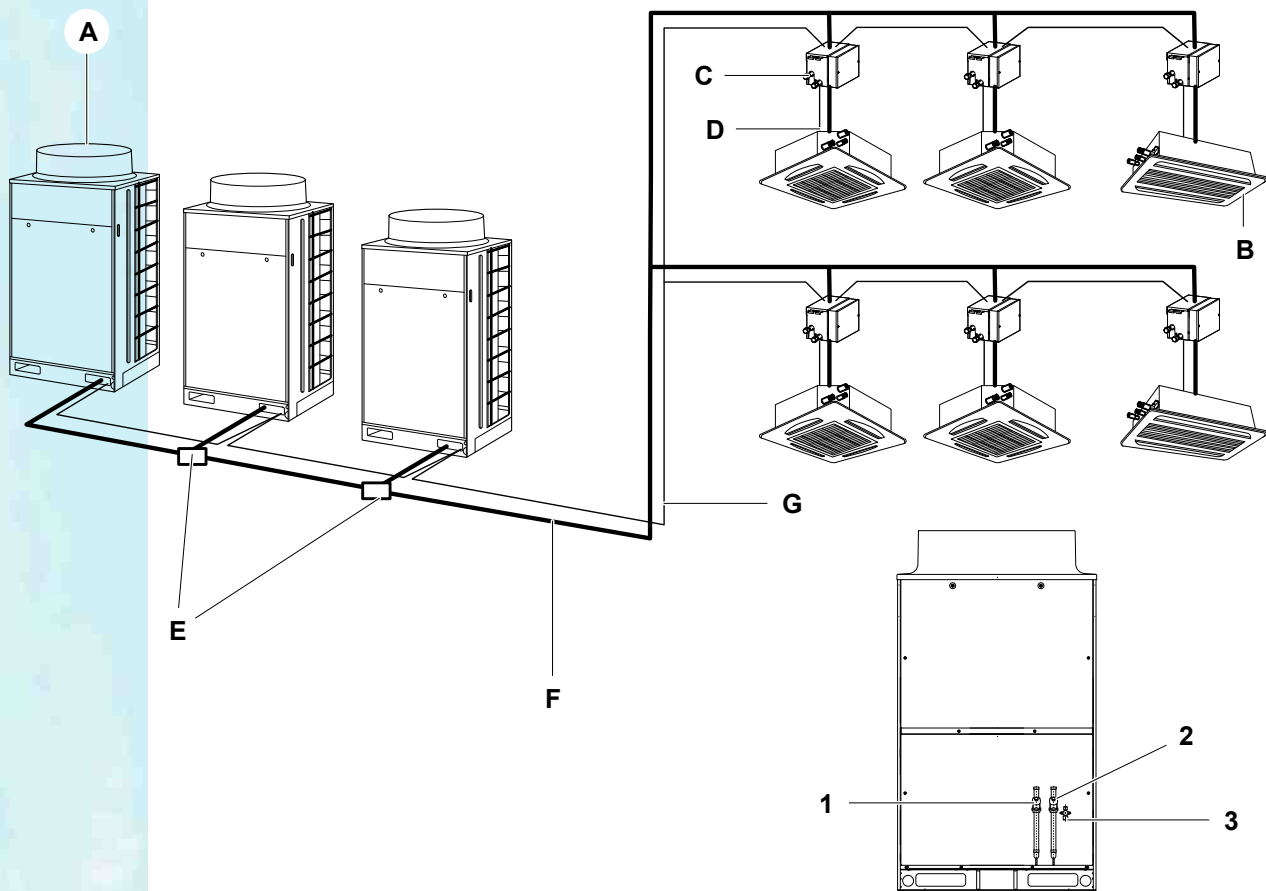


**Heat pump system**



A	Outdoor units
B	Indoor units
C	Control line (H LINK II)
D	Piping connection Kit
E	Refrigerant piping
1	Gas line ref. piping connection (low pressure)
2	Gas line ref. piping connection (high pressure)
3	Liquid line ref. piping connection

## Heat recovery system



2

A	Outdoor units
B	Indoor units
C	CH units
D	Refrigerant piping
E	Piping connection kit
F	Refrigerant piping
G	Control line (H LINK II)
1	Gas line ref. piping connection (low pressure)
2	Gas line ref. piping connection (high pressure)
3	Liquid line ref. piping connection

### ◆ Range of accessories

All outdoor units have a range of accessories for easier installation, operating and maintenance.

These accessories are designed to adapt the unit to the type of installation that the air conditioning system needs and to improve its performance, considering the quality parameters required.

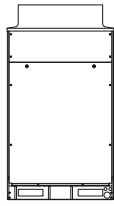
The range of accessories includes:

- Remote controls for the handling and management of the installation's operation.
- Branch pipes (piping connection kit and multikits), distributors and manifolds to effectively complete the installation.
- Drain pipes to collect and subsequently channel condensation.
- CH units (for heat recovery systems only).

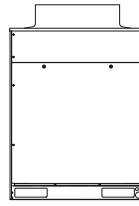
### 2.1.3 Flexible system

◆ **SET FREE system: combination of different outdoor units**

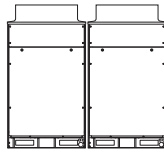
RAS-8 to 12FSXN (8 to 12HP)



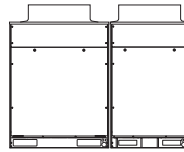
RAS-14 to 18FSXN (14 to 18HP)



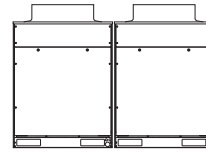
RAS-20FSXN (20HP)



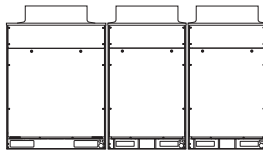
RAS-22 to 26FSXN (22 to 26HP)



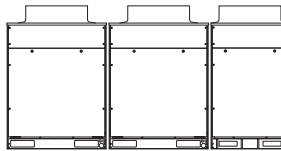
RAS-28 to 36FSXN (28 to 36HP)



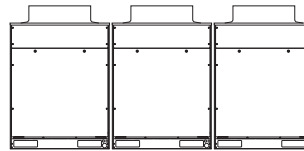
RAS-38 to 42FSXN (38 to 42HP)



RAS-44 to 48FSXN (44 to 48HP)



RAS-50 to 54FSXN (50 to 54HP)



The outdoor units of the SET FREE FSXN series can be combined as required to offer the best and most suitable features for all air conditioning requirements.

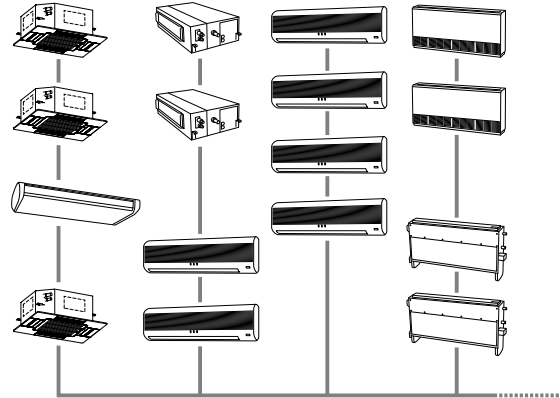
The variety of capacities that can be obtained from combining a small number of outdoor units (a maximum of three), known as base units, makes the precise design of installations much easier. At the same time, the stock of units stored is reduced, as it is possible to meet a wide range of requirements with the appropriate combination of few outdoor units.

Furthermore, unit management through any of the remote control systems available means that the total performance of the system is optimised.

#### ◆ **SYSTEM FREE system: combination of different indoor units**

The indoor units of the SYSTEM FREE series can be combined as required in any HITACHI system to create the most suitable air conditioning system for each area.

The variety of capacities and mounting accessories largely facilitate installation design. Furthermore, unit management through any of the remote control systems available means that the total performance of the system is optimised.



#### ◆ **Unit management through the range of remote controls**

As well as the normal functions available on remote controls, the HITACHI SET FREE FSXN range of outdoor units includes simultaneous management functions for groups of units.

- It is possible to use two remote controls for two indoor units or just one remote control, arranging the indoor units into control groups (from 1 to 16 units in each group).
- The built-in safety functions keep the timer running in the event of problems with the power supply (including power cuts lasting several weeks).
- Activation of the optional "night mode" function, which changes fan management on the outdoor units to reduce sound emission during the night in urban areas or especially sensitive areas like hospitals.
- Additional optional functions to groups of units such as simultaneous fan rotation.

Management functions also include the solving of any incidents that could arise.

- Automatic check for incident solving that provides real-time information through an alarm code.
- Incident codes displayed on the remote control screen where an operating problem arises. Detailed information is also displayed on these codes.

### 2.1.4 Availability of the Hi-Tool Kit selection software

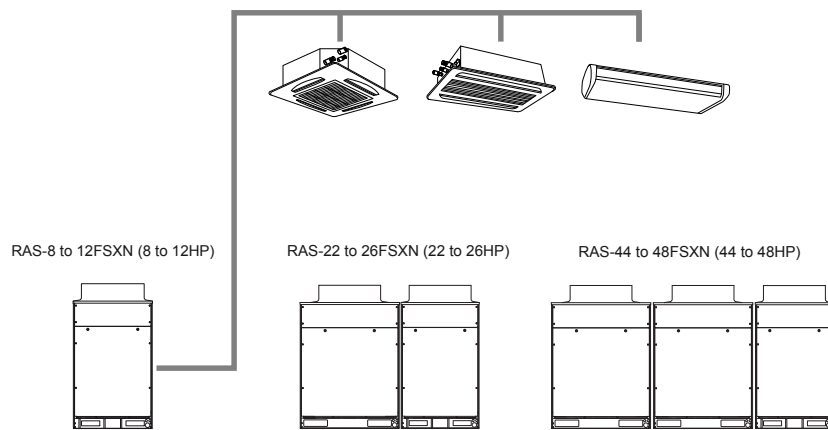
#### ◆ **Assisted air conditioning installation design**

The Hi-Tool Kit selection software is a tool for designing HVAC installations and automatically generating all necessary related information to complete the planned installation.

The necessary related information includes:

- Product selection table.
- Cooling and wiring diagram according to the installation design.
- Full list of necessary products to complete the installation.
- Installation start-up management.



◆ **Variable installation capacity**

Thanks to the extensive range of operating capacity control available in SET FREE FSXN systems, they can be adapted to the needs of each installation, in line with the power requirements in each situation.

Prior installations can be extended, bearing in mind that it is possible to install new indoor units to cover up to 130% of the capacity of the outdoor unit. In the opposite direction, installations can also be reduced to 50% of the capacity of the outdoor unit.

## 2.2 Installation benefits

### 2.2.1 Outdoor units

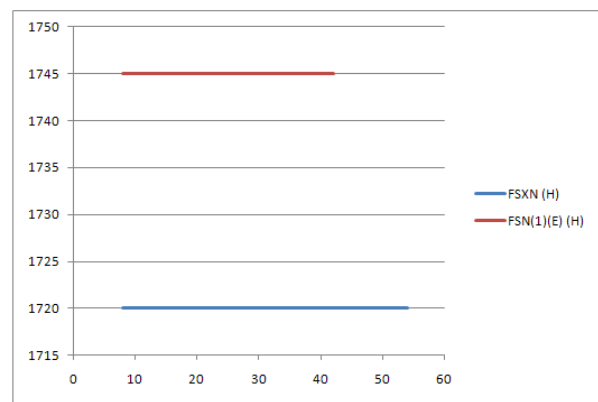
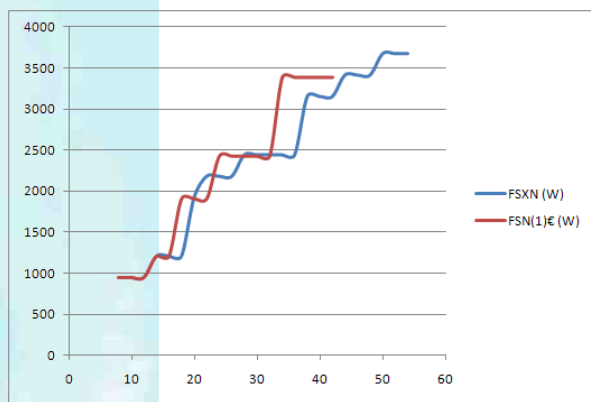
#### ◆ Main features of the installation

Size optimisation has also been taken into account in the design of FSXN units. As a result, they are more stylish than similar previous models.

Width x depth x height (kg)								
HP	(8-12)	(14-18)	20	(22-26)	(28-36)	(38-42)	(44-48)	(50-54)
FSXN	950 x 765 x 1720	1210 x 765 x 1720	1920 <sup>(1)</sup> x 765 x 1720	2180 <sup>(1)</sup> x 765 x 1720	2440 <sup>(1)</sup> x 765 x 1720	3150 <sup>(1)</sup> x 765 x 1720	3410 <sup>(1)</sup> x 765 x 1720	3670 <sup>(1)</sup> x 765 x 1720

<sup>(1)</sup> A space of 20 mm between units is considered.

Width x depth x height (kg)					
HP	(8-12)	(14/16)	(18-22)	(24-32)	(34-42)
FSN(1)(E)	950 x 750 x 1745	1210 x 750 x 1745	1910 x 750 x 1745	2430 x 750 x 1745	3390 x 750 x 1745



The weight of the units has also been limited to offer a lighter-weight unit (up to a 55% reduction compared to similar power models) for easier installation on floors or roofs of buildings and for easier transport and handling.



#### NOTE

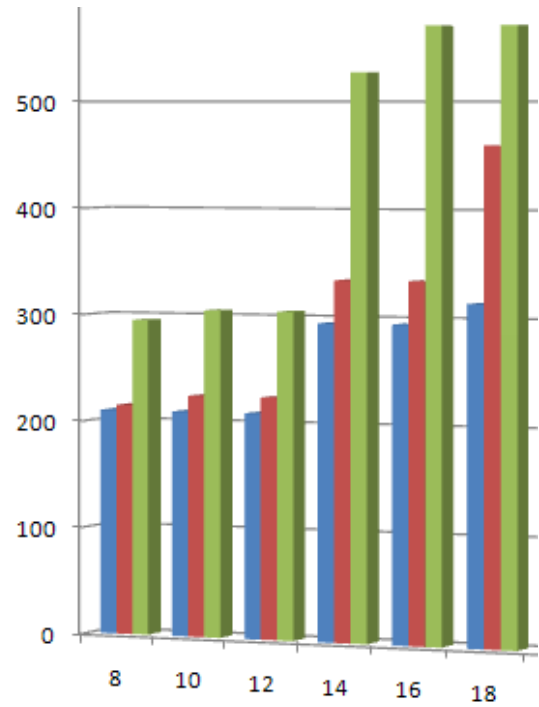
**Floors and roofs must be resistant enough to withstand the weight of the unit, bearing in mind the safety margins determined by the appropriate authorities in each country.**

HP	Weight (kg)			
	8	10,12	14, 16	18
FSXN	210	210	295	315
FSN(1)(E)	215	225	335	460
FXN(E)	295	305	527 <sup>(1)</sup>	570

<sup>(1)</sup> RAS-16FXN(E): 570 kg.

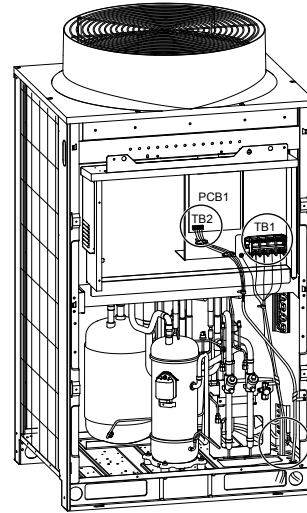
Smaller installation space is required, bearing in mind that both the width and the depth have been reduced. The distance between unit anchorage holes has been reduced by 31 mm and the width of the base of the unit by 29 mm. The supporting surface required is approximately 9% smaller compared with previous models.

FSXN outdoor units are fitted with a drain pipe as an optional accessory to turn the base of the unit into a condensate accumulation and drain pan. This accessory is particularly useful in climates with high atmospheric humidity to avoid the accumulation of water around the unit and the possible formation of filtrations in building roofs. This encourages the channelling of condensates to a drain-pipe in the building along an additional pipe supplied by the fitted.

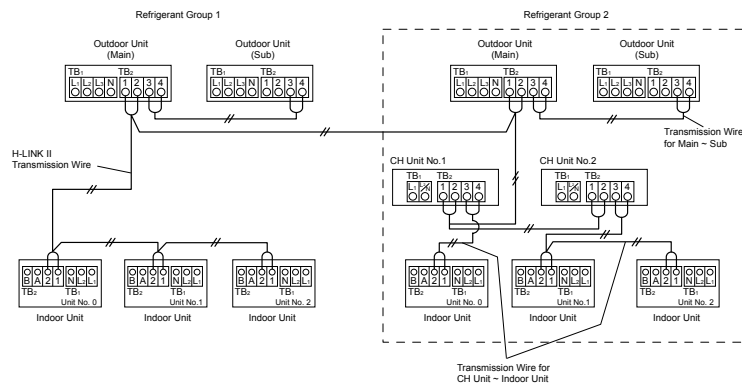




The electrical connection of the unit is centralised, i.e. all electricity and communications connections are made at a single point. Both electricity and communications cables enter the unit through their respective protective tubes and run to the electrical box for direct connection to the terminals on the circuit boards.



2



Units communicate via a two-core, non-polarity communications cable: communication faults due to connection errors during installation are avoided and the communication terminals are much smaller.

In the combination of two or up to three basic outdoor units with different power ranges to obtain superior power ranges, one of them must be the master or main unit. The remaining units in the combination (one or two), known as secondary units, act in coordination with the main unit. This is particularly useful to optimise the operating of them all, both together and individually. For example, in the event of a power cut to one of the units, the remainder take over its functions and control the supply capacity to minimise the drop in operating power.

For units installed in areas with adverse weather, particularly strong seasonal wind and/or snow, the outdoor units are fitted with guards that are supplied as an optional accessory. These guards are particularly useful in preventing a drop in output of the unit or its complete stoppage due to the blockage of its air inlets and outlets.



#### NOTE

**Outdoor units in areas with heavy snowfall must be installed on suitable foundations to ensure they remain at least 50 cm above maximum snowfall levels.**

◆ **Compact design that makes it easier to install**

The compact design of the SET FREE FSXN units makes them easier to handle and install. Their reduced volume means they take up less space in the building infrastructures until they are installed in their final location.

The lighter final weight of the units, including the more powerful ones, makes them easier to handle when positioning them in their final location.

Example: transport of the outdoor unit on a lift for 11 people, with a minimum opening of 800 mm and a depth of 1,350 mm (according to standard JIS A 4301).



### ◆ Easy and flexible pipe installation

#### Installation work optimisation

The HITACHI installation system is one of the most flexible and easiest to install in the market, offering substantial cost savings right from installation and start-up and throughout its working life, including any maintenance tasks.

The different members of the group of SET FREE outdoor units have the same installation parts, which makes them easier to assemble and leads to less material requirements.

#### Reduction and standardising of installation pipe diameters

The diameters of the necessary connection pipes have been standardised wherever possible during the design process for the SET FREE units. Therefore, most outdoor units use connection pipes of similar dimensions for the entire installation, thus making installation work easier.

It is possible to configure the entire installation of an air conditioning system using very few different pipe diameters.

#### Longer pipes between outdoor and indoor units

The distance between units is no longer a conditioning factor and has become a factor that favours freedom of design in air conditioning installations. The design and the power of the outdoor units mean that indoor units can be installed further away.

The possibility of installing outdoor units further away offers greater decision-making autonomy and means that the most favourable location can be chosen. Depending on the model, the distance between outdoor and indoor units may be up to 1,000 metres.



#### NOTE

*When the total length of the refrigerant pipes exceeds 300 m, the maximum additional refrigerant charge must be extended. Check conditions in Chapter [#unique\\_29](#), see on page 0 .*

#### Multikits and distributors

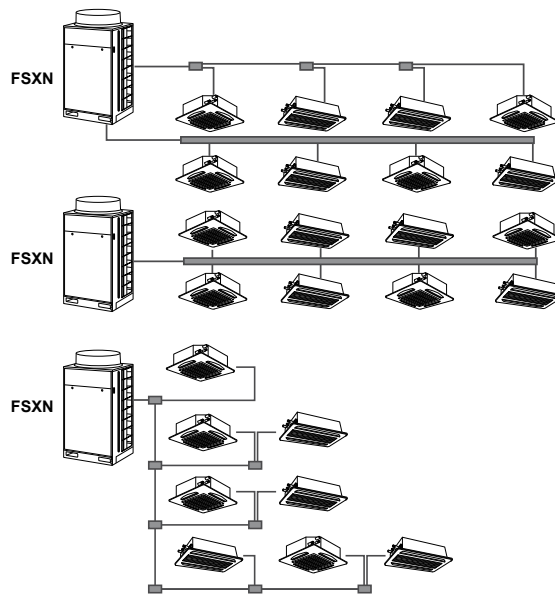
HITACHI SET FREE FSXN outdoor units offer great flexibility for the installation of outdoor and indoor units and for their interconnection, accepting different types of systems and up to a maximum of 64 indoor units for every outdoor unit.



#### NOTE

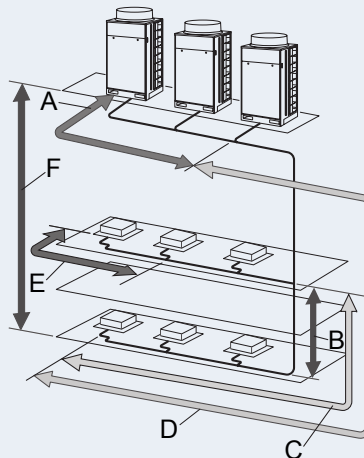
*For further details on the connection options and capacities of the outdoor units, see Chapter [Selection guide](#), see on page 62.*

The following figures show some examples of the many configuration possibilities for interconnection between outdoor and indoor units.



#### ◆ Flexibility to expand the installation

The installation can reach of maximum total refrigerant pipe length of 1,000 m. If required, the maximum length of pipe between the first multikit branch and the last connected indoor unit can reach up to 90 m. These values allow for an air conditioning installation design with fewer restrictions with regard to pipe length, which is more simplified and effective.



- A. Outdoor units.
- B. Difference in height of the indoor units.
- C. Maximum pipe length between the first multikit branch and the last connected indoor unit: 90 m.
- D. Length of pipe between outdoor and indoor units. Maximum total pipe length: 1000 m.
- E. Maximum pipe length between the branch and the indoor unit: 40 m.
- F. Difference in height between the outdoor unit and the indoor units.



#### NOTE

For further details and specific installation conditions, see Chapter #unique\_29, see on page 0 .

#### ◆ Flexibility to branch out the pipes

The flexible design for the air conditioning installations is one of the most important factors for the SET FREE FSXN

System. There is no limitation with regard to the number of installable multikits. Therefore, the refrigerant pipe lengths should be between the following values:

- Pipe length between the first multikit and the indoor unit:  $\leq 40$  m.
- Total length between the multikit and each one of the connected indoor units:  $\leq 30$  m.

Where the pipe length from the first multikit to each indoor unit is greater than 40 m, the number of branches should be increased.

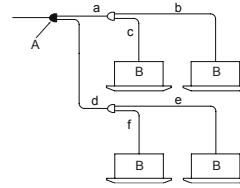
Maximum pipe length between the multikit of the first branch and each indoor unit	Pipe length after the branch	Number of main pipe branches
$\leq 40$ m	$a+b+c \leq 30$ m or $d+e+f \leq 30$ m	No limit
	$a+b+c > 30$ m or $d+e+f > 30$ m	Up to 2
From 41 m to 90 m	—	Up to 1


**NOTE**

<sup>(1)</sup> **Main pipe branch: distribution from one (1) multikit to two (2) multikits.**

A: main branch.

B: indoor units.



◆ **High number of connectable inside units**

To adapt to all connection needs and possibilities as fully as possible, the maximum number of connectable indoor units for a single SET FREE FSXN

outdoor unit is 64. Compared with previous models, this characteristic represents a huge advantage, as it is possible to manage a greater number of indoor units with less outdoor units, which means significant energy and installation savings.

Models	HP	5	8	10	12	14	16	18	20	22	24	26	28	30
Previous models	Maximum number of connectable indoor units, FSN(1)(E) model	8	13	16	16	20	20	20	20	20	27	29	31	32
	Maximum number of connectable indoor units, FXN model	—	13	16	16	—	20	20	20	20	27	29	—	32
FSXN Model	Maximum number of connectable indoor units	—	13	16	19	23	26	26	33	36	40	43	47	50
	Recommended number of connectable indoor units	—	8	10	10	16	16	16	18	20	26	26	32	32

Models	HP	32	34	36	38	40	42	44	46	48	50	52	54
Previous models	Maximum number of connectable indoor units, FSN(1)(E) model	32	32	32	32	32	32	—	—	—	—	—	—
	Maximum number of connectable indoor units, FXN model	32	—	—	—	—	—	—	—	—	—	—	—
FSXN Model	Maximum number of connectable indoor units	53	56	59	64	64	64	64	64	64	64	64	64
	Recommended number of connectable indoor units	32	32	32	38	38	38	38	38	38	38	38	38

**i** **NOTE**

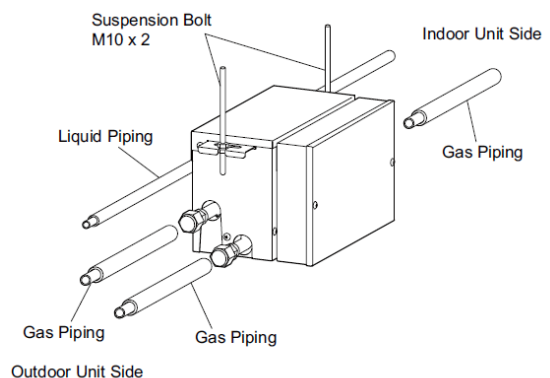
For further details on connection options and capacities of outdoor unit, see Chapter #unique\_35, see on page 0 .

**2.2.2 Optional parts**

◆ **CH units**

HITACHI carries units CH-6.0N1 y CH-10.0N1 as optional elements for heat recovery systems (3 pipes). In these systems, the CH units allow the indoor units connected to them to operate in cooling or heating mode, regardless of the operating mode for other indoor units connected to other CH units.

The installation of these units facilitates the creation of sectors within the air conditioning system that operate in an independent cooling or heating mode, whereby reducing the amount of pipes needed and the complexity of the installation.



The electrical box for the CH unit has a flexible attachment system that enables it to be installed in either of its two sides so that it adapts to the available installation spaces.



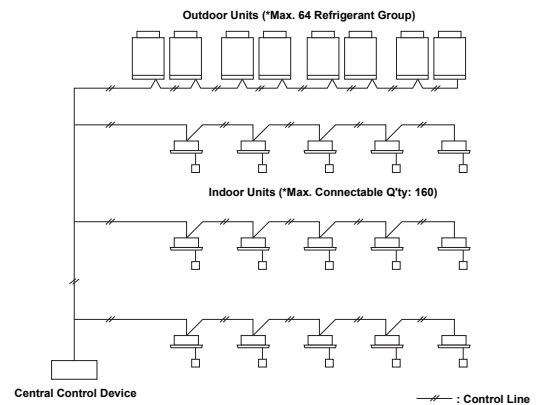
#### NOTE

- *The CH unit makes a small amount of noise, especially during start-up or when the indoor unit stops or when the defrost mode on the outdoor unit is activated in very low outdoor temperatures.*
- *The CH unit can be installed in a false ceiling for example, or in separate area from the indoor unit. The unit is supplied in kit form, with the necessary connections for the refrigerant pipes.*

### 2.2.3 Easy and flexible communication between units

#### ◆ H-LINK II bus

The outdoor units belonging to the SET FREE FSXN series are fitted with the H-LINK II communications (bus). 64 refrigeration cy-



cles and a maximum of 160 indoor units can be controlled using just one centralised control system through the H-LINK II bus.


**NOTE**

*The control system, the indoor units and the remote control must be compatible with the H-LINK II bus.*

**Comparison of the H-LINK system with the H-LINK II system**

Element	H-LINK	H-LINK II
Maximum number of manageable refrigeration groups	16	64
Direction setting range for refrigeration groups and indoor units	0 to 15	0 to 63
Maximum number of indoor units / systems	128	160
Total number of centralised control systems in the same H-LINK bus	145	200
Maximum wiring length	1000 m <sup>(1)</sup>	

2


**NOTE**

*<sup>(1)</sup> Up to 5000 m using the accessories available*

### Combination of the H-LINK system and the H-LINK II system

The indoor and outdoor units fitted with the H-LINK communications bus system can be combined with units fitted with the H-LINK II bus system without the need for adapters.

Communications bus	Outdoor unit Indoor unit	One (1) H-LINK (II) communications bus system	
		Outdoor units (number of refrigeration groups)	Indoor units
H-LINK	H-LINK II	64	160
	H-LINK and H-LINK II combination	64 <sup>(1)</sup>	128
H-LINK II	H-LINK II	16	128
	H-LINK and H-LINK II combination	16	128



#### NOTE

<sup>(1)</sup> Up to a maximum of 16 refrigeration groups available in one (1) H-LINK communications bus system under the following conditions:

- H-LINK outdoor unit.
- H-LINK II outdoor unit connected to H-LINK indoor units.

Over 17 indoor units can be connected to one (1) outdoor unit, depending on its capacity. In this case, two (2) refrigeration groups are required for one (1) outdoor unit.

System configuration	Outdoor unit: H-LINK Indoor unit: H-LINK and H-LINK II Remote control: H-LINK and H-LINK II			Outdoor unit: H-LINK II Indoor unit: H-LINK and H-LINK II Remote control: H-LINK and H-LINK II		
	Layout					
Refrigeration group setting <sup>(1)</sup>	0 to 15			0 to 15		
Direction setting range <sup>(1)</sup>	0 to 15	0 to 15	0 to 15	0 to 15	0 to 15	0 to 15
Automatic temperature setting reset <sup>(2)</sup>	No	Yes	Yes	No	Yes	Yes
Operation lock <sup>(2)</sup>	No	Yes	Yes	No	Yes	Yes
Temperature setting range limitation <sup>(3)</sup>	No	Yes	Yes	No	Yes	Yes
ON/OFF timer setting (72 h) <sup>(2)</sup>	No	Yes	Yes	No	Yes	Yes
Different operating mode indication <sup>(3)</sup>	No	No	Yes	No	No	Yes
Indoor unit hot start indication <sup>(3)</sup>	No	No	Yes	No	No	Yes
Refrigeration group and direction change on indoor unit <sup>(2)</sup>	No	No	Yes	No	No	Yes
Pre-heating / cancellation indication on outdoor unit <sup>(2)</sup>	No	No	No	No	No	Yes
Emergency mode from remote control <sup>(4)</sup>	No	No	No	No	No	Yes

<sup>(1)</sup> The direction setting range for refrigeration groups and indoor units is from 0 to 15 when a central H-LINK control is used.

<sup>(2)</sup> This function can only be set using the PC-ART remote control.

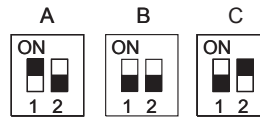
<sup>(3)</sup> This function can only be set using the PC-ART remote control and the PC-ARH control.

<sup>(4)</sup> Depending on the outdoor unit, this function is not available.

#### Cancellation of final resistance



Prior to supply, DSW10 contact 1 is set to ON. Where two or more outdoor units are installed and connected using the H-LINK bus, DSW10 contact 1 on the master or main unit must be set to OFF from the second unit.



Where just one unit is installed, this setting is not required.

- A: setting before supply:
- B: cancellation of final resistance.


**NOTE**

- **C: If the communication circuit fuse has opened, the PCB1 board can only be recovered by activating contact 2.**

**2**
**Reciprocity of outdoor units for H-LINK II**

Outdoor unit, SET FREE series						
FSN models			FSXN models			FSNM models
RAS-8FSN2	RAS-24FSN2	RAS-40FSN2	RAS-8FSXN	RAS-24FSXN	RAS-40FSXN	RAS-8FSNM
RAS-10FSN2	RAS-26FSN2	RAS-42FSN2	RAS-10FSXN	RAS-26FSXN	RAS-42FSXN	RAS-10FSNM
RAS-12FSN2	RAS-28FSN2	RAS-44FSN2	RAS-12FSXN	RAS-28FSXN	RAS-44FSXN	RAS-12FSNM
RAS-14FSN2	RAS-30FSN2	RAS-46FSN2	RAS-14FSXN	RAS-30FSXN	RAS-46FSXN	—
RAS-16FSN2	RAS-32FSN2	RAS-48FSN2	RAS-16FSXN	RAS-32FSXN	RAS-48FSXN	—
RAS-18FSN2	RAS-34FSN2	—	RAS-18FSXN	RAS-34FSXN	RAS-50FSXN	—
RAS-20FSN2	RAS-36FSN2	—	RAS-20FSXN	RAS-36FSXN	RAS-52FSXN	—
RAS-22FSN2	RAS-38FSN2	—	RAS-22FSXN	RAS-38FSXN	RAS-54FSXN	—

Outdoor unit, UTOPIA DC INVERTER series		
IVX models	ES models	DC INVERTER models
RAS-8HRNM	RAS-3HVRNS	RAS-2HVRN1
RAS-10HRNM	RAS-4HVRNS(1)E	RAS-2.5HVRN1
RAS-12HRNM	RAS-5HVRNS(1)E	—
RAS-3HVRNME	RAS-6HVRNS(1)E	—
RAS-4H(V)RNM(1)E	—	—
RAS-5H(V)RNM(1)E	—	—
RAS-6H(V)RNM(1)E	—	—

**Reciprocity of indoor units for H-LINK II**

FSN2(E) indoor units								
RCI	RCIM	RCD	RPC	RPI	RPIM	RPK	RPF	RPMI
4-way cas- sette	4-way cas- sette (com- pact)	2-way cas- sette	Ceiling type	Ducted indoor unit	Ducted indoor unit (compact)	Wall type	Floor type	Floor con- cealed type
RCI-1.0 FSN2E	RCIM-1.0 FSN2	RCD-1.0 FSN2	RPC-2.0 FSN2E	RPI-0.8 FSN2E	RPIM-0.8 FSN2E	RPK-1.0 FSN2M	RPF-1.0 FSN2E	RPMI-1.0 FSN2E
RCI-1.5 FSN2E	RCIM-1.5 FSN2	RCD-1.5 FSN2	RPC-2.5 FSN2E	RPI-1.0 FSN2E	RPIM-0.8 FSN2E(-DU)	RPK-1.0 FSNH2M	RPF-1.5 FSN2E	RPMI-1.5 FSN2E
RCI-2.0 FSN2E	RCIM-2.0 FSN2	RCD-2.0 FSN2	RPC-3.0 FSN2E	RPI-1.5 FSN2E	RPIM-1.0 FSN2E	RPK-1.5 FSN2M	RPF-2.0 FSN2E	RPMI-2.0 FSN2E
RCI-2.5 FSN2E	—	RCD-2.5 FSN2	RPC-4.0 FSN2E	RPI-2.0 FSN2E	RPIM-1.0 FSN2E(-DU)	RPK-1.5 FSNH2M	RPF-2.5 FSN2E	RPMI-2.5 FSN2E
RCI-3.0 FSN2E	—	RCD-3.0 FSN2	RPC-5.0 FSN2E	RPI-2.5 FSN2E	RPIM-1.5 FSN2E	RPK-2.0 FSN2M	—	—
RCI-4.0 FSN2E	—	RCD-4.0 FSN2	RPC-6.0 FSN2E	RPI-3.0 FSN2E	RPIM-1.5 FSN2E(-DU)	RPK-2.5 FSN2M	—	—
RCI-5.0 FSN2E	—	RCD-5.0 FSN2	—	RPI-4.0 FSN2E	—	RPK-3.0 FSN2M	—	—
RCI-6.0 FSN2E	—	—	—	RPI-5.0 FSN2E	—	RPK-4.0 FSN2M	—	—
—	—	—	—	RPI-6.0 FSN2E	—	—	—	—
—	—	—	—	RPI-8.0 FSN2E	—	—	—	—
—	—	—	—	RPI-10.0 FSN2E	—	—	—	—

**Reciprocity of outdoor units for H-LINK**

Outdoor unit, SET FREE series				
FSN(E) models		FXN models	FSVNE models	HVRNE DC INVERTER models
RAS-5FSN	RAS-26FSN(1)	RAS-8FXN(E)	RAS-3FSVNE	RAS-3HVRNE
RAS-8FSN(1)(E)	RAS-28FSN(1)	RAS-10FXN(E)	RAS-4FSVNE	RAS-4H(V)RNE
RAS-10FSN(1)(E)	RAS-30FSN(1)	RAS-12FXNE	RAS-5FSVNE	RAS-5H(V)RNE
RAS-12FSN(1)(E)	RAS-32FSN(1)	RAS-16FXN	—	RAS-6H(V)RNE
RAS-14FSN(1)	RAS-34FSN	RAS-18FXN	—	—
RAS-16FSN(1)	RAS-36FSN	RAS-20FXN	—	—
RAS-18FSN(1)	RAS-38FSN	RAS-22FXN	—	—
RAS-20FSN(1)	RAS-40FSN	RAS-24FXN	—	—
RAS-22FSN(1)	RAS-42FSN	RAS-26FXN	—	—
RAS-24FSN(1)	—	RAS-30FXN	—	—
—	—	RAS-32FXN	—	—

## Reciprocity of indoor units for H-LINK

FSN2(E) indoor units								
RCI	RCIM	RCD	RPC	RPI	RPIM	RPK	RPF	RPFI
4-way cas- sette	4-way cas- sette (com- pact)	2-way cas- sette	Ceiling type	Ducted indoor unit	Ducted indoor unit (compact)	Wall type	Floor type	Floor con- cealed type
RCI-1.0 FSN(1)E	RCIM-1.0 FSN	RCD-1.0 FSN	RPC-2.0 FSNE	RPI-0.8 FSN(1)E	RPIM-0.8 FSN1E	RPK-0.8 FSN1M	RPF-1.0 FSNE	RPFI-1.0 FSNE
RCI-1.5 FSN(1)E	RCIM-1.5 FSN	RCD-1.5 FSN	RPC-2.5 FSNE	RPI-1.0 FSN(1)E	RPIM-1.0 FSN1E	RPK-1.0 FSN1M	RPF-1.5 FSNE	RPFI-1.5 FSNE
RCI-2.0 FSN(1)E	RCIM-2.0 FSN	RCD-2.0 FSN	RPC-3.0 FSNE	RPI-1.5 FSN(1)E	—	RPK-1.5 FSN1M	RPF-2.0 FSNE	RPFI-2.0 FSNE
RCI-2.5 FSN(1)E	—	RCD-2.5 FSN	RPC-4.0 FSNE	RPI-2.0 FSN(1)E	—	RPK-2.0 FSN1M	RPF-2.5 FSNE	RPFI-2.5 FSNE
RCI-3.0 FSN(1)E	—	RCD-3.0 FSN	RPC-5.0 FSNE	RPI-2.5 FSN(1)E	—	RPK-2.5 FSN1M	—	—
RCI-4.0 FSN(1)E	—	RCD-4.0 FSN	RPC-6.0 FSNE	RPI-3.0 FSN(1)E	—	RPK-3.0 FSN1M	—	—
RCI-5.0 FSN(1)E	—	RCD-5.0 FSN	—	RPI-4.0 FSN(1)E	—	RPK-4.0 FSN1M	—	—
RCI-6.0 FSN(1)E	—	—	—	RPI-5.0 FSN(1)E	—	—	—	—
—	—	—	—	RPI-6.0 FSN(1)E	—	—	—	—

### Complete communication

The indoor units maintain active communications with each other, with the outdoor units and with the control systems over a communication line (bus) called H-LINK II. This way the performance of each unit, among other aspects, is adapted to the circumstances at all times and remains the most appropriate in each situation.

### Easy connection

The communications bus is formed by a pair of small-diameter cores with no specific polarity. Given that no multi-way communication cables are used, the installation is simple, fast and effective. It is impossible to confuse the connections.

The two-core non-polarity communication bus provides significant savings in terms of materials and installation, as the same cable is used for all the units and is quickly and simply connected directly to them.

### Long distance

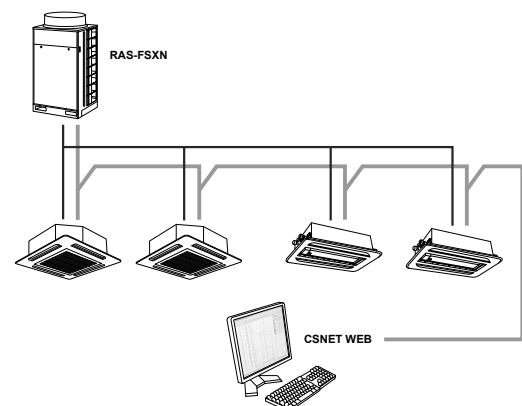
The total length of the communications bus line between all the units can reach 1,000 m. Where the communications line must be longer (e.g. to expand the HVAC system or to manage the units from a unified station in the building), the total distance can be extended to 5,000 m by using the accessories available.

### Up to 160 units connected in a single H-LINK II bus line

It is possible to connect up to 160 indoor units from the SYSTEM FREE range in a single H-LINK II bus line. To expand the installation or increase the bus lines available, simply add a new line.

All of the units are managed as one through the control systems installed.

Example of H-LINK II system:



**Specifications:**

Transmission cable:	2 conductors
Transmission cable polarity:	No polarity
Maximum number of outdoor units connected:	64 units per H-LINK II system
Maximum number of indoor units connected:	160 units per H-LINK II system
Maximum number of units:	200
Maximum wiring length:	Total 1,000 m (including CSNET-WEB)
Recommended cable:	Shielded twisted pair cable or shielded pair cable over 0.75 mm <sup>2</sup> (equivalent to KPEV-S)
Voltage:	5 V DC


**NOTE**

- *The DIP switches must be adjusted when the H-LINK II bus is used. Otherwise, or if these are incorrectly adjusted, a transmission incident could occur.*
- *The H-LINK II system offers great flexibility for the design of air conditioning systems, as installation is simple and the total cost affordable. Furthermore, centralised management is possible by connecting the CSNET-WEB control system to the H-LINK II network cables.*
- *Additionally, using CSNET-WEB, it is possible to manage the installation over the internet.*

**Fast connection of new units**

Extending the air conditioning system is now even easier. To add new units to the communications bus, simply connect its two cables to the communications terminals.

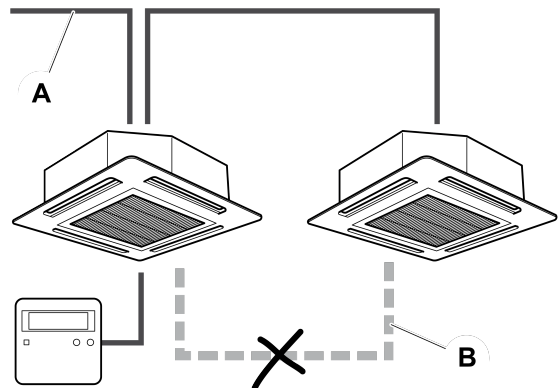
The new units that are added to the bus line are recognised by the control system and are automatically configured.

**No operating cable for the remote control**

In the case of systems with outdoor units connected to twin, triple or quadruple indoor unit systems, both the indoor and the outdoor units can be controlled by a single remote control, without having to be connected together using a specific control cable.

A: service cable.

B: specific cable for operating the remote control unnecessary.


**Auto-configuration of system units**

The air conditioning system control systems are auto-configuring. They recognise the type of unit they are connected to, along with the type of indoor unit and its capacity. Installation start-up is quick and efficient.

All the equipment can also be manually configured, in order to set the installation according to personalised parameters.

## 2.3 Start-up benefits

### 2.3.1 Automatic start-up

The installation is started up automatically, therefore considerably reducing the time required for the process.

There are three types of start-up:

- Test run and identification of the units forming the system.
- Test run from the remote control.
- Test run from the outdoor unit.

#### ◆ Test run and identification of the system units

The test run can be carried out from either the rotating DIP switches on the outdoor unit or from the remote control for the indoor unit.

The seven-segment indicator on the outdoor unit provides all of the information required to check the system is operating properly.

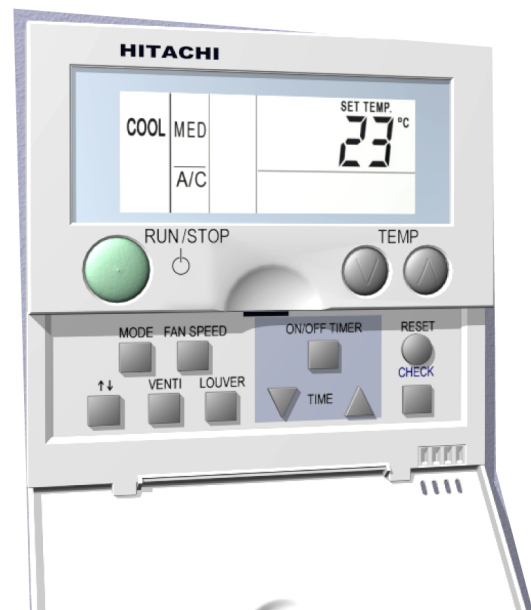
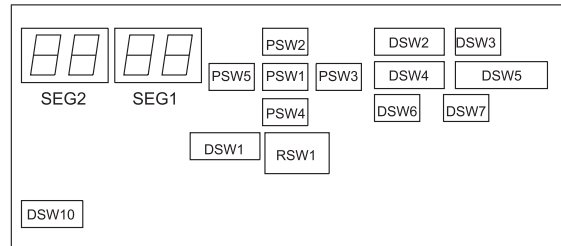
The units forming part of the system are identified separately for the outdoor and indoor units:

- Outdoor units: the remote control can be used to allocate the series to which the operational outdoor units belong (e.g. single or multiple series).
- Indoor units: using the rotating DIP switch on each unit.

#### ◆ Test run from the remote control

Three operations for the test run are possible from the remote control:

- 1 Auto-diagnostic: quick check of the operating conditions of the indoor units and outdoor unit.
- 2 Data memory query: in the event of an alarm, the remote control saves all the operating parameters of the unit at that particular time and the screen displays the corresponding fault code. The air conditioning system diagnostic is simple and effective.
- 3 Setting optional functions: the remote control is able to make settings on up to 29 possible options, such as the four-degree offset in heating mode or the increase in fan speed. It is possible



to set several indoor units at the same time and to modify the unit configuration once installation is complete.

#### ◆ Test run from the outdoor unit

The seven-segment indicator on the outdoor unit displays parameters relating to its working order. Any incident arising during start-up or normal operation can be diagnosed from the indicator.

### 2.3.2 Service verification

#### ◆ System operation control

The working order of the system is continuously monitored through the control system. All operating parameters that the system uses to manage the outdoor and indoor units are continuously supervised.

#### ◆ Assisted-management air conditioning system

La gestión del sistema de climatización puede realizarse cómodamente mediante el software de gestión asistida HITACHI Service Tools.

Este software permite la conexión de, por ejemplo, un ordenador portátil al sistema de climatización a través de una interfaz conectada al bus H-LINK II. A través de diferentes menús, el software permite gestionar todos los sistemas conectados de forma eficaz y obtener datos para optimizar el rendimiento del sistema.



#### ◆ Compilation of operating data

Todos los datos obtenidos mediante el software HITACHI Service Tools son recopilados en diferentes formatos y monitorizados de varias formas. El usuario del software puede configurar el manejo de los datos para monitorizar aquellos parámetros que resultan más interesantes en cada instalación.

Los informes de datos permiten verificar el funcionamiento del sistema de forma continuada. Cualquier desviación en los rangos de valores previstos se detecta de inmediato.

### 2.3.3 Automatic system to estimate the amount of refrigerant charged in the unit

The system that automatically estimates the amount of refrigerant charged in the unit is responsible for checking whether the amount of available refrigerant is enough for the entire system to operate properly in the assigned refrigeration cycle.

The system performs a series of calculations to estimate the amount of refrigerant needed to cover the requirements indicated through remote control. It takes into account the following variables:

- Refrigerant cycle temperature.
- Refrigeration saturation temperature.
- Data from the expansion valve on the outdoor unit.
- Data from the indoor units.

Connect the power supply for the indoor and outdoor units from the same refrigeration cycle to make this verification. Now put DSW5 (in PCB1) contact number four in the ON position and press PSW1.

It takes between 30 and 40 minutes to perform the required verifications. During the test, the refrigeration mode activates automatically and the remote control screen display the indication TEST RUN.

The results of the test are shown on the seven-segment display for the PCB1:

Display indication	Result	Indications
	Sufficient charge	The refrigerant charge is sufficient.
	Excessive charge	The refrigerant charge is excessive. Calculate the refrigerant charge according to the length of the refrigerant pipes. Collect the charged refrigerant appropriately and charge the unit with correct amount of refrigerant.
	Insufficient charge	The refrigerant charge is insufficient. Check whether the unit has been charged with additional refrigerant. Calculate the refrigerant charge according to the length of the refrigerant pipes. Charge the unit with correct amount of refrigerant.

2



### CAUTION

- *Leaks can be one of the causes of insufficient refrigerant charge.*
- *An excessive or insufficient refrigerant charge can shorten the life of the outdoor unit, cause frequent incident alarms or insufficient capacity.*

## 2.4 Functional benefits

### 2.4.1 General features

#### ◆ Greater efficiency

The outdoor units of the SET FREE FSXN range have a high level of energy efficiency thanks to their low energy demand, a key value to be considered during the design stage of any HVAC system and the putting into practice of measures to reduce energy demand.

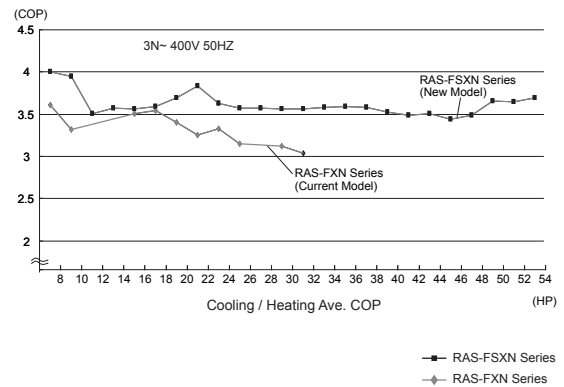
Therefore, the efficiency of the HITACHI range of units favours the saving of energy and costs.

#### ◆ Reduced power consumption

The SET FREE range of indoor units benefits from in-depth functional and construction studies on all of their parts, aimed at optimising and reducing power consumption. The harmonisation of all the internal components enables more rational operating modes, in accordance with current environmental demands.

The image shows an example that compares the COP for the RAS-(8-54)FSXN -A- models with a power supply of 380-415 V / 50 Hz to similar models from the FXN -B- series.

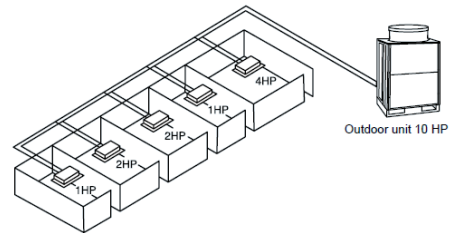
They achieved high yield and very efficient operations that, in consequence, ensure a significant reduction in the yearly cost of the electricity bill.



### 2.4.2 Multiple capacity control

In order for the air conditioning system to work more efficiently, the appropriate refrigerant flow volume is constantly controlled according to the number of indoor units that are running.

The most appropriate opening for the electronic expansion valve for refrigerant supply is controlled by the difference in air temperature between input and output on the indoor unit; all the units can operate in different conditions.



### 2.4.3 Individual management capacity with a minimum of 0.8 HP

The electronic expansion valves installed, both on the indoor and outdoor units enable precise control over refrigerant flow. This controlled precision enables indoor units to be connected with power levels starting from 0.8 HP up to 10.0 HP.

### 2.4.4 Silent compressor



The outdoor SET FREE FSXN units have been designed to reduce noise emissions as much as possible. The combined use of Scroll compressors and an insulation cover, reduces noise emissions to minimal levels.

The neodymium magnets on the compressor rotor (direct current) improve its features at low frequencies. Separating the compressor rotor into two parts reduces electromagnetic interference significantly.



2

### 2.4.5 Silent fan

#### Less operating noise with new designs and materials

The shape of the blades has been designed to minimise turbulence caused by the air forced through the fan. Furthermore, using mica and polypropylene to manufacture the fan minimises its typical vibrations and therefore lowers noise emissions. The laminated surface prevents the air from forming turbulence. This combination of materials and design improves noise emission in comparison with previous models.

#### Quiet operation with a silent motor

To prevent electromagnetic noise, a research process was performed on the materials used to manufacture the motor parts. As a result, cast aluminium and a low noise emission operating control system were chosen, without having to forfeit any operational features. Furthermore, a non-resonant suspension system has been incorporated into the fan motor. Vibrations are minimised thanks to this structure.

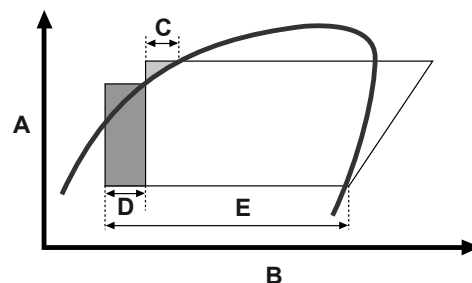
#### Low noise levels during nightly operation

Operating noise has been fully analysed through a computerised simulation of fluid turbulences, which are the main source of undesired noise, and by visual observation of these flows.

Operating noise has been further reduced by improving the structure of the cabinet and the shape of the fan and incorporating an inverter and other new materials. The result has been a quiet operating design that respects the people around it and the environment.

### 2.4.6 Highly efficient refrigerant cycle

The features on the outdoor unit have improved considerably by applying a super-cooling circuit for the refrigerant cycle and by optimising the piping system.



A	Pressure
B	Capacity
C	Effect of subcooler

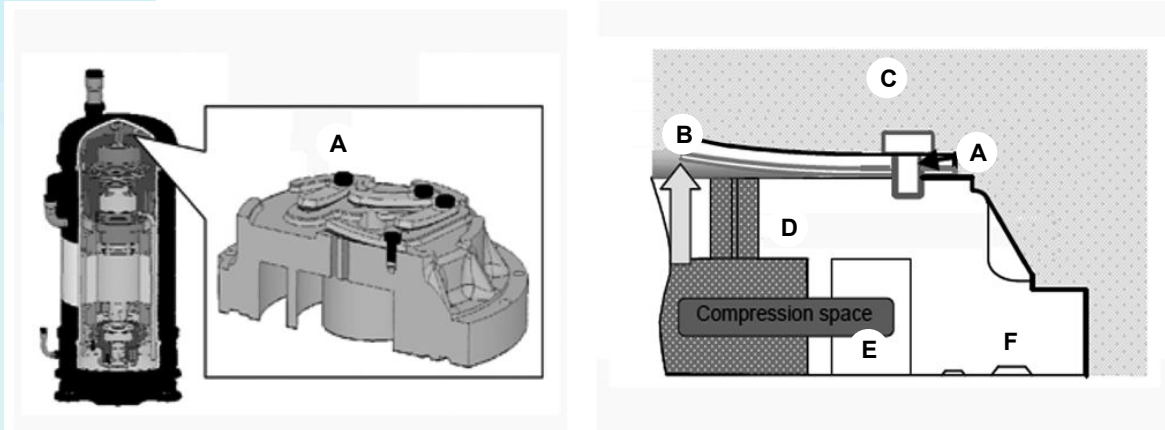
D	Refrigerating ability increased by supercooling circuit
E	Cooling capacity

### 2.4.7 DC Inverter Scroll Compressor

#### Compact design

The HITACHI DC Inverter Scroll compressor by HITACHI was designed to increase efficiency and reliability and to reduce power consumption.

#### DC Inverter Scroll compressor advantages

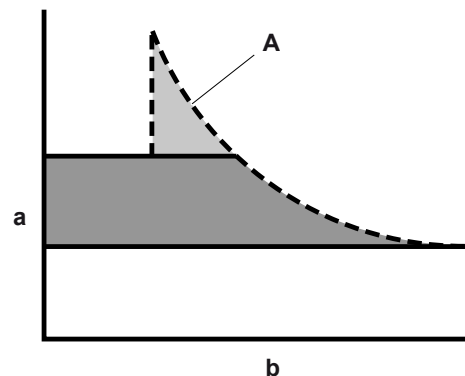


A	Release valve
B	valve open
C	discharge pressure space
D	hole for release valve
E	compression space
F	fixed scroll

The intermediate pressure features are drastically improved by incorporating an overpressure valve and optimising the orbital elevation force on the compressor spiral, which prevents charge losses from leaks. As a consequence, the intermediate pressure features are improved and they increase energy savings.

A	Over pressure in the new system
a	Pressure
b	Volum

The overpressure valve regulates the pressure, whereby increasing the efficiency and reliability of the compressor in the charge. This system ensures that the working pressure for the compressor is always optimal, no matter what the charge. The ratio between discharge pressure (Pd) and suction pressure (Ps) is optimal, as shown in the picture.



Motor heat is not added to the suction gas before compression, which reduces the discharge gas temperature. This is especially important in low suction temperatures. The discharge gas cools the motor sufficiently.

#### Lubrication

Taking into account that lubrication is one of the most important factors in maintaining the useful life of a compressor, HITACHI has developed a system based on the pressure differences between suction and discharge that a support pumps uses in the compressor base. As a result, homogeneous lubrication is obtained on all mobile parts of the compressor, demonstrating great reliability for its operational range, even at low frequencies.

**Protection against liquid return**

The mobile scroll rests in the box when the compressor is idle. When the compressor starts up, it increases the pressure in the chamber located under the scroll through two purge holes on the medium pressure section of the compression stroke. This pressure then pushes the scroll upwards, against the cabinet and seals the compression chamber.

It returns to the compressor as a liquid, the pressure increase that is generated then pushes the scroll downwards and breaks the seal, so that the liquid can return to the compressor body, where it evaporates, due to the high temperature.

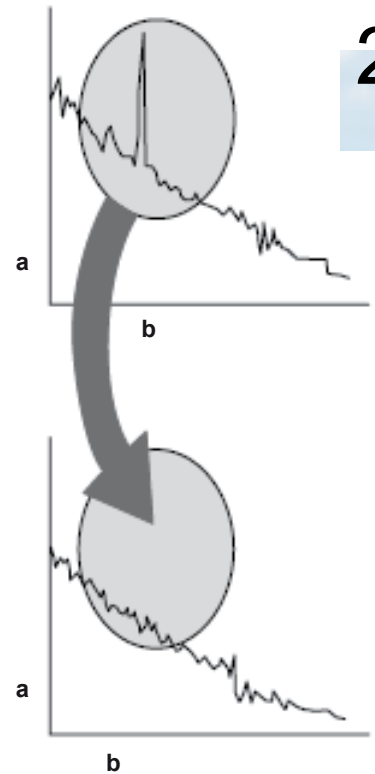
**2.4.8 Low noise level for compressor**

a	Noise
b	Frequency (Hz)

The Scroll compressor is very quiet, with little vibration because the compression points are uniformly distributed along the entire compression stroke.

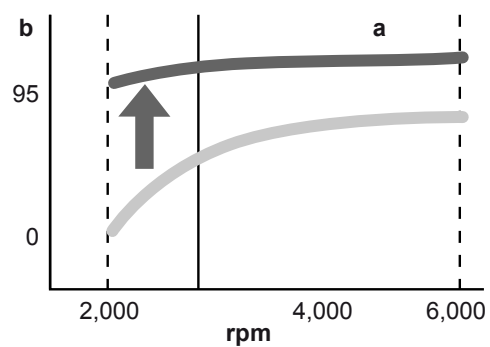
The minimal quantity of components used, operates in conjunction with the compressor crankcase, which acts as a silencer by improving noise distribution.

The sound pattern is high frequency, which means that an insulation cover can be used to convert it into very low level noise.



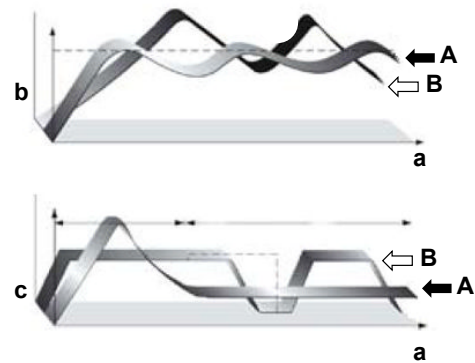
**2.4.9 Efficiency**

The use of a direct current compressor with a neodymium magnet improves its performance in the approximate margin of 30-40 Hz, where operating time is better than the compressor with inverter. Furthermore, to eliminate electromagnetic noise interferences and reach a lower level of noise, the rotor has been divided into two parts and the electric pole has been moved. The low-speed electrical features improve significantly, which reflects in the yearly running cost.



**2.4.10 Inverter Control**

A	DC INVERTER ES
B	Unit with constant speed
a	time
b	Room temperature
c	Compressor (rpm)



The Inverter system manages compressor speeds between 15 and 100 Hz, quickly reaching the set temperature and maintaining stable operations that save energy and reduce sound emission, because the compressor does not keep running continuously.

On the SET FREE models, the set temperature reaches high power very quickly, and then it maintains stable operations that save energy.

In the case of other equipment with a constant speed: the set temperature is reached slowly. Continuously connecting and disconnecting the unit in order to maintain the temperature, causes inefficient wear and wastes a great deal of energy.

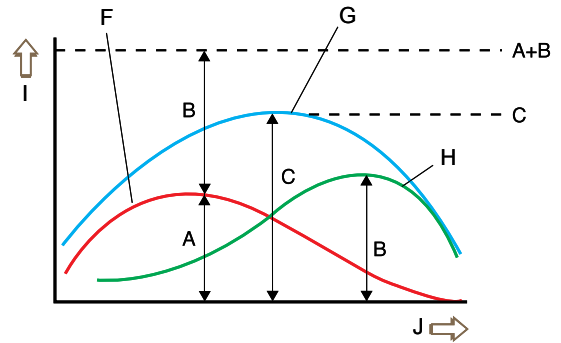
#### 2.4.11 Total reduced capacity for the outside unit

The SET FREE FSXN units enable the outdoor unit to have a capacity of 30% less in comparison with other air conditioning systems.

The image represents an installation in a typical building, with a peak morning heat load in the eastern area -A- equivalent to a unit of 6 HP. In the evening there is a heat load peak in the western area -B- equivalent to a unit of 7 HP. As such, a conventional system for the eastern and western area (-A- + -B-) needs a total installation of 6 HP + 7 HP = 13 HP.

The maximum simultaneous load for the entire building -C- is produced at midday and is equivalent to a capacity of 10 HP. A SET FREE FSXN system with a capacity of 10 HP can be selected, which can be directed towards the eastern or western areas, depending on what the system controls determine.

- A: morning peak heat load in the eastern area.  
 B: evening peak heat load in the western area.  
 C: maximum simultaneous load for the entire building.  
 F: eastern area load.  
 G: total load.  
 H: western area load.  
 I: load.  
 J: time.



2


**NOTE**

**The maximum load required in the eastern and western area must not be simultaneous.**

According to the data in the example:

$$\text{Saving in the installation} = (13 - 10) \text{ HP} / 13 \text{ HP} \times 100 = 23\%$$

Common selection type:

Convention system for the eastern and western area, which needs a total installation of 13 HP.

SET FREE FSXN unit selection:

Conventional system for eastern and western area, that takes into account the maximum simultaneous load for the entire building -C-.

$$(6 + 7) \text{ HP} / 0.80 \sim 0.85 \text{ HP}$$

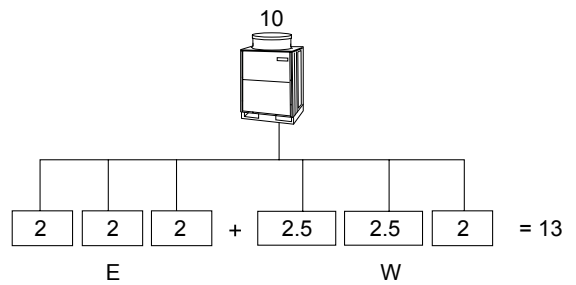
Given that a partial operation exists due to the variety of indoor units, the capacity of the outdoor unit can be selected according to the total load on the building in one day.

Refrigeration supply based on the load in each room.



**NOTE**

All the numeric values indicate horse power (HP).



$Load\ difference = 10 / 13 = 0.77$

**2.4.12 Wide range of operating possibilities**

Using SET FREE FSXN units in combination with an HVAC system for building (CS-NET WEB increases the performance of the installations even more. For example:

- Programme that avoids continuously running the units in rooms with no one in them and activates heating or cooling just before they are occupied.
- Set temperature limitation, which means that the units do not run at their maximum capacity if the comfort level does not require this.
- Lock functions from central control, which avoids incorrect or inefficient usage of the units.

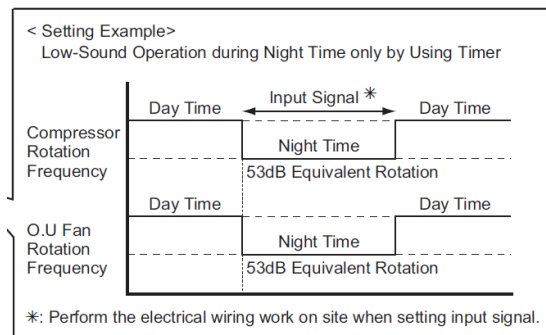
All of these functions, in addition to many others, are able to fully optimise the installation.

It is worth recalling that, due to the wide range of indoor units, it is always possible to find the unit with the power level and the type of installation that adjusts to your needs the best.

**2.4.13 Night mode (optional function)**

With the optional night mode function, the sound emission level for the outdoor unit can be set during specific periods of time to adapt it to its surrounding (for example, at night, near hospitals or homes, etc.)<sup>(1)</sup>.

You can choose between three emission level settings using the PCB on the outdoor unit.



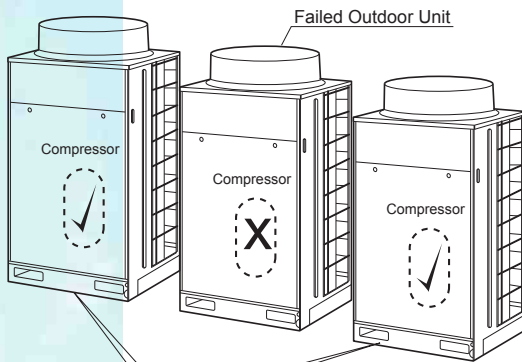
Function n°	Description	Sound pressure reduction <sup>(2)</sup>
11	Sound pressure setting 1 (standard value -2 dB)	56
12	Sound pressure setting 2 (standard value -5 dB)	53
13	Sound pressure setting 3 (standard value -8 dB)	50

- <sup>(1)</sup>The operating margin and the features are restricted because to the operating frequency of the compressor is limited.
  - Sound reduction setting 1: 80% of standard capacity.
  - Sound reduction setting 2: 60% of standard capacity.
  - Sound reduction setting 3: 40% of standard capacity.
- <sup>(2)</sup>The table indicates the approximate values for an outdoor 10 HP unit. In some cases, these values can be temporarily higher than those indicated in the table due to operating control conditions.

**i NOTE**

**The electrical installation on the outdoor unit needs to be supplemented in order to use the optional night mode function.**

**2.4.14 Emergency (backup) function**



Even if one unit is failed, the others can operate continuously. \*2

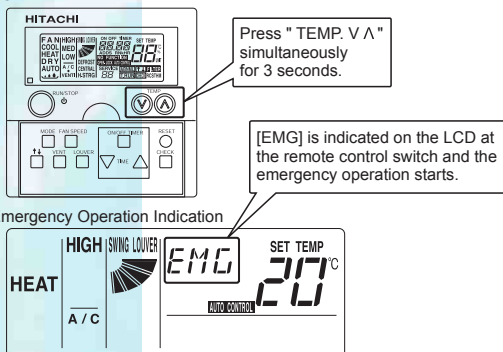
The emergency (backup) function avoids total system stoppage when there is a fault in one of the outdoor units in the same refrigeration cycle.

In the event of a fault in the compressor in one of the outdoor units, emergency mode can be enabled from the remote control.

**i NOTE**

- **There must be two or more outdoor units in the same refrigeration cycle for the emergency (backup) function to be used.**
- **Keeping the emergency (backup) function working for more than eight hours could lead to unit damage.**

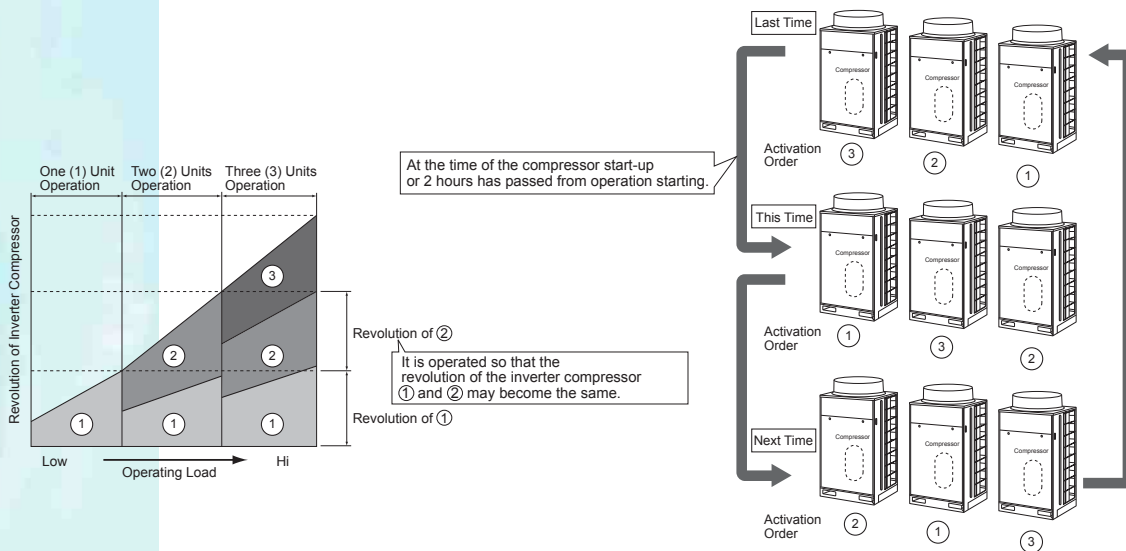
PC-ART



The emergency (backup) function can be enabled when the following alarm codes are indicated on the remote control screen:

Code	Category	Possible cause of the fault
06	Inverter fault	Abnormal inverter voltage
06.		Abnormal fan controller voltage
23		Discharge gas thermistor at top of compressor
51		Abnormal inverter current sensor
52		Triggering of the inverter current protection
53		Inverter error signal detection
54		Abnormal inverter fin temperature
23	Constant compressor speed fault	Discharge gas thermistor at top of compressor
39		Abnormal operating current in constant speed compressor

### 2.4.15 Outdoor unit rotation function



The load on the compressors can be reduced by setting the operating time of each outdoor unit<sup>(1)</sup>, <sup>(2)</sup>. Applying the same operating frequency to all compressors on the outdoor units in the same refrigeration cycle is equivalent to balancing their load, thus improving the durability of the outdoor units.

Example of rotation frequency control on Inverter compressors:



**NOTE**

- <sup>(1)</sup>There must be two or more outdoor units in the same refrigeration cycle for the outdoor unit rotation function to be used.
- <sup>(2)</sup>Comparison between using or not using the outdoor unit rotation function in the same system.



### 2.4.16 Control over operating values (optional function)

The following settings improve the operating values for the installation by adapting it to different environments.

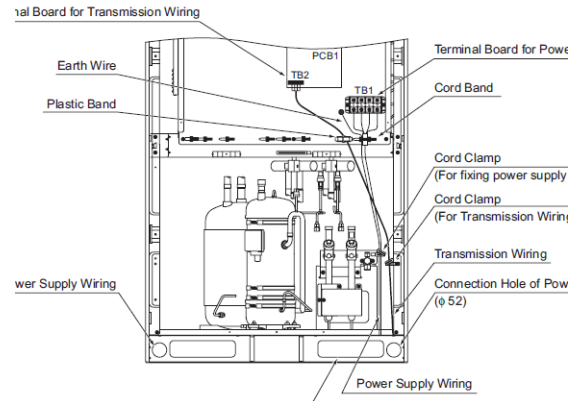
Setting method in the PCB on the outdoor unit			
Operating mode	Setting	Managed element	Set element
Cooling	Adjust the length of the pipes between the outdoor and indoor units.	Opening on the expansion valve on the indoor unit.	Objective super-heating value on the indoor unit heat exchanger.
	Capacity priority.	Rotation frequency for the compressors.	Objective suction pressure value for the compressor.
	Demand.		Electrical power demand 60/70/80/100%.
Heating	Adjustment in height between indoor units.	Opening on the expansion valve on the indoor unit.	Objective super-cooling value on the indoor unit heat exchanger.
	Capacity priority.	Rotation frequency for the compressors.	Objective discharge pressure value for the compressor.
	Start-up priority.	Opening on the expansion valve on the outdoor unit.	

## 2.5 Maintenance benefits

### 2.5.1 Access cover for installation and maintenance

The unit has a cover at the back that is divided into two parts, which protects the internal parts on the outdoor unit. All the connection and maintenance operations for the unit are made through this cover.

The unit connections are accessed through the upper part of the back cover. The lower part covers the connection for the refrigerant pipes and the liquid and gas stop valves (High and low pressure, according to operational configuration for the system.)



### 2.5.2 Availability of maintenance tools

#### ◆ HITACHI Service Tools

All installation functions of the HITACHI Service Tools software can also be used for unit maintenance (preventive or corrective). Any incident can be quickly detected and solved in a shorter time.

Additionally, the CSNET-WEB is also a powerful tool that is very useful for performing maintenance tasks.

HITACHI has a range of different control systems that can be used with the SET FREE outdoor units; consult the corresponding Technical Catalogue for the controls.



#### ◆ Monitoring the system and simplifying maintenance work

The HITACHI Service Tools software is a very powerful tool for the control and management of HVAC installations. To do so, it supervises the working order of the entire system and displays data that allows for potential incidents to be detected.

Management via software improves the advanced scheduling of planned technical stoppages and means that any unit can be inspected without altering the operation of the air conditioning system. The data obtained is processed and interpreted directly by the software, without the need to waste time or personnel on data reading or on-site checks.

#### ◆ Decrease in operation costs

Monitored operation allows for real-time observation of the performance of the entire air conditioning system. The control system is responsible for ensuring all parts work according to the foreseen conditions, with the maximum performance and efficiency at all times. In this situation, the utmost benefit is obtained from the entire installation at minimum operation costs.

Any range of values tending to be outside that foreseen is an indication of a situation that must be corrected as quickly as possible. The management software clearly displays situations of this type and, therefore, is an interesting ally for reducing costs generated by extraordinary maintenance stoppages.

The more in-depth analysis of the tendencies offers a starting point for realistic maintenance schedules, adapted to the operating conditions of each system.

## **2.6 Simple maintenance**

---

### **2.6.1 Optimised design to simplify maintenance**

The components of the indoor units of the entire range have a strong, long-lasting design bearing in mind the demanding requirements of the market insofar as maintenance cost reduction.

The interior structure of the units and the layout of the internal parts make any removal and assembly operations easier where technical work is required for some reason.

### **2.6.2 Minimum or zero maintenance**

All equipment and components on the SET FREE range of outdoor units have been designed for minimal, simple and easy maintenance operations.

### **2.6.3 Loyal to the HITACHI philosophy**

The outdoor units of the SETFREE range have been designed in strict compliance with the HITACHI philosophy that ensures the utmost reliability and reduces maintenance tasks to a minimum.



# 3. General data

# 3

## Index

3.1	General data.....	46
3.1.1	Outdoor units.....	46
3.1.1.1	General conditions.....	46
3.1.1.2	RAS-(8-12)FSXN.....	47
3.1.1.3	RAS-(14-18)FSXN.....	48
3.1.1.4	RAS-(20-24)FSXN.....	49
3.1.1.5	RAS-(26-30)FSXN.....	50
3.1.1.6	RAS-(32-36)FSXN.....	51
3.1.1.7	RAS-(38-42)FSXN.....	52
3.1.1.8	RAS-(44-48)FSXN.....	53
3.1.1.9	RAS-(50-54)FSXN.....	54
3.1.1.10	CH-(6.0-10.0)N1.....	55
3.2	Component data.....	56
3.2.1	Outdoor units RAS-(8-54)FSXN.....	56
3.3	Electrical data.....	60
3.3.1	Considerations.....	60
3.3.2	Outdoor units RAS-(8-54)FSXN.....	60

## 3.1 General data

### 3.1.1 Outdoor units

#### ◆ General conditions

- 1 The heating and cooling capacities indicated refer to outdoor units operating with the indoor units at 100% of their capacity.

Operating conditions.		Cooling	Heating
Indoor air inlet temperature	DB	27.0 °C	20.0 °C
	WB	19.0 °C	—
Outdoor air inlet temperature	DB	35.0 °C	7.0 °C
	WB	—	6.0 °C

DB: dry bulb; WB: wet bulb.

Pipe length: 7.5 m; pipe height: 0 m.

- 2 The sound pressure level has been measured under the following conditions:
- 1 m from the surface of the unit's service cover.
  - 1.5 m from floor level.
  - The data indicated is based on cooling mode. In the case of heating mode, the sound pressure level increases from 1 to 2 dB.
  - The data indicated has been measured in an anechoic chamber, so the reflected sound must be taken into account for installation.
- 3 If the main refrigerant pipe specified in the table is not available at the installation location, select the size given in brackets. In this case, prepare a suitable reducer.
- 4 There are no other combinations of units than those specified in the tables (20-54) HP.
- 5 The width indicated for the exterior dimensions takes into account a specific distance of 20 mm between the outdoor units.

**◆ RAS-(8-12)FSXN**

Model			RAS-8FSXN	RAS-10FSXN	RAS-12FSXN	
Supply voltage			3N~ 400V 50Hz			
Nominal cooling capacity	kW		22.4	28.0	33.5	
Nominal heating capacity	kW		25.0	31.5	37.5	
EER (cooling mode)			3.85	3.79	3.41	
COP (heating mode)			4.17	4.11	3.60	
Colour (Munsell code)			Natural grey (1.0Y 8.5/0.5)			
Sound pressure level (Night mode)	dB		58 (53)	58 (53)	60 (55)	
Outer dimensions	Height x Width x Depth	mm	1720 x 950 x 765	1720 x 950 x 765	1720 x 950 x 765	
Weight (net)	kg		210	210	210	
Weight (gross)	kg		225	225	225	
Refrigerant			R410A			
Flow control			Expansion valve controlled by microcomputer			
Compressor			Hermetic (Scroll)			
Model			E656DHD	E656DHD	E656DHD	
Quantity			1	1	1	
Motor power (Poles)	kW		4.8 (4)	6.0 (4)	7.2 (4)	
Refrigerant oil			FVC68D			
Type			FVC68D			
Load	L/Unit		5.0	5.0	6.0	
Heat exchanger			Multi-pass finned tube			
Condenser fan			Propeller fan			
Quantity			1	1	1	
Air flow speed	m <sup>3</sup> /min		155	170	175	
Motor power (Poles)	kW		0.33 (8)	0.44 (8)	0.49 (8)	
Size of pipes for outdoor unit: heat pump system (2 pipes)						
Liquid	mm		ø9.53 (3/8)	ø9.53 (3/8)	ø12.7 (1/2)	
	(in.)		(ø9.53 (3/8) - ø12.7 (1/2))	(ø9.53 (3/8) - ø12.7 (1/2))	(ø12.7 (1/2) - ø15.88 (5/8))	
Gas	mm		ø19.05 (3/4)	ø22.2 (7/8)	ø25.4 (1)	
	(in.)		(ø19.05 (3/4) - ø22.2 (7/8))	(ø22.2 (7/8) - ø25.4 (1))	(ø25.4 (1) - ø28.6 (1-1/8))	
Size of pipes for outdoor unit: heat recovery system (3 pipes)						
Liquid	mm		ø9.53 (3/8)	ø9.53 (3/8)	ø12.7 (1/2)	
	(in.)		(ø9.53 (3/8) - ø12.7 (1/2))	(ø9.53 (3/8) - ø12.7 (1/2))	(ø12.7 (1/2) - ø15.88 (5/8))	
Gas	mm		ø19.05 (3/4)	ø22.2 (7/8)	ø25.4 (1)	
	(in.)		(ø19.05 (3/4) - ø22.2 (7/8))	22.2 (7/8) - ø25.4 (1)	(ø25.4 (1) - ø28.6 (1-1/8))	
	mm		ø15.88 (5/8)	ø19.05 (3/4)	ø22.2 (7/8)	
	(in.)		(15.88 (5/8) - ø19.05 (3/4))	19.05 (3/4) - ø22.2 (7/8))	22.2 (7/8) - ø25.4 (1)	
Refrigerant charge			kg	6.5	6.5	7.0
Packaging measurements	Height x Width x Depth	mm	1895 x 990 x 810	1895 x 990 x 810	1895 x 990 x 810	
Approximate packaging measurements			m <sup>3</sup>	1.52	1.52	1.52

**◆ RAS-(14-18)FSXN**

Model			RAS-14FSXN	RAS-16FSXN	RAS-18FSXN
Supply voltage			3N~ 400V 50Hz		
Nominal cooling capacity	kW		40.0	45.0	50.0
Nominal heating capacity	kW		45.0	50.0	56.0
EER (cooling mode)			3.25	3.23	3.37
COP (heating mode)			3.89	3.90	3.81
Colour (Munsell code)			Natural grey (1.0Y 8.5/0.5)		
Sound pressure level (Night mode)	dB		62 (57)	62 (57)	63 (58)
Outer dimensions	Height x Width x Depth	mm	1720 x 1210 x 765	1720 x 1210 x 765	1720 x 1210 x 765
Weight (net)	kg		295	295	315
Weight (gross)	kg		315	315	335
Refrigerant			R410A		
Flow control			Expansion valve controlled by microcomputer		
Compressor			Hermetic (Scroll)		
Model			E656DHD + E655DH	E656DHD + E655DH	E656DHD + E855DH
Quantity			1 + 1	1 + 1	1 + 1
Motor power (Poles)	kW		4.8 (4) + 4.4 (2)	6.0 (4) + 4.4 (2)	6.0 (4) + 5.6 (2)
Refrigerant oil			FVC68D		
Type			FVC68D		
Load			L/Unit	7.9	7.9
Heat exchanger			Multi-pass finned tube		
Condenser fan			Propeller fan		
Quantity			1	1	1
Air flow speed	m <sup>3</sup> /min		195	195	195
Motor power (Poles)	kW		0.66 (8)	0.66 (8)	0.66 (8)
Size of pipes for outdoor unit: heat pump system (2 pipes)					
Liquid		mm (in.)	ø12.7 (1/2) (ø12.7 (1/2) - ø15.88 (5/8))	ø12.7 (1/2) (ø12.7 (1/2) - ø15.88 (5/8))	ø15.88 (5/8) (ø15.88 (5/8) - ø19.05 (3/4))
Gas		mm (in.)	ø25.4 (1) (ø25.4 (1) - ø28.6 (1-1/8))	ø28.6 (1-1/8) (ø28.6 (1-1/8) - ø31.75 (1-1/4))	ø28.6 (1-1/8) (ø28.6 (1-1/8) - ø31.75 (1-1/4))
Size of pipes for outdoor unit: heat recovery system (3 pipes)					
Liquid		mm (in.)	ø12.7 (1/2) (ø12.7 (1/2) - ø15.88 (5/8))	ø12.7 (1/2) (ø12.7 (1/2) - ø15.88 (5/8))	ø15.88 (5/8) (ø15.88 (5/8) - ø19.05 (3/4))
Gas		mm (in.)	ø25.4 (1) (ø25.4 (1) - ø28.6 (1-1/8))	ø28.6 (1-1/8) (ø28.6 (1-1/8) - ø31.75 (1-1/4))	ø28.6 (1-1/8) (ø28.6 (1-1/8) - ø31.75 (1-1/4))
		mm (in.)	ø22.2 (7/8) 22.2 (7/8) - ø25.4 (1))	ø22.2 (7/8) 22.2 (7/8) - ø25.4 (1))	ø22.2 (7/8) 22.2 (7/8) - ø25.4 (1))
Refrigerant charge			kg	9.0	10.5
Packaging measurements	Height x Width x Depth	mm	1895 x 1250 x 810	1895 x 1250 x 810	1895 x 1250 x 810
Approximate packaging measurements			m <sup>3</sup>	1.92	1.92



**◆ RAS-(20-24)FSXN**

Model			RAS-20FSXN	RAS-22FSXN	RAS-24FSXN	
Combination of outdoor units			RAS-8FSXN	RAS-8FSXN	RAS-10FSXN	
			RAS-12FSXN	RAS-14FSXN	RAS-14FSXN	
Supply voltage			3N~ 400V 50Hz			
Nominal cooling capacity	kW		56.0	61.5	69.0	
Nominal heating capacity	kW		63.0	69.0	77.5	
EER (cooling mode)			3.58	3.62	3.37	
COP (heating mode)			3.81	4.04	3.89	
Colour (Munsell code)			Natural grey (1.0Y 8.5/0.5)			
Sound pressure level (Night mode)	dB		62 (57)	63 (58)	63 (58)	
Outer dimensions	Height x Width x Depth	mm	1720 x 1920 x 765	1720 x 2180 x 765	1720 x 2180 x 765	
Weight (net)	kg		210 + 210	210 + 295	210 + 295	
Weight (gross)	kg		225 + 225	225 + 315	225 + 315	
Refrigerant			R410A			
Flow control			Expansion valve controlled by microcomputer			
Compressor			Hermetic (Scroll)			
Model			E656DHD + E656DHD	E656DHD + E656DHD + E655DH	E656DHD + E656DHD + E655DH	
Quantity			1 + 1	1 + 1 + 1	1 + 1 + 1	
Motor power (Poles)			kW	4.8 (4) + 7.2 (4)	4.8 (4) + 4.8 (4) + 4.4 (2)	6.0 (4) + 4.8 (4) + 4.4 (2)
Refrigerant oil			FVC68D			
Type						
Load			L/Unit	11.0	12.9	12.9
Heat exchanger			Multi-pass finned tube			
Condenser fan			Propeller fan			
Quantity			2	2	2	
Air flow speed			m <sup>3</sup> /min	155 + 175	155 + 195	170 + 195
Motor power (Poles)			kW	0.33 (8) + 0.49 (8)	0.33 (8) + 0.66 (8)	0.44 (8) + 0.66 (8)
Size of pipes for outdoor unit: heat pump system (2 pipes)						
Liquid			mm (in.)	ø15.88 (5/8) (ø15.88 (5/8) - ø19.05 (3/4))	ø15.88 (5/8) (ø15.88 (5/8) - ø19.05 (3/4))	ø15.88 (5/8) (ø15.88 (5/8) - ø19.05 (3/4))
Gas			mm (in.)	ø28.6 (1-1/8) (ø28.6 (1-1/8) - ø31.75 (1-1/4))	ø28.6 (1-1/8) (ø28.6 (1-1/8) - ø31.75 (1-1/4))	ø28.6 (1-1/8) (ø28.6 (1-1/8) - ø31.75 (1-1/4))
Size of pipes for outdoor unit: heat recovery system (3 pipes)						
Liquid			mm (in.)	ø15.88 (5/8) (ø15.88 (5/8) - ø19.05 (3/4))	ø15.88 (5/8) (ø15.88 (5/8) - ø19.05 (3/4))	ø15.88 (5/8) (ø15.88 (5/8) - ø19.05 (3/4))
Gas			mm (in.)	ø28.6 (1-1/8) (ø28.6 (1-1/8) - ø31.75 (1-1/4))	ø28.6 (1-1/8) (ø28.6 (1-1/8) - ø31.75 (1-1/4))	ø28.6 (1-1/8) (ø28.6 (1-1/8) - ø31.75 (1-1/4))
			mm (in.)	ø22.2 (7/8) 22.2 (7/8) - ø25.4 (1)	ø25.4 (1) (ø25.4 (1) - ø28.6 (1-1/8))	ø25.4 (1) (ø25.4 (1) - ø28.6 (1-1/8))
Refrigerant charge			kg	13.5	15.5	15.5
Approximate packaging measurements			m <sup>3</sup>	—	—	—

**◆ RAS-(26-30)FSXN**

Model			RAS-26FSXN	RAS-28FSXN	RAS-30FSXN
Combination of outdoor units			RAS-12FSXN	RAS-14FSXN	RAS-14FSXN
			RAS-14FSXN	RAS-14FSXN	RAS-16FSXN
Supply voltage			3N~ 400V 50Hz		
Nominal cooling capacity	kW		73.0	80.0	85.0
Nominal heating capacity	kW		82.5	90.0	95.0
EER (cooling mode)			3.38	3.25	3.24
COP (heating mode)			3.75	3.89	3.90
Colour (Munsell code)			Natural grey (1.0Y 8.5/0.5)		
Sound pressure level (Night mode)	dB		64 (59)	65 (60)	65 (60)
Outer dimensions	Height x Width x Depth	mm	1720 x 2180 x 765	1720 x 2440 x 765	1720 x 2440 x 765
Weight (net)	kg		210 + 295	295 + 295	295 + 295
Weight (gross)	kg		225 + 315	315 + 315	315 + 315
Refrigerant			R410A		
Flow control			Expansion valve controlled by microcomputer		
Compressor			Hermetic (Scroll)		
Model			E656DHD + E656DHD + E655DH	E656DHD + E655DH + E656DHD + E655DH	E656DHD + E655DH + E656DHD + E655DH
Quantity			1 + 1 + 1	1 + 1 + 1 + 1	1 + 1 + 1 + 1
Motor power (Poles)	kW		7.2 (4) + 4.8 (4) + 4.4 (2)	4.8 (4) + 4.4 (2) + 4.8 (4) + 4.4 (2)	4.8 (4) + 4.4 (2) + 6.0 (4) + 4.4 (2)
Refrigerant oil			FVC68D		
Load	L/Unit		13.9	15.8	15.8
Heat exchanger			Multi-pass finned tube		
Condenser fan			Propeller fan		
Quantity			2	2	2
Air flow speed	m <sup>3</sup> /min		175 + 195	195 + 195	195 + 195
Motor power (Poles)	kW		0.49 (8) + 0.66 (8)	0.66 (8) + 0.66 (8)	0.66 (8) + 0.66 (8)
Size of pipes for outdoor unit: heat pump system (2 pipes)					
Liquid	mm (in.)		ø19.05 (3/4) (ø19.05 (3/4) - ø22.2 (7/8))	ø19.05 (3/4) (ø19.05 (3/4) - ø22.2 (7/8))	ø19.05 (3/4) (ø19.05 (3/4) - ø22.2 (7/8))
Gas	mm (in.)		ø31.75 (1-1/4) (ø31.75 (1-1/4) - ø34.9 (1-3/8))	ø31.75 (1-1/4) (ø31.75 (1-1/4) - ø34.9 (1-3/8))	ø31.75 (1-1/4) (ø31.75 (1-1/4) - ø34.9 (1-3/8))
Size of pipes for outdoor unit: heat recovery system (3 pipes)					
Liquid	mm (in.)		ø19.05 (3/4) (ø19.05 (3/4) - ø22.2 (7/8))	ø19.05 (3/4) (ø19.05 (3/4) - ø22.2 (7/8))	ø19.05 (3/4) (ø19.05 (3/4) - ø22.2 (7/8))
Gas	mm (in.)		ø31.75 (1-1/4) (ø31.75 (1-1/4) - ø34.9 (1-3/8))	ø31.75 (1-1/4) (ø31.75 (1-1/4) - ø34.9 (1-3/8))	ø31.75 (1-1/4) (ø31.75 (1-1/4) - ø34.9 (1-3/8))
	mm (in.)		ø25.4 (1) (ø25.4 (1) - ø28.6 (1-1/8))	ø28.6 (1-1/8) (ø28.6 (1-1/8) - ø31.75 (1-1/4))	ø28.6 (1-1/8) (ø28.6 (1-1/8) - ø31.75 (1-1/4))
Refrigerant charge	kg		16.0	18.0	18.0
Approximate packaging measurements			m <sup>3</sup> —		

**◆ RAS-(32-36)FSXN**

Model			RAS-32FSXN	RAS-34FSXN	RAS-36FSXN
Combination of outdoor units			RAS-16FSXN	RAS-16FSXN	RAS-18FSXN
			RAS-16FSXN	RAS-18FSXN	RAS-18FSXN
Supply voltage			3N~ 400V 50Hz		
Nominal cooling capacity	kW		90.0	95.0	100.0
Nominal heating capacity	kW		100.0	106.0	112.0
EER (cooling mode)			3.23	3.30	3.37
COP (heating mode)			3.90	3.85	3.81
Colour (Munsell code)			Natural grey (1.0Y 8.5/0.5)		
Sound pressure level (Night mode)	dB		65 (60)	66 (61)	66 (61)
Outer dimensions	Height x Width x Depth	mm	1720 x 2440 x 765	1720 x 2440 x 765	1720 x 2440 x 765
Weight (net)	kg		295 + 295	295 + 315	315 + 315
Weight (gross)	kg		315 + 315	315 + 335	335 + 335
Refrigerant			R410A		
Flow control			Expansion valve controlled by microcomputer		
Compressor			Hermetic (Scroll)		
Model			E656DHD + E655DH + E656DHD + E655DH	E656DHD + E655DH + E656DHD + E855DH	E656DHD + E855DH + E656DHD + E855DH
Quantity			1 + 1 + 1 + 1	1 + 1 + 1 + 1	1 + 1 + 1 + 1
Motor power (Poles)	kW		6.0 (4) + 4.4 (2) + 6.0 (4) + 4.4 (2)	6.0 (4) + 4.4 (2) + 6.0 (4) + 5.6 (2)	6.0 (4) + 5.6 (2) + 6.0 (4) + 5.6 (2)
Refrigerant oil			FVC68D		
Load	L/Unit		15.8	15.8	15.8
Heat exchanger			Multi-pass finned tube		
Condenser fan			Propeller fan		
Quantity			2	2	2
Air flow speed	m <sup>3</sup> /min		195 + 195	195 + 195	195 + 195
Motor power (Poles)	kW		0.66 (8) + 0.66 (8)	0.66 (8) + 0.66 (8)	0.66 (8) + 0.66 (8)
Size of pipes for outdoor unit: heat pump system (2 pipes)					
Liquid	mm (in.)		ø19.05 (3/4) (ø19.05 (3/4) - ø22.2 (7/8))	ø19.05 (3/4) (ø19.05 (3/4) - ø22.2 (7/8))	ø19.05 (3/4) (ø19.05 (3/4) - ø22.2 (7/8))
Gas	mm (in.)		ø31.75 (1-1/4) (ø31.75 (1-1/4) - ø34.9 (1-3/8))	ø31.75 (1-1/4) (ø31.75 (1-1/4) - ø34.9 (1-3/8))	ø38.1 (1-1/2) (ø38.1 (1-1/2) - ø41.3 (1-5/8))
Size of pipes for outdoor unit: heat recovery system (3 pipes)					
Liquid	mm (in.)		ø19.05 (3/4) (ø19.05 (3/4) - ø22.2 (7/8))	ø19.05 (3/4) (ø19.05 (3/4) - ø22.2 (7/8))	ø19.05 (3/4) (ø19.05 (3/4) - ø22.2 (7/8))
Gas	mm (in.)		ø31.75 (1-1/4) (ø31.75 (1-1/4) - ø34.9 (1-3/8))	ø31.75 (1-1/4) (ø31.75 (1-1/4) - ø34.9 (1-3/8))	ø31.75 (1-1/4) (ø31.75 (1-1/4) - ø34.9 (1-3/8))
	mm (in.)		ø28.6 (1-1/8) (ø28.6 (1-1/8) - ø31.75 (1-1/4))	ø28.6 (1-1/8) (ø28.6 (1-1/8) - ø31.75 (1-1/4))	ø28.6 (1-1/8) (ø28.6 (1-1/8) - ø31.75 (1-1/4))
Refrigerant charge	kg		18.0	19.5	21.0
Approximate packaging measurements			m <sup>3</sup> —		

**◆ RAS-(38-42)FSXN**

Model			RAS-38FSXN	RAS-40FSXN	RAS-42FSXN
Combination of outdoor units			RAS-12FSXN	RAS-12FSXN	RAS-12FSXN
			RAS-12FSXN	RAS-12FSXN	RAS-12FSXN
			RAS-14FSXN	RAS-16FSXN	RAS-18FSXN
Supply voltage			3N~ 400V 50Hz		
Nominal cooling capacity	kW	109.0	112.0	118.0	
Nominal heating capacity	kW	118.0	125.0	132.0	
EER (cooling mode)		3.29	3.34	3.32	
COP (heating mode)		3.87	3.71	3.65	
Colour (Munsell code)			Natural grey (1.0Y 8.5/0.5)		
Sound pressure level (Night mode)	dB	66 (61)	66 (61)	66 (61)	
Outer dimensions	Height x Width x Depth	mm	1720 x 3150 x 765	1720 x 3150 x 765	1720 x 3150 x 765
Weight (net)	kg	210 + 210 + 295	210 + 210 + 295	210 + 210 + 315	
Weight (gross)	kg	225 + 225 + 315	225 + 225 + 315	225 + 225 + 335	
Refrigerant			R410A		
Flow control			Expansion valve controlled by microcomputer		
Compressor			Hermetic (Scroll)		
Model			E656DHD + E656DHD + E656DHD + E655DH	E656DHD + E656DHD + E656DHD + E655DH	E656DHD + E656DHD + E656DHD + E855DH
Quantity			1 + 1 + 1 + 1	1 + 1 + 1 + 1	1 + 1 + 1 + 1
Motor power (Poles)	kW	7.2 (4) + 7.2 (4) + 4.8 (4) + 4.4 (2)	7.2 (4) + 7.2 (4) + 6.0 (4) + 4.4 (2)	7.2 (4) + 7.2 (4) + 6.0 (4) + 5.6 (2)	
Refrigerant oil			FVC68D		
	Type		FVC68D		
	Load	L/Unit	19.9	19.9	19.9
Heat exchanger			Multi-pass finned tube		
Condenser fan			Propeller fan		
Quantity			3	3	3
Air flow speed	m <sup>3</sup> /min	175 + 175 + 195	175 + 175 + 195	175 + 175 + 195	
Motor power (Poles)	kW	0.49 (8) + 0.49 (8) + 0.66 (8)	0.49 (8) + 0.49 (8) + 0.66 (8)	0.49 (8) + 0.49 (8) + 0.66 (8)	
Size of pipes for outdoor unit: heat pump system (2 pipes)					
	Liquid	mm (in.)	ø19.05 (3/4) (ø19.05 (3/4) - ø22.2 (7/8))	ø19.05 (3/4) (ø19.05 (3/4) - ø22.2 (7/8))	ø19.05 (3/4) (ø19.05 (3/4) - ø22.2 (7/8))
	Gas	mm (in.)	ø38.1 (1-1/2) (ø38.1 (1-1/2) - ø41.3 (1-5/8))	ø38.1 (1-1/2) (ø38.1 (1-1/2) - ø41.3 (1-5/8))	ø38.1 (1-1/2) (ø38.1 (1-1/2) - ø41.3 (1-5/8))
Size of pipes for outdoor unit: heat recovery system (3 pipes)					
	Liquid	mm (in.)	ø19.05 (3/4) (ø19.05 (3/4) - ø22.2 (7/8))	ø19.05 (3/4) (ø19.05 (3/4) - ø22.2 (7/8))	ø19.05 (3/4) (ø19.05 (3/4) - ø22.2 (7/8))
	Gas	mm (in.)	ø38.1 (1-1/2) (ø38.1 (1-1/2) - ø41.3 (1-5/8))	ø38.1 (1-1/2) (ø38.1 (1-1/2) - ø41.3 (1-5/8))	ø38.1 (1-1/2) (ø38.1 (1-1/2) - ø41.3 (1-5/8))
	Gas	mm (in.)	ø31.75 (1-1/4) (ø31.75 (1-1/4) - ø34.9 (1-3/8))	ø31.75 (1-1/4) (ø31.75 (1-1/4) - ø34.9 (1-3/8))	ø31.75 (1-1/4) (ø31.75 (1-1/4) - ø34.9 (1-3/8))
Refrigerant charge	kg	23.0	23.0	24.5	
Approximate packaging measurements			m <sup>3</sup>	—	—

**◆ RAS-(44-48)FSXN**

Model		RAS-44FSXN	RAS-46FSXN	RAS-48FSXN
Combination of outdoor units		RAS-12FSXN	RAS-12FSXN	RAS-12FSXN
		RAS-14FSXN	RAS-16FSXN	RAS-18FSXN
		RAS-18FSXN	RAS-18FSXN	RAS-18FSXN
Supply voltage		3N~ 400V 50Hz		
Nominal cooling capacity	kW	125.0	132.0	136.0
Nominal heating capacity	kW	140.0	145.0	150.0
EER (cooling mode)		3.27	3.16	3.24
COP (heating mode)		3.75	3.71	3.74
Colour (Munsell code)		Natural grey (1.0Y 8.5/0.5)		
Sound pressure level (Night mode)	dB	67 (62)	67 (62)	67 (62)
Outer dimensions	Height x Width x Depth	mm	1720 x 3410 x 765	1720 x 3410 x 765
Weight (net)	kg	210 + 295 + 315	210 + 295 + 315	210 + 315 + 315
Weight (gross)	kg	225 + 315 + 335	225 + 315 + 335	225 + 335 + 335
Refrigerant		R410A		
Flow control		Expansion valve controlled by microcomputer		
Compressor		Hermetic (Scroll)		
Model		E656DHD + E656DHD + E655DH + E656DHD + E855DH	E656DHD + E656DHD + E655DH + E656DHD + E855DH	E656DHD + E656DHD + E855DH + E656DHD + E855DH
Quantity		1 + 1 + 1 + 1 + 1	1 + 1 + 1 + 1 + 1	1 + 1 + 1 + 1 + 1
Motor power (Poles)	kW	7.2 (4) + 4.8 (4) + 4.4 (2) + 6.0 (4) + 5.6 (2)	7.2 (4) + 6.0 (4) + 4.4 (2) + 6.0 (4) + 5.6 (2)	7.2 (4) + 6.0 (4) + 5.6 (2) + 6.0 (4) + 5.6 (2)
Refrigerant oil		FVC68D		
Type				
Load	L/Unit	21.8	21.8	21.8
Heat exchanger		Multi-pass finned tube		
Condenser fan		Propeller fan		
Quantity		3	3	3
Air flow speed	m <sup>3</sup> /min	175 + 195 + 195	175 + 195 + 195	175 + 195 + 195
Motor power (Poles)	kW	0.49 (8) + 0.66 (8) + 0.66 (8)	0.49 (8) + 0.66 (8) + 0.66 (8)	0.49 (8) + 0.66 (8) + 0.66 (8)
Size of pipes for outdoor unit: heat pump system (2 pipes)				
Liquid	mm (in.)	ø19.05 (3/4) (ø19.05 (3/4) - ø22.2 (7/8))	ø19.05 (3/4) (ø19.05 (3/4) - ø22.2 (7/8))	ø19.05 (3/4) (ø19.05 (3/4) - ø22.2 (7/8))
Gas	mm (in.)	ø38.1 (1-1/2) (ø38.1 (1-1/2) - ø41.3 (1-5/8))	ø38.1 (1-1/2) (ø38.1 (1-1/2) - ø41.3 (1-5/8))	ø38.1 (1-1/2) (ø38.1 (1-1/2) - ø41.3 (1-5/8))
Size of pipes for outdoor unit: heat recovery system (3 pipes)				
Liquid	mm (in.)	ø19.05 (3/4) (ø19.05 (3/4) - ø22.2 (7/8))	ø19.05 (3/4) (ø19.05 (3/4) - ø22.2 (7/8))	ø19.05 (3/4) (ø19.05 (3/4) - ø22.2 (7/8))
Gas	mm (in.)	ø38.1 (1-1/2) (ø38.1 (1-1/2) - ø41.3 (1-5/8))	ø38.1 (1-1/2) (ø38.1 (1-1/2) - ø41.3 (1-5/8))	ø38.1 (1-1/2) (ø38.1 (1-1/2) - ø41.3 (1-5/8))
	mm (in.)	ø31.75 (1-1/4) (ø31.75 (1-1/4) - ø34.9 (1-3/8))	ø31.75 (1-1/4) (ø31.75 (1-1/4) - ø34.9 (1-3/8))	ø31.75 (1-1/4) (ø31.75 (1-1/4) - ø34.9 (1-3/8))
Refrigerant charge	kg	26.5	26.5	28.0
Approximate packaging measurements		m <sup>3</sup>	—	—

**◆ RAS-(50-54)FSXN**

Model			RAS-50FSXN	RAS-52FSXN	RAS-54FSXN
Combination of outdoor units			RAS-14FSXN	RAS-16FSXN	RAS-18FSXN
			RAS-18FSXN	RAS-18FSXN	RAS-18FSXN
			RAS-18FSXN	RAS-18FSXN	RAS-18FSXN
Supply voltage			3N~ 400V 50Hz		
Nominal cooling capacity	kW	140.0	145.0	150.0	
Nominal heating capacity	kW	155.0	160.0	165.0	
EER (cooling mode)		3.33	3.32	3.37	
COP (heating mode)		3.98	3.98	4.01	
Colour (Munsell code)			Natural grey (1.0Y 8.5/0.5)		
Sound pressure level (Night mode)	dB	67 (62)	67 (62)	67 (62)	
Outer dimensions	Height x Width x Depth	mm	1720 x 3670 x 765	1720 x 3670 x 765	1720 x 3670 x 765
Weight (net)	kg	295 + 315 + 315	295 + 315 + 315	315 + 315 + 315	
Weight (gross)	kg	315 + 335 + 335	315 + 335 + 335	335 + 335 + 335	
Refrigerant			R410A		
Flow control			Expansion valve controlled by microcomputer		
Compressor			Hermetic (Scroll)		
Model			E656DHD + E655DH + E656DHD + E855DH + E656DHD + E855DH	E656DHD + E655DH + E656DHD + E855DH + E656DHD + E855DH	E656DHD + E855DH + E656DHD + E855DH + E656DHD + E855DH
Quantity			1 + 1 + 1 + 1 + 1 + 1	1 + 1 + 1 + 1 + 1 + 1	1 + 1 + 1 + 1 + 1 + 1
Motor power (Poles)			4.8 (4) + 4.4 (2) + 6.0 (4) + 5.6 (2) + 6.0 (4) + 5.6 (2)	6.0 (4) + 4.4 (2) + 6.0 (4) + 5.6 (2) + 6.0 (4) + 5.6 (2)	6.0 (4) + 5.6 (2) + 6.0 (4) + 5.6 (2) + 6.0 (4) + 5.6 (2)
Refrigerant oil			FVC68D		
Type			FVC68D		
Load			L/Unit	23.7	23.7
Heat exchanger			Multi-pass finned tube		
Condenser fan			Propeller fan		
Quantity			3	3	3
Air flow speed			m <sup>3</sup> /min	195 + 195 + 195	195 + 195 + 195
Motor power (Poles)			kW	0.66 (8) + 0.66 (8) + 0.66 (8)	0.66 (8) + 0.66 (8) + 0.66 (8)
Size of pipes for outdoor unit: heat pump system (2 pipes)					
Liquid			mm (in.)	ø19.05 (3/4) (ø19.05 (3/4) - ø22.2 (7/8))	ø19.05 (3/4) (ø19.05 (3/4) - ø22.2 (7/8))
Gas			mm (in.)	ø38.1 (1-1/2) (ø38.1 (1-1/2) - ø41.3 (1-5/8))	ø38.1 (1-1/2) (ø38.1 (1-1/2) - ø41.3 (1-5/8))
Size of pipes for outdoor unit: heat recovery system (3 pipes)					
Liquid			mm (in.)	ø19.05 (3/4) (ø19.05 (3/4) - ø22.2 (7/8))	ø19.05 (3/4) (ø19.05 (3/4) - ø22.2 (7/8))
Gas			mm (in.)	ø38.1 (1-1/2) (ø38.1 (1-1/2) - ø41.3 (1-5/8))	ø38.1 (1-1/2) (ø38.1 (1-1/2) - ø41.3 (1-5/8))
			mm (in.)	ø31.75 (1-1/4) (ø31.75 (1-1/4) - ø34.9 (1-3/8))	ø31.75 (1-1/4) (ø31.75 (1-1/4) - ø34.9 (1-3/8))
Refrigerant charge			kg	30.0	31.5
Approximate packaging measurements			m <sup>3</sup>	—	—

**◆ CH-(6.0-10.0)N1**

MODEL		CH-6.0N1	CH-10.0N1
Rated power	HP	CV ≤ 6	6 < CV ≤ 10
Maximum number of indoor units	–	7	8
Electricity demand	W	20	20
Outer dimensions			
Height	mm	191	
Width	mm	301	
Length	mm	214	
Net weight	kg	7	
Refrigerant	–	R410A (Factory-charged corrosion-proof nitrogen)	
Refrigerant pipe connections	–	Flared connections and/or Flange (Factory-supplied)	
Refrigerant lines from the outdoor unit*		Flared connections with nuts	
Liquid line	–	-	
Gas line			
Low pressure	mm (in)	Ø15.88 (5/8) - Ø19.05 (3/4)	Ø19.05 (3/4) - Ø22.2 (7/8)
High pressure	mm (in)	Ø12.7 (1/2) - Ø15.88 (5/8)	Ø15.88 (5/8) - Ø19.05 (3/4)
Refrigerant lines from the indoor unit*			
Liquid line	–	-	
Gas line	mm (in)	Ø12.7 (1/2) - Ø15.88 (5/8)	Ø19.05 (3/4) - Ø22.2 (7/8)

3

## 3.2 Component data

### 3.2.1 Outdoor units RAS-(8-54)FSXN

#### RAS-(8-14)FSXN

PART	MODEL	RAS-8FSXN	RAS-10FSXN	RAS-12FSXN	RAS-14FSXN	
Heat exchanger	Type	Multi-pass finned tube				
	Tube material	Copper				
	Outer diameter	mm	7	7	7	7
	Rows of tubes		2	2	2	2
	No. of tubes in the evaporator		136	136	136	136
	Fin material	Aluminium				
	Space between fins	mm	1.7	1.7	1.7	1.7
	Maximum operating pressure	MPa	4.15	4.15	4.15	4.15
	Total front area	m <sup>2</sup>	2.47	2.47	2.47	2.84
	No. of evaporators per unit		1	1	1	1
Fan	Fan type	Large diameter fan (propeller)				
	Fans per unit		1	1	1	1
	Outer diameter	mm	644	644	644	644
	Rotational speed	rpm	750	825	850	930
	Nominal air flow	m <sup>3</sup> /min	155	170	175	195
Motor	Shell	Splash-proof				
	Starting	Direct current control				
	Rated power	W	330	440	490	660
	Quantity		1	1	1	1
	Insulation class		E	E	E	E



**RAS-(16-22)FSXN**

PART	MODEL	RAS-16FSXN	RAS-18FSXN	RAS-20FSXN	RAS-22FSXN	
Heat exchanger	Type	Multi-pass finned tube				
	Tube material	Copper				
	Outer diameter	mm	7	7	7	7
	Rows of tubes		2	3	2+2	2+2
	No. of tubes in the evaporator		136	204	136+136	136+136
	Fin material	Aluminium				
	Space between fins	mm	1.7	1.7	1.7	1.7
	Maximum operating pressure	MPa	4.15	4.15	4.15	4.15
	Total front area	m <sup>2</sup>	2.84	2.84	2.47+2.47	2.47+2.84
	No. of evaporators per unit		1	1	2	2
Fan	Fan type	Large diameter fan (propeller)				
	Fans per unit		1	1	2	2
	Outer diameter	mm	644	644	644+644	644+644
	Rotational speed	rpm	930	930	750+850	750+930
	Nominal air flow	m <sup>3</sup> /min	195	195	155+175	155+195
Motor	Shell	Splash-proof				
	Starting	Direct current control				
	Rated power	W	660	660	330+490	330+660
	Quantity		1	1	2	2
	Insulation class		E	E	E+E	E+E

**RAS-(24-30)FSXN**

PART	MODEL	RAS-24FSXN	RAS-26FSXN	RAS-28FSXN	RAS-30FSXN	
Heat exchanger	Type	Multi-pass finned tube				
	Tube material	Copper				
	Outer diameter	mm	7	7	7	7
	Rows of tubes		2+2	2+2	2+2	2+2
	No. of tubes in the evaporator		136+136	136+136	136+136	136+136
	Fin material	Aluminium				
	Space between fins	mm	1.7	1.7	1.7	1.7
	Maximum operating pressure	MPa	4.15	4.15	4.15	4.15
	Total front area	m <sup>2</sup>	2.47+2.84	2.47+2.84	2.84+2.84	2.84+2.84
	No. of evaporators per unit		2	2	2	2
Fan	Fan type	Large diameter fan (propeller)				
	Fans per unit		2	2	2	2
	Outer diameter	mm	644+644	644+644	644+644	644+644
	Rotational speed	rpm	825+930	850+930	930+930	930+930
	Nominal air flow	m <sup>3</sup> /min	170+195	175+195	195+195	195+195
Motor	Shell	Splash-proof				
	Starting	Direct current control				
	Rated power	W	440+660	490+660	660+660	660+660
	Quantity		2	2	2	2
	Insulation class		E+E	E+E	E+E	E+E

**RAS-(32-38)FSXN**

PART	MODEL	RAS-32FSXN	RAS-34FSXN	RAS-36FSXN	RAS-38FSXN	
Heat exchanger	Type	Multi-pass finned tube				
	Tube material	Copper				
	Outer diameter	mm	7	7	7	7
	Rows of tubes		2+2	2+3	3+3	2+2+2
	No. of tubes in the evaporator		136+136	136+204	204+204	136+136+136
	Fin material	Aluminium				
	Space between fins	mm	1.7	1.7	1.7	1.7
	Maximum operating pressure	MPa	4.15	4.15	4.15	4.15
	Total front area	m <sup>2</sup>	2.84+2.84	2.84+2.84	2.84+2.84	2.47+2.47+2.84
	No. of evaporators per unit		2	2	2	3
Fan	Fan type	Large diameter fan (propeller)				
	Fans per unit		2	2	2	3
	Outer diameter	mm	644+644	644+644	644+644	644+644+644
	Rotational speed	rpm	930+930	930+930	930+930	850+850+930
	Nominal air flow	m <sup>3</sup> /min	195+195	195+195	195+195	175+175+195
Motor	Shell	Splash-proof				
	Starting	Direct current control				
	Rated power	W	660+660	660+660	660+660	490+490+660
	Quantity		2	2	2	3
	Insulation class		E+E	E+E	E+E	E+E+E

**RAS-(40-46)FSXN**

PART	MODEL	RAS-40FSXN	RAS-42FSXN	RAS-44FSXN	RAS-46FSXN	
Heat exchanger	Type	Multi-pass finned tube				
	Tube material	Copper				
	Outer diameter	mm	7	7	7	7
	Rows of tubes		2+2+2	2+2+3	2+2+3	2+2+3
	No. of tubes in the evaporator		136+136+136	136+136+204	136+136+204	136+136+204
	Fin material	Aluminium				
	Space between fins	mm	1.7	1.7	1.7	1.7
	Maximum operating pressure	MPa	4.15	4.15	4.15	4.15
	Total front area	m <sup>2</sup>	2.47+2.47+2.84	2.47+2.47+2.84	2.47+2.84+2.84	2.47+2.84+2.84
	No. of evaporators per unit		3	3	3	3
Fan	Fan type	Large diameter fan (propeller)				
	Fans per unit		3	3	3	3
	Outer diameter	mm	644+644+644	644+644+644	644+644+644	644+644+644
	Rotational speed	rpm	850+850+930	850+850+930	850+930+930	850+930+930
	Nominal air flow	m <sup>3</sup> /min	175+175+195	175+175+195	175+195+195	175+195+195
Motor	Shell	Splash-proof				
	Starting	Direct current control				
	Rated power	W	490+490+660	490+490+660	490+660+660	490+660+660
	Quantity		3	3	3	3
	Insulation class		E+E+E	E+E+E	E+E+E	E+E+E

**RAS-(48-54)FSXN**

PART	MODEL	RAS-48FSXN	RAS-50FSXN	RAS-52FSXN	RAS-54FSXN	
Heat exchanger	Type	Multi-pass finned tube				
	Tube material	Copper				
	Outer diameter	mm	7	7	7	7
	Rows of tubes		2+3+3	2+3+3	2+3+3	3+3+3
	No. of tubes in the evaporator		136+204+204	136+204+204	136+204+204	204+204+204
	Fin material	Aluminium				
	Space between fins	mm	1.7	1.7	1.7	1.7
	Maximum operating pressure	MPa	4.15	4.15	4.15	4.15
	Total front area	m <sup>2</sup>	2.47+2.84+2.84	2.84+2.84+2.84	2.84+2.84+2.84	2.84+2.84+2.84
	No. of evaporators per unit		3	3	3	3
Fan	Fan type	Large diameter fan (propeller)				
	Fans per unit		3	3	3	3
	Outer diameter	mm	644+644+644	644+644+644	644+644+644	644+644+644
	Rotational speed	rpm	850+930+930	930+930+930	930+930+930	930+930+930
	Nominal air flow	m <sup>3</sup> /min	175+195+195	195+195+195	195+195+195	195+195+195
Motor	Shell	Splash-proof				
	Starting	Direct current control				
	Rated power	W	490+660+660	660+660+660	660+660+660	660+660+660
	Quantity		3	3	3	3
	Insulation class		E+E+E	E+E+E	E+E+E	E+E+E

3

### 3.3 Electrical data

#### 3.3.1 Considerations

Key:

- U: power supply.
- PH: phase.
- f: frequency.
- STC: start-up current.
- RNC: operating current.
- IPT: total input power.
- MC: maximum current.



#### NOTE

- *The specifications given in the following tables are subject to change without prior notice.*
- *The data is based on the nominal frequency range of the compressor with a combination at 100% of the capacity of the indoor units.*
- *This data is based on the same conditions of nominal cooling and heating capacity.*
- *The compressor is started up by an inverter, so the start-up current is extremely low.*

#### 3.3.2 Outdoor units RAS-(8-54)FSXN

Model	Main unit power supply			Applicable voltage		STC	Cooling		Heating		MC (A)
	U (V)	PH	f (Hz)	Max. U (V)	Min. U (V)		IPT (kW)	RNC (A)	IPT (kW)	RNC (A)	
RAS-8FSXN	400	3N~	50	440	360	8	9.3	5.82	9.6	6.00	12
RAS-10FSXN						8	11.9	7.39	12.3	7.66	16
RAS-12FSXN						8	15.7	9.82	16.7	10.42	22
RAS-14FSXN						95	20.2	12.31	18.8	11.57	26
RAS-16FSXN						95	22.6	13.93	20.8	12.82	29
RAS-18FSXN						113	24.1	14.84	23.8	14.70	31
RAS-20FSXN						24	25.0	15.64	26.5	16.54	34
RAS-22FSXN						106	27.7	17.00	27.6	17.06	36
RAS-24FSXN						111	33.3	20.47	32.2	19.94	43
RAS-26FSXN						114	35.1	21.58	35.5	21.99	46
RAS-28FSXN						118	40.4	24.62	37.6	23.14	53
RAS-30FSXN						122	42.8	26.24	39.6	24.39	56
RAS-32FSXN						122	45.2	27.86	41.6	25.64	59
RAS-34FSXN						140	46.7	28.77	44.6	27.52	61
RAS-36FSXN						144	48.2	29.68	47.6	29.40	63
RAS-38FSXN						133	53.6	33.12	49.0	30.47	70
RAS-40FSXN						133	54.0	33.57	54.2	33.66	70
RAS-42FSXN						151	57.2	35.52	58.2	36.20	76
RAS-44FSXN						155	62.0	38.20	60.4	37.35	81
RAS-46FSXN						160	67.6	41.78	63.1	39.04	88
RAS-48FSXN	163	67.9	41.93	64.8	40.15	88					
RAS-50FSXN	167	68.4	41.99	63.2	38.97	89					
RAS-52FSXN	172	70.8	43.61	65.2	40.22	92					
RAS-54FSXN	176	72.3	44.52	66.6	41.10	94					

# 4. System selection procedure

## Index

4.1	Selection guide.....	62
4.2	Selection procedure.....	65
4.2.1	Cooling mode.....	66
4.2.2	Heating mode.....	69
4.3	Nominal cooling capacity tables.....	71
4.4	Nominal heating capacity tables.....	95
4.5	Outdoor unit capacity with total horsepower of combined indoor unit.....	120
4.6	Tables for 100% combination cooling capacity.....	136
4.7	Tables for 100% combination heating capacity.....	145
4.8	Correction factor depending on the pipe length.....	158
4.9	Correction factor depending on defrost.....	162
4.10	Sensible heat factor (SHF).....	163
4.11	Compatibility.....	165
4.11.1	Examples of different H-LINK and H-LINK II systems.....	165

4

## 4.1 Selection guide

The following procedure describes an example of the parameters, the necessary steps and the values to be considered to select the most suitable FSXN outdoor unit from the SET FREE series.

Considering the disposition of the building, the indoor units and the distribution of the air and refrigerant flow, the unit whose characteristics make it the most efficient and offer a greater level of comfort will be selected.

The location of the outdoor unit must take into account the ease of access for installation and maintenance work.

The "total reduced capacity of the outdoor unit" is the result of the wide range of operation capacity control available in SET FREE systems. This capacity means that the outdoor unit selects from a total maximum power (HP) combination of 130% and a total minimum power (HP) combination of 50% by combining indoor units in comparison with the capacity of the outdoor unit.

The possibilities of the FSXN series are shown in the following table:

Outdoor unit model	Indoor unit			
	Minimum combination capacity (HP)	Maximum combination capacity (HP)	Combination quantity	Minimum individual operation capacity (HP)
RAS-8FSXN	4.0	10.4	2 to 13	0.8
RAS-10FSXN	5.0	13.0	2 to 16	0.8
RAS-12FSXN	6.0	15.6	2 to 19	0.8
RAS-14FSXN	7.0	18.2	2 to 23	0.8
RAS-16FSXN	8.0	20.8	2 to 26	0.8
RAS-18FSXN	9.0	23.4	2 to 26	0.8
RAS-20FSXN	10.0	26.0	2 to 33	0.8
RAS-22FSXN	11.0	28.6	2 to 36	0.8
RAS-24FSXN	12.0	31.2	2 to 40	0.8
RAS-26FSXN	13.0	33.8	2 to 43	0.8
RAS-28FSXN	14.0	36.4	2 to 47	0.8
RAS-30FSXN	15.0	39.0	2 to 50	0.8
RAS-32FSXN	16.0	41.6	2 to 53	0.8
RAS-34FSXN	17.0	44.2	2 to 56	0.8
RAS-36FSXN	18.0	46.8	2 to 59	0.8
RAS-38FSXN	19.0	49.4	2 to 64	0.8
RAS-40FSXN	20.0	52.0	2 to 64	0.8
RAS-42FSXN	21.0	54.6	2 to 64	0.8
RAS-44FSXN	22.0	57.2	2 to 64	0.8
RAS-46FSXN	23.0	59.8	2 to 64	0.8
RAS-48FSXN	24.0	62.4	2 to 64	0.8
RAS-50FSXN	25.0	65.0	2 to 64	0.8
RAS-52FSXN	26.0	67.6	2 to 64	0.8
RAS-54FSXN	27.0	70.2	2 to 64	0.8

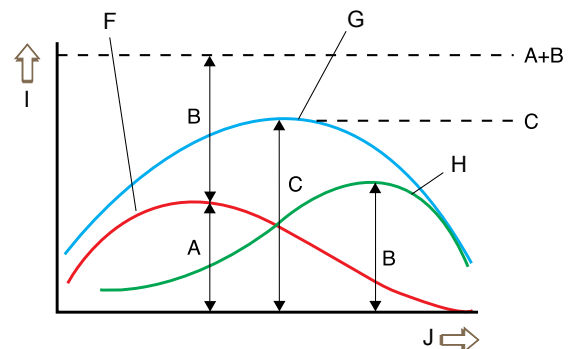
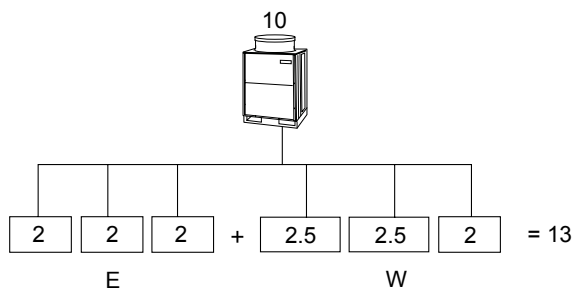
Connection capacity: from 50% to 130%.



### NOTE

- 1 For systems with all the indoor units operated simultaneously, the total capacity of the indoor units must be equal to or less than the capacity of the outdoor unit. Otherwise, it may perform poorly or have a narrow working range when overloaded.
- 2 For systems with indoor units not operated simultaneously, the total capacity of the indoor units is available up to 130% of the capacity of the outdoor unit.
- 3 If the system is used in cold areas (the ambient temperature reaches  $-10^{\circ}\text{C}$ ) or in warm areas, the total capacity of the indoor units must be less than 100% of the capacity of the outdoor unit and the refrigerant pipe length less than 300 m.
- 4 The indoor units of 0.4 and 1.0 HP are set for a greater air flow in comparison with the bigger units of 1.5 HP. Do not install these units in places where cold air currents can occur during the heating operation. Determine the application and installation environment carefully.

This concept allows the outdoor unit to have a 30% lower capacity compared to other air conditioning systems, in the case of combinations with a total power of 130%. This possibility is shown in the following example:



E: capacity of indoor units, eastern area (6 HP).

F: eastern area load.

G: total load.

H: western area load.

I: load.

J: time.

W: capacity of indoor units, western area (7 HP).



### NOTE

**All the numeric values indicate horse power (HP).**

The diagram represents installation in a typical building, with a peak morning heat load in the eastern area -A- equivalent to a unit of 6 HP. In the evening there is a heat load peak in the western area -B- equivalent to a unit of 7 HP. Therefore, a conventional system for the eastern and western areas (-A- + -B-) needs a total installation of 6 HP + 7 HP = 13 HP.

The maximum simultaneous load for the whole building -C- occurs at midday and is equivalent to a capacity of 10 HP. A SET FREE FSXN system with a capacity of 10 HP can be selected, which can be directed towards the east or west, depending on the system controls.



### NOTE

**The maximum loads required in the eastern and western area must not be simultaneous.**

The total combined power is calculated with the following formula:

$$\text{Total combined power} = (\text{Total power of the indoor units} / \text{Power of the outdoor unit}) \times 100$$

According to the data in the example:



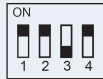

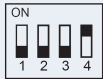


$$\text{Total combined power} = (13 \text{ HP} / 10 \text{ HP}) \times 100 = 130\%$$

### Power adjustment of indoor units using the DIP switch

In some situations, it is handy to be able to adjust the capacity of the indoor units to adapt them to actual installation requirements.

The power of each indoor unit in the SYSTEM FREE range can be precisely adjusted using a DIP switch located on the circuit board.

The DIP switch allows for more precise on-site adjustments to be made to the installation after mounting is complete, during start-up or at any time, optimising the total performance of the system.

Example of power adjustment on indoor units using the DIP switch									
Power (HP)	1.3			1.8			2.3		
Variable capacity	1.5		1.3	2.0	→	1.8	2.5	→	2.3
Application on models	RPI(M), RCI(M), RCD, RPK, RPF(I)			RPI, RCI, RCD, RPK, RPC			RPI, RCI, RCD, RPC		
Adjustment of DIP switch (DSW3)		→			→			→	
	Factory setting		Adjusted power	Factory setting		Adjusted power	Factory setting		Adjusted power



### NOTE

The nominal cooling and heating capacity is the combined capacity of the SET FREE system and is based on Standard EN14511.

Temperature conditions	Cooling	Heating
Inlet air temperature in the indoor heat exchanger	27 °C DB	20 °C DB
	19 °C WB	
Inlet air temperature in the outdoor heat exchanger	35 °C DB	7 °C DB
		6 °C WB

- Piping length: 7.5 m. Piping height: 0 m.
- DB: dry bulb; WB: wet bulb.



## 4.2 Selection procedure

To continue with the example proposed, we will assume the installation of a system made up of a variety of rooms with different cooling loads and temperature conditions required, which are shown below:

Temperature conditions	Cooling	Heating
Inlet air temperature in the indoor heat exchanger	27 °C DB	20 °C DB
	19 °C WB	
Inlet air temperature in the outdoor heat exchanger	30 °C DB	1 °C DB
		0 °C WB



### NOTE

**DB: dry bulb; WB: wet bulb.**

Total load for each room								
Concept			Room 1	Room 2	Room 3	Room 4	Room 5	Room 6
Estimated refrigerant charge	Total	(kW)	4.24	2.80	5.35	6.36	8.48	10.6
	Sensible	(kW)	3.09	2.00	3.90	4.64	6.19	7.73
Estimated heating load	Total	(kW)	4.77	3.10	6.00	7.16	9.54	11.9



### NOTE

- **In this example the maximum loads required shall not be simultaneous (-C- in the image in the previous chapter).**
- **The maximum loads required in rooms 1, 2 and 3 (eastern area) will occur in the morning.**
- **The maximum load required in rooms 4, 5 and 6 (western area) will occur in the afternoon.**

### Heat pump system (2 pipes)

- Equivalent piping length between outdoor unit and indoor units: 60 m.
- Piping height: -20 m.



### NOTE

**The outdoor unit has been deemed to be in a higher position than the indoor units. Therefore, when necessary, consult chapter [Correction factor depending on the pipe length](#), see on page 158, so you can use the adequate correction factor if the difference in height between the outdoor unit and the indoor unit is positive (+H).**

### Initial pre-selection

Taking into account the aforementioned possibilities of the SET FREE system, the capacities of the indoor units that needed it were adjusted using the DIP switch (DSW3).

Concept	Room 1	Room 2	Room 3	Room 4	Room 5	Room 6
Model selected	RPK-2.0 FSN(H)2M (set to 1.8)	RPIM-1.5 FSN2E(-DU) (set to 1.3)	RPI-2.0 FSN2E	RCD-2.5 FSN2 (set to 2.3)	RCI-4.0 FSN2E	RPI-5.0 FSN2E
Nominal refrigeration load (kW)	5.2	3.8	5.6	6.7	11.2	14.0
Nominal heating load (kW)	5.6	4.2	6.3	7.5	12.5	16.0

The pre-selected capacity of the different indoor units was not the one the immediately above so as to apply a safety factor, considering the different existing correction factors, which will lessen the capacity.



The maximum cooling capacity ( $Q_{MC}$ ) of the selected unit is **40.67 kW**.

**Calculation of  $f_{LC}$ :** both the length of the refrigerant pipe used and the difference in height between the outdoor unit and the indoor units directly affect unit output. This concept is quantified using the pipe length correction factor.

To determine this value see chapter [Correction factor depending on the pipe length](#), see on page 158, where you can see that for the characteristics of our example (pipe length of 50 m and difference in height between the outdoor unit and the indoor units of 20 m) the correction factor of the refrigerant pipe length for cooling mode is approximately **0.87**.

Once the applicable correction factors have been determined, the cooling capacity correction equation can be calculated:

$$Q_C = 40.67 \text{ kW} \times 0.87 = 35.38 \text{ kW}$$

#### Current cooling capacity of the outdoor unit

The cooling capacity data for the unit selected, obtained from the table in chapter [Nominal cooling capacity tables](#), see on page 71, is calculated based on a relative humidity of 50%, which means that an indoor air inlet temperature of 19 °C WB corresponds to a temperature of 27 °C DB.



#### NOTE

**DB: dry bulb; WB: wet bulb.**

Nevertheless, the difference between the dry bulb indoor air inlet temperature required by the system (28 °C) and the dry bulb air inlet temperature recorded in the cooling capacity data (27 °C) requires an adjustment of the capacity. The following equation was used to apply this adjustment.

$$Q_{AC} = Q_C + (CR \times (DB_R - DB))$$

$Q_{AC}$ : current cooling capacity of the outdoor unit (kW).

$Q_C$ : corrected cooling capacity of the outdoor unit (kW).

CR: correction rate due to humidity.

$DB_R$ : actual dry bulb temperature of the evaporator (°C).

DB: dry bulb temperature of the evaporator (°C) for each wet bulb temperature in the table (RH= 50%)

**Calculation of CR:** the correction rate due to humidity is obtained from the table in chapter [Nominal cooling capacity tables](#), see on page 71. This factor corrects the sensible heat capacity of the unit according to the relative humidity of the air entering the indoor unit. The greater the relative humidity, the lower the sensible heat capacity, and vice versa.

The correction rate (CR) for the unit selected is **0.74**.

Once the applicable correction factors have been determined, the current cooling capacity correction equation can be calculated for the outdoor unit:

$$Q_{AC} = 35.38 \text{ kW} + (0.74 \times (28 - 27)) = 36.52 \text{ kW}$$

#### Cooling capacity of each indoor unit

Once the current cooling capacity of the outdoor unit is known, the cooling capacity of each indoor unit must be calculated, according to the following equation:

$$Q_{CI} = Q_{AC} \times (Q_{NCI} / Q_{NCC})$$

$Q_{CI}$ : cooling capacity of each indoor unit.

$Q_{AC}$ : current cooling capacity of the outdoor unit (kW).

$Q_{NCI}$ : nominal cooling capacity of the indoor unit (kW).

$Q_{NCC}$ : nominal cooling capacity of the combination (kW).

RPK-2.0FSN(H)2M (set to 1.8)

$$36.52 \text{ kW} \times (1.49 \text{ kW} / (1.34 \text{ kW} + 0.97 \text{ kW} + 1.49 \text{ kW} + 1.72 \text{ HP} + 2.98 \text{ kW} + 3.73 \text{ kW})) = 4.44 \text{ kW}$$

RPIM-1.5FSN2E(-DU) (set to 1.3)

$$36.52 \text{ kW} \times (0.97 \text{ kW} / (1.34 \text{ kW} + 0.97 \text{ kW} + 1.49 \text{ kW} + 1.72 \text{ HP} + 2.98 \text{ kW} + 3.73 \text{ kW})) = 2.89 \text{ kW}$$

RPI-2.0FSN2E

$$36.52 \text{ kW} \times (1.49 \text{ kW} / (1.34 \text{ kW} + 0.97 \text{ kW} + 1.49 \text{ kW} + 1.72 \text{ HP} + 2.98 \text{ kW} + 3.73 \text{ kW})) = 4.44 \text{ kW}$$

RCD-2.5FSN2 (set to 2.3)

$$36.52 \text{ kW} \times (1.86 \text{ kW} / (1.34 \text{ kW} + 0.97 \text{ kW} + 1.49 \text{ kW} + 1.72 \text{ HP} + 2.98 \text{ kW} + 3.73 \text{ kW})) = 5.55 \text{ kW}$$

RCI-4.0FSN2E

 $36.52 \text{ kW} \times (2.98 \text{ kW} / (1.34 \text{ kW} + 0.97 \text{ kW} + 1.49 \text{ kW} + 1.72 \text{ HP} + 2.98 \text{ kW} + 3.73 \text{ kW})) = 8.89 \text{ kW}$ 

RPI-5.0FSN2E

 $36.52 \text{ kW} \times (3.73 \text{ kW} / (1.34 \text{ kW} + 0.97 \text{ kW} + 1.49 \text{ kW} + 1.72 \text{ HP} + 2.98 \text{ kW} + 3.73 \text{ kW})) = 11.13 \text{ kW}$ 

### Sensible heat capacity (SHC)

The requirements of the system specify a sensible heat load for each indoor unit. Once the cooling capacity of the indoor units has been calculated, the sensible heat capacity can be calculated using the following equation:

$$SHC = Q_{CI} \times SHF$$

SHC: sensible heat capacity (kW).

Q<sub>CI</sub>: cooling capacity of each indoor unit.

SHF: sensible heat factor.

**Calculation of SHF:** To determine the sensible heat factor SHF (sensible heat index in relation to the total), consult the table in chapter *Sensible heat factor (SHF)*, see on page 163, which shows the different values for the different indoor units at each of the three possible fan speeds (high, medium and low). The value used is the one corresponding to the high fan speed.

Consulting the table we obtain the following values:

 $SHF_{RPK-2.0FSN(H)2M \text{ (set to 1.8)}} = 0.72$ 
 $SHF_{RPIM-1.5FSN2E(-DU) \text{ (set to 1.3)}} = 0.71$ 
 $SHF_{RPI-2.0FSN2E} = 0.76$ 
 $SHF_{RCD-2.5FSN2 \text{ (set to 2.3)}} = 0.75$ 
 $SHF_{RCI-4.0FSN2E} = 0.78$ 
 $SHF_{RPI-5.0FSN2E} = 0.72$ 

Once the applicable values have been determined, the sensible heat capacity (SHC) equation can be calculated:

 $SHC_{RPK-2.0FSN(H)2M \text{ (set to 1.8)}} = 4.44 \times 0.72 = 3.19 \text{ kW}$ 
 $SHC_{RPIM-1.5FSN2E(-DU) \text{ (set to 1.3)}} = 2.89 \times 0.71 = 2.05 \text{ kW}$ 
 $SHC_{RPI-2.0FSN2E} = 4.44 \times 0.76 = 3.37 \text{ kW}$ 
 $SHC_{RCD-2.5FSN2 \text{ (set to 2.3)}} = 5.55 \times 0.75 = 4.16 \text{ kW}$ 
 $SHC_{RCI-4.0FSN2E} = 8.89 \times 0.78 = 6.93 \text{ kW}$ 
 $SHC_{RPI-5.0FSN2E} = 11.13 \times 0.72 = 8.01 \text{ kW}$ 

The cooling mode results are the following:

			Total load for each room					
Concept			Room 1	Room 2	Room 3	Room 4	Room 5	Room 6
Model selected			RPK-2.0 FSN(H)2M (set to 1.8)	RPIM-1.5 FSN2E(-DU) (set to 1.3)	RPI-2.0 FSN2E	RCD-2.5 FSN2 (set to 2.3)	RCI-4.0 FSN2E	RPI-5.0 FSN2E
Estimated cooling load	Total	(kW)	4.24	2.80	5.35	6.36	8.48	10.6
	Sensible	(kW)	3.09	2.00	3.90	4.64	6.19	7.73
Corrected cooling load	Total	(kW)	4.44	2.89	4.44	5.55	8.89	11.13
	Sensible	(kW)	3.24	2.10	3.24	4.05	6.48	8.12

As you can see, the values of the total and sensible corrected cooling capacity are greater than the value of the estimated cooling load for the different rooms. Therefore, the pre-selected outdoor unit can be seen to meet the minimum cooling requirements established for the system.



### NOTE

**Where the actual cooling capacity calculated (total or sensible) is lower than that supplied by the pre-selected unit, the calculation must be made once again using the immediately superior unit.**

## 4.2.2 Heating mode

Consulting the initial pre-selection section in chapter [Selection procedure](#), see on page 65, where you can see the nominal heating capacities selected for each room and the capacity of the outdoor unit at a total combined power of 110%, it is obtained that the total power of the indoor units is 48.6 HP.

Concept	Room 1	Room 2	Room 3	Room 4	Room 5	Room 6
Model selected	RPK-2.0 FSN(H)2M (set to 1.8)	RPIM-1.5 FSN2E(-DU) (set to 1.3)	RPI-2.0 FSN2E	RCD-2.5 FSN2 (set to 2.3)	RCI-4.0 FSN2E	RPI-5.0 FSN2E
Nominal heating load (kW)	6.3	4.8	6.3	8.5	12.5	16

### Heating capacity correction

The actual heating capacity of the pre-selected outdoor unit must be calculated applying the following equation with the necessary correction factors:

$$Q^H = Q_{MH} \times f_{LC} \times f_D$$

$Q_H$ : corrected heating capacity of the outdoor unit (kW)

$Q_{MH}$ : nominal heating capacity of the outdoor unit (kW)

$f_{LH}$ : refrigerant pipe length correction factor.

$f_D$ : defrost correction factor.

The maximum heating capacity ( $Q_{MH}$ ) of the selected unit is **44.67 kW**.

**Calculation of  $f_{LH}$ :** both the length of the refrigerant pipe used and the difference in height between the outdoor unit and the indoor units directly affect unit output. This concept is quantified using the pipe length correction factor.

To determine this value see chapter [Correction factor depending on the pipe length](#), see on page 158, where you can see that for the characteristics of our example (pipe length of 50 m and difference in height between the outdoor unit and the indoor units of 20 m) the correction factor of the refrigerant pipe length for heating mode is approximately **0.93**.

**Calculation of  $f_D$ :** in situations where the ambient temperature is lower than 7 °C DB, frost may occur in the heat exchanger. In this case, the heating capacity of the unit decreases due to the time it needs to remove the accumulation of ice.

The defrost correction factor considers this time and corrects the heating capacity. To calculate the correction factor, consult chapter [Correction factor depending on defrost](#), see on page 162, which shows a table with different values for  $f_D$  according to the ambient temperature (°C DB). If the correction factor for a certain ambient temperature, for example 5 °C DB, does not appear in the table, carry out an interpolation between the immediately higher and lower values.

For the current example, the resulting defrost correction factor is **0.90**.



### NOTE

**DB: dry bulb; WB: wet bulb.**

Once the applicable correction factors have been determined, the heating capacity correction equation can be calculated:

$$Q_C = 44.67 \text{ kW} \times 0.93 \times 0.90 = 37.38 \text{ kW}$$

### Heating capacity of each indoor unit

Once the current heating capacity of the outdoor unit is known, the heating capacity of each indoor unit must be calculated, according to the following equation:

$$Q_{HI} = Q_{AH} \times (Q_{NHI} / Q_{NHC})$$

$Q_{HI}$ : heating capacity of each indoor unit.

$Q_{AH}$ : current heating capacity of the outdoor unit (kW)

$Q_{NHI}$ : nominal heating capacity of the indoor unit (kW).

$Q_{NHC}$ : nominal heating capacity of the combination (kW).

RPK-2.0FSN(H)2M (set to 1.8)

$$37.38 \text{ kW} \times (4.18 \text{ kW} / (4.18 \text{ kW} + 3.13 \text{ kW} + 4.7 \text{ kW} + 5.59 \text{ kW} + 9.32 \text{ kW} + 11.93 \text{ kW})) = 4.02 \text{ kW}$$

RPIM-1.5FSN2E(-DU) (set to 1.3)

$$37.38 \text{ kW} \times (3.13 \text{ kW} / (4.18 \text{ kW} + 3.13 \text{ kW} + 4.7 \text{ kW} + 5.59 \text{ kW} + 9.32 \text{ kW} + 11.93 \text{ kW})) = 3.01 \text{ kW}$$

RPI-2.0FSN2E

 $37.38 \text{ kW} \times (4.7 \text{ kW} / (4.18 \text{ kW} + 3.13 \text{ kW} + 4.7 \text{ kW} + 5.59 \text{ kW} + 9.32 \text{ kW} + 11.93 \text{ kW})) = 4.52 \text{ kW}.$ 

RCD-2.5FSN2 (set to 2.3)

 $37.38 \text{ kW} \times (5.59 \text{ kW} / (4.18 \text{ kW} + 3.13 \text{ kW} + 4.7 \text{ kW} + 5.59 \text{ kW} + 9.32 \text{ kW} + 11.93 \text{ kW})) = 5.37 \text{ kW}.$ 

RCI-4.0FSN2E

 $37.38 \text{ kW} \times (9.32 \text{ kW} / (4.18 \text{ kW} + 3.13 \text{ kW} + 4.7 \text{ kW} + 5.59 \text{ kW} + 9.32 \text{ kW} + 11.93 \text{ kW})) = 8.96 \text{ kW}.$ 

RPI-5.0FSN2E

 $37.38 \text{ kW} \times (11.93 \text{ kW} / (4.18 \text{ kW} + 3.13 \text{ kW} + 4.7 \text{ kW} + 5.59 \text{ kW} + 9.32 \text{ kW} + 11.93 \text{ kW})) = 11.47 \text{ kW}.$ 

The heating mode results are the following:

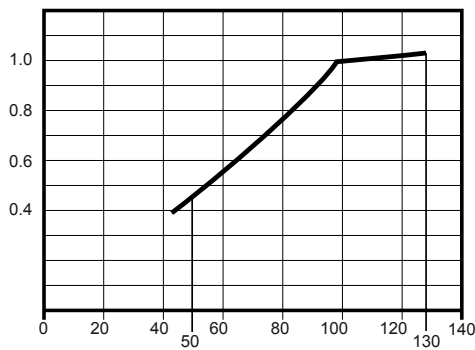
Total load for each room								
Concept			Room 1	Room 2	Room 3	Room 4	Room 5	Room 6
Model selected			RPK-2.0 FSN(H)2M (set to 1.8)	RPIM-1.5 FSN2E(-DU) (set to 1.3)	RPI-2.0 FSN2E	RCD-2.5 FSN2 (set to 2.3)	RCI-4.0 FSN2E	RPI-5.0 FSN2E
Estimated heating load	Total	(kW)	4.24	2.80	5.35	6.36	8.48	10.6
Corrected heating load	Total	(kW)	4.02	3.01	4.52	5.37	8.96	11.47

As you can see, the values of the total corrected heating capacity are greater than the value of the estimated heating load for the different rooms. Therefore, the outdoor unit can be seen to meet the minimum heating requirements established for the system.


**NOTE**

**Where the actual heating capacity calculated is lower than that supplied by the selected unit, the calculation must be made once again using the immediately superior unit.**

### 4.3 Nominal cooling capacity tables



The following charts and tables show the characteristics of outdoor unit capacity in cooling mode which corresponds with total horsepower of combined indoor unit, on standard condition with refrigerant piping of horizontal and 7.5m at length.

Indoor Air Inlet Temperature:	27.0°C DB (80.0°F DB)	19.0°C WB (66.2°F WB)
Outdoor Air Inlet Temperature:	35.0°C DB (95.0°F DB)	-

DB: Dry bulb

WB: Wet bulb

#### RAS-8FSXN

To\Ti	14		16		18		19		20		22		23		24	
	Q	P	Q	P	Q	P	Q	P	Q	P	Q	P	Q	P	Q	P
10	0,81	0,78	0,86	0,79	0,96	0,85	1,00	0,87	1,05	0,88	1,10	0,90	1,12	0,90	1,15	0,91
12	0,81	0,78	0,86	0,79	0,96	0,85	1,00	0,87	1,05	0,88	1,10	0,90	1,12	0,90	1,15	0,91
14	0,81	0,78	0,86	0,79	0,96	0,85	1,00	0,87	1,04	0,89	1,10	0,90	1,12	0,90	1,15	0,91
16	0,81	0,79	0,86	0,80	0,96	0,86	1,00	0,88	1,04	0,89	1,10	0,90	1,12	0,91	1,15	0,91
18	0,81	0,79	0,86	0,80	0,95	0,86	1,00	0,88	1,04	0,90	1,10	0,91	1,12	0,92	1,15	0,92
20	0,81	0,80	0,86	0,81	0,96	0,87	1,00	0,89	1,04	0,91	1,10	0,92	1,12	0,92	1,14	0,93
22	0,81	0,81	0,86	0,82	0,96	0,88	1,00	0,90	1,04	0,91	1,10	0,93	1,12	0,93	1,14	0,94
24	0,81	0,82	0,86	0,83	0,96	0,89	1,00	0,91	1,04	0,93	1,10	0,94	1,12	0,95	1,14	0,95
25	0,80	0,82	0,86	0,84	0,96	0,90	1,00	0,92	1,04	0,94	1,10	0,95	1,12	0,96	1,14	0,96
26	0,80	0,83	0,86	0,84	0,96	0,90	1,00	0,92	1,04	0,94	1,10	0,95	1,12	0,96	1,14	0,96
28	0,80	0,84	0,86	0,85	0,96	0,91	1,00	0,93	1,04	0,95	1,10	0,96	1,12	0,97	1,14	0,97
30	0,80	0,85	0,86	0,86	0,96	0,92	1,00	0,94	1,04	0,96	1,10	0,97	1,12	0,98	1,14	0,98
32	0,80	0,87	0,86	0,88	0,96	0,94	1,00	0,96	1,04	0,98	1,10	0,99	1,12	1,00	1,14	1,00
34	0,80	0,89	0,86	0,91	0,96	0,97	1,00	0,99	1,04	1,00	1,10	1,02	1,12	1,02	1,14	1,03
35	0,80	0,90	0,86	0,92	0,96	0,98	1,00	1,00	1,04	1,02	1,10	1,03	1,12	1,04	1,14	1,04
36	0,80	0,93	0,86	0,95	0,95	1,01	0,99	1,03	1,03	1,04	1,09	1,06	1,11	1,06	1,13	1,07
38	0,79	0,98	0,85	1,00	0,94	1,06	0,98	1,08	1,01	1,09	1,06	1,11	1,08	1,12	1,10	1,12
40	0,79	1,03	0,85	1,05	0,92	1,11	0,96	1,13	1,00	1,15	1,04	1,17	1,05	1,17	1,07	1,18



**RAS-10FSXN**

To\Ti	14		16		18		19		20		22		23		24	
	Q	P	Q	P	Q	P	Q	P	Q	P	Q	P	Q	P	Q	P
10	0,81	0,75	0,86	0,76	0,95	0,81	1,00	0,82	1,05	0,84	1,10	0,85	1,13	0,86	1,15	0,86
12	0,81	0,75	0,86	0,76	0,95	0,81	1,00	0,83	1,04	0,84	1,10	0,85	1,12	0,86	1,15	0,86
14	0,81	0,75	0,86	0,77	0,95	0,81	1,00	0,83	1,04	0,84	1,10	0,85	1,12	0,86	1,15	0,86
16	0,81	0,76	0,86	0,77	0,95	0,81	1,00	0,83	1,04	0,84	1,10	0,86	1,12	0,86	1,15	0,87
18	0,81	0,76	0,86	0,78	0,95	0,82	1,00	0,84	1,04	0,85	1,10	0,87	1,12	0,87	1,15	0,87
20	0,81	0,77	0,86	0,78	0,95	0,83	1,00	0,85	1,04	0,86	1,10	0,87	1,12	0,88	1,14	0,88
22	0,81	0,78	0,86	0,79	0,95	0,84	1,00	0,85	1,04	0,87	1,10	0,88	1,12	0,89	1,14	0,89
24	0,81	0,79	0,86	0,80	0,95	0,85	1,00	0,87	1,04	0,88	1,10	0,89	1,12	0,90	1,14	0,90
25	0,81	0,79	0,86	0,81	0,95	0,85	1,00	0,87	1,04	0,89	1,10	0,90	1,12	0,91	1,14	0,91
26	0,81	0,80	0,86	0,82	0,95	0,86	1,00	0,88	1,04	0,89	1,10	0,91	1,12	0,91	1,14	0,92
28	0,81	0,81	0,86	0,83	0,95	0,87	1,00	0,89	1,04	0,90	1,10	0,92	1,12	0,93	1,14	0,93
30	0,81	0,83	0,86	0,84	0,95	0,89	1,00	0,90	1,04	0,92	1,10	0,93	1,12	0,94	1,14	0,95
32	0,81	0,86	0,86	0,88	0,95	0,92	1,00	0,94	1,04	0,96	1,10	0,97	1,12	0,98	1,14	0,98
34	0,81	0,90	0,86	0,92	0,95	0,96	1,00	0,98	1,04	1,00	1,10	1,01	1,12	1,02	1,14	1,02
35	0,81	0,92	0,86	0,94	0,95	0,98	1,00	1,00	1,04	1,02	1,10	1,03	1,12	1,03	1,14	1,04
36	0,80	0,95	0,86	0,96	0,95	1,01	0,99	1,02	1,03	1,04	1,08	1,05	1,10	1,06	1,12	1,06
38	0,79	0,99	0,85	1,01	0,93	1,05	0,97	1,07	1,01	1,08	1,05	1,10	1,07	1,11	1,09	1,11
40	0,78	1,04	0,84	1,06	0,91	1,10	0,95	1,12	0,98	1,13	1,02	1,15	1,04	1,15	1,05	1,16



**RAS-12FSXN**

To\Ti	14		16		18		19		20		22		23		24	
	Q	P	Q	P	Q	P	Q	P	Q	P	Q	P	Q	P	Q	P
10	0,81	0,74	0,86	0,75	0,96	0,78	1,00	0,79	1,05	0,81	1,10	0,82	1,12	0,82	1,15	0,83
12	0,81	0,74	0,86	0,75	0,96	0,78	1,00	0,80	1,04	0,81	1,10	0,82	1,12	0,82	1,15	0,83
14	0,81	0,74	0,86	0,76	0,96	0,79	1,00	0,80	1,04	0,81	1,10	0,82	1,12	0,83	1,15	0,83
16	0,81	0,75	0,86	0,76	0,96	0,79	1,00	0,80	1,04	0,81	1,10	0,83	1,12	0,83	1,15	0,84
18	0,81	0,75	0,86	0,77	0,96	0,80	1,00	0,81	1,04	0,82	1,10	0,83	1,12	0,84	1,15	0,84
20	0,81	0,76	0,86	0,77	0,96	0,81	1,00	0,82	1,04	0,83	1,10	0,84	1,12	0,85	1,14	0,85
22	0,81	0,77	0,86	0,78	0,96	0,81	1,00	0,82	1,04	0,84	1,10	0,85	1,12	0,86	1,14	0,86
24	0,81	0,78	0,86	0,79	0,96	0,83	1,00	0,84	1,04	0,85	1,10	0,86	1,12	0,87	1,14	0,87
25	0,81	0,79	0,86	0,80	0,96	0,83	1,00	0,84	1,04	0,86	1,10	0,87	1,12	0,87	1,14	0,88
26	0,81	0,80	0,86	0,81	0,96	0,84	1,00	0,86	1,04	0,87	1,10	0,88	1,12	0,89	1,14	0,89
28	0,80	0,82	0,86	0,84	0,96	0,87	1,00	0,88	1,04	0,89	1,10	0,91	1,12	0,91	1,14	0,92
30	0,80	0,85	0,86	0,86	0,96	0,89	1,00	0,90	1,04	0,91	1,10	0,93	1,12	0,93	1,14	0,94
32	0,80	0,88	0,86	0,90	0,96	0,93	1,00	0,94	1,04	0,95	1,09	0,97	1,11	0,97	1,13	0,98
34	0,80	0,92	0,86	0,93	0,96	0,97	1,00	0,98	1,04	0,99	1,09	1,01	1,10	1,01	1,12	1,02
35	0,80	0,94	0,86	0,95	0,96	0,99	1,00	1,00	1,04	1,01	1,08	1,03	1,10	1,03	1,11	1,04
36	0,80	0,96	0,86	0,98	0,95	1,01	0,99	1,02	1,02	1,03	1,06	1,05	1,08	1,05	1,09	1,05
38	0,79	1,02	0,84	1,04	0,92	1,06	0,96	1,07	0,99	1,08	1,02	1,08	1,03	1,08	1,04	1,09
40	0,77	1,07	0,83	1,09	0,90	1,11	0,93	1,12	0,96	1,12	0,98	1,12	0,99	1,12	1,00	1,12

**RAS-14FSXN**

To\Ti	14		16		18		19		20		22		23		24	
	Q	P	Q	P	Q	P	Q	P	Q	P	Q	P	Q	P	Q	P
10	0,81	0,74	0,86	0,75	0,96	0,78	1,00	0,80	1,05	0,80	1,10	0,82	1,12	0,83	1,15	0,83
12	0,81	0,74	0,86	0,75	0,96	0,78	1,00	0,80	1,05	0,81	1,10	0,82	1,12	0,83	1,15	0,83
14	0,81	0,74	0,86	0,76	0,96	0,79	1,00	0,80	1,04	0,81	1,10	0,82	1,12	0,83	1,15	0,83
16	0,81	0,75	0,86	0,76	0,96	0,79	1,00	0,81	1,04	0,81	1,10	0,83	1,12	0,83	1,15	0,83
18	0,81	0,75	0,86	0,77	0,96	0,79	1,00	0,81	1,04	0,82	1,10	0,83	1,12	0,84	1,15	0,84
20	0,81	0,76	0,86	0,77	0,96	0,80	1,00	0,82	1,04	0,83	1,10	0,84	1,12	0,85	1,14	0,85
22	0,81	0,77	0,86	0,78	0,96	0,81	1,00	0,83	1,04	0,84	1,10	0,85	1,12	0,86	1,14	0,86
24	0,81	0,78	0,86	0,79	0,96	0,82	1,00	0,84	1,04	0,85	1,10	0,86	1,12	0,87	1,14	0,87
25	0,81	0,79	0,86	0,80	0,96	0,83	1,00	0,85	1,04	0,85	1,10	0,87	1,12	0,88	1,14	0,88
26	0,81	0,80	0,86	0,81	0,96	0,84	1,00	0,86	1,04	0,87	1,10	0,88	1,12	0,89	1,14	0,89
28	0,80	0,82	0,86	0,84	0,96	0,87	1,00	0,88	1,04	0,89	1,10	0,91	1,12	0,91	1,14	0,91
30	0,80	0,85	0,86	0,86	0,96	0,89	1,00	0,91	1,04	0,92	1,10	0,93	1,12	0,94	1,14	0,94
32	0,80	0,88	0,86	0,90	0,96	0,93	1,00	0,94	1,04	0,95	1,09	0,97	1,11	0,98	1,13	0,98
34	0,80	0,92	0,86	0,94	0,96	0,97	1,00	0,98	1,04	0,99	1,09	1,00	1,10	1,01	1,12	1,02
35	0,80	0,94	0,86	0,95	0,96	0,99	1,00	1,00	1,04	1,01	1,09	1,02	1,10	1,03	1,11	1,04
36	0,80	0,96	0,86	0,98	0,95	1,02	0,99	1,02	1,02	1,03	1,06	1,04	1,08	1,05	1,09	1,06
38	0,79	1,02	0,84	1,04	0,93	1,07	0,96	1,07	0,99	1,08	1,02	1,08	1,03	1,09	1,04	1,09
40	0,77	1,07	0,83	1,09	0,91	1,12	0,93	1,12	0,96	1,12	0,98	1,12	0,99	1,12	1,00	1,12

**RAS-16FSXN**

To\Ti	14		16		18		19		20		22		23		24	
	Q	P	Q	P	Q	P	Q	P	Q	P	Q	P	Q	P	Q	P
10	0,81	0,74	0,86	0,76	0,96	0,78	1,00	0,79	1,05	0,81	1,10	0,82	1,12	0,83	1,15	0,83
12	0,81	0,74	0,86	0,76	0,96	0,78	1,00	0,80	1,05	0,81	1,10	0,82	1,12	0,83	1,15	0,83
14	0,81	0,75	0,86	0,76	0,96	0,78	1,00	0,80	1,04	0,81	1,10	0,82	1,12	0,83	1,15	0,83
16	0,81	0,75	0,86	0,76	0,96	0,79	1,00	0,80	1,04	0,82	1,10	0,83	1,12	0,83	1,15	0,83
18	0,81	0,75	0,86	0,77	0,96	0,79	1,00	0,81	1,04	0,82	1,10	0,84	1,12	0,84	1,15	0,84
20	0,81	0,76	0,86	0,78	0,96	0,80	1,00	0,82	1,04	0,83	1,10	0,84	1,12	0,85	1,14	0,85
22	0,81	0,77	0,86	0,79	0,96	0,81	1,00	0,82	1,04	0,84	1,10	0,85	1,12	0,86	1,14	0,86
24	0,81	0,78	0,86	0,80	0,96	0,82	1,00	0,84	1,04	0,85	1,10	0,86	1,12	0,87	1,14	0,87
25	0,81	0,79	0,86	0,80	0,96	0,83	1,00	0,84	1,04	0,86	1,10	0,87	1,12	0,88	1,14	0,88
26	0,81	0,80	0,86	0,81	0,96	0,84	1,00	0,86	1,04	0,87	1,10	0,88	1,12	0,89	1,14	0,89
28	0,80	0,82	0,86	0,84	0,96	0,87	1,00	0,88	1,04	0,89	1,10	0,91	1,12	0,91	1,14	0,91
30	0,80	0,84	0,86	0,86	0,96	0,89	1,00	0,90	1,04	0,92	1,10	0,93	1,12	0,93	1,14	0,94
32	0,80	0,88	0,86	0,90	0,96	0,93	1,00	0,94	1,04	0,95	1,08	0,97	1,10	0,97	1,12	0,97
34	0,80	0,93	0,86	0,94	0,96	0,97	1,00	0,98	1,03	0,99	1,07	1,01	1,09	1,01	1,10	1,01
35	0,80	0,95	0,86	0,97	0,96	0,99	1,00	1,00	1,03	1,01	1,07	1,03	1,08	1,03	1,09	1,03
36	0,80	0,97	0,85	0,99	0,94	1,01	0,98	1,02	1,01	1,02	1,04	1,04	1,05	1,04	1,06	1,04
38	0,78	1,02	0,84	1,04	0,91	1,05	0,95	1,05	0,97	1,06	0,99	1,06	1,00	1,06	1,01	1,06
40	0,76	1,07	0,82	1,09	0,89	1,09	0,91	1,09	0,92	1,09	0,94	1,09	0,94	1,09	0,95	1,09

**RAS-18FSXN**

To\Ti	14		16		18		19		20		22		23		24	
	Q	P	Q	P	Q	P	Q	P	Q	P	Q	P	Q	P	Q	P
10	0,81	0,74	0,86	0,76	0,96	0,78	1,00	0,80	1,05	0,81	1,10	0,82	1,12	0,82	1,15	0,83
12	0,81	0,74	0,86	0,76	0,96	0,78	1,00	0,80	1,05	0,81	1,10	0,82	1,12	0,82	1,15	0,83
14	0,81	0,75	0,86	0,76	0,96	0,79	1,00	0,80	1,04	0,81	1,10	0,82	1,12	0,83	1,15	0,83
16	0,81	0,75	0,86	0,76	0,96	0,79	1,00	0,80	1,04	0,82	1,10	0,82	1,12	0,83	1,15	0,84
18	0,81	0,75	0,86	0,77	0,96	0,80	1,00	0,81	1,04	0,82	1,10	0,83	1,12	0,84	1,15	0,84
20	0,81	0,76	0,87	0,78	0,96	0,81	1,00	0,82	1,04	0,83	1,10	0,84	1,12	0,85	1,15	0,85
22	0,81	0,77	0,87	0,79	0,96	0,81	1,00	0,83	1,04	0,84	1,10	0,85	1,12	0,86	1,15	0,86
24	0,81	0,78	0,87	0,80	0,96	0,83	1,00	0,84	1,04	0,85	1,10	0,86	1,12	0,87	1,15	0,87
25	0,81	0,79	0,86	0,80	0,96	0,83	1,00	0,84	1,04	0,86	1,10	0,87	1,12	0,87	1,14	0,88
26	0,81	0,80	0,86	0,81	0,96	0,84	1,00	0,86	1,04	0,87	1,10	0,88	1,12	0,89	1,14	0,89
28	0,81	0,82	0,86	0,84	0,96	0,87	1,00	0,88	1,04	0,89	1,10	0,90	1,12	0,91	1,14	0,92
30	0,81	0,85	0,86	0,86	0,96	0,89	1,00	0,90	1,04	0,92	1,10	0,93	1,12	0,93	1,14	0,94
32	0,80	0,89	0,86	0,90	0,96	0,93	1,00	0,94	1,04	0,95	1,08	0,97	1,10	0,97	1,12	0,97
34	0,81	0,93	0,86	0,94	0,96	0,97	1,00	0,98	1,03	0,99	1,07	1,00	1,09	1,01	1,10	1,01
35	0,81	0,95	0,86	0,96	0,96	0,99	1,00	1,00	1,03	1,01	1,07	1,02	1,08	1,02	1,09	1,02
36	0,80	0,97	0,86	0,99	0,94	1,01	0,98	1,02	1,01	1,02	1,04	1,04	1,05	1,04	1,06	1,04
38	0,78	1,02	0,84	1,04	0,91	1,05	0,95	1,05	0,97	1,06	0,99	1,06	1,00	1,06	1,01	1,06
40	0,76	1,07	0,82	1,09	0,89	1,09	0,91	1,09	0,92	1,09	0,94	1,09	0,95	1,09	0,95	1,09

**RAS-20FSXN**

To\Ti	14		16		18		19		20		22		23		24	
	Q	P	Q	P	Q	P	Q	P	Q	P	Q	P	Q	P	Q	P
10	0,81	0,75	0,86	0,77	0,95	0,81	1,00	0,82	1,04	0,84	1,10	0,85	1,12	0,85	1,15	0,86
12	0,81	0,75	0,86	0,77	0,95	0,81	1,00	0,83	1,04	0,84	1,10	0,85	1,12	0,85	1,15	0,86
14	0,81	0,76	0,86	0,77	0,95	0,81	1,00	0,83	1,04	0,84	1,10	0,85	1,12	0,85	1,15	0,86
16	0,81	0,76	0,86	0,77	0,95	0,82	1,00	0,83	1,04	0,84	1,10	0,85	1,12	0,86	1,15	0,87
18	0,81	0,77	0,86	0,78	0,95	0,82	1,00	0,84	1,04	0,85	1,10	0,86	1,12	0,87	1,15	0,87
20	0,81	0,77	0,86	0,79	0,95	0,83	1,00	0,85	1,04	0,86	1,10	0,87	1,12	0,87	1,14	0,88
22	0,81	0,78	0,86	0,80	0,95	0,84	1,00	0,85	1,04	0,87	1,09	0,88	1,12	0,89	1,14	0,89
24	0,81	0,79	0,86	0,81	0,95	0,85	1,00	0,87	1,04	0,88	1,09	0,89	1,12	0,90	1,14	0,90
25	0,80	0,80	0,86	0,81	0,95	0,86	1,00	0,87	1,04	0,89	1,09	0,90	1,12	0,90	1,14	0,91
26	0,80	0,81	0,86	0,82	0,95	0,87	1,00	0,88	1,04	0,89	1,09	0,91	1,12	0,91	1,14	0,92
28	0,80	0,83	0,86	0,84	0,95	0,89	1,00	0,90	1,04	0,91	1,09	0,93	1,12	0,93	1,14	0,94
30	0,80	0,85	0,86	0,86	0,95	0,90	1,00	0,92	1,04	0,93	1,09	0,95	1,12	0,95	1,14	0,95
32	0,80	0,88	0,86	0,89	0,95	0,94	1,00	0,95	1,04	0,96	1,09	0,98	1,11	0,99	1,13	0,99
34	0,80	0,91	0,86	0,92	0,95	0,97	1,00	0,98	1,04	1,00	1,09	1,01	1,11	1,02	1,13	1,02
35	0,80	0,92	0,86	0,94	0,95	0,99	1,00	1,00	1,04	1,01	1,09	1,02	1,11	1,04	1,12	1,04
36	0,80	0,95	0,86	0,97	0,95	1,01	0,99	1,03	1,02	1,04	1,07	1,05	1,09	1,06	1,10	1,06
38	0,79	1,00	0,85	1,02	0,93	1,06	0,96	1,08	1,00	1,08	1,04	1,09	1,05	1,10	1,06	1,10
40	0,78	1,06	0,84	1,08	0,91	1,11	0,94	1,13	0,97	1,13	1,00	1,14	1,02	1,14	1,03	1,14

4

**RAS-22FSXN**

To\Ti	14		16		18		19		20		22		23		24	
	Q	P	Q	P	Q	P	Q	P	Q	P	Q	P	Q	P	Q	P
10	0,81	0,76	0,87	0,78	0,96	0,82	1,00	0,83	1,05	0,84	1,11	0,86	1,14	0,87	1,16	0,87
12	0,81	0,76	0,87	0,78	0,96	0,82	1,00	0,83	1,05	0,84	1,11	0,86	1,13	0,87	1,16	0,87
14	0,81	0,77	0,87	0,78	0,96	0,82	1,00	0,83	1,05	0,85	1,11	0,86	1,13	0,87	1,16	0,87
16	0,81	0,77	0,87	0,78	0,96	0,82	1,00	0,84	1,05	0,85	1,11	0,87	1,13	0,87	1,16	0,88
18	0,81	0,77	0,87	0,79	0,96	0,83	1,00	0,85	1,05	0,86	1,11	0,88	1,13	0,88	1,16	0,89
20	0,81	0,78	0,87	0,80	0,96	0,84	1,00	0,85	1,05	0,86	1,11	0,88	1,13	0,89	1,16	0,89
22	0,81	0,79	0,87	0,81	0,96	0,85	1,00	0,86	1,05	0,87	1,11	0,89	1,13	0,90	1,16	0,91
24	0,81	0,80	0,87	0,82	0,96	0,86	1,00	0,87	1,05	0,89	1,11	0,91	1,13	0,91	1,16	0,92
25	0,81	0,81	0,87	0,82	0,96	0,87	1,00	0,88	1,04	0,89	1,11	0,91	1,13	0,92	1,15	0,92
26	0,81	0,82	0,87	0,83	0,96	0,87	1,00	0,89	1,04	0,90	1,11	0,92	1,13	0,93	1,15	0,93
28	0,81	0,84	0,87	0,85	0,96	0,89	1,00	0,91	1,04	0,92	1,11	0,94	1,13	0,95	1,15	0,95
30	0,81	0,86	0,87	0,87	0,96	0,91	1,00	0,92	1,04	0,94	1,11	0,96	1,13	0,97	1,15	0,97
32	0,81	0,89	0,87	0,90	0,96	0,94	1,00	0,95	1,04	0,97	1,11	1,00	1,13	1,00	1,15	1,01
34	0,81	0,92	0,87	0,94	0,96	0,97	1,00	0,98	1,04	1,00	1,11	1,03	1,12	1,04	1,14	1,05
35	0,81	0,93	0,87	0,95	0,96	0,99	1,00	1,00	1,04	1,02	1,11	1,05	1,12	1,05	1,14	1,06
36	0,80	0,96	0,86	0,98	0,95	1,02	0,99	1,03	1,03	1,04	1,09	1,07	1,10	1,08	1,12	1,08
38	0,80	1,02	0,86	1,04	0,94	1,08	0,97	1,09	1,01	1,10	1,05	1,12	1,07	1,12	1,08	1,12
40	0,79	1,08	0,85	1,10	0,93	1,13	0,95	1,15	0,98	1,15	1,02	1,16	1,03	1,16	1,04	1,16

**RAS-24FSXN**

To\Ti	14		16		18		19		20		22		23		24	
	Q	P	Q	P	Q	P	Q	P	Q	P	Q	P	Q	P	Q	P
10	0,80	0,73	0,85	0,75	0,95	0,78	1,00	0,80	1,04	0,81	1,09	0,82	1,11	0,82	1,14	0,83
12	0,80	0,73	0,85	0,75	0,95	0,78	1,00	0,80	1,04	0,81	1,09	0,82	1,11	0,82	1,14	0,83
14	0,80	0,74	0,85	0,75	0,95	0,79	1,00	0,80	1,04	0,81	1,09	0,82	1,11	0,83	1,13	0,83
16	0,80	0,74	0,85	0,75	0,95	0,79	1,00	0,81	1,04	0,82	1,09	0,83	1,11	0,83	1,13	0,83
18	0,80	0,74	0,85	0,76	0,95	0,80	1,00	0,81	1,04	0,82	1,09	0,84	1,11	0,84	1,13	0,84
20	0,80	0,75	0,85	0,76	0,95	0,81	1,00	0,82	1,04	0,83	1,09	0,84	1,11	0,84	1,13	0,85
22	0,80	0,76	0,85	0,77	0,95	0,81	1,00	0,83	1,04	0,84	1,09	0,85	1,11	0,85	1,13	0,86
24	0,80	0,77	0,85	0,78	0,95	0,83	1,00	0,84	1,04	0,85	1,09	0,87	1,11	0,87	1,13	0,87
25	0,79	0,78	0,85	0,79	0,95	0,83	1,00	0,85	1,04	0,86	1,09	0,87	1,11	0,87	1,13	0,88
26	0,79	0,78	0,85	0,80	0,95	0,84	1,00	0,86	1,04	0,87	1,09	0,88	1,11	0,88	1,13	0,89
28	0,79	0,80	0,85	0,82	0,95	0,86	1,00	0,88	1,04	0,89	1,09	0,90	1,11	0,90	1,13	0,91
30	0,79	0,82	0,85	0,84	0,95	0,88	1,00	0,90	1,04	0,90	1,09	0,92	1,11	0,92	1,13	0,93
32	0,79	0,86	0,85	0,87	0,95	0,92	1,00	0,94	1,03	0,94	1,08	0,96	1,10	0,96	1,12	0,97
34	0,79	0,90	0,85	0,91	0,95	0,96	1,00	0,98	1,03	0,98	1,08	0,99	1,09	1,00	1,11	1,00
35	0,79	0,92	0,85	0,93	0,95	0,98	1,00	1,00	1,03	1,00	1,07	1,01	1,09	1,02	1,11	1,02
36	0,79	0,94	0,84	0,96	0,94	1,00	0,98	1,02	1,01	1,02	1,06	1,03	1,07	1,04	1,09	1,04
38	0,78	0,99	0,83	1,01	0,92	1,05	0,95	1,06	0,98	1,06	1,02	1,07	1,03	1,08	1,05	1,08
40	0,77	1,04	0,82	1,06	0,90	1,09	0,92	1,10	0,95	1,10	0,98	1,11	1,00	1,11	1,01	1,11

**RAS-26FSXN**

To\Ti	14		16		18		19		20		22		23		24	
	Q	P	Q	P	Q	P	Q	P	Q	P	Q	P	Q	P	Q	P
10	0,81	0,75	0,87	0,77	0,96	0,79	1,00	0,80	1,05	0,81	1,10	0,83	1,13	0,83	1,16	0,84
12	0,81	0,75	0,87	0,77	0,96	0,79	1,00	0,80	1,05	0,82	1,10	0,83	1,13	0,83	1,16	0,84
14	0,81	0,76	0,87	0,77	0,96	0,80	1,00	0,81	1,05	0,82	1,10	0,83	1,13	0,84	1,15	0,85
16	0,81	0,76	0,87	0,77	0,96	0,80	1,00	0,81	1,05	0,82	1,10	0,84	1,13	0,84	1,15	0,85
18	0,81	0,76	0,87	0,78	0,96	0,81	1,00	0,82	1,05	0,83	1,10	0,84	1,13	0,85	1,15	0,86
20	0,81	0,77	0,87	0,79	0,96	0,82	1,00	0,82	1,05	0,84	1,10	0,85	1,13	0,86	1,15	0,86
22	0,81	0,78	0,87	0,80	0,96	0,82	1,00	0,83	1,05	0,84	1,10	0,86	1,13	0,87	1,15	0,87
24	0,81	0,79	0,87	0,81	0,96	0,84	1,00	0,84	1,04	0,86	1,10	0,87	1,13	0,88	1,15	0,89
25	0,81	0,80	0,87	0,81	0,96	0,84	1,00	0,85	1,04	0,86	1,10	0,88	1,13	0,88	1,15	0,89
26	0,81	0,81	0,87	0,82	0,96	0,85	1,00	0,86	1,04	0,88	1,10	0,89	1,13	0,90	1,15	0,90
28	0,81	0,83	0,87	0,85	0,96	0,88	1,00	0,89	1,04	0,90	1,10	0,92	1,13	0,92	1,15	0,93
30	0,81	0,86	0,87	0,87	0,96	0,90	1,00	0,91	1,04	0,92	1,10	0,94	1,13	0,94	1,15	0,95
32	0,81	0,89	0,87	0,91	0,96	0,94	1,00	0,95	1,04	0,96	1,10	0,98	1,12	0,98	1,14	0,99
34	0,81	0,93	0,87	0,95	0,96	0,97	1,00	0,98	1,04	0,99	1,09	1,02	1,11	1,02	1,12	1,03
35	0,81	0,95	0,87	0,97	0,96	0,99	1,00	1,00	1,04	1,01	1,09	1,03	1,11	1,04	1,12	1,05
36	0,80	0,98	0,86	0,99	0,95	1,02	0,99	1,03	1,02	1,04	1,07	1,05	1,08	1,06	1,10	1,07
38	0,79	1,03	0,85	1,05	0,93	1,07	0,96	1,08	0,99	1,08	1,03	1,09	1,04	1,10	1,05	1,10
40	0,78	1,08	0,84	1,10	0,91	1,13	0,94	1,13	0,96	1,13	0,99	1,13	1,00	1,13	1,01	1,13



**RAS-28FSXN**

To\Ti	14		16		18		19		20		22		23		24	
	Q	P	Q	P	Q	P	Q	P	Q	P	Q	P	Q	P	Q	P
10	0,81	0,74	0,86	0,75	0,96	0,78	1,00	0,79	1,05	0,80	1,10	0,82	1,12	0,83	1,15	0,83
12	0,81	0,74	0,86	0,75	0,96	0,78	1,00	0,80	1,05	0,81	1,10	0,82	1,12	0,83	1,15	0,83
14	0,81	0,74	0,86	0,76	0,96	0,79	1,00	0,80	1,04	0,81	1,10	0,82	1,12	0,83	1,15	0,83
16	0,81	0,75	0,86	0,76	0,96	0,79	1,00	0,80	1,04	0,81	1,10	0,83	1,12	0,83	1,15	0,84
18	0,81	0,75	0,86	0,77	0,96	0,79	1,00	0,81	1,04	0,82	1,10	0,83	1,12	0,84	1,15	0,84
20	0,81	0,76	0,86	0,77	0,96	0,80	1,00	0,82	1,04	0,83	1,10	0,84	1,12	0,85	1,14	0,85
22	0,81	0,77	0,86	0,78	0,96	0,81	1,00	0,82	1,04	0,84	1,10	0,85	1,12	0,86	1,14	0,86
24	0,81	0,78	0,86	0,79	0,96	0,82	1,00	0,84	1,04	0,85	1,10	0,86	1,12	0,87	1,14	0,87
25	0,81	0,79	0,86	0,80	0,96	0,83	1,00	0,84	1,04	0,85	1,10	0,87	1,12	0,88	1,14	0,88
26	0,81	0,80	0,86	0,81	0,96	0,84	1,00	0,85	1,04	0,87	1,10	0,88	1,12	0,89	1,14	0,89
28	0,80	0,82	0,86	0,84	0,96	0,87	1,00	0,88	1,04	0,89	1,10	0,91	1,12	0,91	1,14	0,92
30	0,80	0,85	0,86	0,86	0,96	0,89	1,00	0,90	1,04	0,92	1,10	0,93	1,12	0,93	1,14	0,94
32	0,80	0,88	0,86	0,90	0,96	0,93	1,00	0,94	1,04	0,95	1,09	0,97	1,11	0,97	1,13	0,98
34	0,80	0,92	0,86	0,94	0,96	0,97	1,00	0,98	1,04	0,99	1,09	1,01	1,10	1,01	1,12	1,02
35	0,80	0,94	0,86	0,95	0,96	0,99	1,00	1,00	1,04	1,01	1,09	1,03	1,10	1,03	1,11	1,04
36	0,80	0,96	0,86	0,98	0,95	1,01	0,99	1,02	1,02	1,03	1,06	1,05	1,08	1,05	1,09	1,05
38	0,79	1,01	0,84	1,03	0,93	1,06	0,96	1,07	0,99	1,08	1,02	1,08	1,03	1,08	1,04	1,09
40	0,77	1,07	0,83	1,09	0,91	1,12	0,93	1,12	0,95	1,12	0,98	1,12	0,99	1,12	1,00	1,12

**RAS-30FSXN**

To\Ti	14		16		18		19		20		22		23		24	
	Q	P	Q	P	Q	P	Q	P	Q	P	Q	P	Q	P	Q	P
10	0,81	0,74	0,86	0,76	0,96	0,78	1,00	0,80	1,05	0,81	1,10	0,82	1,12	0,82	1,15	0,83
12	0,81	0,74	0,86	0,76	0,96	0,78	1,00	0,80	1,05	0,81	1,10	0,82	1,12	0,82	1,15	0,83
14	0,81	0,75	0,86	0,76	0,96	0,78	1,00	0,80	1,04	0,81	1,10	0,82	1,12	0,83	1,15	0,83
16	0,81	0,75	0,86	0,76	0,96	0,79	1,00	0,80	1,04	0,81	1,10	0,83	1,12	0,83	1,15	0,84
18	0,81	0,75	0,86	0,77	0,96	0,79	1,00	0,81	1,04	0,82	1,10	0,83	1,12	0,84	1,15	0,84
20	0,81	0,76	0,86	0,78	0,96	0,80	1,00	0,82	1,04	0,83	1,10	0,84	1,12	0,84	1,14	0,85
22	0,81	0,77	0,86	0,78	0,96	0,81	1,00	0,83	1,04	0,84	1,10	0,85	1,12	0,86	1,14	0,86
24	0,81	0,78	0,86	0,79	0,96	0,82	1,00	0,84	1,04	0,85	1,10	0,86	1,12	0,87	1,14	0,87
25	0,81	0,79	0,86	0,80	0,96	0,83	1,00	0,84	1,04	0,86	1,10	0,87	1,12	0,87	1,14	0,88
26	0,81	0,80	0,86	0,81	0,96	0,84	1,00	0,86	1,04	0,87	1,10	0,88	1,12	0,89	1,14	0,89
28	0,81	0,82	0,86	0,84	0,96	0,87	1,00	0,88	1,04	0,89	1,10	0,91	1,12	0,91	1,14	0,92
30	0,81	0,85	0,86	0,86	0,96	0,89	1,00	0,90	1,04	0,91	1,10	0,93	1,12	0,94	1,14	0,94
32	0,80	0,88	0,86	0,90	0,96	0,93	1,00	0,94	1,04	0,95	1,09	0,97	1,11	0,97	1,13	0,98
34	0,80	0,92	0,86	0,94	0,96	0,97	1,00	0,98	1,04	0,99	1,08	1,01	1,09	1,01	1,11	1,01
35	0,81	0,94	0,86	0,96	0,96	0,99	1,00	1,00	1,04	1,01	1,08	1,03	1,09	1,03	1,10	1,03
36	0,80	0,97	0,86	0,99	0,94	1,01	0,98	1,02	1,02	1,03	1,05	1,04	1,06	1,04	1,07	1,05
38	0,78	1,02	0,84	1,04	0,92	1,06	0,95	1,06	0,98	1,07	1,01	1,07	1,02	1,07	1,02	1,08
40	0,77	1,07	0,82	1,09	0,90	1,10	0,92	1,10	0,94	1,10	0,96	1,10	0,97	1,10	0,97	1,10

**RAS-32FSXN**

To\Ti	14		16		18		19		20		22		23		24	
	Q	P	Q	P	Q	P	Q	P	Q	P	Q	P	Q	P	Q	P
10	0,81	0,74	0,86	0,75	0,96	0,79	1,00	0,79	1,05	0,80	1,10	0,82	1,12	0,82	1,15	0,83
12	0,81	0,74	0,86	0,75	0,96	0,79	1,00	0,80	1,05	0,81	1,10	0,82	1,12	0,82	1,15	0,83
14	0,81	0,74	0,86	0,76	0,96	0,79	1,00	0,80	1,04	0,81	1,10	0,82	1,12	0,83	1,15	0,83
16	0,81	0,75	0,86	0,76	0,96	0,79	1,00	0,80	1,04	0,81	1,10	0,83	1,12	0,83	1,15	0,84
18	0,81	0,75	0,86	0,77	0,96	0,80	1,00	0,81	1,04	0,82	1,10	0,84	1,12	0,84	1,15	0,84
20	0,81	0,76	0,86	0,77	0,96	0,81	1,00	0,82	1,04	0,83	1,10	0,84	1,12	0,84	1,14	0,85
22	0,81	0,77	0,86	0,78	0,96	0,82	1,00	0,82	1,04	0,84	1,10	0,85	1,12	0,86	1,14	0,86
24	0,81	0,78	0,86	0,79	0,96	0,83	1,00	0,84	1,04	0,85	1,10	0,86	1,12	0,87	1,14	0,87
25	0,81	0,78	0,86	0,80	0,96	0,83	1,00	0,84	1,04	0,85	1,10	0,87	1,12	0,87	1,14	0,88
26	0,81	0,80	0,86	0,81	0,96	0,84	1,00	0,86	1,04	0,87	1,10	0,88	1,12	0,89	1,14	0,89
28	0,81	0,82	0,86	0,84	0,96	0,87	1,00	0,88	1,04	0,89	1,10	0,91	1,12	0,91	1,14	0,92
30	0,81	0,85	0,86	0,86	0,96	0,89	1,00	0,90	1,04	0,91	1,10	0,93	1,12	0,94	1,14	0,94
32	0,80	0,88	0,86	0,90	0,96	0,93	1,00	0,94	1,04	0,95	1,08	0,97	1,10	0,97	1,12	0,97
34	0,80	0,93	0,86	0,94	0,96	0,97	1,00	0,98	1,03	0,99	1,07	1,00	1,09	1,01	1,10	1,01
35	0,80	0,95	0,86	0,96	0,96	0,99	1,00	1,00	1,03	1,01	1,07	1,02	1,08	1,02	1,09	1,02
36	0,80	0,97	0,85	0,99	0,94	1,01	0,98	1,02	1,01	1,02	1,04	1,04	1,05	1,04	1,06	1,04
38	0,78	1,02	0,84	1,04	0,91	1,05	0,95	1,05	0,97	1,06	0,99	1,06	1,00	1,06	1,01	1,06
40	0,76	1,07	0,82	1,09	0,89	1,09	0,91	1,09	0,92	1,09	0,94	1,09	0,95	1,09	0,95	1,09

**RAS-34FSXN**

To\Ti	14		16		18		19		20		22		23		24	
	Q	P	Q	P	Q	P	Q	P	Q	P	Q	P	Q	P	Q	P
10	0,81	0,74	0,86	0,75	0,96	0,78	1,00	0,79	1,05	0,80	1,10	0,82	1,12	0,83	1,15	0,83
12	0,81	0,74	0,86	0,75	0,96	0,78	1,00	0,80	1,05	0,81	1,10	0,82	1,12	0,83	1,15	0,83
14	0,81	0,74	0,86	0,76	0,96	0,79	1,00	0,80	1,04	0,81	1,10	0,82	1,12	0,83	1,15	0,83
16	0,81	0,75	0,86	0,76	0,96	0,79	1,00	0,80	1,04	0,81	1,10	0,83	1,12	0,83	1,15	0,84
18	0,81	0,75	0,86	0,77	0,95	0,80	1,00	0,81	1,04	0,82	1,10	0,83	1,12	0,84	1,15	0,84
20	0,81	0,76	0,86	0,77	0,95	0,81	1,00	0,82	1,04	0,83	1,10	0,84	1,12	0,85	1,14	0,85
22	0,81	0,77	0,86	0,78	0,95	0,81	1,00	0,82	1,04	0,84	1,10	0,85	1,12	0,86	1,14	0,86
24	0,81	0,78	0,86	0,79	0,95	0,83	1,00	0,84	1,04	0,85	1,10	0,86	1,12	0,87	1,14	0,87
25	0,81	0,78	0,86	0,80	0,95	0,83	1,00	0,84	1,04	0,85	1,10	0,87	1,12	0,88	1,14	0,88
26	0,81	0,80	0,86	0,81	0,95	0,84	1,00	0,86	1,04	0,87	1,10	0,88	1,12	0,89	1,14	0,89
28	0,81	0,82	0,86	0,84	0,95	0,87	1,00	0,88	1,04	0,89	1,10	0,91	1,12	0,91	1,14	0,92
30	0,81	0,85	0,86	0,86	0,95	0,89	1,00	0,90	1,04	0,91	1,10	0,93	1,12	0,94	1,14	0,94
32	0,80	0,89	0,86	0,90	0,95	0,93	1,00	0,94	1,04	0,95	1,08	0,97	1,10	0,97	1,12	0,97
34	0,80	0,93	0,86	0,94	0,95	0,97	1,00	0,98	1,03	0,99	1,07	1,01	1,09	1,01	1,10	1,01
35	0,80	0,95	0,86	0,96	0,95	0,99	1,00	1,00	1,03	1,01	1,07	1,03	1,08	1,03	1,09	1,03
36	0,80	0,97	0,85	0,99	0,94	1,01	0,98	1,02	1,01	1,03	1,04	1,04	1,05	1,04	1,06	1,04
38	0,78	1,02	0,84	1,04	0,91	1,05	0,95	1,05	0,97	1,06	0,99	1,06	1,00	1,06	1,01	1,06
40	0,76	1,07	0,82	1,09	0,89	1,09	0,91	1,09	0,92	1,09	0,94	1,09	0,95	1,09	0,95	1,09

**RAS-36FSXN**

To\Ti	14		16		18		19		20		22		23		24	
	Q	P	Q	P	Q	P	Q	P	Q	P	Q	P	Q	P	Q	P
10	0,81	0,74	0,86	0,75	0,96	0,78	1,00	0,80	1,05	0,81	1,10	0,82	1,12	0,82	1,15	0,83
12	0,81	0,74	0,86	0,75	0,96	0,78	1,00	0,80	1,05	0,81	1,10	0,82	1,12	0,82	1,15	0,83
14	0,81	0,74	0,86	0,76	0,96	0,79	1,00	0,80	1,04	0,81	1,10	0,82	1,12	0,83	1,15	0,83
16	0,81	0,75	0,86	0,76	0,96	0,79	1,00	0,80	1,04	0,82	1,10	0,83	1,12	0,83	1,15	0,84
18	0,81	0,75	0,86	0,77	0,96	0,80	1,00	0,81	1,04	0,82	1,10	0,84	1,12	0,84	1,15	0,84
20	0,81	0,76	0,86	0,77	0,96	0,81	1,00	0,82	1,04	0,83	1,10	0,84	1,12	0,85	1,14	0,85
22	0,80	0,77	0,86	0,78	0,96	0,81	1,00	0,83	1,04	0,84	1,10	0,85	1,12	0,86	1,14	0,86
24	0,80	0,78	0,86	0,79	0,96	0,83	1,00	0,84	1,04	0,85	1,10	0,86	1,12	0,87	1,14	0,87
25	0,81	0,78	0,86	0,80	0,96	0,83	1,00	0,84	1,04	0,86	1,10	0,87	1,12	0,87	1,14	0,88
26	0,81	0,80	0,86	0,81	0,96	0,84	1,00	0,86	1,04	0,87	1,10	0,88	1,12	0,89	1,14	0,89
28	0,81	0,82	0,86	0,84	0,96	0,87	1,00	0,88	1,04	0,89	1,10	0,91	1,12	0,91	1,14	0,92
30	0,81	0,85	0,86	0,86	0,96	0,89	1,00	0,90	1,04	0,92	1,10	0,93	1,12	0,93	1,14	0,94
32	0,80	0,88	0,86	0,90	0,96	0,93	1,00	0,94	1,04	0,95	1,08	0,97	1,10	0,97	1,12	0,97
34	0,80	0,93	0,86	0,94	0,96	0,97	1,00	0,98	1,03	0,99	1,07	1,01	1,09	1,01	1,10	1,01
35	0,80	0,95	0,86	0,96	0,96	0,99	1,00	1,00	1,03	1,01	1,07	1,02	1,08	1,02	1,09	1,02
36	0,80	0,97	0,85	0,99	0,94	1,01	0,98	1,02	1,01	1,03	1,04	1,04	1,05	1,04	1,06	1,04
38	0,78	1,02	0,84	1,04	0,91	1,05	0,95	1,05	0,97	1,06	0,99	1,06	1,00	1,06	1,01	1,06
40	0,76	1,07	0,82	1,09	0,89	1,09	0,91	1,09	0,92	1,09	0,94	1,09	0,95	1,09	0,95	1,09

4

**RAS-38FSXN**

To\Ti	14		16		18		19		20		22		23		24	
	Q	P	Q	P	Q	P	Q	P	Q	P	Q	P	Q	P	Q	P
10	0,79	0,72	0,85	0,74	0,95	0,78	1,00	0,79	1,04	0,79	1,08	0,80	1,11	0,81	1,13	0,81
12	0,79	0,72	0,85	0,74	0,95	0,78	1,00	0,79	1,04	0,80	1,08	0,80	1,11	0,81	1,13	0,81
14	0,79	0,73	0,85	0,74	0,95	0,78	1,00	0,79	1,04	0,80	1,08	0,81	1,10	0,81	1,13	0,82
16	0,79	0,73	0,85	0,74	0,95	0,78	1,00	0,80	1,04	0,80	1,08	0,81	1,10	0,81	1,13	0,82
18	0,79	0,73	0,85	0,75	0,95	0,79	1,00	0,80	1,04	0,81	1,08	0,82	1,10	0,82	1,13	0,83
20	0,79	0,74	0,85	0,75	0,95	0,80	1,00	0,81	1,04	0,82	1,08	0,83	1,10	0,83	1,13	0,83
22	0,79	0,75	0,85	0,76	0,95	0,80	1,00	0,82	1,04	0,82	1,08	0,84	1,10	0,84	1,13	0,84
24	0,79	0,76	0,85	0,77	0,95	0,82	1,00	0,83	1,04	0,84	1,08	0,85	1,10	0,85	1,13	0,85
25	0,79	0,77	0,85	0,78	0,95	0,82	1,00	0,84	1,03	0,84	1,08	0,85	1,10	0,86	1,12	0,86
26	0,79	0,78	0,85	0,79	0,95	0,83	1,00	0,85	1,03	0,85	1,08	0,87	1,10	0,87	1,12	0,87
28	0,79	0,80	0,85	0,82	0,95	0,86	1,00	0,87	1,03	0,88	1,08	0,89	1,10	0,89	1,12	0,90
30	0,79	0,83	0,85	0,84	0,95	0,88	1,00	0,90	1,03	0,90	1,08	0,91	1,10	0,92	1,12	0,92
32	0,79	0,86	0,85	0,88	0,95	0,92	1,00	0,94	1,03	0,94	1,07	0,95	1,09	0,95	1,11	0,96
34	0,79	0,90	0,85	0,92	0,95	0,96	1,00	0,98	1,03	0,98	1,07	0,99	1,08	0,99	1,10	0,99
35	0,79	0,92	0,85	0,94	0,95	0,98	1,00	1,00	1,03	1,00	1,07	1,01	1,08	1,01	1,09	1,01
36	0,78	0,94	0,84	0,96	0,94	1,00	0,98	1,02	1,01	1,02	1,04	1,02	1,06	1,03	1,07	1,03
38	0,77	0,99	0,83	1,01	0,91	1,04	0,95	1,05	0,97	1,05	1,00	1,06	1,02	1,06	1,02	1,06
40	0,76	1,04	0,81	1,06	0,89	1,08	0,91	1,08	0,94	1,09	0,96	1,09	0,97	1,10	0,98	1,10

**RAS-40FSXN**

To\Ti	14		16		18		19		20		22		23		24	
	Q	P	Q	P	Q	P	Q	P	Q	P	Q	P	Q	P	Q	P
10	0,81	0,74	0,86	0,75	0,96	0,78	1,00	0,80	1,05	0,81	1,10	0,82	1,12	0,83	1,15	0,83
12	0,81	0,74	0,86	0,75	0,96	0,78	1,00	0,80	1,05	0,81	1,10	0,82	1,12	0,83	1,15	0,83
14	0,81	0,74	0,86	0,76	0,96	0,79	1,00	0,80	1,04	0,81	1,10	0,82	1,12	0,83	1,15	0,83
16	0,81	0,75	0,86	0,76	0,96	0,79	1,00	0,80	1,04	0,81	1,10	0,83	1,12	0,83	1,15	0,84
18	0,81	0,75	0,86	0,77	0,96	0,80	1,00	0,81	1,04	0,82	1,10	0,83	1,12	0,84	1,15	0,84
20	0,81	0,76	0,86	0,77	0,96	0,81	1,00	0,82	1,04	0,83	1,10	0,84	1,12	0,85	1,14	0,85
22	0,81	0,77	0,86	0,78	0,96	0,81	1,00	0,83	1,04	0,84	1,10	0,85	1,12	0,86	1,14	0,86
24	0,81	0,78	0,86	0,79	0,96	0,83	1,00	0,84	1,04	0,85	1,10	0,86	1,12	0,87	1,14	0,87
25	0,81	0,79	0,86	0,80	0,96	0,83	1,00	0,84	1,04	0,86	1,10	0,87	1,12	0,88	1,14	0,88
26	0,81	0,80	0,86	0,81	0,96	0,84	1,00	0,86	1,04	0,87	1,10	0,88	1,12	0,89	1,14	0,89
28	0,81	0,82	0,86	0,84	0,96	0,87	1,00	0,88	1,04	0,89	1,10	0,91	1,12	0,91	1,14	0,92
30	0,81	0,84	0,86	0,86	0,96	0,89	1,00	0,90	1,04	0,91	1,10	0,93	1,12	0,94	1,14	0,94
32	0,80	0,88	0,86	0,90	0,96	0,93	1,00	0,94	1,04	0,95	1,09	0,97	1,11	0,97	1,13	0,98
34	0,80	0,92	0,86	0,94	0,96	0,97	1,00	0,98	1,04	0,99	1,08	1,01	1,10	1,01	1,11	1,01
35	0,80	0,94	0,86	0,96	0,96	0,99	1,00	1,00	1,04	1,01	1,08	1,02	1,09	1,03	1,10	1,03
36	0,80	0,97	0,86	0,98	0,94	1,01	0,98	1,02	1,02	1,03	1,06	1,04	1,07	1,05	1,08	1,05
38	0,78	1,02	0,84	1,04	0,92	1,06	0,95	1,06	0,98	1,07	1,01	1,07	1,02	1,08	1,03	1,08
40	0,77	1,07	0,83	1,09	0,90	1,11	0,92	1,11	0,94	1,11	0,96	1,11	0,97	1,11	0,98	1,11

4

**RAS-42FSXN**

To\Ti	14		16		18		19		20		22		23		24	
	Q	P	Q	P	Q	P	Q	P	Q	P	Q	P	Q	P	Q	P
10	0,80	0,73	0,86	0,74	0,95	0,78	1,00	0,79	1,04	0,80	1,09	0,81	1,11	0,81	1,14	0,82
12	0,80	0,73	0,86	0,74	0,95	0,78	1,00	0,79	1,04	0,80	1,09	0,81	1,11	0,81	1,14	0,82
14	0,80	0,73	0,86	0,74	0,95	0,78	1,00	0,79	1,04	0,80	1,09	0,81	1,11	0,81	1,14	0,82
16	0,80	0,74	0,86	0,75	0,95	0,78	1,00	0,80	1,04	0,80	1,09	0,81	1,11	0,82	1,14	0,82
18	0,80	0,74	0,86	0,75	0,95	0,79	1,00	0,80	1,04	0,81	1,09	0,82	1,11	0,83	1,14	0,83
20	0,80	0,75	0,86	0,76	0,95	0,80	1,00	0,81	1,04	0,82	1,09	0,83	1,11	0,83	1,13	0,84
22	0,80	0,76	0,86	0,77	0,95	0,81	1,00	0,82	1,04	0,83	1,09	0,84	1,11	0,84	1,13	0,85
24	0,80	0,77	0,86	0,78	0,95	0,82	1,00	0,83	1,04	0,84	1,09	0,85	1,11	0,85	1,13	0,86
25	0,80	0,77	0,86	0,79	0,95	0,82	1,00	0,84	1,03	0,84	1,09	0,86	1,11	0,86	1,13	0,87
26	0,80	0,78	0,86	0,80	0,95	0,84	1,00	0,85	1,03	0,86	1,09	0,87	1,11	0,87	1,13	0,88
28	0,80	0,81	0,86	0,82	0,95	0,86	1,00	0,87	1,03	0,88	1,09	0,89	1,11	0,90	1,13	0,90
30	0,80	0,83	0,86	0,85	0,95	0,88	1,00	0,90	1,03	0,91	1,09	0,91	1,11	0,92	1,13	0,93
32	0,80	0,87	0,86	0,89	0,95	0,92	1,00	0,94	1,03	0,95	1,08	0,95	1,10	0,96	1,12	0,96
34	0,80	0,91	0,86	0,92	0,95	0,96	1,00	0,98	1,03	0,98	1,07	0,99	1,09	0,99	1,10	1,00
35	0,80	0,93	0,86	0,94	0,95	0,98	1,00	1,00	1,03	1,00	1,07	1,01	1,08	1,01	1,09	1,02
36	0,79	0,95	0,85	0,97	0,94	1,00	0,98	1,02	1,01	1,02	1,05	1,03	1,06	1,03	1,07	1,03
38	0,78	1,00	0,83	1,02	0,91	1,04	0,95	1,05	0,97	1,06	1,00	1,06	1,01	1,06	1,02	1,06
40	0,76	1,05	0,82	1,07	0,89	1,09	0,91	1,09	0,93	1,09	0,96	1,09	0,96	1,09	0,97	1,09



**RAS-44FSXN**

To\Ti	14		16		18		19		20		22		23		24	
	Q	P	Q	P	Q	P	Q	P	Q	P	Q	P	Q	P	Q	P
10	0,80	0,73	0,85	0,74	0,95	0,77	1,00	0,79	1,04	0,79	1,09	0,80	1,11	0,81	1,14	0,82
12	0,80	0,73	0,85	0,74	0,95	0,77	1,00	0,79	1,04	0,79	1,09	0,80	1,11	0,81	1,14	0,82
14	0,80	0,73	0,85	0,74	0,95	0,78	1,00	0,79	1,04	0,80	1,08	0,81	1,11	0,81	1,13	0,82
16	0,80	0,73	0,85	0,74	0,95	0,78	1,00	0,79	1,04	0,80	1,08	0,81	1,11	0,82	1,13	0,82
18	0,80	0,74	0,85	0,75	0,95	0,79	1,00	0,80	1,04	0,81	1,08	0,82	1,11	0,82	1,13	0,83
20	0,80	0,74	0,85	0,76	0,95	0,79	1,00	0,81	1,04	0,81	1,08	0,82	1,11	0,83	1,13	0,83
22	0,80	0,75	0,85	0,77	0,95	0,80	1,00	0,82	1,04	0,82	1,08	0,83	1,11	0,84	1,13	0,85
24	0,80	0,76	0,85	0,78	0,95	0,81	1,00	0,83	1,04	0,83	1,08	0,84	1,11	0,85	1,13	0,86
25	0,80	0,77	0,85	0,78	0,95	0,82	1,00	0,83	1,03	0,84	1,08	0,85	1,11	0,86	1,13	0,86
26	0,80	0,78	0,85	0,80	0,95	0,83	1,00	0,85	1,03	0,85	1,08	0,86	1,11	0,87	1,13	0,88
28	0,80	0,81	0,85	0,82	0,95	0,86	1,00	0,87	1,03	0,88	1,08	0,89	1,11	0,89	1,13	0,90
30	0,80	0,83	0,85	0,84	0,95	0,88	1,00	0,89	1,03	0,90	1,08	0,91	1,11	0,92	1,13	0,92
32	0,80	0,86	0,85	0,88	0,95	0,92	1,00	0,94	1,03	0,94	1,08	0,95	1,09	0,95	1,11	0,96
34	0,80	0,90	0,85	0,92	0,95	0,96	1,00	0,98	1,02	0,98	1,07	0,99	1,08	0,99	1,10	1,00
35	0,80	0,92	0,85	0,94	0,95	0,98	1,00	1,00	1,02	1,00	1,06	1,00	1,08	1,01	1,09	1,01
36	0,79	0,95	0,85	0,97	0,94	1,00	0,98	1,02	1,00	1,02	1,04	1,02	1,05	1,02	1,06	1,03
38	0,77	1,00	0,83	1,02	0,91	1,04	0,95	1,05	0,97	1,05	1,00	1,05	1,01	1,05	1,02	1,06
40	0,76	1,05	0,82	1,07	0,89	1,08	0,91	1,08	0,93	1,08	0,95	1,08	0,96	1,08	0,97	1,08

4

**RAS-46FSXN**

To\Ti	14		16		18		19		20		22		23		24	
	Q	P	Q	P	Q	P	Q	P	Q	P	Q	P	Q	P	Q	P
10	0,79	0,72	0,85	0,74	0,95	0,77	1,00	0,79	1,04	0,80	1,09	0,80	1,11	0,81	1,14	0,81
12	0,79	0,72	0,85	0,74	0,95	0,77	1,00	0,79	1,04	0,80	1,09	0,80	1,11	0,81	1,13	0,81
14	0,79	0,73	0,85	0,74	0,95	0,78	1,00	0,79	1,04	0,80	1,08	0,81	1,10	0,81	1,13	0,81
16	0,79	0,73	0,85	0,74	0,95	0,78	1,00	0,80	1,04	0,80	1,08	0,81	1,10	0,81	1,13	0,82
18	0,79	0,73	0,85	0,75	0,95	0,79	1,00	0,80	1,04	0,81	1,08	0,82	1,10	0,82	1,13	0,82
20	0,79	0,74	0,85	0,76	0,95	0,80	1,00	0,81	1,04	0,82	1,08	0,83	1,10	0,83	1,13	0,83
22	0,79	0,75	0,85	0,77	0,95	0,80	1,00	0,82	1,04	0,83	1,08	0,84	1,10	0,84	1,13	0,84
24	0,79	0,76	0,85	0,77	0,95	0,82	1,00	0,83	1,04	0,84	1,08	0,85	1,10	0,85	1,13	0,85
25	0,79	0,77	0,85	0,78	0,95	0,82	1,00	0,84	1,03	0,84	1,08	0,85	1,10	0,86	1,13	0,86
26	0,79	0,78	0,85	0,79	0,95	0,83	1,00	0,85	1,03	0,86	1,08	0,87	1,10	0,87	1,13	0,87
28	0,79	0,80	0,85	0,82	0,95	0,86	1,00	0,87	1,03	0,88	1,08	0,89	1,10	0,89	1,13	0,90
30	0,79	0,83	0,85	0,84	0,95	0,88	1,00	0,90	1,03	0,90	1,08	0,91	1,10	0,91	1,13	0,92
32	0,79	0,86	0,85	0,88	0,95	0,92	1,00	0,94	1,03	0,94	1,07	0,95	1,09	0,95	1,10	0,95
34	0,79	0,90	0,85	0,91	0,95	0,96	1,00	0,98	1,02	0,98	1,05	0,98	1,07	0,98	1,08	0,98
35	0,79	0,92	0,85	0,93	0,95	0,98	1,00	1,00	1,02	1,00	1,04	1,00	1,06	1,00	1,07	1,00
36	0,78	0,94	0,84	0,96	0,93	1,00	0,98	1,01	1,00	1,01	1,02	1,01	1,03	1,01	1,04	1,01
38	0,76	0,99	0,82	1,01	0,90	1,03	0,93	1,04	0,95	1,04	0,97	1,04	0,98	1,04	0,99	1,04
40	0,75	1,04	0,80	1,06	0,87	1,06	0,89	1,06	0,91	1,06	0,93	1,07	0,93	1,07	0,94	1,07

**RAS-48FSXN**

To\Ti	14		16		18		19		20		22		23		24	
	Q	P	Q	P	Q	P	Q	P	Q	P	Q	P	Q	P	Q	P
10	0,79	0,72	0,85	0,74	0,95	0,78	1,00	0,79	1,04	0,80	1,09	0,81	1,11	0,81	1,14	0,81
12	0,79	0,72	0,85	0,74	0,95	0,78	1,00	0,79	1,04	0,80	1,08	0,81	1,11	0,81	1,13	0,81
14	0,79	0,73	0,85	0,74	0,95	0,78	1,00	0,80	1,04	0,80	1,08	0,81	1,10	0,81	1,13	0,82
16	0,79	0,73	0,85	0,74	0,95	0,78	1,00	0,80	1,04	0,81	1,08	0,81	1,10	0,82	1,13	0,82
18	0,79	0,74	0,85	0,75	0,95	0,79	1,00	0,81	1,04	0,81	1,08	0,82	1,10	0,82	1,13	0,83
20	0,79	0,74	0,85	0,76	0,95	0,80	1,00	0,81	1,04	0,82	1,08	0,83	1,10	0,83	1,13	0,83
22	0,79	0,75	0,85	0,77	0,95	0,80	1,00	0,82	1,04	0,83	1,08	0,84	1,10	0,84	1,13	0,84
24	0,79	0,76	0,85	0,78	0,95	0,82	1,00	0,83	1,04	0,84	1,08	0,85	1,10	0,85	1,13	0,85
25	0,79	0,77	0,85	0,78	0,95	0,82	1,00	0,84	1,04	0,85	1,08	0,86	1,10	0,86	1,13	0,86
26	0,79	0,78	0,85	0,79	0,95	0,83	1,00	0,85	1,04	0,86	1,08	0,87	1,10	0,87	1,13	0,87
28	0,79	0,80	0,85	0,82	0,95	0,86	1,00	0,88	1,04	0,89	1,08	0,89	1,10	0,89	1,13	0,90
30	0,79	0,83	0,85	0,84	0,95	0,88	1,00	0,90	1,04	0,91	1,08	0,91	1,10	0,92	1,13	0,92
32	0,79	0,87	0,85	0,88	0,95	0,92	1,00	0,94	1,03	0,95	1,07	0,95	1,09	0,95	1,11	0,96
34	0,79	0,91	0,85	0,92	0,95	0,96	1,00	0,98	1,03	0,98	1,06	0,99	1,07	0,99	1,09	0,99
35	0,79	0,93	0,85	0,94	0,95	0,98	1,00	1,00	1,02	1,00	1,05	1,01	1,06	1,01	1,08	1,01
36	0,78	0,95	0,84	0,97	0,93	1,00	0,98	1,01	1,00	1,01	1,03	1,02	1,04	1,02	1,05	1,02
38	0,77	1,00	0,82	1,02	0,90	1,03	0,94	1,04	0,96	1,04	0,98	1,05	0,99	1,05	1,00	1,05
40	0,75	1,05	0,81	1,07	0,87	1,07	0,90	1,07	0,91	1,07	0,93	1,08	0,94	1,08	0,94	1,08

4

**RAS-50FSXN**

To\Ti	14		16		18		19		20		22		23		24	
	Q	P	Q	P	Q	P	Q	P	Q	P	Q	P	Q	P	Q	P
10	0,81	0,74	0,86	0,75	0,96	0,78	1,00	0,80	1,05	0,81	1,10	0,82	1,12	0,83	1,15	0,83
12	0,81	0,74	0,86	0,75	0,96	0,78	1,00	0,80	1,05	0,81	1,10	0,82	1,12	0,83	1,15	0,83
14	0,81	0,74	0,86	0,76	0,96	0,79	1,00	0,80	1,04	0,81	1,10	0,82	1,12	0,83	1,15	0,83
16	0,81	0,75	0,86	0,76	0,96	0,79	1,00	0,80	1,04	0,81	1,10	0,83	1,12	0,83	1,15	0,84
18	0,81	0,75	0,86	0,77	0,96	0,80	1,00	0,81	1,04	0,82	1,10	0,84	1,12	0,84	1,15	0,84
20	0,81	0,76	0,86	0,77	0,96	0,81	1,00	0,82	1,04	0,83	1,10	0,84	1,12	0,85	1,14	0,85
22	0,81	0,77	0,86	0,78	0,96	0,81	1,00	0,83	1,04	0,84	1,10	0,85	1,12	0,86	1,14	0,86
24	0,81	0,78	0,86	0,79	0,96	0,83	1,00	0,84	1,04	0,85	1,10	0,86	1,12	0,87	1,14	0,87
25	0,81	0,78	0,86	0,80	0,96	0,83	1,00	0,84	1,04	0,86	1,10	0,87	1,12	0,88	1,14	0,88
26	0,81	0,80	0,86	0,81	0,96	0,84	1,00	0,86	1,04	0,87	1,10	0,88	1,12	0,89	1,14	0,89
28	0,80	0,82	0,86	0,84	0,96	0,87	1,00	0,88	1,04	0,89	1,10	0,91	1,12	0,91	1,14	0,92
30	0,80	0,85	0,86	0,86	0,96	0,89	1,00	0,90	1,04	0,92	1,10	0,93	1,12	0,94	1,14	0,94
32	0,80	0,88	0,86	0,90	0,96	0,93	1,00	0,94	1,04	0,95	1,09	0,97	1,11	0,97	1,12	0,98
34	0,80	0,92	0,86	0,94	0,96	0,97	1,00	0,98	1,03	0,99	1,08	1,01	1,09	1,01	1,11	1,01
35	0,80	0,94	0,86	0,96	0,96	0,99	1,00	1,00	1,03	1,01	1,07	1,03	1,09	1,03	1,10	1,03
36	0,80	0,97	0,85	0,99	0,94	1,01	0,98	1,02	1,01	1,03	1,05	1,04	1,06	1,04	1,07	1,04
38	0,78	1,02	0,84	1,04	0,92	1,05	0,95	1,06	0,97	1,06	1,00	1,07	1,01	1,07	1,02	1,07
40	0,77	1,07	0,82	1,09	0,89	1,10	0,92	1,10	0,93	1,10	0,95	1,10	0,96	1,10	0,96	1,10

**RAS-52FSXN**

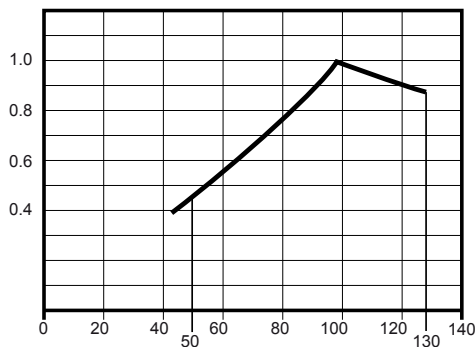
To\Ti	14		16		18		19		20		22		23		24	
	Q	P	Q	P	Q	P	Q	P	Q	P	Q	P	Q	P	Q	P
10	0,81	0,74	0,86	0,75	0,96	0,78	1,00	0,80	1,05	0,81	1,10	0,82	1,12	0,83	1,15	0,83
12	0,81	0,74	0,86	0,75	0,96	0,78	1,00	0,80	1,05	0,81	1,10	0,82	1,12	0,83	1,15	0,83
14	0,81	0,74	0,86	0,76	0,96	0,79	1,00	0,80	1,04	0,81	1,10	0,82	1,12	0,83	1,15	0,83
16	0,81	0,75	0,86	0,76	0,96	0,79	1,00	0,80	1,04	0,81	1,10	0,83	1,12	0,83	1,15	0,84
18	0,81	0,75	0,86	0,77	0,96	0,80	1,00	0,81	1,04	0,82	1,10	0,83	1,12	0,84	1,15	0,84
20	0,81	0,76	0,86	0,77	0,96	0,81	1,00	0,82	1,04	0,83	1,10	0,84	1,12	0,85	1,14	0,85
22	0,81	0,77	0,86	0,78	0,96	0,81	1,00	0,83	1,04	0,84	1,10	0,85	1,12	0,86	1,14	0,86
24	0,81	0,78	0,86	0,79	0,96	0,83	1,00	0,84	1,04	0,85	1,10	0,86	1,12	0,87	1,14	0,87
25	0,81	0,79	0,86	0,80	0,96	0,83	1,00	0,84	1,04	0,85	1,10	0,87	1,12	0,88	1,14	0,88
26	0,81	0,80	0,86	0,81	0,96	0,84	1,00	0,86	1,04	0,87	1,10	0,88	1,12	0,89	1,14	0,89
28	0,80	0,82	0,86	0,84	0,96	0,87	1,00	0,88	1,04	0,89	1,10	0,91	1,12	0,91	1,14	0,92
30	0,80	0,85	0,86	0,86	0,96	0,89	1,00	0,90	1,04	0,91	1,10	0,93	1,12	0,94	1,14	0,94
32	0,80	0,89	0,86	0,90	0,96	0,93	1,00	0,94	1,04	0,95	1,08	0,97	1,10	0,97	1,12	0,97
34	0,80	0,93	0,86	0,94	0,96	0,97	1,00	0,98	1,03	0,99	1,07	1,01	1,09	1,01	1,10	1,01
35	0,80	0,95	0,86	0,96	0,96	0,99	1,00	1,00	1,03	1,01	1,07	1,02	1,08	1,02	1,09	1,02
36	0,80	0,97	0,85	0,99	0,94	1,01	0,98	1,02	1,01	1,02	1,04	1,04	1,05	1,04	1,06	1,04
38	0,78	1,02	0,84	1,04	0,91	1,05	0,95	1,05	0,97	1,06	0,99	1,06	1,00	1,06	1,01	1,06
40	0,76	1,07	0,82	1,09	0,89	1,09	0,91	1,09	0,92	1,09	0,94	1,09	0,94	1,09	0,95	1,09

4

**RAS-54FSXN**

To\Ti	14		16		18		19		20		22		23		24	
	Q	P	Q	P	Q	P	Q	P	Q	P	Q	P	Q	P	Q	P
10	0,81	0,74	0,86	0,75	0,96	0,78	1,00	0,80	1,05	0,81	1,10	0,82	1,12	0,82	1,15	0,83
12	0,81	0,74	0,86	0,75	0,96	0,78	1,00	0,80	1,05	0,81	1,10	0,82	1,12	0,82	1,15	0,83
14	0,81	0,74	0,86	0,76	0,96	0,79	1,00	0,80	1,04	0,81	1,10	0,82	1,12	0,83	1,15	0,83
16	0,81	0,75	0,86	0,76	0,96	0,79	1,00	0,80	1,04	0,81	1,10	0,83	1,12	0,83	1,15	0,84
18	0,81	0,75	0,86	0,77	0,96	0,80	1,00	0,81	1,04	0,82	1,10	0,84	1,12	0,84	1,15	0,84
20	0,81	0,76	0,86	0,77	0,96	0,81	1,00	0,82	1,04	0,83	1,10	0,84	1,12	0,85	1,14	0,85
22	0,81	0,77	0,86	0,78	0,96	0,81	1,00	0,83	1,04	0,84	1,10	0,85	1,12	0,86	1,14	0,86
24	0,81	0,78	0,86	0,79	0,96	0,83	1,00	0,84	1,04	0,85	1,10	0,86	1,12	0,87	1,14	0,87
25	0,81	0,79	0,86	0,80	0,96	0,83	1,00	0,84	1,04	0,85	1,10	0,87	1,12	0,87	1,14	0,88
26	0,81	0,80	0,86	0,81	0,96	0,84	1,00	0,86	1,04	0,87	1,10	0,88	1,12	0,89	1,14	0,89
28	0,81	0,82	0,86	0,84	0,96	0,87	1,00	0,88	1,04	0,89	1,10	0,91	1,12	0,91	1,14	0,92
30	0,81	0,85	0,86	0,86	0,96	0,89	1,00	0,90	1,04	0,91	1,10	0,93	1,12	0,93	1,14	0,94
32	0,80	0,89	0,86	0,90	0,96	0,93	1,00	0,94	1,04	0,95	1,08	0,97	1,10	0,97	1,12	0,97
34	0,80	0,93	0,86	0,94	0,96	0,97	1,00	0,98	1,03	0,99	1,07	1,01	1,09	1,01	1,10	1,01
35	0,80	0,95	0,86	0,96	0,96	0,99	1,00	1,00	1,03	1,01	1,07	1,03	1,08	1,03	1,09	1,03
36	0,80	0,97	0,85	0,99	0,94	1,01	0,98	1,02	1,01	1,02	1,04	1,04	1,05	1,04	1,06	1,04
38	0,78	1,02	0,84	1,04	0,91	1,05	0,95	1,05	0,97	1,06	0,99	1,06	1,00	1,06	1,01	1,06
40	0,76	1,07	0,82	1,09	0,89	1,09	0,91	1,09	0,92	1,09	0,94	1,09	0,95	1,09	0,95	1,09

## 4.4 Nominal heating capacity tables



The following charts and tables show the characteristics of outdoor unit capacity in heating mode which corresponds with total horsepower of combined indoor unit, on standard condition with refrigerant piping of horizontal and 7.5m at length.

Indoor Air Inlet Temperature:	20.0°C DB (68.0°F DB)	-
Outdoor Air Inlet Temperature:	7.0°C DB (45.0°F DB)	6.0°C WB (43.0°F WB)

DB: Dry bulb

WB: Wet bulb

### RAS-8FSXN

To\Ti	16		18		20		21		22		24	
	Q	P	Q	P	Q	P	Q	P	Q	P	Q	P
-20	0,57	0,95	0,57	1,00	0,57	1,04	0,57	1,07	0,57	1,09	0,57	1,14
-17	0,64	0,96	0,64	1,01	0,64	1,05	0,64	1,08	0,64	1,10	0,64	1,15
-15	0,68	0,97	0,68	1,01	0,68	1,06	0,68	1,09	0,68	1,11	0,68	1,16
-13	0,72	0,97	0,72	1,02	0,72	1,07	0,72	1,09	0,72	1,11	0,72	1,17
-11	0,76	0,97	0,76	1,02	0,76	1,07	0,76	1,09	0,76	1,12	0,76	1,17
-10	0,78	0,97	0,78	1,02	0,78	1,07	0,78	1,09	0,78	1,12	0,78	1,17
-9	0,80	0,98	0,80	1,02	0,80	1,07	0,80	1,10	0,80	1,12	0,79	1,16
-7	0,84	1,00	0,84	1,04	0,84	1,08	0,83	1,10	0,83	1,11	0,82	1,13
-6	0,86	1,01	0,86	1,05	0,86	1,08	0,85	1,09	0,85	1,11	0,83	1,12
-5	0,88	1,00	0,88	1,04	0,88	1,09	0,88	1,12	0,88	1,13	0,86	1,13
-3	0,92	1,03	0,92	1,07	0,91	1,09	0,91	1,10	0,90	1,10	0,87	1,08
-1	0,96	1,07	0,95	1,09	0,94	1,08	0,94	1,08	0,92	1,07	0,88	1,03
0	0,98	1,08	0,97	1,10	0,96	1,08	0,95	1,07	0,94	1,05	0,88	1,00
1	0,99	1,08	0,98	1,09	0,97	1,07	0,96	1,05	0,94	1,03	0,88	0,98
3	1,01	1,07	1,00	1,08	0,98	1,05	0,97	1,03	0,95	1,00	0,88	0,94
5	1,04	1,06	1,02	1,06	0,99	1,03	0,98	1,00	0,96	0,97	0,88	0,90
6	1,06	1,05	1,03	1,04	1,00	1,00	0,98	0,97	0,96	0,95	0,88	0,88
7	1,08	1,05	1,04	1,03	1,01	0,99	0,99	0,96	0,96	0,93	0,88	0,86
9	1,11	1,04	1,07	1,01	1,02	0,96	0,99	0,93	0,96	0,90	0,88	0,84
10	1,13	1,04	1,08	1,00	1,02	0,94	0,99	0,91	0,96	0,88	0,88	0,82
11	1,13	1,03	1,08	0,99	1,02	0,93	0,99	0,90	0,96	0,87	0,88	0,81

4

14	1,13	1,01	1,08	0,96	1,02	0,90	0,99	0,87	0,96	0,84	0,88	0,77
15	1,13	1,00	1,08	0,95	1,02	0,89	0,99	0,86	0,96	0,83	0,88	0,76



**RAS-10FSXN**

To\Ti	16		18		20		21		22		24	
	Q	P	Q	P	Q	P	Q	P	Q	P	Q	P
-20	0,53	0,88	0,53	0,92	0,53	0,97	0,53	0,99	0,53	1,02	0,53	1,06
-17	0,59	0,89	0,59	0,93	0,59	0,98	0,59	1,00	0,59	1,03	0,59	1,07
-15	0,63	0,89	0,63	0,94	0,63	0,98	0,63	1,01	0,63	1,03	0,63	1,08
-13	0,66	0,90	0,66	0,94	0,66	0,99	0,66	1,01	0,66	1,04	0,66	1,08
-11	0,70	0,90	0,70	0,94	0,70	0,99	0,70	1,01	0,70	1,04	0,70	1,09
-10	0,72	0,90	0,72	0,94	0,72	0,99	0,72	1,01	0,72	1,04	0,72	1,09
-9	0,74	0,90	0,74	0,95	0,74	0,99	0,74	1,02	0,74	1,04	0,74	1,09
-7	0,78	0,92	0,78	0,96	0,78	1,01	0,78	1,03	0,78	1,06	0,77	1,09
-6	0,80	0,92	0,80	0,97	0,80	1,01	0,80	1,04	0,79	1,06	0,79	1,09
-5	0,83	0,93	0,83	0,97	0,82	1,02	0,82	1,04	0,82	1,07	0,81	1,12
-3	0,86	0,94	0,86	0,99	0,86	1,03	0,85	1,05	0,85	1,08	0,84	1,09
-1	0,90	0,96	0,89	1,00	0,89	1,04	0,89	1,06	0,89	1,08	0,86	1,06
0	0,91	0,97	0,91	1,01	0,91	1,05	0,90	1,07	0,90	1,09	0,87	1,05
1	0,93	0,97	0,93	1,01	0,93	1,04	0,92	1,05	0,91	1,06	0,87	1,01
3	0,97	0,97	0,96	1,02	0,96	1,03	0,95	1,02	0,93	1,01	0,88	0,94
5	1,01	0,98	1,00	1,03	0,99	1,02	0,98	0,99	0,95	0,95	0,88	0,88
6	1,04	0,98	1,03	1,03	1,00	1,00	0,98	0,97	0,96	0,93	0,88	0,86
7	1,06	0,98	1,04	1,02	1,00	0,98	0,99	0,95	0,96	0,91	0,88	0,84
9	1,08	0,99	1,06	1,00	1,01	0,95	0,99	0,92	0,96	0,88	0,88	0,81
10	1,10	0,99	1,07	0,99	1,02	0,94	0,99	0,90	0,96	0,87	0,88	0,80
11	1,10	0,98	1,07	0,97	1,02	0,92	0,99	0,89	0,96	0,85	0,88	0,79
14	1,13	0,98	1,08	0,94	1,02	0,88	0,99	0,85	0,96	0,82	0,88	0,75
15	1,13	0,98	1,08	0,92	1,02	0,87	0,99	0,84	0,96	0,80	0,88	0,74

4

**RAS-12FSXN**

To\Ti	16		18		20		21		22		24	
	Q	P	Q	P	Q	P	Q	P	Q	P	Q	P
-20	0,48	0,83	0,48	0,88	0,48	0,92	0,48	0,94	0,48	0,97	0,48	1,02
-17	0,53	0,84	0,53	0,88	0,53	0,93	0,53	0,95	0,53	0,98	0,53	1,03
-15	0,57	0,85	0,57	0,89	0,57	0,94	0,57	0,96	0,56	0,98	0,56	1,03
-13	0,60	0,85	0,60	0,89	0,60	0,94	0,60	0,96	0,60	0,99	0,60	1,04
-11	0,63	0,85	0,63	0,90	0,63	0,94	0,63	0,96	0,63	0,99	0,63	1,04
-10	0,65	0,85	0,65	0,90	0,65	0,94	0,65	0,96	0,65	0,99	0,65	1,04
-9	0,67	0,86	0,67	0,90	0,67	0,95	0,67	0,97	0,67	1,00	0,67	1,05
-7	0,72	0,88	0,72	0,92	0,72	0,97	0,72	0,99	0,72	1,02	0,71	1,06
-6	0,74	0,89	0,74	0,93	0,74	0,97	0,74	1,00	0,74	1,03	0,73	1,07
-5	0,77	0,90	0,77	0,94	0,77	0,98	0,77	1,01	0,76	1,04	0,76	1,09
-3	0,81	0,91	0,81	0,96	0,81	1,00	0,81	1,03	0,81	1,05	0,79	1,09
-1	0,86	0,93	0,86	0,97	0,86	1,02	0,85	1,05	0,85	1,07	0,83	1,10
0	0,88	0,94	0,88	0,98	0,88	1,03	0,88	1,06	0,87	1,08	0,85	1,10
1	0,90	0,94	0,90	0,98	0,90	1,03	0,89	1,05	0,89	1,06	0,86	1,05
3	0,94	0,93	0,94	0,98	0,94	1,02	0,93	1,02	0,92	1,01	0,87	0,97
5	0,98	0,93	0,98	0,98	0,98	1,01	0,97	1,00	0,95	0,96	0,88	0,88
6	1,02	0,93	1,02	0,97	1,00	1,00	0,98	0,97	0,95	0,93	0,88	0,85
7	1,03	0,93	1,03	0,97	1,01	0,98	0,99	0,95	0,95	0,91	0,88	0,83
9	1,06	0,94	1,05	0,97	1,02	0,94	0,99	0,91	0,95	0,87	0,88	0,80
10	1,08	0,94	1,06	0,97	1,02	0,92	0,99	0,89	0,95	0,85	0,88	0,79
11	1,09	0,94	1,06	0,96	1,02	0,91	0,99	0,88	0,95	0,84	0,88	0,77
14	1,12	0,96	1,08	0,92	1,02	0,86	0,99	0,83	0,95	0,80	0,88	0,73
15	1,13	0,96	1,08	0,91	1,02	0,85	0,99	0,82	0,95	0,79	0,88	0,72

## RAS-14FSXN

To\Ti	16		18		20		21		22		24	
	Q	P	Q	P	Q	P	Q	P	Q	P	Q	P
-20	0,53	0,88	0,53	0,93	0,53	0,97	0,53	1,00	0,53	1,02	0,53	1,07
-17	0,59	0,89	0,59	0,94	0,59	0,98	0,59	1,01	0,59	1,03	0,59	1,08
-15	0,63	0,89	0,63	0,94	0,63	0,99	0,63	1,01	0,63	1,04	0,62	1,09
-13	0,66	0,90	0,66	0,95	0,66	0,99	0,66	1,02	0,66	1,04	0,66	1,09
-11	0,70	0,90	0,70	0,95	0,70	0,99	0,70	1,02	0,70	1,04	0,70	1,09
-10	0,72	0,90	0,72	0,95	0,72	0,99	0,72	1,02	0,72	1,04	0,72	1,09
-9	0,74	0,90	0,74	0,95	0,74	1,00	0,74	1,02	0,74	1,05	0,74	1,10
-7	0,78	0,91	0,78	0,96	0,78	1,01	0,78	1,03	0,78	1,05	0,77	1,09
-6	0,80	0,92	0,80	0,96	0,80	1,01	0,80	1,03	0,79	1,06	0,78	1,08
-5	0,83	0,92	0,82	0,97	0,82	1,02	0,82	1,04	0,82	1,07	0,81	1,11
-3	0,86	0,93	0,86	0,98	0,86	1,02	0,85	1,05	0,85	1,07	0,84	1,08
-1	0,90	0,94	0,89	0,99	0,89	1,03	0,89	1,05	0,88	1,07	0,86	1,05
0	0,91	0,95	0,91	0,99	0,91	1,03	0,91	1,05	0,90	1,07	0,87	1,03
1	0,93	0,96	0,93	1,00	0,93	1,03	0,92	1,04	0,91	1,05	0,87	1,00
3	0,97	0,97	0,96	1,02	0,96	1,03	0,95	1,02	0,93	1,00	0,88	0,94
5	1,01	0,98	1,00	1,03	0,99	1,03	0,98	0,99	0,95	0,96	0,88	0,88
6	1,05	0,98	1,03	1,03	1,00	1,00	0,98	0,97	0,96	0,93	0,88	0,86
7	1,06	0,99	1,04	1,02	1,01	0,99	0,99	0,95	0,96	0,92	0,88	0,85
9	1,08	0,99	1,06	1,00	1,02	0,96	0,99	0,92	0,96	0,89	0,88	0,82
10	1,10	0,99	1,07	0,99	1,02	0,94	0,99	0,91	0,96	0,87	0,88	0,80
11	1,10	0,99	1,08	0,98	1,02	0,93	0,99	0,89	0,96	0,86	0,88	0,79
14	1,13	0,98	1,08	0,94	1,02	0,89	0,99	0,85	0,96	0,82	0,88	0,75
15	1,13	0,98	1,08	0,93	1,02	0,87	0,99	0,84	0,96	0,81	0,88	0,74

4

**RAS-16FSXN**

To\Ti	16		18		20		21		22		24	
	Q	P	Q	P	Q	P	Q	P	Q	P	Q	P
-20	0,52	0,83	0,52	0,88	0,52	0,92	0,52	0,94	0,51	0,97	0,51	1,02
-17	0,57	0,84	0,57	0,88	0,57	0,93	0,57	0,95	0,57	0,98	0,57	1,03
-15	0,61	0,85	0,61	0,89	0,61	0,94	0,61	0,96	0,61	0,99	0,61	1,03
-13	0,65	0,85	0,65	0,89	0,65	0,94	0,65	0,96	0,64	0,99	0,64	1,04
-11	0,68	0,85	0,68	0,90	0,68	0,94	0,68	0,96	0,68	0,99	0,68	1,04
-10	0,70	0,85	0,70	0,90	0,70	0,94	0,70	0,96	0,70	0,99	0,70	1,04
-9	0,72	0,86	0,72	0,90	0,72	0,95	0,72	0,97	0,72	1,00	0,72	1,05
-7	0,76	0,88	0,76	0,92	0,76	0,96	0,76	0,99	0,76	1,02	0,75	1,06
-6	0,78	0,88	0,78	0,93	0,78	0,97	0,78	1,00	0,78	1,03	0,77	1,07
-5	0,81	0,89	0,80	0,93	0,80	0,98	0,80	1,01	0,80	1,03	0,79	1,08
-3	0,85	0,91	0,84	0,95	0,84	1,00	0,84	1,03	0,84	1,05	0,82	1,09
-1	0,89	0,93	0,88	0,97	0,88	1,02	0,88	1,04	0,87	1,07	0,85	1,09
0	0,91	0,94	0,90	0,98	0,90	1,03	0,90	1,05	0,89	1,08	0,87	1,10
1	0,93	0,94	0,92	0,98	0,92	1,03	0,91	1,04	0,90	1,06	0,87	1,05
3	0,96	0,94	0,96	0,98	0,95	1,02	0,94	1,02	0,93	1,01	0,88	0,97
5	1,00	0,93	1,00	0,98	0,99	1,01	0,98	1,00	0,95	0,96	0,88	0,88
6	1,04	0,93	1,03	0,97	1,00	1,00	0,98	0,97	0,95	0,93	0,88	0,85
7	1,06	0,93	1,04	0,97	1,01	0,98	0,99	0,95	0,95	0,91	0,88	0,83
9	1,08	0,94	1,06	0,97	1,02	0,94	0,99	0,91	0,95	0,88	0,88	0,80
10	1,10	0,94	1,07	0,97	1,02	0,93	0,99	0,89	0,95	0,86	0,88	0,78
11	1,10	0,94	1,08	0,96	1,02	0,91	0,99	0,87	0,95	0,84	0,88	0,77
14	1,13	0,96	1,08	0,92	1,02	0,87	0,99	0,83	0,95	0,80	0,88	0,73
15	1,13	0,96	1,08	0,91	1,02	0,85	0,99	0,82	0,95	0,78	0,88	0,72

**RAS-18FSXN**

To\Ti	16		18		20		21		22		24	
	Q	P	Q	P	Q	P	Q	P	Q	P	Q	P
-20	0,52	0,83	0,52	0,88	0,52	0,92	0,52	0,95	0,51	0,97	0,51	1,02
-17	0,57	0,84	0,57	0,88	0,57	0,93	0,57	0,96	0,57	0,98	0,57	1,03
-15	0,61	0,85	0,61	0,89	0,61	0,94	0,61	0,96	0,61	0,98	0,61	1,03
-13	0,65	0,85	0,65	0,89	0,65	0,94	0,65	0,97	0,64	0,99	0,64	1,04
-11	0,68	0,85	0,68	0,90	0,68	0,94	0,68	0,97	0,68	0,99	0,68	1,04
-10	0,70	0,85	0,70	0,90	0,70	0,94	0,70	0,97	0,70	0,99	0,70	1,04
-9	0,72	0,86	0,72	0,90	0,72	0,95	0,72	0,98	0,72	1,00	0,72	1,05
-7	0,76	0,87	0,76	0,92	0,76	0,97	0,76	0,99	0,76	1,01	0,75	1,06
-6	0,78	0,88	0,78	0,93	0,78	0,98	0,78	1,00	0,78	1,02	0,77	1,07
-5	0,81	0,89	0,80	0,93	0,80	0,98	0,80	1,01	0,80	1,03	0,79	1,08
-3	0,85	0,91	0,84	0,95	0,84	1,00	0,84	1,02	0,84	1,05	0,82	1,09
-1	0,89	0,93	0,88	0,97	0,88	1,02	0,88	1,04	0,87	1,07	0,85	1,09
0	0,91	0,94	0,90	0,98	0,90	1,03	0,90	1,05	0,89	1,08	0,87	1,10
1	0,93	0,94	0,92	0,98	0,92	1,03	0,91	1,04	0,90	1,06	0,87	1,05
3	0,96	0,93	0,96	0,98	0,95	1,02	0,95	1,02	0,93	1,01	0,88	0,97
5	1,00	0,93	1,00	0,98	0,99	1,01	0,98	1,00	0,95	0,97	0,88	0,88
6	1,04	0,93	1,03	0,97	1,00	1,00	0,98	0,97	0,96	0,93	0,88	0,85
7	1,06	0,93	1,04	0,97	1,00	0,98	0,99	0,95	0,96	0,91	0,88	0,83
9	1,08	0,94	1,06	0,97	1,01	0,94	0,99	0,91	0,96	0,87	0,88	0,80
10	1,10	0,94	1,07	0,97	1,02	0,92	0,99	0,89	0,96	0,86	0,88	0,78
11	1,10	0,95	1,08	0,96	1,02	0,91	0,99	0,87	0,96	0,84	0,88	0,77
14	1,13	0,96	1,08	0,92	1,02	0,86	0,99	0,83	0,96	0,80	0,88	0,73
15	1,13	0,96	1,08	0,91	1,02	0,85	0,99	0,82	0,96	0,78	0,88	0,72

4

**RAS-20FSXN**

To\Ti	16		18		20		21		22		24	
	Q	P	Q	P	Q	P	Q	P	Q	P	Q	P
-20	0,51	0,87	0,51	0,92	0,51	0,96	0,51	0,98	0,51	1,01	0,51	1,06
-17	0,57	0,88	0,57	0,93	0,57	0,97	0,57	0,99	0,57	1,02	0,57	1,07
-15	0,61	0,89	0,61	0,94	0,61	0,98	0,61	1,00	0,61	1,03	0,60	1,08
-13	0,64	0,89	0,64	0,94	0,64	0,98	0,64	1,00	0,64	1,03	0,64	1,08
-11	0,68	0,89	0,68	0,94	0,68	0,98	0,68	1,01	0,68	1,04	0,67	1,08
-10	0,70	0,89	0,70	0,94	0,70	0,98	0,70	1,01	0,70	1,04	0,69	1,08
-9	0,72	0,90	0,72	0,95	0,72	0,99	0,72	1,01	0,72	1,04	0,71	1,09
-7	0,76	0,92	0,76	0,96	0,76	1,00	0,76	1,03	0,76	1,05	0,75	1,08
-6	0,78	0,93	0,78	0,97	0,78	1,01	0,78	1,03	0,78	1,06	0,76	1,08
-5	0,81	0,93	0,80	0,98	0,80	1,02	0,80	1,04	0,80	1,07	0,79	1,10
-3	0,85	0,96	0,85	0,99	0,84	1,03	0,84	1,05	0,84	1,07	0,82	1,08
-1	0,89	0,98	0,89	1,01	0,88	1,04	0,88	1,06	0,87	1,08	0,84	1,07
0	0,91	0,99	0,91	1,02	0,90	1,05	0,90	1,07	0,89	1,08	0,86	1,06
1	0,93	0,98	0,93	1,01	0,92	1,04	0,91	1,05	0,90	1,05	0,86	1,02
3	0,96	0,97	0,96	1,00	0,95	1,03	0,94	1,02	0,92	1,00	0,87	0,95
5	1,00	0,96	0,99	0,99	0,97	1,01	0,96	0,99	0,94	0,95	0,87	0,87
6	1,03	0,96	1,02	0,98	1,00	1,00	0,98	0,97	0,95	0,93	0,87	0,86
7	1,04	0,96	1,03	0,98	1,00	0,98	0,98	0,95	0,95	0,91	0,87	0,84
9	1,08	0,96	1,05	0,97	1,01	0,94	0,98	0,91	0,95	0,87	0,87	0,80
10	1,09	0,96	1,06	0,96	1,01	0,92	0,98	0,89	0,95	0,85	0,87	0,78
11	1,10	0,96	1,06	0,95	1,01	0,90	0,98	0,87	0,95	0,84	0,87	0,77
14	1,12	0,96	1,07	0,92	1,01	0,86	0,98	0,83	0,95	0,80	0,87	0,74
15	1,12	0,96	1,07	0,91	1,01	0,85	0,98	0,82	0,95	0,78	0,87	0,72

**RAS-22FSXN**

To\Ti	16		18		20		21		22		24	
	Q	P	Q	P	Q	P	Q	P	Q	P	Q	P
-20	0,55	0,93	0,55	0,97	0,55	1,02	0,55	1,05	0,55	1,07	0,55	1,12
-17	0,62	0,94	0,62	0,98	0,62	1,03	0,62	1,06	0,61	1,08	0,61	1,13
-15	0,66	0,94	0,66	0,99	0,66	1,04	0,66	1,06	0,65	1,09	0,65	1,14
-13	0,69	0,95	0,69	0,99	0,69	1,04	0,69	1,07	0,69	1,09	0,69	1,14
-11	0,73	0,95	0,73	0,99	0,73	1,05	0,73	1,07	0,73	1,09	0,73	1,14
-10	0,75	0,95	0,75	0,99	0,75	1,05	0,75	1,07	0,75	1,09	0,75	1,14
-9	0,77	0,95	0,77	1,00	0,77	1,05	0,77	1,07	0,77	1,10	0,77	1,14
-7	0,81	0,97	0,81	1,01	0,81	1,06	0,81	1,08	0,81	1,10	0,80	1,13
-6	0,83	0,97	0,83	1,02	0,83	1,06	0,83	1,08	0,82	1,10	0,81	1,12
-5	0,86	0,98	0,86	1,02	0,85	1,07	0,85	1,09	0,85	1,11	0,84	1,15
-3	0,90	0,99	0,89	1,03	0,89	1,07	0,89	1,09	0,88	1,11	0,86	1,11
-1	0,93	1,01	0,93	1,04	0,92	1,07	0,92	1,09	0,91	1,10	0,87	1,07
0	0,95	1,02	0,95	1,05	0,94	1,07	0,94	1,09	0,93	1,09	0,88	1,05
1	0,97	1,02	0,96	1,05	0,95	1,06	0,94	1,07	0,93	1,07	0,88	1,02
3	1,00	1,02	0,99	1,06	0,97	1,04	0,96	1,03	0,94	1,01	0,88	0,96
5	1,03	1,02	1,01	1,06	0,99	1,02	0,98	0,99	0,96	0,96	0,88	0,90
6	1,06	1,02	1,03	1,05	1,00	1,00	0,98	0,97	0,96	0,94	0,88	0,88
7	1,07	1,02	1,04	1,04	1,01	0,99	0,98	0,96	0,96	0,93	0,88	0,86
9	1,10	1,02	1,07	1,02	1,02	0,97	0,99	0,93	0,96	0,90	0,88	0,83
10	1,11	1,02	1,08	1,01	1,02	0,95	0,99	0,92	0,96	0,89	0,88	0,82
11	1,11	1,02	1,08	1,00	1,02	0,94	0,99	0,91	0,96	0,87	0,88	0,81
14	1,13	1,01	1,08	0,96	1,02	0,90	0,99	0,87	0,96	0,84	0,88	0,77
15	1,13	1,01	1,08	0,95	1,02	0,89	0,99	0,86	0,96	0,83	0,88	0,76

4

**RAS-24FSXN**

To\Ti	16		18		20		21		22		24	
	Q	P	Q	P	Q	P	Q	P	Q	P	Q	P
-20	0,52	0,86	0,52	0,90	0,52	0,95	0,52	0,97	0,52	1,00	0,52	1,04
-17	0,58	0,87	0,58	0,91	0,58	0,96	0,58	0,98	0,58	1,01	0,58	1,05
-15	0,62	0,88	0,62	0,92	0,62	0,97	0,62	0,99	0,62	1,01	0,62	1,06
-13	0,66	0,88	0,66	0,92	0,66	0,97	0,66	0,99	0,65	1,02	0,65	1,06
-11	0,69	0,88	0,69	0,92	0,69	0,97	0,69	1,00	0,69	1,02	0,69	1,07
-10	0,71	0,88	0,71	0,92	0,71	0,97	0,71	1,00	0,71	1,02	0,71	1,07
-9	0,73	0,89	0,73	0,93	0,73	0,98	0,73	1,00	0,73	1,02	0,73	1,07
-7	0,77	0,90	0,77	0,94	0,77	0,99	0,77	1,01	0,77	1,03	0,76	1,07
-6	0,79	0,90	0,79	0,95	0,79	0,99	0,79	1,01	0,78	1,04	0,78	1,06
-5	0,82	0,90	0,81	0,95	0,81	1,00	0,81	1,02	0,81	1,04	0,80	1,09
-3	0,85	0,92	0,85	0,96	0,85	1,00	0,84	1,03	0,84	1,05	0,83	1,07
-1	0,88	0,93	0,88	0,97	0,88	1,01	0,88	1,03	0,87	1,05	0,85	1,04
0	0,90	0,94	0,90	0,98	0,90	1,01	0,89	1,04	0,89	1,06	0,86	1,03
1	0,92	0,94	0,92	0,98	0,91	1,01	0,91	1,02	0,90	1,03	0,86	1,00
3	0,96	0,96	0,95	1,00	0,95	1,01	0,94	1,00	0,92	0,98	0,87	0,93
5	0,99	0,97	0,99	1,02	0,98	1,00	0,97	0,97	0,94	0,93	0,87	0,86
6	1,03	0,97	1,02	1,01	1,00	1,00	0,97	0,97	0,94	0,93	0,87	0,86
7	1,04	0,97	1,03	1,00	1,00	0,98	0,97	0,95	0,94	0,91	0,87	0,82
9	1,07	0,97	1,05	0,98	1,00	0,94	0,98	0,91	0,94	0,87	0,87	0,76
10	1,08	0,97	1,06	0,97	1,01	0,92	0,98	0,89	0,94	0,85	0,87	0,72
11	1,09	0,96	1,06	0,96	1,01	0,91	0,98	0,87	0,94	0,84	0,87	0,72
14	1,11	0,96	1,07	0,92	1,01	0,87	0,98	0,83	0,94	0,80	0,87	0,72
15	1,12	0,96	1,07	0,91	1,01	0,85	0,98	0,82	0,94	0,79	0,87	0,72



**RAS-26FSXN**

To\Ti	16		18		20		21		22		24	
	Q	P	Q	P	Q	P	Q	P	Q	P	Q	P
-20	0,51	0,86	0,51	0,90	0,51	0,95	0,51	0,97	0,51	1,00	0,50	1,05
-17	0,56	0,87	0,56	0,91	0,56	0,96	0,56	0,98	0,56	1,01	0,56	1,06
-15	0,60	0,87	0,60	0,92	0,60	0,96	0,60	0,99	0,60	1,01	0,60	1,06
-13	0,64	0,88	0,64	0,92	0,64	0,97	0,64	0,99	0,63	1,02	0,63	1,07
-11	0,67	0,88	0,67	0,92	0,67	0,97	0,67	0,99	0,67	1,02	0,67	1,07
-10	0,69	0,88	0,69	0,92	0,69	0,97	0,69	0,99	0,69	1,02	0,68	1,07
-9	0,71	0,88	0,71	0,93	0,71	0,97	0,71	1,00	0,71	1,02	0,70	1,07
-7	0,75	0,90	0,75	0,94	0,75	0,99	0,75	1,01	0,75	1,04	0,74	1,08
-6	0,77	0,90	0,77	0,95	0,77	0,99	0,77	1,02	0,77	1,04	0,76	1,08
-5	0,80	0,91	0,80	0,95	0,80	1,00	0,80	1,03	0,79	1,05	0,79	1,10
-3	0,84	0,92	0,84	0,97	0,84	1,01	0,83	1,04	0,83	1,06	0,82	1,09
-1	0,88	0,94	0,88	0,98	0,88	1,03	0,87	1,05	0,87	1,07	0,85	1,07
0	0,90	0,95	0,90	0,99	0,90	1,03	0,89	1,05	0,89	1,08	0,86	1,06
1	0,92	0,95	0,92	0,99	0,92	1,03	0,91	1,04	0,90	1,05	0,87	1,02
3	0,96	0,95	0,97	0,99	0,96	1,01	0,95	1,02	0,93	0,99	0,87	0,94
5	1,00	0,96	1,02	1,00	1,00	1,00	0,98	1,00	0,96	0,93	0,88	0,85
6	1,03	0,96	1,02	1,00	1,00	1,00	0,98	0,97	0,96	0,93	0,88	0,85
7	1,05	0,96	1,03	1,00	1,01	0,98	0,99	0,95	0,96	0,91	0,88	0,84
9	1,07	0,97	1,05	0,99	1,02	0,95	0,99	0,92	0,96	0,88	0,88	0,81
10	1,09	0,97	1,07	0,98	1,02	0,93	0,99	0,90	0,96	0,86	0,88	0,79
11	1,10	0,97	1,07	0,97	1,02	0,92	0,99	0,88	0,96	0,85	0,88	0,78
14	1,12	0,97	1,08	0,93	1,02	0,87	0,99	0,84	0,96	0,81	0,88	0,74
15	1,13	0,97	1,08	0,92	1,02	0,86	0,99	0,83	0,96	0,79	0,88	0,73

4

**RAS-28FSXN**

To\Ti	16		18		20		21		22		24	
	Q	P	Q	P	Q	P	Q	P	Q	P	Q	P
-20	0,53	0,88	0,53	0,92	0,53	0,97	0,53	1,00	0,53	1,02	0,53	1,07
-17	0,59	0,89	0,59	0,93	0,59	0,98	0,59	1,01	0,59	1,03	0,59	1,08
-15	0,63	0,90	0,63	0,94	0,63	0,99	0,63	1,01	0,63	1,04	0,62	1,08
-13	0,66	0,90	0,66	0,94	0,66	0,99	0,66	1,02	0,66	1,04	0,66	1,09
-11	0,70	0,90	0,70	0,94	0,70	0,99	0,70	1,02	0,70	1,04	0,70	1,09
-10	0,72	0,90	0,72	0,94	0,72	0,99	0,72	1,02	0,72	1,04	0,72	1,09
-9	0,74	0,91	0,74	0,95	0,74	1,00	0,74	1,02	0,74	1,05	0,74	1,09
-7	0,78	0,92	0,78	0,96	0,78	1,01	0,78	1,03	0,78	1,05	0,77	1,09
-6	0,80	0,92	0,80	0,96	0,80	1,01	0,80	1,03	0,79	1,06	0,78	1,08
-5	0,83	0,92	0,82	0,97	0,82	1,02	0,82	1,04	0,82	1,06	0,81	1,12
-3	0,86	0,93	0,86	0,98	0,86	1,02	0,85	1,05	0,85	1,07	0,84	1,08
-1	0,90	0,94	0,89	0,99	0,89	1,03	0,89	1,05	0,88	1,07	0,86	1,05
0	0,91	0,95	0,91	0,99	0,91	1,03	0,91	1,06	0,90	1,07	0,87	1,03
1	0,93	0,95	0,93	1,00	0,93	1,03	0,92	1,04	0,91	1,05	0,87	1,00
3	0,97	0,97	0,96	1,01	0,96	1,02	0,95	1,02	0,93	1,00	0,88	0,94
5	1,01	0,98	1,00	1,03	0,99	1,02	0,98	0,99	0,95	0,95	0,88	0,88
6	1,05	0,98	1,03	1,03	1,00	1,00	0,98	0,97	0,95	0,93	0,88	0,86
7	1,06	0,99	1,04	1,02	1,01	0,99	0,99	0,95	0,95	0,92	0,88	0,84
9	1,08	0,99	1,06	1,00	1,02	0,96	0,99	0,92	0,95	0,89	0,88	0,81
10	1,10	0,99	1,07	0,99	1,02	0,94	0,99	0,91	0,95	0,87	0,88	0,80
11	1,10	0,99	1,08	0,98	1,02	0,93	0,99	0,89	0,95	0,86	0,88	0,79
14	1,13	0,98	1,08	0,94	1,02	0,89	0,99	0,85	0,95	0,82	0,88	0,75
15	1,13	0,98	1,08	0,93	1,02	0,87	0,99	0,84	0,95	0,80	0,88	0,74

**RAS-30FSXN**

To\Ti	16		18		20		21		22		24	
	Q	P	Q	P	Q	P	Q	P	Q	P	Q	P
-20	0,52	0,85	0,52	0,90	0,52	0,94	0,52	0,97	0,52	0,99	0,52	1,04
-17	0,58	0,86	0,58	0,91	0,58	0,95	0,58	0,98	0,58	1,00	0,58	1,05
-15	0,62	0,87	0,62	0,91	0,62	0,96	0,62	0,98	0,62	1,01	0,61	1,06
-13	0,65	0,87	0,65	0,91	0,65	0,96	0,65	0,99	0,65	1,01	0,65	1,06
-11	0,69	0,87	0,69	0,92	0,69	0,96	0,69	0,99	0,69	1,02	0,69	1,06
-10	0,71	0,87	0,71	0,92	0,71	0,96	0,71	0,99	0,71	1,02	0,71	1,06
-9	0,73	0,88	0,73	0,92	0,73	0,97	0,73	0,99	0,73	1,02	0,72	1,07
-7	0,77	0,89	0,77	0,94	0,77	0,98	0,77	1,01	0,77	1,03	0,76	1,07
-6	0,79	0,90	0,79	0,94	0,79	0,99	0,79	1,01	0,78	1,04	0,78	1,07
-5	0,82	0,90	0,81	0,95	0,81	1,00	0,81	1,02	0,81	1,05	0,80	1,10
-3	0,85	0,92	0,85	0,96	0,85	1,01	0,85	1,03	0,84	1,06	0,83	1,08
-1	0,89	0,94	0,89	0,98	0,89	1,02	0,88	1,05	0,88	1,07	0,86	1,07
0	0,91	0,94	0,91	0,98	0,91	1,03	0,90	1,06	0,90	1,08	0,87	1,07
1	0,93	0,95	0,93	0,99	0,92	1,03	0,92	1,04	0,91	1,05	0,87	1,03
3	0,97	0,95	0,96	1,00	0,96	1,02	0,95	1,02	0,93	1,01	0,88	0,96
5	1,01	0,95	1,00	1,00	0,99	1,02	0,98	1,00	0,95	0,96	0,88	0,88
6	1,05	0,96	1,03	1,00	1,00	1,00	0,98	0,97	0,95	0,93	0,88	0,86
7	1,06	0,96	1,04	0,99	1,01	0,98	0,99	0,95	0,95	0,91	0,88	0,84
9	1,08	0,96	1,06	0,98	1,02	0,95	0,99	0,91	0,95	0,88	0,88	0,81
10	1,10	0,96	1,07	0,98	1,02	0,93	0,99	0,90	0,95	0,86	0,88	0,79
11	1,10	0,96	1,07	0,97	1,02	0,92	0,99	0,88	0,95	0,85	0,88	0,78
14	1,13	0,97	1,08	0,93	1,02	0,87	0,99	0,84	0,95	0,81	0,88	0,74
15	1,13	0,97	1,08	0,92	1,02	0,86	0,99	0,83	0,95	0,79	0,88	0,73

4

**RAS-32FSXN**

To\Ti	16		18		20		21		22		24	
	Q	P	Q	P	Q	P	Q	P	Q	P	Q	P
-20	0,52	0,83	0,52	0,88	0,52	0,92	0,52	0,95	0,51	0,97	0,51	1,02
-17	0,57	0,84	0,57	0,88	0,57	0,93	0,57	0,95	0,57	0,98	0,57	1,03
-15	0,61	0,85	0,61	0,89	0,61	0,94	0,61	0,96	0,61	0,98	0,61	1,04
-13	0,65	0,85	0,65	0,89	0,65	0,94	0,65	0,96	0,64	0,99	0,64	1,04
-11	0,68	0,85	0,68	0,90	0,68	0,94	0,68	0,97	0,68	0,99	0,68	1,04
-10	0,70	0,85	0,70	0,90	0,70	0,94	0,70	0,97	0,70	0,99	0,70	1,04
-9	0,72	0,86	0,72	0,90	0,72	0,95	0,72	0,97	0,72	1,00	0,72	1,05
-7	0,76	0,88	0,76	0,92	0,76	0,97	0,76	0,99	0,76	1,01	0,75	1,06
-6	0,78	0,89	0,78	0,93	0,78	0,97	0,78	1,00	0,78	1,02	0,77	1,07
-5	0,81	0,89	0,80	0,94	0,80	0,98	0,80	1,00	0,80	1,03	0,79	1,08
-3	0,85	0,91	0,84	0,95	0,84	1,00	0,84	1,02	0,84	1,05	0,82	1,09
-1	0,89	0,93	0,88	0,97	0,88	1,02	0,88	1,05	0,87	1,07	0,85	1,10
0	0,91	0,94	0,90	0,98	0,90	1,03	0,90	1,06	0,89	1,08	0,87	1,10
1	0,93	0,94	0,92	0,98	0,92	1,03	0,91	1,04	0,90	1,06	0,87	1,06
3	0,96	0,93	0,96	0,98	0,95	1,02	0,94	1,02	0,93	1,01	0,88	0,97
5	1,00	0,93	1,00	0,98	0,99	1,01	0,98	1,00	0,95	0,97	0,88	0,88
6	1,04	0,93	1,03	0,97	1,00	1,00	0,98	0,97	0,96	0,93	0,88	0,85
7	1,06	0,93	1,04	0,97	1,01	0,98	0,99	0,95	0,96	0,91	0,88	0,83
9	1,08	0,94	1,06	0,97	1,02	0,94	0,99	0,91	0,96	0,87	0,88	0,80
10	1,10	0,94	1,07	0,97	1,02	0,92	0,99	0,89	0,96	0,85	0,88	0,78
11	1,10	0,94	1,08	0,96	1,02	0,91	0,99	0,88	0,96	0,84	0,88	0,77
14	1,13	0,96	1,08	0,92	1,02	0,86	0,99	0,83	0,96	0,80	0,88	0,73
15	1,13	0,96	1,08	0,91	1,02	0,85	0,99	0,82	0,96	0,78	0,88	0,72

**RAS-34FSXN**

To\Ti	16		18		20		21		22		24	
	Q	P	Q	P	Q	P	Q	P	Q	P	Q	P
-20	0,52	0,83	0,52	0,88	0,52	0,92	0,52	0,94	0,51	0,97	0,51	1,02
-17	0,57	0,84	0,57	0,88	0,57	0,93	0,57	0,95	0,57	0,98	0,57	1,03
-15	0,61	0,85	0,61	0,89	0,61	0,94	0,61	0,96	0,61	0,98	0,61	1,03
-13	0,65	0,85	0,65	0,89	0,65	0,94	0,65	0,96	0,64	0,99	0,64	1,04
-11	0,68	0,85	0,68	0,90	0,68	0,94	0,68	0,97	0,68	0,99	0,68	1,04
-10	0,70	0,85	0,70	0,90	0,70	0,94	0,70	0,97	0,70	0,99	0,70	1,04
-9	0,72	0,86	0,72	0,90	0,72	0,95	0,72	0,97	0,72	1,00	0,72	1,05
-7	0,76	0,88	0,76	0,92	0,76	0,97	0,76	0,99	0,76	1,02	0,75	1,06
-6	0,78	0,88	0,78	0,93	0,78	0,97	0,78	1,00	0,78	1,02	0,77	1,07
-5	0,81	0,89	0,80	0,93	0,80	0,98	0,80	1,00	0,80	1,03	0,79	1,08
-3	0,85	0,91	0,84	0,95	0,84	1,00	0,84	1,02	0,84	1,05	0,82	1,09
-1	0,89	0,93	0,88	0,97	0,88	1,02	0,88	1,05	0,87	1,07	0,85	1,10
0	0,91	0,94	0,90	0,98	0,90	1,03	0,90	1,06	0,89	1,08	0,87	1,10
1	0,93	0,94	0,92	0,98	0,92	1,03	0,91	1,04	0,90	1,06	0,87	1,06
3	0,96	0,93	0,96	0,98	0,95	1,02	0,95	1,02	0,93	1,01	0,88	0,97
5	1,00	0,93	1,00	0,98	0,99	1,01	0,98	1,00	0,95	0,97	0,88	0,88
6	1,04	0,93	1,03	0,97	1,00	1,00	0,98	0,97	0,95	0,93	0,88	0,85
7	1,06	0,93	1,04	0,97	1,00	0,98	0,99	0,95	0,95	0,91	0,88	0,83
9	1,08	0,94	1,06	0,97	1,01	0,94	0,99	0,91	0,95	0,87	0,88	0,80
10	1,10	0,94	1,07	0,97	1,02	0,92	0,99	0,89	0,95	0,85	0,88	0,78
11	1,10	0,94	1,07	0,96	1,02	0,91	0,99	0,87	0,95	0,84	0,88	0,77
14	1,13	0,96	1,08	0,92	1,02	0,86	0,99	0,83	0,95	0,80	0,88	0,73
15	1,13	0,96	1,08	0,91	1,02	0,85	0,99	0,82	0,95	0,78	0,88	0,72

4

**RAS-36FSXN**

To\Ti	16		18		20		21		22		24	
	Q	P	Q	P	Q	P	Q	P	Q	P	Q	P
-20	0,52	0,83	0,52	0,88	0,52	0,92	0,52	0,94	0,51	0,97	0,51	1,02
-17	0,57	0,84	0,57	0,88	0,57	0,93	0,57	0,95	0,57	0,98	0,57	1,03
-15	0,61	0,85	0,61	0,89	0,61	0,94	0,61	0,96	0,61	0,98	0,61	1,03
-13	0,65	0,85	0,65	0,89	0,65	0,94	0,65	0,96	0,64	0,99	0,64	1,04
-11	0,68	0,85	0,68	0,90	0,68	0,94	0,68	0,96	0,68	0,99	0,68	1,04
-10	0,70	0,85	0,70	0,90	0,70	0,94	0,70	0,96	0,70	0,99	0,70	1,04
-9	0,72	0,86	0,72	0,90	0,72	0,95	0,72	0,97	0,72	1,00	0,72	1,05
-7	0,76	0,87	0,76	0,92	0,76	0,97	0,76	0,99	0,76	1,02	0,75	1,06
-6	0,78	0,88	0,78	0,93	0,78	0,97	0,78	1,00	0,78	1,02	0,77	1,07
-5	0,81	0,89	0,80	0,93	0,80	0,98	0,80	1,01	0,80	1,03	0,79	1,08
-3	0,85	0,91	0,84	0,95	0,84	1,00	0,84	1,03	0,84	1,05	0,82	1,09
-1	0,89	0,93	0,88	0,97	0,88	1,02	0,88	1,05	0,87	1,07	0,85	1,10
0	0,91	0,94	0,90	0,98	0,90	1,03	0,90	1,06	0,89	1,08	0,87	1,10
1	0,93	0,94	0,92	0,98	0,92	1,03	0,91	1,04	0,90	1,06	0,87	1,06
3	0,96	0,94	0,96	0,98	0,95	1,02	0,94	1,02	0,93	1,01	0,88	0,97
5	1,00	0,93	1,00	0,98	0,99	1,01	0,98	1,00	0,95	0,96	0,88	0,88
6	1,04	0,93	1,03	0,97	1,00	1,00	0,98	0,97	0,95	0,93	0,88	0,85
7	1,06	0,93	1,04	0,97	1,00	0,98	0,99	0,95	0,95	0,91	0,88	0,83
9	1,08	0,94	1,06	0,97	1,01	0,94	0,99	0,91	0,95	0,88	0,88	0,80
10	1,10	0,94	1,07	0,97	1,02	0,92	0,99	0,89	0,95	0,86	0,88	0,78
11	1,10	0,95	1,08	0,96	1,02	0,91	0,99	0,87	0,95	0,84	0,88	0,77
14	1,13	0,96	1,08	0,92	1,02	0,86	0,99	0,83	0,95	0,80	0,88	0,73
15	1,13	0,96	1,08	0,91	1,02	0,85	0,99	0,82	0,95	0,78	0,88	0,72

**RAS-38FSXN**

To\Ti	16		18		20		21		22		24	
	Q	P	Q	P	Q	P	Q	P	Q	P	Q	P
-20	0,51	0,88	0,51	0,92	0,51	0,97	0,51	0,99	0,51	1,02	0,50	1,07
-17	0,56	0,89	0,56	0,93	0,56	0,98	0,56	1,00	0,56	1,03	0,56	1,08
-15	0,60	0,89	0,60	0,94	0,60	0,98	0,60	1,01	0,60	1,04	0,60	1,09
-13	0,63	0,90	0,63	0,94	0,63	0,99	0,63	1,01	0,63	1,04	0,63	1,09
-11	0,67	0,90	0,67	0,94	0,67	0,99	0,67	1,02	0,67	1,04	0,67	1,09
-10	0,69	0,90	0,69	0,94	0,69	0,99	0,69	1,02	0,69	1,04	0,68	1,09
-9	0,71	0,90	0,71	0,95	0,71	1,00	0,71	1,02	0,71	1,05	0,71	1,10
-7	0,76	0,92	0,75	0,96	0,75	1,01	0,75	1,04	0,75	1,06	0,74	1,11
-6	0,78	0,93	0,78	0,97	0,78	1,02	0,78	1,05	0,77	1,07	0,76	1,11
-5	0,80	0,94	0,80	0,98	0,80	1,03	0,80	1,05	0,80	1,08	0,79	1,13
-3	0,84	0,95	0,84	0,99	0,84	1,04	0,84	1,07	0,84	1,09	0,82	1,12
-1	0,89	0,97	0,89	1,01	0,89	1,06	0,88	1,08	0,88	1,11	0,86	1,11
0	0,91	0,97	0,91	1,02	0,91	1,06	0,90	1,09	0,90	1,11	0,87	1,11
1	0,93	0,97	0,93	1,01	0,92	1,05	0,92	1,07	0,91	1,08	0,87	1,06
3	0,96	0,97	0,96	1,01	0,96	1,04	0,95	1,03	0,93	1,01	0,88	0,97
5	1,00	0,96	1,00	1,01	0,99	1,02	0,98	0,99	0,96	0,95	0,88	0,87
6	1,03	0,95	1,02	0,99	1,00	1,00	0,98	0,97	0,96	0,93	0,88	0,86
7	1,04	0,96	1,03	0,99	1,01	0,98	0,98	0,95	0,96	0,92	0,88	0,84
9	1,08	0,96	1,06	0,99	1,02	0,95	0,99	0,92	0,96	0,88	0,88	0,81
10	1,10	0,97	1,07	0,99	1,02	0,94	0,99	0,90	0,96	0,86	0,88	0,79
11	1,10	0,97	1,07	0,97	1,02	0,92	0,99	0,89	0,96	0,85	0,88	0,78
14	1,13	0,98	1,08	0,94	1,02	0,88	0,99	0,84	0,96	0,81	0,88	0,74
15	1,13	0,98	1,08	0,92	1,02	0,86	0,99	0,83	0,96	0,79	0,88	0,73

**RAS-40FSXN**

To\Ti	16		18		20		21		22		24	
	Q	P	Q	P	Q	P	Q	P	Q	P	Q	P
-20	0,49	0,83	0,49	0,88	0,49	0,92	0,49	0,94	0,49	0,97	0,49	1,02
-17	0,55	0,84	0,55	0,89	0,55	0,93	0,55	0,95	0,55	0,98	0,55	1,03
-15	0,58	0,84	0,58	0,89	0,58	0,94	0,58	0,96	0,58	0,99	0,58	1,04
-13	0,62	0,85	0,62	0,89	0,62	0,94	0,62	0,96	0,62	0,99	0,61	1,04
-11	0,65	0,85	0,65	0,90	0,65	0,94	0,65	0,96	0,65	0,99	0,65	1,04
-10	0,67	0,85	0,67	0,90	0,67	0,94	0,67	0,96	0,67	0,99	0,67	1,04
-9	0,69	0,86	0,69	0,90	0,69	0,95	0,69	0,97	0,69	1,00	0,69	1,05
-7	0,74	0,88	0,74	0,92	0,74	0,97	0,74	0,99	0,73	1,02	0,73	1,06
-6	0,76	0,89	0,76	0,93	0,76	0,98	0,76	1,00	0,75	1,03	0,75	1,07
-5	0,78	0,89	0,78	0,94	0,78	0,98	0,78	1,01	0,78	1,03	0,77	1,08
-3	0,83	0,91	0,82	0,95	0,82	1,00	0,82	1,03	0,82	1,05	0,81	1,09
-1	0,87	0,93	0,87	0,97	0,87	1,02	0,86	1,05	0,86	1,07	0,84	1,10
0	0,89	0,94	0,89	0,98	0,89	1,03	0,89	1,06	0,88	1,08	0,86	1,10
1	0,91	0,94	0,91	0,98	0,91	1,03	0,90	1,04	0,89	1,06	0,86	1,06
3	0,95	0,93	0,95	0,98	0,94	1,02	0,94	1,02	0,92	1,01	0,87	0,97
5	0,99	0,93	0,99	0,98	0,98	1,01	0,97	1,00	0,95	0,96	0,88	0,88
6	1,03	0,93	1,02	0,97	1,00	1,00	0,98	0,97	0,95	0,93	0,88	0,85
7	1,04	0,93	1,03	0,97	1,01	0,98	0,99	0,95	0,95	0,91	0,88	0,83
9	1,07	0,94	1,05	0,97	1,02	0,94	0,99	0,91	0,95	0,87	0,88	0,80
10	1,09	0,94	1,06	0,97	1,02	0,92	0,99	0,89	0,95	0,86	0,88	0,78
11	1,10	0,94	1,07	0,96	1,02	0,91	0,99	0,88	0,95	0,84	0,88	0,77
14	1,12	0,96	1,08	0,92	1,02	0,86	0,99	0,83	0,95	0,80	0,88	0,73
15	1,13	0,96	1,08	0,91	1,02	0,85	0,99	0,82	0,95	0,78	0,88	0,72



**RAS-42FSXN**

To\Ti	16		18		20		21		22		24	
	Q	P	Q	P	Q	P	Q	P	Q	P	Q	P
-20	0,49	0,83	0,49	0,88	0,49	0,92	0,49	0,94	0,49	0,97	0,49	1,01
-17	0,55	0,84	0,55	0,88	0,55	0,93	0,55	0,95	0,54	0,97	0,54	1,02
-15	0,58	0,84	0,58	0,89	0,58	0,93	0,58	0,96	0,58	0,98	0,58	1,03
-13	0,62	0,85	0,62	0,89	0,62	0,94	0,62	0,96	0,61	0,98	0,61	1,03
-11	0,65	0,85	0,65	0,90	0,65	0,94	0,65	0,96	0,65	0,99	0,64	1,04
-10	0,67	0,85	0,67	0,90	0,67	0,94	0,67	0,96	0,66	0,99	0,66	1,04
-9	0,69	0,86	0,69	0,90	0,69	0,95	0,69	0,97	0,69	1,00	0,68	1,04
-7	0,73	0,88	0,73	0,92	0,73	0,96	0,73	0,99	0,73	1,01	0,72	1,06
-6	0,75	0,88	0,75	0,93	0,75	0,97	0,75	1,00	0,75	1,02	0,74	1,06
-5	0,78	0,89	0,78	0,94	0,78	0,98	0,77	1,01	0,77	1,03	0,77	1,08
-3	0,82	0,91	0,82	0,95	0,82	1,00	0,82	1,02	0,81	1,05	0,80	1,09
-1	0,86	0,93	0,86	0,97	0,86	1,02	0,86	1,04	0,85	1,07	0,83	1,09
0	0,88	0,94	0,88	0,98	0,88	1,03	0,88	1,05	0,88	1,08	0,85	1,10
1	0,90	0,94	0,90	0,98	0,90	1,02	0,90	1,04	0,89	1,05	0,86	1,05
3	0,94	0,94	0,94	0,98	0,94	1,01	0,93	1,01	0,91	0,99	0,86	0,95
5	0,98	0,94	0,98	0,98	0,97	1,01	0,96	0,98	0,94	0,94	0,87	0,86
6	1,02	0,93	1,01	0,97	1,00	0,98	0,98	0,95	0,95	0,93	0,87	0,85
7	1,03	0,93	1,02	0,97	1,00	0,98	0,98	0,95	0,95	0,91	0,87	0,83
9	1,06	0,93	1,04	0,96	1,01	0,93	0,98	0,90	0,95	0,86	0,87	0,79
10	1,08	0,93	1,06	0,95	1,01	0,91	0,98	0,88	0,95	0,84	0,87	0,77
11	1,09	0,93	1,06	0,94	1,01	0,89	0,98	0,86	0,95	0,83	0,87	0,76
14	1,12	0,94	1,07	0,90	1,01	0,85	0,98	0,82	0,95	0,79	0,87	0,72
15	1,13	0,94	1,08	0,89	1,01	0,83	0,98	0,80	0,95	0,77	0,87	0,71

4

**RAS-44FSXN**

To\Ti	16		18		20		21		22		24	
	Q	P	Q	P	Q	P	Q	P	Q	P	Q	P
-20	0,51	0,83	0,51	0,88	0,51	0,92	0,51	0,95	0,50	0,97	0,50	1,02
-17	0,56	0,84	0,56	0,89	0,56	0,93	0,56	0,95	0,56	0,98	0,56	1,03
-15	0,60	0,85	0,60	0,89	0,60	0,94	0,60	0,96	0,60	0,98	0,59	1,03
-13	0,63	0,85	0,63	0,90	0,63	0,94	0,63	0,96	0,63	0,99	0,63	1,04
-11	0,67	0,85	0,67	0,90	0,67	0,94	0,67	0,97	0,67	0,99	0,66	1,04
-10	0,69	0,85	0,69	0,90	0,69	0,94	0,69	0,97	0,68	0,99	0,68	1,04
-9	0,71	0,86	0,71	0,90	0,71	0,95	0,71	0,97	0,70	1,00	0,70	1,05
-7	0,75	0,88	0,75	0,92	0,75	0,96	0,75	0,99	0,74	1,01	0,74	1,05
-6	0,77	0,88	0,77	0,93	0,77	0,97	0,77	0,99	0,76	1,02	0,76	1,06
-5	0,79	0,89	0,79	0,93	0,79	0,98	0,79	1,00	0,79	1,03	0,78	1,07
-3	0,83	0,91	0,83	0,95	0,83	0,99	0,83	1,01	0,82	1,04	0,81	1,07
-1	0,87	0,92	0,87	0,96	0,87	1,01	0,87	1,03	0,86	1,05	0,84	1,06
0	0,89	0,93	0,89	0,97	0,89	1,01	0,89	1,04	0,88	1,06	0,86	1,06
1	0,91	0,93	0,91	0,97	0,91	1,01	0,90	1,03	0,89	1,04	0,86	1,02
3	0,95	0,94	0,95	0,98	0,94	1,01	0,93	1,01	0,91	1,00	0,86	0,95
5	0,99	0,95	0,98	0,99	0,97	1,01	0,96	1,00	0,94	0,96	0,87	0,88
6	1,03	0,94	1,02	0,99	1,00	1,00	0,98	0,97	0,94	0,93	0,87	0,86
7	1,04	0,94	1,03	0,98	1,00	0,98	0,98	0,95	0,94	0,91	0,87	0,83
9	1,07	0,94	1,05	0,96	1,01	0,93	0,98	0,90	0,94	0,86	0,87	0,79
10	1,08	0,94	1,06	0,96	1,01	0,91	0,98	0,88	0,94	0,84	0,87	0,77
11	1,09	0,94	1,06	0,94	1,01	0,89	0,98	0,86	0,94	0,83	0,87	0,76
14	1,11	0,94	1,07	0,91	1,01	0,85	0,98	0,82	0,94	0,79	0,87	0,72
15	1,12	0,94	1,07	0,89	1,01	0,84	0,98	0,81	0,94	0,77	0,87	0,71

**RAS-46FSXN**

To\Ti	16		18		20		21		22		24	
	Q	P	Q	P	Q	P	Q	P	Q	P	Q	P
-20	0,50	0,83	0,50	0,87	0,50	0,92	0,50	0,94	0,50	0,96	0,50	1,01
-17	0,56	0,84	0,56	0,88	0,56	0,93	0,56	0,95	0,55	0,97	0,55	1,02
-15	0,59	0,84	0,59	0,89	0,59	0,93	0,59	0,95	0,59	0,98	0,59	1,03
-13	0,63	0,85	0,63	0,89	0,63	0,94	0,63	0,96	0,63	0,98	0,62	1,03
-11	0,66	0,85	0,66	0,89	0,66	0,94	0,66	0,96	0,66	0,99	0,66	1,04
-10	0,68	0,85	0,68	0,89	0,68	0,94	0,68	0,96	0,68	0,98	0,68	1,04
-9	0,70	0,86	0,70	0,90	0,70	0,95	0,70	0,97	0,70	0,99	0,70	1,04
-7	0,74	0,87	0,74	0,92	0,74	0,96	0,74	0,98	0,74	1,01	0,73	1,06
-6	0,76	0,88	0,76	0,92	0,76	0,97	0,76	0,99	0,76	1,02	0,75	1,06
-5	0,79	0,89	0,79	0,93	0,78	0,98	0,78	1,00	0,78	1,03	0,78	1,08
-3	0,83	0,91	0,83	0,95	0,83	1,00	0,82	1,02	0,82	1,04	0,81	1,08
-1	0,87	0,93	0,87	0,97	0,87	1,02	0,86	1,04	0,86	1,06	0,84	1,09
0	0,89	0,94	0,89	0,97	0,89	1,03	0,88	1,05	0,88	1,07	0,85	1,09
1	0,91	0,94	0,91	0,98	0,90	1,02	0,90	1,04	0,89	1,05	0,86	1,05
3	0,95	0,94	0,94	0,98	0,94	1,02	0,93	1,01	0,91	1,00	0,86	0,96
5	0,99	0,93	0,98	0,98	0,97	1,01	0,96	0,99	0,94	0,95	0,87	0,88
6	1,03	0,93	1,01	0,97	1,00	1,00	0,98	0,97	0,94	0,93	0,87	0,86
7	1,04	0,93	1,02	0,96	1,00	0,98	0,98	0,94	0,94	0,91	0,87	0,84
9	1,07	0,92	1,05	0,95	1,01	0,93	0,98	0,89	0,94	0,86	0,87	0,79
10	1,08	0,92	1,06	0,95	1,01	0,90	0,98	0,87	0,94	0,84	0,87	0,77
11	1,09	0,92	1,06	0,94	1,01	0,89	0,98	0,86	0,94	0,82	0,87	0,75
14	1,11	0,93	1,07	0,90	1,01	0,85	0,98	0,81	0,94	0,78	0,87	0,72
15	1,12	0,94	1,07	0,89	1,01	0,83	0,98	0,80	0,94	0,77	0,87	0,70

4

**RAS-48FSXN**

To\Ti	16		18		20		21		22		24	
	Q	P	Q	P	Q	P	Q	P	Q	P	Q	P
-20	0,51	0,83	0,51	0,87	0,51	0,91	0,51	0,94	0,50	0,96	0,50	1,01
-17	0,56	0,83	0,56	0,88	0,56	0,92	0,56	0,95	0,56	0,97	0,56	1,02
-15	0,60	0,84	0,60	0,88	0,60	0,93	0,60	0,95	0,60	0,98	0,59	1,03
-13	0,63	0,84	0,63	0,89	0,63	0,93	0,63	0,96	0,63	0,98	0,63	1,03
-11	0,67	0,84	0,67	0,89	0,67	0,93	0,67	0,96	0,67	0,98	0,66	1,03
-10	0,69	0,84	0,69	0,89	0,69	0,93	0,69	0,96	0,68	0,98	0,68	1,03
-9	0,71	0,85	0,71	0,90	0,71	0,94	0,71	0,97	0,70	0,99	0,70	1,04
-7	0,75	0,87	0,75	0,91	0,75	0,96	0,75	0,98	0,74	1,01	0,74	1,05
-6	0,77	0,88	0,77	0,92	0,77	0,97	0,77	0,99	0,76	1,02	0,76	1,06
-5	0,79	0,89	0,79	0,93	0,79	0,97	0,79	1,00	0,79	1,02	0,78	1,07
-3	0,83	0,91	0,83	0,95	0,83	0,99	0,83	1,02	0,83	1,04	0,81	1,08
-1	0,88	0,92	0,87	0,96	0,87	1,01	0,87	1,04	0,87	1,06	0,84	1,09
0	0,90	0,93	0,89	0,97	0,89	1,02	0,89	1,05	0,88	1,07	0,86	1,09
1	0,92	0,93	0,91	0,97	0,91	1,02	0,91	1,04	0,90	1,05	0,86	1,05
3	0,96	0,93	0,95	0,98	0,95	1,01	0,94	1,02	0,92	1,00	0,87	0,96
5	1,00	0,93	0,99	0,98	0,98	1,01	0,97	1,00	0,94	0,96	0,88	0,88
6	1,03	0,93	1,02	0,97	1,00	0,98	0,98	0,95	0,95	0,91	0,88	0,83
7	1,05	0,93	1,03	0,97	1,01	0,94	0,98	0,91	0,95	0,87	0,88	0,80
9	1,07	0,93	1,05	0,97	1,02	0,91	0,99	0,88	0,95	0,85	0,88	0,78
10	1,09	0,93	1,07	0,96	1,02	0,90	0,99	0,87	0,95	0,84	0,88	0,77
11	1,10	0,94	1,07	0,95	1,02	0,86	0,99	0,83	0,95	0,79	0,88	0,73
14	1,12	0,95	1,08	0,91	1,02	0,84	0,99	0,81	0,95	0,78	0,88	0,72
15	1,13	0,95	1,08	0,90	1,02							

**RAS-50FSXN**

To\Ti	16		18		20		21		22		24	
	Q	P	Q	P	Q	P	Q	P	Q	P	Q	P
-20	0,53	0,86	0,53	0,91	0,53	0,96	0,53	0,98	0,53	0,27	0,52	1,06
-17	0,59	0,87	0,59	0,92	0,59	0,97	0,59	0,99	0,58	0,27	0,58	1,07
-15	0,62	0,88	0,62	0,92	0,62	0,97	0,62	1,00	0,62	0,27	0,62	1,07
-13	0,66	0,88	0,66	0,93	0,66	0,98	0,66	1,00	0,66	0,27	0,66	1,08
-11	0,70	0,88	0,70	0,93	0,70	0,98	0,70	1,00	0,69	0,27	0,69	1,08
-10	0,71	0,88	0,71	0,93	0,71	0,98	0,71	1,00	0,71	0,27	0,71	1,08
-9	0,74	0,89	0,74	0,94	0,74	0,99	0,74	1,01	0,73	0,28	0,73	1,09
-7	0,78	0,91	0,78	0,95	0,78	1,00	0,77	1,02	0,77	0,28	0,77	1,10
-6	0,80	0,92	0,80	0,96	0,80	1,01	0,79	1,03	0,79	0,28	0,78	1,10
-5	0,82	0,92	0,82	0,97	0,82	1,01	0,82	1,04	0,81	0,28	0,81	1,12
-3	0,86	0,94	0,86	0,98	0,86	1,03	0,85	1,06	0,85	0,29	0,84	1,11
-1	0,90	0,96	0,90	1,00	0,90	1,05	0,89	1,07	0,89	0,29	0,87	1,11
0	0,92	0,97	0,92	1,01	0,92	1,06	0,91	1,08	0,91	0,29	0,88	1,11
1	0,94	0,96	0,94	1,00	0,93	1,05	0,93	1,06	0,92	0,29	0,88	1,06
3	0,98	0,95	0,97	1,00	0,97	1,03	0,95	1,03	0,94	0,27	0,88	0,97
5	1,02	0,94	1,01	0,99	1,00	1,01	0,98	1,00	0,95	0,26	0,88	0,88
6	1,05	0,94	1,03	0,99	1,00	1,00	0,98	0,97	0,95	0,25	0,88	0,85
7	1,06	0,95	1,04	0,98	1,01	0,98	0,98	0,95	0,95	0,24	0,88	0,83
9	1,09	0,95	1,06	0,98	1,02	0,94	0,99	0,91	0,95	0,23	0,88	0,80
10	1,11	0,95	1,07	0,98	1,02	0,92	0,99	0,89	0,95	0,23	0,88	0,78
11	1,11	0,95	1,08	0,96	1,02	0,91	0,99	0,88	0,95	0,22	0,88	0,77
14	1,13	0,96	1,08	0,92	1,02	0,87	0,99	0,83	0,95	0,21	0,88	0,73
15	1,14	0,96	1,08	0,91	1,02	0,85	0,99	0,82	0,95	0,21	0,88	0,72

4

**RAS-52FSXN**

To\Ti	16		18		20		21		22		24	
	Q	P	Q	P	Q	P	Q	P	Q	P	Q	P
-20	0,52	0,85	0,52	0,90	0,52	0,94	0,52	0,97	0,52	0,99	0,52	1,04
-17	0,58	0,86	0,58	0,91	0,58	0,95	0,58	0,98	0,58	1,00	0,58	1,05
-15	0,62	0,87	0,62	0,91	0,62	0,96	0,62	0,98	0,62	1,01	0,61	1,06
-13	0,65	0,87	0,65	0,91	0,65	0,96	0,65	0,99	0,65	1,01	0,65	1,06
-11	0,69	0,87	0,69	0,92	0,69	0,96	0,69	0,99	0,69	1,01	0,69	1,07
-10	0,71	0,87	0,71	0,92	0,71	0,96	0,71	0,99	0,71	1,01	0,71	1,07
-9	0,73	0,88	0,73	0,92	0,73	0,97	0,73	1,00	0,73	1,02	0,72	1,07
-7	0,77	0,90	0,77	0,94	0,77	0,99	0,77	1,01	0,77	1,04	0,76	1,09
-6	0,79	0,91	0,79	0,95	0,79	1,00	0,79	1,02	0,79	1,05	0,78	1,09
-5	0,82	0,91	0,81	0,96	0,81	1,00	0,81	1,03	0,81	1,05	0,80	1,10
-3	0,86	0,93	0,85	0,97	0,85	1,02	0,85	1,05	0,85	1,07	0,83	1,11
-1	0,90	0,95	0,89	0,99	0,89	1,04	0,89	1,07	0,88	1,09	0,86	1,12
0	0,92	0,96	0,92	1,00	0,91	1,05	0,91	1,08	0,90	1,10	0,88	1,13
1	0,94	0,96	0,93	1,00	0,93	1,04	0,92	1,06	0,91	1,08	0,88	1,08
3	0,98	0,94	0,97	0,99	0,96	1,03	0,95	1,03	0,93	1,02	0,88	0,98
5	1,02	0,93	1,01	0,98	1,00	1,01	0,99	1,00	0,96	0,97	0,88	0,88
6	1,06	0,93	1,03	0,97	1,00	0,98	0,99	0,97	0,96	0,93	0,88	0,85
7	1,07	0,93	1,04	0,97	1,01	0,98	0,99	0,95	0,96	0,91	0,88	0,83
9	1,10	0,94	1,06	0,97	1,02	0,94	0,99	0,91	0,96	0,87	0,88	0,80
10	1,11	0,94	1,07	0,97	1,02	0,92	0,99	0,89	0,96	0,85	0,88	0,78
11	1,11	0,94	1,08	0,96	1,02	0,91	0,99	0,87	0,96	0,84	0,88	0,77
14	1,13	0,95	1,08	0,92	1,02	0,86	0,99	0,83	0,96	0,79	0,88	0,73
15	1,14	0,96	1,08	0,91	1,02	0,85	0,99	0,81	0,96	0,78	0,88	0,71

**RAS-54FSXN**

To\Ti	16		18		20		21		22		24	
	Q	P	Q	P	Q	P	Q	P	Q	P	Q	P
-20	0,53	0,86	0,53	0,91	0,53	0,95	0,53	0,98	0,52	1,00	0,52	1,05
-17	0,58	0,87	0,58	0,91	0,58	0,96	0,58	0,99	0,58	1,01	0,58	1,06
-15	0,62	0,87	0,62	0,92	0,62	0,97	0,62	0,99	0,62	1,02	0,62	1,07
-13	0,66	0,88	0,66	0,92	0,66	0,97	0,66	1,00	0,66	1,02	0,65	1,07
-11	0,69	0,88	0,69	0,93	0,69	0,97	0,69	1,00	0,69	1,02	0,69	1,07
-10	0,71	0,88	0,71	0,93	0,71	0,97	0,71	1,00	0,71	1,02	0,71	1,07
-9	0,73	0,89	0,73	0,93	0,73	0,98	0,73	1,01	0,73	1,03	0,73	1,08
-7	0,78	0,90	0,78	0,95	0,77	1,00	0,77	1,02	0,77	1,05	0,76	1,10
-6	0,80	0,91	0,80	0,96	0,80	1,01	0,79	1,03	0,79	1,06	0,78	1,10
-5	0,82	0,92	0,82	0,97	0,82	1,01	0,81	1,04	0,81	1,07	0,81	1,12
-3	0,86	0,94	0,86	0,99	0,86	1,03	0,85	1,06	0,85	1,09	0,84	1,13
-1	0,90	0,96	0,90	1,00	0,90	1,05	0,89	1,08	0,89	1,11	0,87	1,13
0	0,92	0,97	0,92	1,01	0,92	1,07	0,91	1,09	0,91	1,12	0,88	1,14
1	0,94	0,96	0,94	1,01	0,93	1,05	0,93	1,07	0,92	1,09	0,88	1,09
3	0,98	0,95	0,98	0,99	0,97	1,03	0,96	1,04	0,94	1,03	0,88	0,98
5	1,02	0,93	1,01	0,98	1,00	1,01	0,98	1,00	0,96	0,96	0,88	0,88
6	1,06	0,93	1,03	0,97	1,00	1,00	0,98	0,97	0,96	0,93	0,88	0,84
7	1,07	0,93	1,04	0,97	1,01	0,98	0,98	0,95	0,96	0,91	0,88	0,83
9	1,10	0,93	1,06	0,97	1,02	0,94	0,99	0,91	0,96	0,87	0,88	0,79
10	1,11	0,94	1,07	0,97	1,02	0,92	0,99	0,89	0,96	0,85	0,88	0,78
11	1,11	0,94	1,07	0,96	1,02	0,90	0,99	0,87	0,96	0,83	0,88	0,76
14	1,13	0,95	1,08	0,92	1,02	0,86	0,99	0,83	0,96	0,79	0,88	0,72
15	1,13	0,96	1,08	0,91	1,02	0,84	0,99	0,81	0,96	0,78	0,88	0,71

4

## 4.5 Outdoor unit capacity with total horsepower of combined indoor unit

The following tables show the examples of outdoor unit capacity which corresponds with total horsepower of combined indoor unit, according to the "Capacity Characteristic Curve" on previous pages.



### NOTE

- \* : This values are in kcal/h.

Total	Outdoor Unit Capacity Unit: kW (x1,000kcal/h)											
	RAS-8FSXN				RAS-10FSXN				RAS-12FSXN			
	Cooling		Heating		Cooling		Heating		Cooling		Heating	
4	11,2	*9,63	12,5	*10,75	—				—			
4,5	12,6	*10,84	14,06	*12,09	—				—			
5	14	*12,04	15,63	*13,44	14	*12,04	15,75	*13,55	—			
5,5	15,4	*13,24	17,19	*14,78	15,4	*13,24	17,33	*14,9	—			
6	16,8	*14,45	18,75	*16,13	16,8	*14,45	18,9	*16,25	16,75	*14,41	18,75	*16,13
6,5	18,2	*15,65	20,31	*17,47	18,2	*15,65	20,48	*17,61	18,15	*15,61	20,31	*17,47
7	19,6	*16,86	21,87	*18,81	19,6	*16,86	22,05	*18,96	19,54	*16,81	21,87	*18,81
7,5	21	*18,06	23,44	*20,16	21	*18,06	23,62	*20,32	20,94	*18,01	23,44	*20,16
8	22,4	*19,26	25	*21,5	22,4	*19,26	25,2	*21,67	22,34	*19,21	25	*21,5
8,5	22,4	*19,26	25	*21,5	23,8	*20,47	26,77	*23,03	23,73	*20,41	26,56	*22,84
9	22,4	*19,26	25	*21,5	25,2	*21,67	28,35	*24,38	25,13	*21,61	28,12	*24,19
9,5	22,4	*19,26	25	*21,5	26,6	*22,88	29,92	*25,74	26,52	*22,81	29,69	*25,53
10	22,4	*19,26	25	*21,5	28	*24,08	31,5	*27,09	27,92	*24,01	31,25	*26,87
10,5	—				28	*24,08	31,5	*27,09	29,32	*25,21	32,81	*28,22
11	—				28	*24,08	31,5	*27,09	30,71	*26,41	34,38	*29,56
11,5	—				28	*24,08	31,5	*27,09	32,11	*27,61	35,94	*30,91
12	—				28	*24,08	31,5	*27,09	33,5	*28,81	37,5	*32,25
12,5	—				28	*24,08	31,5	*27,09	33,5	*28,81	37,5	*32,25
13	—				28	*24,08	31,5	*27,09	33,5	*28,81	37,5	*32,25
13,5	—				—				33,5	*28,81	37,5	*32,25
14	—				—				33,5	*28,81	37,5	*32,25
14,5	—				—				33,5	*28,81	37,5	*32,25
15	—				—				33,5	*28,81	37,5	*32,25
15,5	—				—				33,5	*28,81	37,5	*32,25



Total	Outdoor Unit Capacity Unit: kW (x1,000kcal/h)											
	RAS-14FSXN				RAS-16FSXN				RAS-18FSXN			
	Cooling		Heating		Cooling		Heating		Cooling		Heating	
7	20	*17,2	22,5	*19,35	—				—			
7,5	21,43	*18,43	24,1	*20,73	—				—			
8	22,86	*19,66	25,71	*22,11	22,5	*19,35	25	*21,5	—			
8,5	24,28	*20,88	27,32	*23,49	23,91	*20,56	26,56	*22,84	—			
9	25,71	*22,11	28,93	*24,88	25,31	*21,77	28,12	*24,19	25	*21,5	28	*24,08
9,5	27,14	*23,34	30,53	*26,26	26,72	*22,98	29,69	*25,53	26,39	*22,7	29,55	*25,42
10	28,57	*24,57	32,14	*27,64	28,12	*24,19	31,25	*26,87	27,78	*23,89	31,11	*26,75
10,5	30	*25,8	33,75	*29,02	29,53	*25,4	32,81	*28,22	29,17	*25,09	32,67	*28,09
11	31,43	*27,03	35,35	*30,4	30,94	*26,61	34,38	*29,56	30,56	*26,28	34,22	*29,43
11,5	32,86	*28,26	36,96	*31,79	32,34	*27,82	35,94	*30,91	31,95	*27,47	35,78	*30,77
12	34,28	*29,48	38,57	*33,17	33,75	*29,03	37,5	*32,25	33,34	*28,67	37,33	*32,11
12,5	35,71	*30,71	40,18	*34,55	35,16	*30,23	39,06	*33,59	34,73	*29,86	38,89	*33,44
13	37,14	*31,94	41,78	*35,93	36,56	*31,44	40,63	*34,94	36,11	*31,06	40,44	*34,78
13,5	38,57	*33,17	43,39	*37,31	37,97	*32,65	42,19	*36,28	37,5	*32,25	42	*36,12
14	40	*34,4	45	*38,7	39,38	*33,86	43,75	*37,63	38,89	*33,45	43,55	*37,46
14,5	40	*34,4	45	*38,7	40,78	*35,07	45,31	*38,97	40,28	*34,64	45,11	*38,79
15	40	*34,4	45	*38,7	42,19	*36,28	46,88	*40,31	41,67	*35,84	46,67	*40,13
15,5	40	*34,4	45	*38,7	43,59	*37,49	48,44	*41,66	43,06	*37,03	48,22	*41,47
16	40	*34,4	45	*38,7	45	*38,7	50	*43	44,45	*38,23	49,78	*42,81
16,5	40	*34,4	45	*38,7	45	*38,7	50	*43	45,84	*39,42	51,33	*44,15
17	40	*34,4	45	*38,7	45	*38,7	50	*43	47,23	*40,61	52,89	*45,48
17,5	40	*34,4	45	*38,7	45	*38,7	50	*43	48,61	*41,81	54,44	*46,82
18	40	*34,4	45	*38,7	45	*38,7	50	*43	50	*43	56	*48,16
18,5	—				45	*38,7	50	*43	50	*43	56	*48,16
19	—				45	*38,7	50	*43	50	*43	56	*48,16
19,5	—				45	*38,7	50	*43	50	*43	56	*48,16
20	—				45	*38,7	50	*43	50	*43	56	*48,16
20,5	—				45	*38,7	50	*43	50	*43	56	*48,16
21	—				—				50	*43	56	*48,16
21,5	—				—				50	*43	56	*48,16
22	—				—				50	*43	56	*48,16
22,5	—				—				50	*43	56	*48,16
23	—				—				50	*43	56	*48,16

Total	Outdoor Unit Capacity Unit: kW (x1,000kcal/h)											
	RAS-20FSXN				RAS-22FSXN				RAS-24FSXN			
	Cooling		Heating		Cooling		Heating		Cooling		Heating	
10	28	*24,08	31,5	*27,09	—							
10,5	29,4	*25,28	33,08	*28,44	—							
11	30,8	*26,49	34,65	*29,8	30,75	*26,45	34,5	*29,67	—			
11,5	32,2	*27,69	36,23	*31,15	32,15	*27,65	36,07	*31,02	—			
12	33,6	*28,9	37,8	*32,51	33,55	*28,85	37,64	*32,37	34,5	*29,67	38,75	*33,32
12,5	35	*30,1	39,38	*33,86	34,94	*30,05	39,2	*33,72	35,94	*30,91	40,36	*34,71
13	36,4	*31,3	40,95	*35,22	36,34	*31,25	40,77	*35,06	37,38	*32,14	41,98	*36,1
13,5	37,8	*32,51	42,53	*36,57	37,74	*32,46	42,34	*36,41	38,81	*33,38	43,59	*37,49
14	39,2	*33,71	44,1	*37,93	39,14	*33,66	43,91	*37,76	40,25	*34,62	45,21	*38,88
14,5	40,6	*34,92	45,68	*39,28	40,53	*34,86	45,48	*39,11	41,69	*35,85	46,82	*40,27
15	42	*36,12	47,25	*40,64	41,93	*36,06	47,04	*40,46	43,13	*37,09	48,44	*41,65
15,5	43,4	*37,32	48,83	*41,99	43,33	*37,26	48,61	*41,81	44,56	*38,32	50,05	*43,04
16	44,8	*38,53	50,4	*43,34	44,73	*38,47	50,18	*43,16	46	*39,56	51,66	*44,43
16,5	46,2	*39,73	51,98	*44,7	46,13	*39,67	51,75	*44,5	47,44	*40,8	53,28	*45,82
17	47,6	*40,94	53,55	*46,05	47,52	*40,87	53,32	*45,85	48,87	*42,03	54,89	*47,21
17,5	49	*42,14	55,12	*47,41	48,92	*42,07	54,89	*47,2	50,31	*43,27	56,51	*48,6
18	50,4	*43,34	56,7	*48,76	50,32	*43,27	56,45	*48,55	51,75	*44,5	58,12	*49,98
18,5	51,8	*44,55	58,27	*50,12	51,72	*44,48	58,02	*49,9	53,19	*45,74	59,74	*51,37
19	53,2	*45,75	59,85	*51,47	53,11	*45,68	59,59	*51,25	54,62	*46,98	61,35	*52,76
19,5	54,6	*46,96	61,42	*52,83	54,51	*46,88	61,16	*52,6	56,06	*48,21	62,97	*54,15
20	56	*48,16	63	*54,18	55,91	*48,08	62,73	*53,94	57,5	*49,45	64,58	*55,54
20,5	56	*48,16	63	*54,18	57,31	*49,28	64,29	*55,29	58,94	*50,69	66,19	*56,93
21	56	*48,16	63	*54,18	58,71	*50,49	65,86	*56,64	60,37	*51,92	67,81	*58,32
21,5	56	*48,16	63	*54,18	60,1	*51,69	67,43	*57,99	61,81	*53,16	69,42	*59,7
22	56	*48,16	63	*54,18	61,5	*52,89	69	*59,34	63,25	*54,39	71,04	*61,09
22,5	56	*48,16	63	*54,18	61,5	*52,89	69	*59,34	64,69	*55,63	72,65	*62,48
23	56	*48,16	63	*54,18	61,5	*52,89	69	*59,34	66,12	*56,87	74,27	*63,87
23,5	56	*48,16	63	*54,18	61,5	*52,89	69	*59,34	67,56	*58,1	75,88	*65,26
24	56	*48,16	63	*54,18	61,5	*52,89	69	*59,34	69	*59,34	77,5	*66,65
24,5	56	*48,16	63	*54,18	61,5	*52,89	69	*59,34	69	*59,34	77,5	*66,65
25	56	*48,16	63	*54,18	61,5	*52,89	69	*59,34	69	*59,34	77,5	*66,65
25,5	56	*48,16	63	*54,18	61,5	*52,89	69	*59,34	69	*59,34	77,5	*66,65
26	56	*48,16	63	*54,18	61,5	*52,89	69	*59,34	69	*59,34	77,5	*66,65

Total	Outdoor Unit Capacity Unit: kW (x1,000kcal/h)									
	RAS-20FSXN		RAS-22FSXN				RAS-24FSXN			
	Cooling	Heating	Cooling		Heating		Cooling		Heating	
26,5	—		61,5	*52,89	69	*59,34	69	*59,34	77,5	*66,65
27			61,5	*52,89	69	*59,34	69	*59,34	77,5	*66,65
27,5			61,5	*52,89	69	*59,34	69	*59,34	77,5	*66,65
28			61,5	*52,89	69	*59,34	69	*59,34	77,5	*66,65
28,5			61,5	*52,89	69	*59,34	69	*59,34	77,5	*66,65
29			—				69	*59,34	77,5	*66,65
29,5			—				69	*59,34	77,5	*66,65
30			—				69	*59,34	77,5	*66,65
30,5			—				69	*59,34	77,5	*66,65
31			—				69	*59,34	77,5	*66,65

4

Total	Outdoor Unit Capacity Unit: kW (x1,000kcal/h)											
	RAS-26FSXN				RAS-28FSXN				RAS-30FSXN			
	Cooling		Heating		Cooling		Heating		Cooling		Heating	
13	36,5	*31,39	41,25	*35,47	—				—			
13,5	37,9	*32,6	42,84	*36,84	—				—			
14	39,31	*33,8	44,42	*38,2	40	*34,4	45	*38,7	—			
14,5	40,71	*35,01	46,01	*39,57	41,43	*35,63	46,61	*40,08	—			
15	42,12	*36,22	47,6	*40,93	42,86	*36,86	48,21	*41,46	42,5	*36,55	47,5	*40,85
15,5	43,52	*37,43	49,18	*42,3	44,28	*38,08	49,82	*42,85	43,92	*37,77	49,08	*42,21
16	44,92	*38,63	50,77	*43,66	45,71	*39,31	51,43	*44,23	45,33	*38,99	50,67	*43,57
16,5	46,33	*39,84	52,35	*45,02	47,14	*40,54	53,04	*45,61	46,75	*40,2	52,25	*44,94
17	47,73	*41,05	53,94	*46,39	48,57	*41,77	54,64	*46,99	48,17	*41,42	53,83	*46,3
17,5	49,13	*42,26	55,53	*47,75	50	*43	56,25	*48,38	49,58	*42,64	55,42	*47,66
18	50,54	*43,46	57,11	*49,12	51,43	*44,23	57,86	*49,76	51	*43,86	57	*49,02
18,5	51,94	*44,67	58,7	*50,48	52,85	*45,45	59,46	*51,14	52,42	*45,08	58,58	*50,38
19	53,35	*45,88	60,29	*51,85	54,28	*46,68	61,07	*52,52	53,83	*46,3	60,17	*51,74
19,5	54,75	*47,09	61,87	*53,21	55,71	*47,91	62,68	*53,9	55,25	*47,51	61,75	*53,11
20	56,15	*48,29	63,46	*54,58	57,14	*49,14	64,29	*55,29	56,67	*48,73	63,33	*54,47
20,5	57,56	*49,5	65,05	*55,94	58,57	*50,37	65,89	*56,67	58,08	*49,95	64,92	*55,83
21	58,96	*50,71	66,63	*57,3	60	*51,6	67,5	*58,05	59,5	*51,17	66,5	*57,19
21,5	60,37	*51,91	68,22	*58,67	61,43	*52,83	69,11	*59,43	60,92	*52,39	68,08	*58,55
22	61,77	*53,12	69,81	*60,03	62,85	*54,05	70,71	*60,81	62,33	*53,61	69,67	*59,91
22,5	63,17	*54,33	71,39	*61,4	64,28	*55,28	72,32	*62,2	63,75	*54,82	71,25	*61,28
23	64,58	*55,54	72,98	*62,76	65,71	*56,51	73,93	*63,58	65,17	*56,04	72,83	*62,64
23,5	65,98	*56,74	74,57	*64,13	67,14	*57,74	75,54	*64,96	66,58	*57,26	74,42	*64
24	67,38	*57,95	76,15	*65,49	68,57	*58,97	77,14	*66,34	68	*58,48	76	*65,36
24,5	68,79	*59,16	77,74	*66,86	70	*60,2	78,75	*67,73	69,42	*59,7	77,58	*66,72
25	70,19	*60,37	79,32	*68,22	71,42	*61,43	80,36	*69,11	70,83	*60,92	79,17	*68,08
25,5	71,6	*61,57	80,91	*69,58	72,85	*62,65	81,96	*70,49	72,25	*62,13	80,75	*69,45
26	73	*62,78	82,5	*70,95	74,28	*63,88	83,57	*71,87	73,67	*63,35	82,33	*70,81
26,5	73	*62,78	82,5	*70,95	75,71	*65,11	85,18	*73,25	75,08	*64,57	83,92	*72,17
27	73	*62,78	82,5	*70,95	77,14	*66,34	86,79	*74,64	76,5	*65,79	85,5	*73,53
27,5	73	*62,78	82,5	*70,95	78,57	*67,57	88,39	*76,02	77,92	*67,01	87,08	*74,89
28	73	*62,78	82,5	*70,95	80	*68,8	90	*77,4	79,33	*68,23	88,67	*76,25
28,5	73	*62,78	82,5	*70,95	80	*68,8	90	*77,4	80,75	*69,44	90,25	*77,62
29	73	*62,78	82,5	*70,95	80	*68,8	90	*77,4	82,17	*70,66	91,83	*78,98
29,5	73	*62,78	82,5	*70,95	80	*68,8	90	*77,4	83,58	*71,88	93,42	*80,34
30	73	*62,78	82,5	*70,95	80	*68,8	90	*77,4	85	*73,1	95	*81,7
30,5	73	*62,78	82,5	*70,95	80	*68,8	90	*77,4	85	*73,1	95	*81,7
31	73	*62,78	82,5	*70,95	80	*68,8	90	*77,4	85	*73,1	95	*81,7
31,5	73	*62,78	82,5	*70,95	80	*68,8	90	*77,4	85	*73,1	95	*81,7

Total	Outdoor Unit Capacity Unit: kW (x1,000kcal/h)																			
	RAS-26FSXN				RAS-28FSXN				RAS-30FSXN											
	Cooling		Heating		Cooling		Heating		Cooling		Heating									
32	73	*62,78	82,5	*70,95	80	*68,8	90	*77,4	85	*73,1	95	*81,7								
32,5	73	*62,78	82,5	*70,95	80	*68,8	90	*77,4	85	*73,1	95	*81,7								
33	73	*62,78	82,5	*70,95	80	*68,8	90	*77,4	85	*73,1	95	*81,7								
33,5	73	*62,78	82,5	*70,95	80	*68,8	90	*77,4	85	*73,1	95	*81,7								
34					80	*68,8	90	*77,4	85	*73,1	95	*81,7								
34,5					80	*68,8	90	*77,4	85	*73,1	95	*81,7								
35					80	*68,8	90	*77,4	85	*73,1	95	*81,7								
35,5					80	*68,8	90	*77,4	85	*73,1	95	*81,7								
36					80	*68,8	90	*77,4	85	*73,1	95	*81,7								
36,5													85	*73,1	95	*81,7				
37													85	*73,1	95	*81,7				
37,5																	85	*73,1	95	*81,7
38																	85	*73,1	95	*81,7
38,5																	85	*73,1	95	*81,7
39																	85	*73,1	95	*81,7

4

Total	Outdoor Unit Capacity Unit: kW (x1,000kcal/h)											
	RAS-32FSXN				RAS-34FSXN				RAS-36FSXN			
	Cooling		Heating		Cooling		Heating		Cooling		Heating	
16	45	*38,7	50	*43	—				—			
16,5	46,41	*39,91	51,56	*44,34	—				—			
17	47,81	*41,12	53,12	*45,69	47,5	*40,85	53	*45,58	—			
17,5	49,22	*42,33	54,69	*47,03	48,89	*42,05	54,56	*46,92	—			
18	50,62	*43,54	56,25	*48,37	50,29	*43,25	56,12	*48,26	50	*43	56	*48,16
18,5	52,03	*44,75	57,81	*49,72	51,69	*44,45	57,68	*49,6	51,39	*44,19	57,55	*49,5
19	53,44	*45,96	59,37	*51,06	53,09	*45,65	59,23	*50,94	52,78	*45,39	59,11	*50,83
19,5	54,84	*47,17	60,94	*52,41	54,48	*46,86	60,79	*52,28	54,17	*46,58	60,66	*52,17
20	56,25	*48,37	62,5	*53,75	55,88	*48,06	62,35	*53,62	55,56	*47,78	62,22	*53,51
20,5	57,66	*49,58	64,06	*55,09	57,28	*49,26	63,91	*54,96	56,94	*48,97	63,78	*54,85
21	59,06	*50,79	65,62	*56,44	58,67	*50,46	65,47	*56,3	58,33	*50,17	65,33	*56,18
21,5	60,47	*52	67,19	*57,78	60,07	*51,66	67,03	*57,64	59,72	*51,36	66,89	*57,52
22	61,87	*53,21	68,75	*59,12	61,47	*52,86	68,59	*58,98	61,11	*52,56	68,44	*58,86
22,5	63,28	*54,42	70,31	*60,47	62,86	*54,06	70,15	*60,33	62,5	*53,75	70	*60,2
23	64,69	*55,63	71,87	*61,81	64,26	*55,27	71,7	*61,67	63,89	*54,94	71,55	*61,54
23,5	66,09	*56,84	73,44	*63,16	65,66	*56,47	73,26	*63,01	65,28	*56,14	73,11	*62,87
24	67,5	*58,05	75	*64,5	67,06	*57,67	74,82	*64,35	66,67	*57,33	74,66	*64,21
24,5	68,91	*59,26	76,56	*65,84	68,45	*58,87	76,38	*65,69	68,06	*58,53	76,22	*65,55
25	70,31	*60,47	78,12	*67,19	69,85	*60,07	77,94	*67,03	69,44	*59,72	77,77	*66,89
25,5	71,72	*61,68	79,69	*68,53	71,25	*61,27	79,5	*68,37	70,83	*60,92	79,33	*68,22
26	73,12	*62,89	81,25	*69,87	72,64	*62,47	81,06	*69,71	72,22	*62,11	80,89	*69,56
26,5	74,53	*64,1	82,81	*71,22	74,04	*63,68	82,62	*71,05	73,61	*63,31	82,44	*70,9
27	75,94	*65,31	84,37	*72,56	75,44	*64,88	84,18	*72,39	75	*64,5	84	*72,24
27,5	77,34	*66,52	85,94	*73,91	76,83	*66,08	85,73	*73,73	76,39	*65,69	85,55	*73,58
28	78,75	*67,72	87,5	*75,25	78,23	*67,28	87,29	*75,07	77,78	*66,89	87,11	*74,91
28,5	80,16	*68,93	89,06	*76,59	79,63	*68,48	88,85	*76,41	79,17	*68,08	88,66	*76,25
29	81,56	*70,14	90,62	*77,94	81,03	*69,68	90,41	*77,75	80,56	*69,28	90,22	*77,59
29,5	82,97	*71,35	92,19	*79,28	82,42	*70,88	91,97	*79,09	81,95	*70,47	91,77	*78,93
30	84,37	*72,56	93,75	*80,62	83,82	*72,09	93,53	*80,43	83,33	*71,67	93,33	*80,26
30,5	85,78	*73,77	95,31	*81,97	85,22	*73,29	95,09	*81,77	84,72	*72,86	94,89	*81,6
31	87,19	*74,98	96,87	*83,31	86,61	*74,49	96,65	*83,12	86,11	*74,06	96,44	*82,94
31,5	88,59	*76,19	98,44	*84,66	88,01	*75,69	98,2	*84,46	87,5	*75,25	98	*84,28
32	90	*77,4	100	*86	89,41	*76,89	99,76	*85,8	88,89	*76,45	99,55	*85,61
32,5	90	*77,4	100	*86	90,8	*78,09	101,32	*87,14	90,28	*77,64	101,11	*86,95
33	90	*77,4	100	*86	92,2	*79,29	102,88	*88,48	91,67	*78,83	102,66	*88,29
33,5	90	*77,4	100	*86	93,6	*80,5	104,44	*89,82	93,06	*80,03	104,22	*89,63
34	90	*77,4	100	*86	95	*81,7	106	*91,16	94,45	*81,22	105,77	*90,97
34,5	90	*77,4	100	*86	95	*81,7	106	*91,16	95,83	*82,42	107,33	*92,3

Total	Outdoor Unit Capacity Unit: kW (x1,000kcal/h)															
	RAS-32FSXN				RAS-34FSXN				RAS-36FSXN							
	Cooling		Heating		Cooling		Heating		Cooling		Heating					
35	90	*77,4	100	*86	95	*81,7	106	*91,16	97,22	*83,61	108,89	*93,64				
35,5	90	*77,4	100	*86	95	*81,7	106	*91,16	98,61	*84,81	110,44	*94,98				
36	90	*77,4	100	*86	95	*81,7	106	*91,16	100	*86	112	*96,32				
36,5	90	*77,4	100	*86	95	*81,7	106	*91,16	100	*86	112	*96,32				
37	90	*77,4	100	*86	95	*81,7	106	*91,16	100	*86	112	*96,32				
37,5	90	*77,4	100	*86	95	*81,7	106	*91,16	100	*86	112	*96,32				
38	90	*77,4	100	*86	95	*81,7	106	*91,16	100	*86	112	*96,32				
38,5	90	*77,4	100	*86	95	*81,7	106	*91,16	100	*86	112	*96,32				
39	90	*77,4	100	*86	95	*81,7	106	*91,16	100	*86	112	*96,32				
39,5	90	*77,4	100	*86	95	*81,7	106	*91,16	100	*86	112	*96,32				
40,5	90	*77,4	100	*86	95	*81,7	106	*91,16	100	*86	112	*96,32				
41	90	*77,4	100	*86	95	*81,7	106	*91,16	100	*86	112	*96,32				
41,5	90	*77,4	100	*86	95	*81,7	106	*91,16	100	*86	112	*96,32				
42	—				95	*81,7	106	*91,16	100	*86	112	*96,32				
42,5					95	*81,7	106	*91,16	100	*86	112	*96,32				
43					95	*81,7	106	*91,16	100	*86	112	*96,32				
43,5					95	*81,7	106	*91,16	100	*86	112	*96,32				
44					95	*81,7	106	*91,16	100	*86	112	*96,32				
44,1					95	*81,7	106	*91,16	100	*86	112	*96,32				
44,2					95	*81,7	106	*91,16	100	*86	112	*96,32				
44,3					—				—				100	*86	112	*96,32
44,4													100	*86	112	*96,32
44,5													100	*86	112	*96,32
44,6													100	*86	112	*96,32
44,7													100	*86	112	*96,32
44,8													100	*86	112	*96,32
44,9													100	*86	112	*96,32
45													100	*86	112	*96,32
45,5													100	*86	112	*96,32
46	100	*86	112	*96,32												
46,5	100	*86	112	*96,32												

Total	Outdoor Unit Capacity Unit: kW (x1,000kcal/h)											
	RAS-38FSXN				RAS-40FSXN				RAS-42FSXN			
	Cooling		Heating		Cooling		Heating		Cooling		Heating	
19	54,5	*46,87	59	*50,74	—				—			
19,5	55,93	*48,1	60,55	*52,08	—				—			
20	57,37	*49,34	62,11	*53,41	56	*48,16	62,5	*53,75	—			
20,5	58,8	*50,57	63,66	*54,75	57,4	*49,36	64,06	*55,09	—			
21	60,24	*51,8	65,21	*56,08	58,8	*50,57	65,62	*56,44	59	*50,74	66	*56,76
21,5	61,67	*53,04	66,76	*57,42	60,2	*51,77	67,19	*57,78	60,4	*51,95	67,57	*58,11
22	63,1	*54,27	68,32	*58,75	61,6	*52,98	68,75	*59,12	61,81	*53,16	69,14	*59,46
22,5	64,54	*55,5	69,87	*60,09	63	*54,18	70,31	*60,47	63,21	*54,36	70,72	*60,82
23	65,97	*56,74	71,42	*61,42	64,4	*55,38	71,87	*61,81	64,62	*55,57	72,29	*62,17
23,5	67,41	*57,97	72,97	*62,76	65,8	*56,59	73,44	*63,16	66,02	*56,78	73,86	*63,52
24	68,84	*59,2	74,53	*64,09	67,2	*57,79	75	*64,5	67,43	*57,99	75,43	*64,87
24,5	70,28	*60,44	76,08	*65,43	68,6	*59	76,56	*65,84	68,83	*59,2	77	*66,22
25	71,71	*61,67	77,63	*66,76	70	*60,2	78,12	*67,19	70,24	*60,4	78,57	*67,57
25,5	73,14	*62,9	79,19	*68,1	71,4	*61,4	79,69	*68,53	71,64	*61,61	80,14	*68,92
26	74,58	*64,14	80,74	*69,43	72,8	*62,61	81,25	*69,87	73,05	*62,82	81,72	*70,28
26,5	76,01	*65,37	82,29	*70,77	74,2	*63,81	82,81	*71,22	74,45	*64,03	83,29	*71,63
27	77,45	*66,6	83,84	*72,11	75,6	*65,02	84,37	*72,56	75,86	*65,24	84,86	*72,98
27,5	78,88	*67,84	85,4	*73,44	77	*66,22	85,94	*73,91	77,26	*66,44	86,43	*74,33
28	80,32	*69,07	86,95	*74,78	78,4	*67,42	87,5	*75,25	78,67	*67,65	88	*75,68
28,5	81,75	*70,3	88,5	*76,11	79,8	*68,63	89,06	*76,59	80,07	*68,86	89,57	*77,03
29	83,18	*71,54	90,05	*77,45	81,2	*69,83	90,62	*77,94	81,48	*70,07	91,14	*78,38
29,5	84,62	*72,77	91,61	*78,78	82,6	*71,04	92,19	*79,28	82,88	*71,28	92,72	*79,74
30	86,05	*74	93,16	*80,12	84	*72,24	93,75	*80,62	84,28	*72,49	94,29	*81,09
30,5	87,49	*75,24	94,71	*81,45	85,4	*73,44	95,31	*81,97	85,69	*73,69	95,86	*82,44
31	88,92	*76,47	96,26	*82,79	86,8	*74,65	96,87	*83,31	87,09	*74,9	97,43	*83,79
31,5	90,35	*77,7	97,82	*84,12	88,2	*75,85	98,44	*84,66	88,5	*76,11	99	*85,14
32	91,79	*78,94	99,37	*85,46	89,6	*77,06	100	*86	89,9	*77,32	100,57	*86,49
32,5	93,22	*80,17	100,92	*86,79	91	*78,26	101,56	*87,34	91,31	*78,53	102,14	*87,84
33	94,66	*81,41	102,47	*88,13	92,4	*79,46	103,13	*88,69	92,71	*79,73	103,72	*89,2
33,5	96,09	*82,64	104,03	*89,46	93,8	*80,67	104,69	*90,03	94,12	*80,94	105,29	*90,55
34	97,53	*83,87	105,58	*90,8	95,2	*81,87	106,25	*91,37	95,52	*82,15	106,86	*91,9
34,5	98,96	*85,11	107,13	*92,13	96,6	*83,08	107,81	*92,72	96,93	*83,36	108,43	*93,25
35	100,39	*86,34	108,69	*93,47	98	*84,28	109,38	*94,06	98,33	*84,57	110	*94,6
35,5	101,83	*87,57	110,24	*94,8	99,4	*85,48	110,94	*95,41	99,74	*85,77	111,57	*95,95
36	103,26	*88,81	111,79	*96,14	100,8	*86,69	112,5	*96,75	101,14	*86,98	113,14	*97,3
36,5	104,7	*90,04	113,34	*97,48	102,2	*87,89	114,06	*98,09	102,55	*88,19	114,72	*98,66
37	106,13	*91,27	114,9	*98,81	103,6	*89,1	115,63	*99,44	103,95	*89,4	116,29	*100,01
37,5	107,57	*92,51	116,45	*100,15	105	*90,3	117,19	*100,78	105,36	*90,61	117,86	*101,36
38	109	*93,74	118	*101,48	106,4	*91,5	118,75	*102,13	106,76	*91,81	119,43	*102,71
38,5	109	*93,74	118	*101,48	107,8	*92,71	120,31	*103,47	108,17	*93,02	121	*104,06
39	109	*93,74	118	*101,48	109,2	*93,91	121,88	*104,81	109,57	*94,23	122,57	*105,41
39,5	109	*93,74	118	*101,48	110,6	*95,12	123,44	*106,16	110,98	*95,44	124,14	*106,76
40	109	*93,74	118	*101,48	112	*96,32	125	*107,5	112,38	*96,65	125,72	*108,12
40,5	109	*93,74	118	*101,48	112	*96,32	125	*107,5	113,78	*97,85	127,29	*109,47



Total	Outdoor Unit Capacity Unit: kW (x1,000kcal/h)															
	RAS-38FSXN				RAS-40FSXN				RAS-42FSXN							
	Cooling		Heating		Cooling		Heating		Cooling		Heating					
41	109	*93,74	118	*101,48	112	*96,32	125	*107,5	115,19	*99,06	128,86	*110,82				
41,5	109	*93,74	118	*101,48	112	*96,32	125	*107,5	116,59	*100,27	130,43	*112,17				
42	109	*93,74	118	*101,48	112	*96,32	125	*107,5	118	*101,48	132	*113,52				
42,5	109	*93,74	118	*101,48	112	*96,32	125	*107,5	118	*101,48	132	*113,52				
43	109	*93,74	118	*101,48	112	*96,32	125	*107,5	118	*101,48	132	*113,52				
43,5	109	*93,74	118	*101,48	112	*96,32	125	*107,5	118	*101,48	132	*113,52				
44	109	*93,74	118	*101,48	112	*96,32	125	*107,5	118	*101,48	132	*113,52				
44,5	109	*93,74	118	*101,48	112	*96,32	125	*107,5	118	*101,48	132	*113,52				
45	109	*93,74	118	*101,48	112	*96,32	125	*107,5	118	*101,48	132	*113,52				
45,5	109	*93,74	118	*101,48	112	*96,32	125	*107,5	118	*101,48	132	*113,52				
46	109	*93,74	118	*101,48	112	*96,32	125	*107,5	118	*101,48	132	*113,52				
46,5	109	*93,74	118	*101,48	112	*96,32	125	*107,5	118	*101,48	132	*113,52				
47	109	*93,74	118	*101,48	112	*96,32	125	*107,5	118	*101,48	132	*113,52				
47,5	109	*93,74	118	*101,48	112	*96,32	125	*107,5	118	*101,48	132	*113,52				
48	109	*93,74	118	*101,48	112	*96,32	125	*107,5	118	*101,48	132	*113,52				
48,5	109	*93,74	118	*101,48	112	*96,32	125	*107,5	118	*101,48	132	*113,52				
49	109	*93,74	118	*101,48	112	*96,32	125	*107,5	118	*101,48	132	*113,52				
49,5	—				112	*96,32	125	*107,5	118	*101,48	132	*113,52				
50					112	*96,32	125	*107,5	118	*101,48	132	*113,52				
50,5					112	*96,32	125	*107,5	118	*101,48	132	*113,52				
51					112	*96,32	125	*107,5	118	*101,48	132	*113,52				
51,5					112	*96,32	125	*107,5	118	*101,48	132	*113,52				
52					112	*96,32	125	*107,5	118	*101,48	132	*113,52				
52,5					—				—				118	*101,48	132	*113,52
53													118	*101,48	132	*113,52
53,5													118	*101,48	132	*113,52
54													118	*101,48	132	*113,52
54,5	118	*101,48	132	*113,52												

Total	Outdoor Unit Capacity Unit: kW (x1,000kcal/h)											
	RAS-44FSXN				RAS-46FSXN				RAS-48FSXN			
	Cooling		Heating		Cooling		Heating		Cooling		Heating	
22	62,5	*53,75	70	*60,2	—							
22,5	63,92	*54,97	71,59	*61,57	—							
23	65,34	*56,19	73,18	*62,94	66	*56,76	72,5	*62,35	—			
23,5	66,76	*57,42	74,77	*64,3	67,44	*57,99	74,08	*63,71	—			
24	68,18	*58,64	76,36	*65,67	68,87	*59,23	75,65	*65,06	68	*58,48	75	*64,5
24,5	69,6	*59,86	77,95	*67,04	70,31	*60,46	77,23	*66,42	69,42	*59,7	76,56	*65,84
25	71,02	*61,08	79,54	*68,41	71,74	*61,7	78,8	*67,77	70,83	*60,92	78,12	*67,19
25,5	72,45	*62,3	81,14	*69,78	73,17	*62,93	80,38	*69,13	72,25	*62,13	79,69	*68,53
26	73,87	*63,52	82,73	*71,15	74,61	*64,16	81,96	*70,48	73,67	*63,35	81,25	*69,87
26,5	75,29	*64,75	84,32	*72,51	76,04	*65,4	83,53	*71,84	75,08	*64,57	82,81	*71,22
27	76,71	*65,97	85,91	*73,88	77,48	*66,63	85,11	*73,19	76,5	*65,79	84,37	*72,56
27,5	78,13	*67,19	87,5	*75,25	78,91	*67,87	86,69	*74,55	77,92	*67,01	85,94	*73,91
28	79,55	*68,41	89,09	*76,62	80,35	*69,1	88,26	*75,9	79,33	*68,23	87,5	*75,25
28,5	80,97	*69,63	90,68	*77,99	81,78	*70,33	89,84	*77,26	80,75	*69,44	89,06	*76,59
29	82,39	*70,85	92,27	*79,35	83,22	*71,57	91,41	*78,62	82,17	*70,66	90,62	*77,94
29,5	83,81	*72,08	93,86	*80,72	84,65	*72,8	92,99	*79,97	83,58	*71,88	92,19	*79,28
30	85,23	*73,3	95,45	*82,09	86,09	*74,04	94,57	*81,33	85	*73,1	93,75	*80,62
30,5	86,65	*74,52	97,04	*83,46	87,52	*75,27	96,14	*82,68	86,42	*74,32	95,31	*81,97
31	88,07	*75,74	98,64	*84,83	88,96	*76,5	97,72	*84,04	87,83	*75,54	96,87	*83,31
31,5	89,49	*76,96	100,23	*86,19	90,39	*77,74	99,29	*85,39	89,25	*76,75	98,44	*84,66
32	90,91	*78,18	101,82	*87,56	91,83	*78,97	100,87	*86,75	90,67	*77,97	100	*86
32,5	92,33	*79,41	103,41	*88,93	93,26	*80,21	102,45	*88,1	92,08	*79,19	101,56	*87,34
33	93,75	*80,63	105	*90,3	94,7	*81,44	104,02	*89,46	93,5	*80,41	103,13	*88,69
33,5	95,17	*81,85	106,59	*91,67	96,13	*82,67	105,6	*90,81	94,92	*81,63	104,69	*90,03
34	96,59	*83,07	108,18	*93,04	97,57	*83,91	107,17	*92,17	96,33	*82,85	106,25	*91,37
34,5	98,01	*84,29	109,77	*94,4	99	*85,14	108,75	*93,53	97,75	*84,06	107,81	*92,72
35	99,43	*85,51	111,36	*95,77	100,44	*86,37	110,33	*94,88	99,17	*85,28	109,38	*94,06
35,5	100,86	*86,74	112,95	*97,14	101,87	*87,61	111,9	*96,24	100,58	*86,5	110,94	*95,41
36	102,28	*87,96	114,54	*98,51	103,31	*88,84	113,48	*97,59	102	*87,72	112,5	*96,75
36,5	103,7	*89,18	116,14	*99,88	104,74	*90,08	115,06	*98,95	103,42	*88,94	114,06	*98,09
37	105,12	*90,4	117,73	*101,24	106,18	*91,31	116,63	*100,3	104,83	*90,16	115,63	*99,44
37,5	106,54	*91,62	119,32	*102,61	107,61	*92,54	118,21	*101,66	106,25	*91,37	117,19	*100,78
38	107,96	*92,84	120,91	*103,98	109,04	*93,78	119,78	*103,01	107,67	*92,59	118,75	*102,13
38,5	109,38	*94,07	122,5	*105,35	110,48	*95,01	121,36	*104,37	109,08	*93,81	120,31	*103,47
39	110,8	*95,29	124,09	*106,72	111,91	*96,25	122,94	*105,72	110,5	*95,03	121,88	*104,81
39,5	112,22	*96,51	125,68	*108,09	113,35	*97,48	124,51	*107,08	111,92	*96,25	123,44	*106,16
34	96,59	*83,07	108,18	*93,04	97,57	*83,91	107,17	*92,17	96,33	*82,85	106,25	*91,37
34,5	98,01	*84,29	109,77	*94,4	99	*85,14	108,75	*93,53	97,75	*84,06	107,81	*92,72
35	99,43	*85,51	111,36	*95,77	100,44	*86,37	110,33	*94,88	99,17	*85,28	109,38	*94,06
35,5	100,86	*86,74	112,95	*97,14	101,87	*87,61	111,9	*96,24	100,58	*86,5	110,94	*95,41
36	102,28	*87,96	114,54	*98,51	103,31	*88,84	113,48	*97,59	102	*87,72	112,5	*96,75
36,5	103,7	*89,18	116,14	*99,88	104,74	*90,08	115,06	*98,95	103,42	*88,94	114,06	*98,09
37	105,12	*90,4	117,73	*101,24	106,18	*91,31	116,63	*100,3	104,83	*90,16	115,63	*99,44
37,5	106,54	*91,62	119,32	*102,61	107,61	*92,54	118,21	*101,66	106,25	*91,37	117,19	*100,78

Total	Outdoor Unit Capacity Unit: kW (x1,000kcal/h)											
	RAS-44FSXN				RAS-46FSXN				RAS-48FSXN			
	Cooling		Heating		Cooling		Heating		Cooling		Heating	
38	107,96	*92,84	120,91	*103,98	109,04	*93,78	119,78	*103,01	107,67	*92,59	118,75	*102,13
38,5	109,38	*94,07	122,5	*105,35	110,48	*95,01	121,36	*104,37	109,08	*93,81	120,31	*103,47
39	110,8	*95,29	124,09	*106,72	111,91	*96,25	122,94	*105,72	110,5	*95,03	121,88	*104,81
39,5	112,22	*96,51	125,68	*108,09	113,35	*97,48	124,51	*107,08	111,92	*96,25	123,44	*106,16
40	113,64	*97,73	127,27	*109,45	114,78	*98,71	126,09	*108,44	113,33	*97,47	125	*107,5
40,5	115,06	*98,95	128,86	*110,82	116,22	*99,95	127,66	*109,79	114,75	*98,68	126,56	*108,84
41	116,48	*100,17	130,45	*112,19	117,65	*101,18	129,24	*111,15	116,17	*99,9	128,13	*110,19
41,5	117,9	*101,4	132,04	*113,56	119,09	*102,42	130,82	*112,5	117,58	*101,12	129,69	*111,53
42	119,32	*102,62	133,64	*114,93	120,52	*103,65	132,39	*113,86	119	*102,34	131,25	*112,88
42,5	120,74	*103,84	135,23	*116,29	121,96	*104,88	133,97	*115,21	120,42	*103,56	132,81	*114,22
43	122,16	*105,06	136,82	*117,66	123,39	*106,12	135,54	*116,57	121,83	*104,78	134,38	*115,56
43,5	123,58	*106,28	138,41	*119,03	124,83	*107,35	137,12	*117,92	123,25	*105,99	135,94	*116,91
44	125	*107,5	140	*120,4	126,26	*108,59	138,7	*119,28	124,67	*107,21	137,5	*118,25
44,5	125	*107,5	140	*120,4	127,7	*109,82	140,27	*120,63	126,08	*108,43	139,06	*119,59
45	125	*107,5	140	*120,4	129,13	*111,05	141,85	*121,99	127,5	*109,65	140,63	*120,94
45,5	125	*107,5	140	*120,4	130,57	*112,29	143,43	*123,35	128,92	*110,87	142,19	*122,28
46	125	*107,5	140	*120,4	132	*113,52	145	*124,7	130,33	*112,09	143,75	*123,63
46,5	125	*107,5	140	*120,4	132	*113,52	145	*124,7	131,75	*113,3	145,31	*124,97
47	125	*107,5	140	*120,4	132	*113,52	145	*124,7	133,17	*114,52	146,88	*126,31
47,5	125	*107,5	140	*120,4	132	*113,52	145	*124,7	134,58	*115,74	148,44	*127,66
48	125	*107,5	140	*120,4	132	*113,52	145	*124,7	136	*116,96	150	*129
48,5	125	*107,5	140	*120,4	132	*113,52	145	*124,7	136	*116,96	150	*129
49	125	*107,5	140	*120,4	132	*113,52	145	*124,7	136	*116,96	150	*129
49,5	125	*107,5	140	*120,4	132	*113,52	145	*124,7	136	*116,96	150	*129
50	125	*107,5	140	*120,4	132	*113,52	145	*124,7	136	*116,96	150	*129
50,5	125	*107,5	140	*120,4	132	*113,52	145	*124,7	136	*116,96	150	*129
51	125	*107,5	140	*120,4	132	*113,52	145	*124,7	136	*116,96	150	*129
51,5	125	*107,5	140	*120,4	132	*113,52	145	*124,7	136	*116,96	150	*129
52	125	*107,5	140	*120,4	132	*113,52	145	*124,7	136	*116,96	150	*129
52,5	125	*107,5	140	*120,4	132	*113,52	145	*124,7	136	*116,96	150	*129
53	125	*107,5	140	*120,4	132	*113,52	145	*124,7	136	*116,96	150	*129
53,5	125	*107,5	140	*120,4	132	*113,52	145	*124,7	136	*116,96	150	*129
54	125	*107,5	140	*120,4	132	*113,52	145	*124,7	136	*116,96	150	*129
54,5	125	*107,5	140	*120,4	132	*113,52	145	*124,7	136	*116,96	150	*129
55	125	*107,5	140	*120,4	132	*113,52	145	*124,7	136	*116,96	150	*129
55,5	125	*107,5	140	*120,4	132	*113,52	145	*124,7	136	*116,96	150	*129
56	125	*107,5	140	*120,4	132	*113,52	145	*124,7	136	*116,96	150	*129
56,5	125	*107,5	140	*120,4	132	*113,52	145	*124,7	136	*116,96	150	*129
57	125	*107,5	140	*120,4	132	*113,52	145	*124,7	136	*116,96	150	*129

Total	Outdoor Unit Capacity Unit: kW (x1,000kcal/h)									
	RAS-44FSXN		RAS-46FSXN				RAS-48FSXN			
	Cooling	Heating	Cooling		Heating		Cooling		Heating	
57,5	—	—	132	*113,52	145	*124,7	136	*116,96	150	*129
58			132	*113,52	145	*124,7	136	*116,96	150	*129
58,5			132	*113,52	145	*124,7	136	*116,96	150	*129
59			132	*113,52	145	*124,7	136	*116,96	150	*129
59,5			132	*113,52	145	*124,7	136	*116,96	150	*129
60			—				136	*116,96	150	*129
60,5			—				136	*116,96	150	*129
61			—				136	*116,96	150	*129
61,5			—				136	*116,96	150	*129
62			—				136	*116,96	150	*129

Total	Outdoor Unit Capacity Unit: kW (x1,000kcal/h)											
	RAS-50FSXN				RAS-52FSXN				RAS-54FSXN			
	Cooling		Heating		Cooling		Heating		Cooling		Heating	
25	70	*60,2	77,5	*66,65	—				—			
25,5	71,4	*61,4	79,05	*67,98	—				—			
26	72,8	*62,61	80,6	*69,32	72,5	*62,35	80	*68,8	—			
26,5	74,2	*63,81	82,15	*70,65	73,9	*63,55	81,54	*70,12	—			
27	75,6	*65,02	83,7	*71,98	75,29	*64,75	83,08	*71,45	75	*64,5	82,5	*70,95
27,5	77	*66,22	85,25	*73,31	76,68	*65,95	84,61	*72,77	76,39	*65,69	84,03	*72,26
28	78,4	*67,42	86,8	*74,65	78,08	*67,15	86,15	*74,09	77,78	*66,89	85,56	*73,58
28,5	79,8	*68,63	88,35	*75,98	79,47	*68,35	87,69	*75,41	79,17	*68,08	87,08	*74,89
29	81,2	*69,83	89,9	*77,31	80,87	*69,55	89,23	*76,74	80,56	*69,28	88,61	*76,21
29,5	82,6	*71,04	91,45	*78,65	82,26	*70,74	90,77	*78,06	81,95	*70,47	90,14	*77,52
30	84	*72,24	93	*79,98	83,65	*71,94	92,31	*79,38	83,33	*71,67	91,67	*78,83
30,5	85,4	*73,44	94,55	*81,31	85,05	*73,14	93,85	*80,71	84,72	*72,86	93,19	*80,15
31	86,8	*74,65	96,1	*82,65	86,44	*74,34	95,38	*82,03	86,11	*74,06	94,72	*81,46
31,5	88,2	*75,85	97,65	*83,98	87,84	*75,54	96,92	*83,35	87,5	*75,25	96,25	*82,78
32	89,6	*77,06	99,2	*85,31	89,23	*76,74	98,46	*84,68	88,89	*76,45	97,78	*84,09
32,5	91	*78,26	100,75	*86,64	90,63	*77,94	100	*86	90,28	*77,64	99,31	*85,4
33	92,4	*79,46	102,3	*87,98	92,02	*79,14	101,54	*87,32	91,67	*78,83	100,83	*86,72
33,5	93,8	*80,67	103,85	*89,31	93,41	*80,34	103,08	*88,65	93,06	*80,03	102,36	*88,03
34	95,2	*81,87	105,4	*90,64	94,81	*81,54	104,61	*89,97	94,45	*81,22	103,89	*89,34
34,5	96,6	*83,08	106,95	*91,98	96,2	*82,73	106,15	*91,29	95,83	*82,42	105,42	*90,66
35	98	*84,28	108,5	*93,31	97,6	*83,93	107,69	*92,61	97,22	*83,61	106,94	*91,97
35,5	99,4	*85,48	110,05	*94,64	98,99	*85,13	109,23	*93,94	98,61	*84,81	108,47	*93,29
36	100,8	*86,69	111,6	*95,98	100,39	*86,33	110,77	*95,26	100	*86	110	*94,6
36,5	102,2	*87,89	113,15	*97,31	101,78	*87,53	112,31	*96,58	101,39	*87,2	111,53	*95,91
37	103,6	*89,1	114,7	*98,64	103,17	*88,73	113,85	*97,91	102,78	*88,39	113,06	*97,23
37,5	105	*90,3	116,25	*99,97	104,57	*89,93	115,38	*99,23	104,17	*89,58	114,58	*98,54
38	106,4	*91,5	117,8	*101,31	105,96	*91,13	116,92	*100,55	105,56	*90,78	116,11	*99,86
38,5	107,8	*92,71	119,35	*102,64	107,36	*92,33	118,46	*101,88	106,95	*91,97	117,64	*101,17
39	109,2	*93,91	120,9	*103,97	108,75	*93,53	120	*103,2	108,33	*93,17	119,17	*102,48
39,5	110,6	*95,12	122,45	*105,31	110,15	*94,73	121,54	*104,52	109,72	*94,36	120,69	*103,8
40	112	*96,32	124	*106,64	111,54	*95,92	123,08	*105,85	111,11	*95,56	122,22	*105,11
40,5	113,4	*97,52	125,55	*107,97	112,93	*97,12	124,61	*107,17	112,5	*96,75	123,75	*106,43
41	114,8	*98,73	127,1	*109,31	114,33	*98,32	126,15	*108,49	113,89	*97,95	125,28	*107,74
41,5	116,2	*99,93	128,65	*110,64	115,72	*99,52	127,69	*109,81	115,28	*99,14	126,81	*109,05
42	117,6	*101,14	130,2	*111,97	117,12	*100,72	129,23	*111,14	116,67	*100,33	128,33	*110,37
42,5	119	*102,34	131,75	*113,31	118,51	*101,92	130,77	*112,46	118,06	*101,53	129,86	*111,68
43	120,4	*103,54	133,3	*114,64	119,91	*103,12	132,31	*113,78	119,45	*102,72	131,39	*112,99
43,5	121,8	*104,75	134,85	*115,97	121,3	*104,32	133,85	*115,11	120,83	*103,92	132,92	*114,31
44	123,2	*105,95	136,4	*117,3	122,69	*105,52	135,38	*116,43	122,22	*105,11	134,44	*115,62
44,5	124,6	*107,16	137,95	*118,64	124,09	*106,72	136,92	*117,75	123,61	*106,31	135,97	*116,94
45	126	*108,36	139,5	*119,97	125,48	*107,91	138,46	*119,08	125	*107,5	137,5	*118,25
45,5	127,4	*109,56	141,05	*121,3	126,88	*109,11	140	*120,4	126,39	*108,7	139,03	*119,56
46	128,8	*110,77	142,6	*122,64	128,27	*110,31	141,54	*121,72	127,78	*109,89	140,56	*120,88
46,5	130,2	*111,97	144,15	*123,97	129,67	*111,51	143,08	*123,05	129,17	*111,08	142,08	*122,19

Total	Outdoor Unit Capacity Unit: kW (x1,000kcal/h)											
	RAS-50FSXN				RAS-52FSXN				RAS-54FSXN			
	Cooling		Heating		Cooling		Heating		Cooling		Heating	
47	131,6	*113,18	145,7	*125,3	131,06	*112,71	144,61	*124,37	130,56	*112,28	143,61	*123,51
47,5	133	*114,38	147,25	*126,64	132,45	*113,91	146,15	*125,69	131,95	*113,47	145,14	*124,82
48	134,4	*115,58	148,8	*127,97	133,85	*115,11	147,69	*127,01	133,33	*114,67	146,67	*126,13
48,5	135,8	*116,79	150,35	*129,3	135,24	*116,31	149,23	*128,34	134,72	*115,86	148,19	*127,45
49	137,2	*117,99	151,9	*130,63	136,64	*117,51	150,77	*129,66	136,11	*117,06	149,72	*128,76
49,5	138,6	*119,2	153,45	*131,97	138,03	*118,71	152,31	*130,98	137,5	*118,25	151,25	*130,08
50	140	*120,4	155	*133,3	139,43	*119,91	153,85	*132,31	138,89	*119,45	152,78	*131,39
50,5	140	*120,4	155	*133,3	140,82	*121,1	155,38	*133,63	140,28	*120,64	154,31	*132,7
51	140	*120,4	155	*133,3	142,21	*122,3	156,92	*134,95	141,67	*121,83	155,83	*134,02
51,5	140	*120,4	155	*133,3	143,61	*123,5	158,46	*136,28	143,06	*123,03	157,36	*135,33
52	140	*120,4	155	*133,3	145	*124,7	160	*137,6	144,45	*124,22	158,89	*136,64
52,5	140	*120,4	155	*133,3	145	*124,7	160	*137,6	145,83	*125,42	160,42	*137,96
53	140	*120,4	155	*133,3	145	*124,7	160	*137,6	147,22	*126,61	161,94	*139,27
53,5	140	*120,4	155	*133,3	145	*124,7	160	*137,6	148,61	*127,81	163,47	*140,59
54	140	*120,4	155	*133,3	145	*124,7	160	*137,6	150	*129	165	*141,9
54,5	140	*120,4	155	*133,3	145	*124,7	160	*137,6	150	*129	165	*141,9
55	140	*120,4	155	*133,3	145	*124,7	160	*137,6	150	*129	165	*141,9
55,5	140	*120,4	155	*133,3	145	*124,7	160	*137,6	150	*129	165	*141,9
56	140	*120,4	155	*133,3	145	*124,7	160	*137,6	150	*129	165	*141,9
56,5	140	*120,4	155	*133,3	145	*124,7	160	*137,6	150	*129	165	*141,9
57	140	*120,4	155	*133,3	145	*124,7	160	*137,6	150	*129	165	*141,9
57,5	140	*120,4	155	*133,3	145	*124,7	160	*137,6	150	*129	165	*141,9
58	140	*120,4	155	*133,3	145	*124,7	160	*137,6	150	*129	165	*141,9
58,5	140	*120,4	155	*133,3	145	*124,7	160	*137,6	150	*129	165	*141,9
59	140	*120,4	155	*133,3	145	*124,7	160	*137,6	150	*129	165	*141,9
59,5	140	*120,4	155	*133,3	145	*124,7	160	*137,6	150	*129	165	*141,9
60	140	*120,4	155	*133,3	145	*124,7	160	*137,6	150	*129	165	*141,9
60,5	140	*120,4	155	*133,3	145	*124,7	160	*137,6	150	*129	165	*141,9
61	140	*120,4	155	*133,3	145	*124,7	160	*137,6	150	*129	165	*141,9
61,5	140	*120,4	155	*133,3	145	*124,7	160	*137,6	150	*129	165	*141,9
62	140	*120,4	155	*133,3	145	*124,7	160	*137,6	150	*129	165	*141,9
62,5	140	*120,4	155	*133,3	145	*124,7	160	*137,6	150	*129	165	*141,9
63	140	*120,4	155	*133,3	145	*124,7	160	*137,6	150	*129	165	*141,9
63,5	140	*120,4	155	*133,3	145	*124,7	160	*137,6	150	*129	165	*141,9
64	140	*120,4	155	*133,3	145	*124,7	160	*137,6	150	*129	165	*141,9
64,5	140	*120,4	155	*133,3	145	*124,7	160	*137,6	150	*129	165	*141,9
65	140	*120,4	155	*133,3	145	*124,7	160	*137,6	150	*129	165	*141,9

Total	Outdoor Unit Capacity Unit: kW (x1,000kcal/h)									
	RAS-50FSXN		RAS-52FSXN				RAS-54FSXN			
	Cooling	Heating	Cooling		Heating		Cooling		Heating	
65,5	—	—	145	*124,7	160	*137,6	150	*129	165	*141,9
66			145	*124,7	160	*137,6	150	*129	165	*141,9
66,5			145	*124,7	160	*137,6	150	*129	165	*141,9
67			145	*124,7	160	*137,6	150	*129	165	*141,9
67,5			145	*124,7	160	*137,6	150	*129	165	*141,9
68			150	*129	165	*141,9	—		—	
68,5			150	*129	165	*141,9	—		—	
69			150	*129	165	*141,9	—		—	
69,5			150	*129	165	*141,9	—		—	
70			150	*129	165	*141,9	—		—	

## 4.6 Tables for 100% combination cooling capacity



### NOTE

- **DB: dry bulb; WB: wet bulb.**
- **The table shows the normal cooling operation value. In some cases, the value may change due to the compressor protection control.**
- **The cooling capacity of the tables indicates the peak value, which does not include the capacity loss due to frost.**
- **The values shown in the tables occur in the following conditions: the total capacity of the indoor units corresponds to 100% of the capacity of the outdoor unit. The total length of the refrigerant pipes is 7.5 m. The difference in height between the outdoor unit and the indoor units is 0 m.**
- **In the case of heat recovery systems, the values in the tables are indicated for all the indoor units operating in refrigeration mode.**

Table 1. Cooling capacity for RAS-8FSXN

Capacity unit: kW (Correction factor)						
Outdoor air inlet °C (DB)	Indoor air inlet °C (WB)					
	16.0	18.0	19.0	20.0	22.0	23.0
25.0	19.3	21.4	22.4	23.3	24.6	25.1
	(0.86)	(0.96)	(1.00)	(1.04)	(1.10)	(1.12)
30.0	19.3	21.4	22.4	23.3	24.6	25.1
	(0.86)	(0.96)	(1.00)	(1.04)	(1.10)	(1.12)
35.0	19.3	21.4	22.4	23.3	24.6	25.1
	(0.86)	(0.96)	(1.00)	(1.04)	(1.10)	(1.12)
40.0	19.0	20.7	21.5	22.3	23.3	23.6
	(0.85)	(0.93)	(0.96)	(1.00)	(1.04)	(1.06)

Table 2. Cooling capacity for RAS-10FSXN

Capacity unit: kW (Correction factor)						
Outdoor air inlet °C (DB)	Indoor air inlet °C (WB)					
	16.0	18.0	19.0	20.0	22.0	23.0
25.0	24.2	26.7	28.0	29.1	30.7	31.4
	(0.86)	(0.96)	(1.00)	(1.04)	(1.10)	(1.12)
30.0	24.2	26.7	28.0	29.1	30.7	31.4
	(0.86)	(0.96)	(1.00)	(1.04)	(1.10)	(1.12)
35.0	24.2	26.7	28.0	29.1	30.7	31.4
	(0.86)	(0.96)	(1.00)	(1.04)	(1.10)	(1.12)
40.0	23.5	25.6	26.6	27.5	28.6	29.0
	(0.84)	(0.92)	(0.95)	(0.98)	(1.02)	(1.04)



Table 3. Cooling capacity for RAS-12FSXN

Capacity unit: kW (Correction factor)						
Outdoor air inlet °C (DB)	Indoor air inlet °C (WB)					
	16.0	18.0	19.0	20.0	22.0	23.0
25.0	28.9	32.0	33.5	34.8	36.7	37.5
	(0.86)	(0.96)	(1.00)	(1.04)	(1.10)	(1.12)
30.0	28.9	32.0	33.5	34.8	36.7	37.5
	(0.86)	(0.96)	(1.00)	(1.04)	(1.10)	(1.12)
35.0	28.9	32.0	33.5	34.8	36.3	36.8
	(0.86)	(0.96)	(1.00)	(1.04)	(1.09)	(1.10)
40.0	27.8	30.3	31.2	32.0	32.8	33.2
	(0.83)	(0.91)	(0.93)	(0.95)	(0.98)	(0.99)

Table 4. Cooling capacity for RAS-14FSXN

Capacity unit: kW (Correction factor)						
Outdoor air inlet °C (DB)	Indoor air inlet °C (WB)					
	16.0	18.0	19.0	20.0	22.0	23.0
25.0	34.5	38.2	40.0	41.6	43.8	44.8
	(0.86)	(0.96)	(1.00)	(1.04)	(1.10)	(1.12)
30.0	34.5	38.2	40.0	41.6	43.8	44.8
	(0.86)	(0.96)	(1.00)	(1.04)	(1.10)	(1.12)
35.0	34.5	38.2	40.0	41.6	43.4	43.9
	(0.86)	(0.96)	(1.00)	(1.04)	(1.09)	(1.10)
40.0	33.2	36.2	37.2	38.2	39.2	39.7
	(0.83)	(0.91)	(0.93)	(0.95)	(0.98)	(0.99)

Table 5. Cooling capacity for RAS-16FSXN

Capacity unit: kW (Correction factor)						
Outdoor air inlet °C (DB)	Indoor air inlet °C (WB)					
	16.0	18.0	19.0	20.0	22.0	23.0
25.0	38.8	43.0	45.0	46.8	49.3	50.4
	(0.86)	(0.96)	(1.00)	(1.04)	(1.10)	(1.12)
30.0	38.8	43.0	45.0	46.8	49.3	50.4
	(0.86)	(0.96)	(1.00)	(1.04)	(1.10)	(1.12)
35.0	38.8	43.0	45.0	46.4	48.1	48.6
	(0.86)	(0.96)	(1.00)	(1.03)	(1.07)	(1.08)
40.0	36.9	39.9	41.0	41.6	42.3	42.5
	(0.82)	(0.89)	(0.91)	(0.92)	(0.94)	(0.95)

Table 6. Cooling capacity for RAS-18FSXN

Capacity unit: kW (Correction factor)						
Outdoor air inlet °C (DB)	Indoor air inlet °C (WB)					
	16.0	18.0	19.0	20.0	22.0	23.0
25.0	43.2	47.8	50.0	52.0	54.8	56.0
	(0.86)	(0.96)	(1.00)	(1.04)	(1.10)	(1.12)
30.0	43.2	47.8	50.0	52.0	54.8	56.0
	(0.86)	(0.96)	(1.00)	(1.04)	(1.10)	(1.12)
35.0	43.2	47.8	50.0	51.5	53.4	54.0
	(0.86)	(0.96)	(1.00)	(1.03)	(1.07)	(1.08)
40.0	41.0	44.3	45.5	46.2	47.0	47.3
	(0.82)	(0.89)	(0.91)	(0.92)	(0.94)	(0.95)

Table 7. Cooling capacity for RAS-20FSXN

Capacity unit: kW (Correction factor)						
Outdoor air inlet °C (DB)	Indoor air inlet °C (WB)					
	16.0	18.0	19.0	20.0	22.0	23.0
25.0	48.2	53.4	56.0	58.1	61.3	62.6
	(0.86)	(0.95)	(1.00)	(1.04)	(1.09)	(1.12)
30.0	48.2	53.4	56.0	58.1	61.3	62.6
	(0.86)	(0.95)	(1.00)	(1.04)	(1.09)	(1.12)
35.0	48.2	53.4	56.0	58.1	60.9	61.9
	(0.86)	(0.95)	(1.00)	(1.04)	(1.09)	(1.10)
40.0	46.8	51.0	52.7	54.2	56.1	56.9
	(0.84)	(0.91)	(0.94)	(0.97)	(1.00)	(1.02)

Table 8. Cooling capacity for RAS-22FSXN

Capacity unit: kW (Correction factor)						
Outdoor air inlet °C (DB)	Indoor air inlet °C (WB)					
	16.0	18.0	19.0	20.0	22.0	23.0
25.0	53.2	59.0	61.5	64.2	68.0	69.6
	(0.87)	(0.96)	(1.00)	(1.04)	(1.11)	(1.13)
30.0	53.2	59.0	61.5	64.2	68.0	69.6
	(0.87)	(0.96)	(1.00)	(1.04)	(1.11)	(1.13)
35.0	53.2	59.0	61.5	64.2	68.0	69.0
	(0.87)	(0.96)	(1.00)	(1.04)	(1.10)	(1.12)
40.0	52.2	56.9	58.7	60.4	62.5	63.3
	(0.85)	(0.93)	(0.95)	(0.98)	(1.02)	(1.03)

Table 9. Cooling capacity for RAS-24FSXN

Capacity unit: kW (Correction factor)						
Outdoor air inlet °C (DB)	Indoor air inlet °C (WB)					
	16.0	18.0	19.0	20.0	22.0	23.0
25.0	58.7	65.5	69.0	71.5	75.0	76.3
	(0.85)	(0.95)	(1.00)	(1.04)	(1.09)	(1.11)
30.0	58.7	65.5	69.0	71.5	75.0	76.3
	(0.85)	(0.95)	(1.00)	(1.04)	(1.09)	(1.11)
35.0	58.7	65.5	69.0	71.0	74.1	75.3
	(0.85)	(0.95)	(1.00)	(1.03)	(1.07)	(1.09)
40.0	56.7	61.8	63.8	65.7	67.8	68.7
	(0.82)	(0.90)	(0.92)	(0.95)	(0.98)	(1.00)

Table 10. Cooling capacity for RAS-26FSXN

Capacity unit: kW (Correction factor)						
Outdoor air inlet °C (DB)	Indoor air inlet °C (WB)					
	16.0	18.0	19.0	20.0	22.0	23.0
25.0	63.4	70.2	73.0	76.0	80.3	82.2
	(0.87)	(0.96)	(1.00)	(1.04)	(1.10)	(1.13)
30.0	63.4	70.2	73.0	76.0	80.3	82.2
	(0.87)	(0.96)	(1.00)	(1.04)	(1.10)	(1.13)
35.0	63.4	70.2	73.0	76.0	79.7	80.7
	(0.87)	(0.96)	(1.00)	(1.04)	(1.09)	(1.11)
40.0	61.0	66.5	68.4	70.1	72.0	72.9
	(0.84)	(0.91)	(0.94)	(0.96)	(0.99)	(1.00)

Table 11. Cooling capacity for RAS-28FSXN

Capacity unit: kW (Correction factor)						
Outdoor air inlet °C (DB)	Indoor air inlet °C (WB)					
	16.0	18.0	19.0	20.0	22.0	23.0
25.0	69.0	76.4	80.0	83.2	87.7	89.6
	(0.86)	(0.96)	(1.00)	(1.04)	(1.10)	(1.12)
30.0	69.0	76.4	80.0	83.2	87.7	89.6
	(0.86)	(0.96)	(1.00)	(1.04)	(1.10)	(1.12)
35.0	69.0	76.4	80.0	83.2	86.8	87.8
	(0.86)	(0.96)	(1.00)	(1.04)	(1.09)	(1.10)
40.0	66.4	72.4	74.4	76.3	78.4	79.4
	(0.83)	(0.91)	(0.93)	(0.95)	(0.98)	(0.99)

Table 12. Cooling capacity for RAS-30FSXN

Capacity unit: kW (Correction factor)						
Outdoor air inlet °C (DB)	Indoor air inlet °C (WB)					
	16.0	18.0	19.0	20.0	22.0	23.0
25.0	73.4	81.2	85.0	88.4	93.2	95.2
	(0.86)	(0.96)	(1.00)	(1.04)	(1.10)	(1.12)
30.0	73.4	81.2	85.0	88.4	93.2	95.2
	(0.86)	(0.96)	(1.00)	(1.04)	(1.10)	(1.12)
35.0	73.4	81.2	85.0	88.0	91.5	92.5
	(0.86)	(0.96)	(1.00)	(1.03)	(1.08)	(1.09)
40.0	70.1	76.1	78.2	79.7	81.5	82.2
	(0.82)	(0.89)	(0.92)	(0.94)	(0.96)	(0.97)

Table 13. Cooling capacity for RAS-32FSXN

Capacity unit: kW (Correction factor)						
Outdoor air inlet °C (DB)	Indoor air inlet °C (WB)					
	16.0	18.0	19.0	20.0	22.0	23.0
25.0	77.7	86.0	90.0	93.6	98.6	100.8
	(0.86)	(0.96)	(1.00)	(1.04)	(1.10)	(1.12)
30.0	77.7	86.0	90.0	93.6	98.6	100.8
	(0.86)	(0.96)	(1.00)	(1.04)	(1.10)	(1.12)
35.0	77.7	86.0	90.0	92.7	96.1	97.2
	(0.86)	(0.96)	(1.00)	(1.03)	(1.07)	(1.08)
40.0	73.8	79.7	81.9	83.2	84.6	85.1
	(0.82)	(0.89)	(0.91)	(0.92)	(0.94)	(0.95)

Table 14. Cooling capacity for RAS-34FSXN

Capacity unit: kW (Correction factor)						
Outdoor air inlet °C (DB)	Indoor air inlet °C (WB)					
	16.0	18.0	19.0	20.0	22.0	23.0
25.0	82.0	90.7	95.0	98.8	104.1	106.4
	(0.86)	(0.96)	(1.00)	(1.04)	(1.10)	(1.12)
30.0	82.0	90.7	95.0	98.8	104.1	106.4
	(0.86)	(0.96)	(1.00)	(1.04)	(1.10)	(1.12)
35.0	82.0	90.7	95.0	97.9	101.5	102.6
	(0.86)	(0.96)	(1.00)	(1.03)	(1.07)	(1.08)
40.0	77.9	84.2	86.5	87.8	89.3	89.8
	(0.82)	(0.89)	(0.91)	(0.92)	(0.94)	(0.95)

Table 15. Cooling capacity for RAS-36FSXN

Capacity unit: kW (Correction factor)						
Outdoor air inlet °C (DB)	Indoor air inlet °C (WB)					
	16.0	18.0	19.0	20.0	22.0	23.0
25.0	86.3	95.5	100.0	104.0	109.6	112.0
	(0.86)	(0.96)	(1.00)	(1.04)	(1.10)	(1.12)
30.0	86.3	95.5	100.0	104.0	109.6	112.0
	(0.86)	(0.96)	(1.00)	(1.04)	(1.10)	(1.12)
35.0	86.3	95.5	100.0	103.0	106.8	108.0
	(0.86)	(0.96)	(1.00)	(1.03)	(1.07)	(1.08)
40.0	82.0	88.6	91.0	92.4	94.0	94.5
	(0.82)	(0.89)	(0.91)	(0.92)	(0.94)	(0.95)

Table 16. Cooling capacity for RAS-38FSXN

Capacity unit: kW (Correction factor)						
Outdoor air inlet °C (DB)	Indoor air inlet °C (WB)					
	16.0	18.0	19.0	20.0	22.0	23.0
25.0	92.3	103.5	109.0	112.5	117.8	120.2
	(0.85)	(0.95)	(1.00)	(1.03)	(1.08)	(1.10)
30.0	92.3	103.5	109.0	112.5	117.8	120.2
	(0.85)	(0.95)	(1.00)	(1.03)	(1.08)	(1.10)
35.0	92.3	103.5	109.0	112.0	116.1	117.5
	(0.85)	(0.95)	(1.00)	(1.03)	(1.07)	(1.08)
40.0	88.8	96.8	99.5	102.1	104.9	106.1
	(0.81)	(0.89)	(0.91)	(0.94)	(0.96)	(0.97)

Table 17. Cooling capacity for RAS-40FSXN

Capacity unit: kW (Correction factor)						
Outdoor air inlet °C (DB)	Indoor air inlet °C (WB)					
	16.0	18.0	19.0	20.0	22.0	23.0
25.0	96.7	107.0	112.0	116.5	122.8	125.4
	(0.86)	(0.96)	(1.00)	(1.04)	(1.10)	(1.12)
30.0	96.7	107.0	112.0	116.5	122.8	125.4
	(0.86)	(0.96)	(1.00)	(1.04)	(1.10)	(1.12)
35.0	96.7	107.0	112.0	116.0	120.8	122.2
	(0.86)	(0.96)	(1.00)	(1.04)	(1.08)	(1.09)
40.0	92.5	100.5	103.3	105.5	108.0	109.0
	(0.83)	(0.90)	(0.92)	(0.94)	(0.96)	(0.97)

Table 18. Cooling capacity for RAS-42FSXN

Capacity unit: kW (Correction factor)						
Outdoor air inlet °C (DB)	Indoor air inlet °C (WB)					
	16.0	18.0	19.0	20.0	22.0	23.0
25.0	101.0	112.5	118.0	122.0	128.2	131.0
	(0.86)	(0.95)	(1.00)	(1.03)	(1.09)	(1.11)
30.0	101.0	112.5	118.0	122.0	128.2	131.0
	(0.86)	(0.95)	(1.00)	(1.03)	(1.09)	(1.11)
35.0	101.0	112.5	118.0	121.2	126.1	127.6
	(0.86)	(0.95)	(1.00)	(1.03)	(1.07)	(1.08)
40.0	96.6	104.9	107.8	110.1	112.7	113.7
	(0.82)	(0.89)	(0.91)	(0.93)	(0.95)	(0.96)

Table 19. Cooling capacity for RAS-44FSXN

Capacity unit: kW (Correction factor)						
Outdoor air inlet °C (DB)	Indoor air inlet °C (WB)					
	16.0	18.0	19.0	20.0	22.0	23.0
25.0	106.6	118.5	125.0	129.0	135.4	138.3
	(0.85)	(0.95)	(1.00)	(1.03)	(1.08)	(1.11)
30.0	106.6	118.5	125.0	129.0	135.4	138.3
	(0.85)	(0.95)	(1.00)	(1.03)	(1.08)	(1.11)
35.0	106.6	118.5	125.0	127.9	133.1	134.7
	(0.85)	(0.95)	(1.00)	(1.02)	(1.07)	(1.08)
40.0	102.0	110.8	113.9	116.3	119.0	120.2
	(0.82)	(0.89)	(0.91)	(0.93)	(0.95)	(0.96)

Table 20. Cooling capacity for RAS-46FSXN

Capacity unit: kW (Correction factor)						
Outdoor air inlet °C (DB)	Indoor air inlet °C (WB)					
	16.0	18.0	19.0	20.0	22.0	23.0
25.0	112.0	125.5	132.0	136.5	143.0	145.8
	(0.85)	(0.95)	(1.00)	(1.03)	(1.08)	(1.10)
30.0	112.0	125.5	132.0	136.5	143.0	145.8
	(0.85)	(0.95)	(1.00)	(1.03)	(1.08)	(1.10)
35.0	112.0	125.5	132.0	134.5	137.8	139.4
	(0.85)	(0.95)	(1.00)	(1.02)	(1.04)	(1.06)
40.0	105.7	114.5	117.6	119.7	122.1	123.0
	(0.80)	(0.87)	(0.89)	(0.91)	(0.93)	(0.93)

Table 21. Cooling capacity for RAS-48FSXN

Capacity unit: kW (Correction factor)						
Outdoor air inlet °C (DB)	Indoor air inlet °C (WB)					
	16.0	18.0	19.0	20.0	22.0	23.0
25.0	115.2	129.0	136.0	141.0	147.2	150.0
	(0.85)	(0.95)	(1.00)	(1.04)	(1.08)	(1.10)
30.0	115.2	129.0	136.0	141.0	147.2	150.0
	(0.85)	(0.95)	(1.00)	(1.04)	(1.08)	(1.10)
35.0	115.2	129.0	136.0	139.0	143.1	144.8
	(0.85)	(0.95)	(1.00)	(1.02)	(1.05)	(1.06)
40.0	109.8	118.9	122.2	124.4	126.8	127.7
	(0.81)	(0.87)	(0.90)	(0.91)	(0.93)	(0.94)

Table 22. Cooling capacity for RAS-50FSXN

Capacity unit: kW (Correction factor)						
Outdoor air inlet °C (DB)	Indoor air inlet °C (WB)					
	16.0	18.0	19.0	20.0	22.0	23.0
25.0	120.8	133.7	140.0	145.6	153.4	156.8
	(0.86)	(0.96)	(1.00)	(1.04)	(1.10)	(1.12)
30.0	120.8	133.7	140.0	145.6	153.4	156.8
	(0.86)	(0.96)	(1.00)	(1.04)	(1.10)	(1.12)
35.0	120.8	133.7	140.0	144.6	150.2	151.9
	(0.86)	(0.96)	(1.00)	(1.03)	(1.07)	(1.09)
40.0	115.2	124.8	128.2	130.6	133.2	134.2
	(0.82)	(0.89)	(0.92)	(0.93)	(0.95)	(0.96)

Table 23. Cooling capacity for RAS-52FSXN

Capacity unit: kW (Correction factor)						
Outdoor air inlet °C (DB)	Indoor air inlet °C (WB)					
	16.0	18.0	19.0	20.0	22.0	23.0
25.0	125.1	138.5	145.0	150.8	158.9	162.4
	(0.86)	(0.96)	(1.00)	(1.04)	(1.10)	(1.12)
30.0	125.1	138.5	145.0	150.8	158.9	162.4
	(0.86)	(0.96)	(1.00)	(1.04)	(1.10)	(1.12)
35.0	125.1	138.5	145.0	149.4	154.9	156.6
	(0.86)	(0.96)	(1.00)	(1.03)	(1.07)	(1.08)
40.0	118.9	128.5	132.0	134.0	136.3	137.0
	(0.82)	(0.89)	(0.91)	(0.92)	(0.94)	(0.95)

Table 24. Cooling capacity for RAS-54FSXN

Capacity unit: kW (Correction factor)						
Outdoor air inlet °C (DB)	Indoor air inlet °C (WB)					
	16.0	18.0	19.0	20.0	22.0	23.0
25.0	129.5	143.3	150.0	156.0	164.4	168.0
	(0.86)	(0.96)	(1.00)	(1.04)	(1.10)	(1.12)
30.0	129.5	143.3	150.0	156.0	164.4	168.0
	(0.86)	(0.96)	(1.00)	(1.04)	(1.10)	(1.12)
35.0	129.5	143.3	150.0	154.5	160.2	162.0
	(0.86)	(0.96)	(1.00)	(1.03)	(1.07)	(1.08)
40.0	123.0	132.9	136.5	138.6	141.0	141.8
	(0.82)	(0.89)	(0.91)	(0.92)	(0.94)	(0.95)



## 4.7 Tables for 100% combination heating capacity



### NOTE

- **DB: dry bulb; WB: wet bulb.**
- **The table shows the normal heating operation value. In some cases, the value may change due to the compressor protection control.**
- **The heating capacity of the tables indicates the peak value, which does not include the capacity loss due to frost.**
- **The values shown in the tables occur in the following conditions: the total capacity of the indoor units corresponds to 100% of the capacity of the outdoor unit. The total length of the refrigerant pipes is 7.5 m. The difference in height between the outdoor unit and the indoor units is 0 m.**
- **In the case of heat recovery systems, the values in the tables are indicated for all the indoor units operating in refrigeration mode.**

Table 1. Heating capacity for RAS-8FSXN						
Capacity unit: kW (Correction factor)						
Outdoor air inlet °C (DB)	Indoor air inlet °C (WB)					
	16.0	18.0	20.0	21.0	22.0	24.0
-10.0	19.5	19.5	19.5	19.5	19.5	19.4
	(0.78)	(0.78)	(0.78)	(0.78)	(0.78)	(0.78)
-5.0	22.1	22.0	22.0	21.9	21.9	21.5
	(0.88)	(0.88)	(0.88)	(0.88)	(0.87)	(0.86)
0.0	24.5	24.3	24.0	23.8	23.4	22.0
	(0.98)	(0.97)	(0.96)	(0.95)	(0.94)	(0.88)
5.0	25.9	25.5	24.8	24.4	23.9	22.0
	(1.04)	(1.02)	(0.99)	(0.98)	(0.96)	(0.88)
6.0	26.5	25.8	25.0	24.6	23.9	22.0
	(1.06)	(1.03)	(1.00)	(0.98)	(0.95)	(0.88)
10.0	28.3	27.0	25.5	24.7	23.9	22.0
	(1.13)	(1.08)	(1.02)	(0.99)	(0.95)	(0.88)
15.0	28.3	27.0	25.5	24.7	23.9	22.0
	(1.13)	(1.08)	(1.02)	(0.99)	(0.95)	(0.88)

Table 2. Heating capacity for RAS-10FSXN

Capacity unit: kW (Correction factor)						
Outdoor air inlet °C (DB)	Indoor air inlet °C (WB)					
	16.0	18.0	20.0	21.0	22.0	24.0
-10.0	22.7	22.7	22.7	22.7	22.6	22.6
	(0.72)	(0.72)	(0.72)	(0.72)	(0.72)	(0.72)
-5.0	26.0	26.0	25.9	25.8	25.8	25.6
	(0.83)	(0.82)	(0.82)	(0.82)	(0.82)	(0.81)
0.0	28.8	28.7	28.7	28.5	28.4	27.5
	(0.91)	(0.91)	(0.91)	(0.91)	(0.90)	(0.87)
5.0	31.8	31.5	31.2	30.8	29.9	27.7
	(1.01)	(1.00)	(0.99)	(0.98)	(0.95)	(0.88)
6.0	32.9	32.3	31.5	31.0	30.1	27.7
	(1.05)	(1.03)	(1.00)	(0.98)	(0.95)	(0.88)
10.0	34.5	33.8	32.1	31.2	30.1	27.7
	(1.10)	(1.07)	(1.02)	(0.99)	(0.95)	(0.88)
15.0	35.7	34.0	32.1	31.2	30.1	27.7
	(1.13)	(1.08)	(1.02)	(0.99)	(0.95)	(0.88)

Table 3. Heating capacity for RAS-12FSXN

Capacity unit: kW (Correction factor)						
Outdoor air inlet °C (DB)	Indoor air inlet °C (WB)					
	16.0	18.0	20.0	21.0	22.0	24.0
-10.0	24.4	24.4	24.4	24.4	24.3	24.2
	(0.65)	(0.65)	(0.65)	(0.65)	(0.65)	(0.65)
-5.0	28.7	28.7	28.7	28.7	28.6	28.4
	(0.77)	(0.77)	(0.77)	(0.76)	(0.76)	(0.76)
0.0	33.0	33.0	33.0	32.9	32.8	31.9
	(0.88)	(0.88)	(0.88)	(0.88)	(0.87)	(0.85)
5.0	36.9	36.9	36.6	36.2	35.5	33.0
	(0.98)	(0.98)	(0.98)	(0.97)	(0.95)	(0.88)
6.0	38.1	38.1	37.5	36.9	35.8	33.0
	(1.02)	(1.02)	(1.00)	(0.98)	(0.95)	(0.88)
10.0	40.5	39.6	38.3	37.1	35.8	33.0
	(1.08)	(1.06)	(1.02)	(0.99)	(0.95)	(0.88)
15.0	42.5	40.6	38.3	37.1	35.8	33.0
	(1.13)	(1.08)	(1.02)	(0.99)	(0.95)	(0.88)

Table 4. Heating capacity for RAS-14FSXN

Capacity unit: kW (Correction factor)						
Outdoor air inlet °C (DB)	Indoor air inlet °C (WB)					
	16.0	18.0	20.0	21.0	22.0	24.0
-10.0	32.4	32.4	32.4	32.4	32.3	32.2
	(0.72)	(0.72)	(0.72)	(0.72)	(0.72)	(0.72)
-5.0	37.2	37.1	37.0	36.9	36.8	36.6
	(0.83)	(0.82)	(0.82)	(0.82)	(0.82)	(0.81)
0.0	41.1	41.0	41.0	40.8	40.5	39.3
	(0.91)	(0.91)	(0.91)	(0.91)	(0.90)	(0.87)
5.0	45.4	45.0	44.6	44.0	42.8	39.6
	(1.01)	(1.00)	(0.99)	(0.98)	(0.95)	(0.88)
6.0	47.1	46.2	45.0	44.3	43.0	39.6
	(1.05)	(1.03)	(1.00)	(0.98)	(0.95)	(0.88)
10.0	49.3	48.3	45.9	44.5	43.0	39.6
	(1.10)	(1.07)	(1.02)	(0.99)	(0.95)	(0.88)
15.0	51.0	48.7	45.9	44.5	43.0	39.6
	(1.13)	(1.08)	(1.02)	(0.99)	(0.95)	(0.88)

Table 5. Heating capacity for RAS-16FSXN

Capacity unit: kW (Correction factor)						
Outdoor air inlet °C (DB)	Indoor air inlet °C (WB)					
	16.0	18.0	20.0	21.0	22.0	24.0
-10.0	35.0	35.0	35.0	35.0	34.9	34.8
	(0.70)	(0.70)	(0.70)	(0.70)	(0.70)	(0.70)
-5.0	40.3	40.2	40.1	40.0	39.9	39.7
	(0.81)	(0.80)	(0.80)	(0.80)	(0.80)	(0.79)
0.0	45.3	45.2	45.1	44.9	44.6	43.4
	(0.91)	(0.90)	(0.90)	(0.90)	(0.89)	(0.87)
5.0	50.2	49.8	49.3	48.8	47.4	44.0
	(1.00)	(1.00)	(0.99)	(0.98)	(0.95)	(0.88)
6.0	52.2	51.4	50.0	49.2	47.7	44.0
	(1.04)	(1.03)	(1.00)	(0.98)	(0.95)	(0.88)
10.0	54.8	53.7	51.0	49.5	47.7	44.0
	(1.10)	(1.07)	(1.02)	(0.99)	(0.95)	(0.88)
15.0	56.7	54.2	51.0	49.5	47.7	44.0
	(1.13)	(1.08)	(1.02)	(0.99)	(0.95)	(0.88)

Table 6. Heating capacity for RAS-18FSXN

Capacity unit: kW (Correction factor)						
Outdoor air inlet °C (DB)	Indoor air inlet °C (WB)					
	16.0	18.0	20.0	21.0	22.0	24.0
-10.0	39.2	39.2	39.2	39.2	39.1	39.0
	(0.70)	(0.70)	(0.70)	(0.70)	(0.70)	(0.70)
-5.0	45.1	45.0	44.9	44.8	44.7	44.5
	(0.81)	(0.80)	(0.80)	(0.80)	(0.80)	(0.79)
0.0	50.7	50.6	50.5	50.3	50.0	48.6
	(0.91)	(0.90)	(0.90)	(0.90)	(0.89)	(0.87)
5.0	56.2	55.8	55.2	54.7	53.1	49.3
	(1.00)	(1.00)	(0.99)	(0.98)	(0.95)	(0.88)
6.0	58.5	57.6	56.0	55.1	53.5	49.3
	(1.04)	(1.03)	(1.00)	(0.98)	(0.95)	(0.88)
10.0	61.4	60.1	57.1	55.4	53.5	49.3
	(1.10)	(1.07)	(1.02)	(0.99)	(0.95)	(0.88)
15.0	63.5	60.6	57.1	55.4	53.5	49.3
	(1.13)	(1.08)	(1.02)	(0.99)	(0.95)	(0.88)

Table 7. Heating capacity for RAS-20FSXN

Capacity unit: kW (Correction factor)						
Outdoor air inlet °C (DB)	Indoor air inlet °C (WB)					
	16.0	18.0	20.0	21.0	22.0	24.0
-10.0	43.9	43.9	43.9	43.9	43.8	43.6
	(0.70)	(0.70)	(0.70)	(0.70)	(0.69)	(0.69)
-5.0	50.8	50.7	50.7	50.6	50.4	49.8
	(0.81)	(0.81)	(0.80)	(0.80)	(0.80)	(0.79)
0.0	57.5	57.3	57.0	56.7	56.2	53.9
	(0.91)	(0.91)	(0.90)	(0.90)	(0.89)	(0.86)
5.0	62.8	62.4	61.4	60.6	59.4	55.0
	(1.00)	(0.99)	(0.97)	(0.96)	(0.94)	(0.87)
6.0	64.6	64.0	63.0	61.5	59.7	55.0
	(1.02)	(1.02)	(1.00)	(0.98)	(0.95)	(0.87)
10.0	68.8	66.6	63.8	61.8	59.7	55.0
	(1.09)	(1.06)	(1.01)	(0.98)	(0.95)	(0.87)
15.0	70.8	67.6	63.8	61.8	59.7	55.0
	(1.12)	(1.07)	(1.01)	(0.98)	(0.95)	(0.87)

Table 8. Heating capacity for RAS-22FSXN

Capacity unit: kW (Correction factor)						
Outdoor air inlet °C (DB)	Indoor air inlet °C (WB)					
	16.0	18.0	20.0	21.0	22.0	24.0
-10.0	51.9	51.9	51.9	51.9	51.8	51.6
	(0.75)	(0.75)	(0.75)	(0.75)	(0.75)	(0.75)
-5.0	59.2	59.1	58.9	58.8	58.7	58.1
	(0.86)	(0.86)	(0.85)	(0.85)	(0.85)	(0.84)
0.0	65.6	65.3	65.0	64.6	63.9	60.7
	(0.95)	(0.95)	(0.94)	(0.94)	(0.93)	(0.88)
5.0	70.8	69.8	68.4	67.6	65.9	60.7
	(1.03)	(1.01)	(0.99)	(0.98)	(0.96)	(0.88)
6.0	72.8	71.0	69.0	67.6	65.9	60.7
	(1.06)	(1.03)	(1.00)	(0.98)	(0.96)	(0.88)
10.0	76.5	74.7	70.4	68.3	65.9	60.7
	(1.11)	(1.08)	(1.02)	(0.99)	(0.96)	(0.88)
15.0	78.2	74.7	70.4	68.3	65.9	60.7
	(1.13)	(1.08)	(1.02)	(0.99)	(0.96)	(0.88)

Table 9. Heating capacity for RAS-24FSXN

Capacity unit: kW (Correction factor)						
Outdoor air inlet °C (DB)	Indoor air inlet °C (WB)					
	16.0	18.0	20.0	21.0	22.0	24.0
-10.0	55.1	55.1	55.1	55.1	54.9	54.8
	(0.71)	(0.71)	(0.71)	(0.71)	(0.71)	(0.71)
-5.0	63.2	63.0	62.9	62.7	62.6	62.3
	(0.82)	(0.81)	(0.81)	(0.81)	(0.81)	(0.80)
0.0	69.9	69.8	69.6	69.3	68.9	66.8
	(0.90)	(0.90)	(0.90)	(0.89)	(0.89)	(0.86)
5.0	77.1	76.5	75.7	74.8	72.7	67.3
	(0.99)	(0.99)	(0.98)	(0.97)	(0.94)	(0.87)
6.0	80.0	79.0	77.5	75.5	73.0	67.3
	(1.03)	(1.02)	(1.00)	(0.97)	(0.94)	(0.87)
10.0	83.8	82.1	78.0	75.7	73.0	67.3
	(1.08)	(1.06)	(1.01)	(0.98)	(0.94)	(0.87)
15.0	86.7	82.8	78.0	75.7	73.0	67.3
	(1.12)	(1.07)	(1.01)	(0.98)	(0.94)	(0.87)

Table 10. Heating capacity for RAS-26FSXN

Capacity unit: kW (Correction factor)						
Outdoor air inlet °C (DB)	Indoor air inlet °C (WB)					
	16.0	18.0	20.0	21.0	22.0	24.0
-10.0	56.8	56.8	56.8	56.8	56.6	56.4
	(0.69)	(0.69)	(0.69)	(0.69)	(0.69)	(0.68)
-5.0	65.9	65.8	65.7	65.6	65.4	65.0
	(0.80)	(0.80)	(0.80)	(0.79)	(0.79)	(0.79)
0.0	74.1	74.0	74.0	73.7	73.3	71.2
	(0.90)	(0.90)	(0.90)	(0.89)	(0.89)	(0.86)
5.0	82.3	81.9	81.2	80.2	78.2	72.6
	(1.00)	(0.99)	(0.98)	(0.97)	(0.95)	(0.88)
6.0	85.1	84.2	82.5	81.2	78.8	72.6
	(1.03)	(1.02)	(1.00)	(0.98)	(0.95)	(0.88)
10.0	89.8	87.9	84.2	81.6	78.8	72.6
	(1.09)	(1.07)	(1.02)	(0.99)	(0.95)	(0.88)
15.0	93.5	89.3	84.2	81.6	78.8	72.6
	(1.13)	(1.08)	(1.02)	(0.99)	(0.95)	(0.88)

Table 11. Heating capacity for RAS-28FSXN

Capacity unit: kW (Correction factor)						
Outdoor air inlet °C (DB)	Indoor air inlet °C (WB)					
	16.0	18.0	20.0	21.0	22.0	24.0
-10.0	64.8	64.8	64.8	64.8	64.6	64.4
	(0.72)	(0.72)	(0.72)	(0.72)	(0.72)	(0.72)
-5.0	74.3	74.2	74.0	73.8	73.6	73.3
	(0.83)	(0.82)	(0.82)	(0.82)	(0.82)	(0.81)
0.0	82.3	82.1	81.9	81.5	81.0	78.6
	(0.91)	(0.91)	(0.91)	(0.91)	(0.90)	(0.87)
5.0	90.7	90.0	89.1	88.0	85.5	79.2
	(1.01)	(1.00)	(0.99)	(0.98)	(0.95)	(0.88)
6.0	94.1	92.3	90.0	88.6	85.9	79.2
	(1.05)	(1.03)	(1.00)	(0.98)	(0.95)	(0.88)
10.0	98.6	96.6	91.8	89.0	85.9	79.2
	(1.10)	(1.07)	(1.02)	(0.99)	(0.95)	(0.88)
15.0	102.0	97.5	91.8	89.0	85.9	79.2
	(1.13)	(1.08)	(1.02)	(0.99)	(0.95)	(0.88)

**Table 12. Heating capacity for RAS-30FSXN**

Capacity unit: kW (Correction factor)						
Outdoor air inlet °C (DB)	Indoor air inlet °C (WB)					
	16.0	18.0	20.0	21.0	22.0	24.0
-10.0	67.4	67.4	67.4	67.4	67.2	67.0
	(0.71)	(0.71)	(0.71)	(0.71)	(0.71)	(0.71)
-5.0	77.5	77.3	77.1	76.9	76.7	76.3
	(0.82)	(0.81)	(0.81)	(0.81)	(0.81)	(0.80)
0.0	86.4	86.2	86.1	85.7	85.1	82.7
	(0.91)	(0.91)	(0.91)	(0.90)	(0.90)	(0.87)
5.0	95.6	94.8	93.9	92.8	90.2	83.6
	(1.01)	(1.00)	(0.99)	(0.98)	(0.95)	(0.88)
6.0	99.3	97.6	95.0	93.5	90.7	83.6
	(1.04)	(1.03)	(1.00)	(0.98)	(0.95)	(0.88)
10.0	104.1	101.9	96.9	94.0	90.7	83.6
	(1.10)	(1.07)	(1.02)	(0.99)	(0.95)	(0.88)
15.0	107.7	102.9	96.9	94.0	90.7	83.6
	(1.13)	(1.08)	(1.02)	(0.99)	(0.95)	(0.88)

**Table 13. Heating capacity for RAS-32FSXN**

Capacity unit: kW (Correction factor)						
Outdoor air inlet °C (DB)	Indoor air inlet °C (WB)					
	16.0	18.0	20.0	21.0	22.0	24.0
-10.0	70.0	70.0	70.0	70.0	69.8	69.6
	(0.70)	(0.70)	(0.70)	(0.70)	(0.70)	(0.70)
-5.0	80.6	80.4	80.2	80.0	79.8	79.4
	(0.81)	(0.80)	(0.80)	(0.80)	(0.80)	(0.79)
0.0	90.6	90.4	90.2	89.8	89.2	86.8
	(0.91)	(0.90)	(0.90)	(0.90)	(0.89)	(0.87)
5.0	100.4	99.6	98.6	97.6	94.8	88.0
	(1.00)	(1.00)	(0.99)	(0.98)	(0.95)	(0.88)
6.0	104.4	102.8	100.0	98.4	95.5	88.0
	(1.04)	(1.03)	(1.00)	(0.98)	(0.95)	(0.88)
10.0	109.6	107.3	102.0	98.9	95.5	88.0
	(1.10)	(1.07)	(1.02)	(0.99)	(0.95)	(0.88)
15.0	113.3	108.3	102.0	98.9	95.5	88.0
	(1.13)	(1.08)	(1.02)	(0.99)	(0.95)	(0.88)

4

Table 14. Heating capacity for RAS-34FSXN

Capacity unit: kW (Correction factor)						
Outdoor air inlet °C (DB)	Indoor air inlet °C (WB)					
	16.0	18.0	20.0	21.0	22.0	24.0
-10.0	74.2	74.2	74.2	74.2	74.0	73.8
	(0.70)	(0.70)	(0.70)	(0.70)	(0.70)	(0.70)
-5.0	85.4	85.2	85.0	84.8	84.6	84.2
	(0.81)	(0.80)	(0.80)	(0.80)	(0.80)	(0.79)
0.0	96.0	95.8	95.6	95.2	94.6	92.0
	(0.91)	(0.90)	(0.90)	(0.90)	(0.89)	(0.87)
5.0	106.4	105.6	104.5	103.5	100.5	93.3
	(1.00)	(1.00)	(0.99)	(0.98)	(0.95)	(0.88)
6.0	110.7	109.0	106.0	104.3	101.2	93.3
	(1.04)	(1.03)	(1.00)	(0.98)	(0.95)	(0.88)
10.0	116.2	113.7	108.1	104.9	101.2	93.3
	(1.10)	(1.07)	(1.02)	(0.99)	(0.95)	(0.88)
15.0	120.1	114.8	108.1	104.9	101.2	93.3
	(1.13)	(1.08)	(1.02)	(0.99)	(0.95)	(0.88)

Table 15. Heating capacity for RAS-36FSXN

Capacity unit: kW (Correction factor)						
Outdoor air inlet °C (DB)	Indoor air inlet °C (WB)					
	16.0	18.0	20.0	21.0	22.0	24.0
-10.0	78.4	78.4	78.4	78.4	78.2	78.0
	(0.70)	(0.70)	(0.70)	(0.70)	(0.70)	(0.70)
-5.0	90.3	90.0	89.8	89.6	89.4	88.9
	(0.81)	(0.80)	(0.80)	(0.80)	(0.80)	(0.79)
0.0	101.5	101.2	101.0	100.6	99.9	97.2
	(0.91)	(0.90)	(0.90)	(0.90)	(0.89)	(0.87)
5.0	112.4	111.6	110.4	109.3	106.2	98.6
	(1.00)	(1.00)	(0.99)	(0.98)	(0.95)	(0.88)
6.0	116.9	115.1	112.0	110.2	106.9	98.6
	(1.04)	(1.03)	(1.00)	(0.98)	(0.95)	(0.88)
10.0	122.8	120.2	114.2	110.8	106.9	98.6
	(1.10)	(1.07)	(1.02)	(0.99)	(0.95)	(0.88)
15.0	126.9	121.3	114.2	110.8	106.9	98.6
	(1.13)	(1.08)	(1.02)	(0.99)	(0.95)	(0.88)



Table 16. Heating capacity for RAS-38FSXN

Capacity unit: kW (Correction factor)						
Outdoor air inlet °C (DB)	Indoor air inlet °C (WB)					
	16.0	18.0	20.0	21.0	22.0	24.0
-10.0	81.2	81.2	81.2	81.2	80.9	80.7
	(0.69)	(0.69)	(0.69)	(0.69)	(0.69)	(0.68)
-5.0	94.6	94.5	94.4	94.2	94.0	93.3
	(0.80)	(0.80)	(0.80)	(0.80)	(0.80)	(0.79)
0.0	107.1	107.0	107.0	106.6	106.1	103.0
	(0.91)	(0.91)	(0.91)	(0.90)	(0.90)	(0.87)
5.0	118.0	117.8	117.0	116.0	112.7	103.8
	(1.00)	(1.00)	(0.99)	(0.98)	(0.96)	(0.88)
6.0	121.0	119.8	118.0	116.0	112.7	103.8
	(1.03)	(1.02)	(1.00)	(0.98)	(0.96)	(0.88)
10.0	129.3	126.6	120.4	116.7	112.7	103.8
	(1.10)	(1.07)	(1.02)	(0.99)	(0.96)	(0.88)
15.0	133.7	127.8	120.4	116.7	112.7	103.8
	(1.13)	(1.08)	(1.02)	(0.99)	(0.96)	(0.88)

Table 17. Heating capacity for RAS-40FSXN

Capacity unit: kW (Correction factor)						
Outdoor air inlet °C (DB)	Indoor air inlet °C (WB)					
	16.0	18.0	20.0	21.0	22.0	24.0
-10.0	83.8	83.8	83.8	83.8	83.5	83.3
	(0.67)	(0.67)	(0.67)	(0.67)	(0.67)	(0.67)
-5.0	97.8	97.7	97.6	97.3	97.1	96.4
	(0.78)	(0.78)	(0.78)	(0.78)	(0.78)	(0.77)
0.0	111.3	111.2	111.1	110.8	110.2	107.2
	(0.89)	(0.89)	(0.89)	(0.89)	(0.88)	(0.86)
5.0	124.0	123.6	122.5	121.3	118.4	110.0
	(0.99)	(0.99)	(0.98)	(0.97)	(0.95)	(0.88)
6.0	128.3	127.5	125.0	123.0	119.3	110.0
	(1.03)	(1.02)	(1.00)	(0.98)	(0.95)	(0.88)
10.0	135.8	132.9	127.5	123.7	119.3	110.0
	(1.09)	(1.06)	(1.02)	(0.99)	(0.95)	(0.88)
15.0	141.7	135.4	127.5	123.7	119.3	110.0
	(1.13)	(1.08)	(1.02)	(0.99)	(0.95)	(0.88)

Table 18. Heating capacity for RAS-42FSXN

Capacity unit: kW (Correction factor)						
Outdoor air inlet °C (DB)	Indoor air inlet °C (WB)					
	16.0	18.0	20.0	21.0	22.0	24.0
-10.0	88.0	88.0	88.0	88.0	87.7	87.4
	(0.67)	(0.67)	(0.67)	(0.67)	(0.66)	(0.66)
-5.0	102.6	102.5	102.4	102.1	101.8	101.2
	(0.78)	(0.78)	(0.78)	(0.77)	(0.77)	(0.77)
0.0	116.7	116.6	116.5	116.1	115.5	112.4
	(0.88)	(0.88)	(0.88)	(0.88)	(0.88)	(0.85)
5.0	130.0	129.6	128.4	127.1	124.0	115.3
	(0.99)	(0.98)	(0.97)	(0.96)	(0.94)	(0.87)
6.0	134.6	133.7	132.0	129.6	125.1	115.3
	(1.02)	(1.01)	(1.00)	(0.98)	(0.95)	(0.87)
10.0	142.4	139.3	133.6	129.6	125.1	115.3
	(1.08)	(1.06)	(1.01)	(0.98)	(0.95)	(0.87)
15.0	148.5	141.9	133.6	129.6	125.1	115.3
	(1.12)	(1.07)	(1.01)	(0.98)	(0.95)	(0.87)

Table 19. Heating capacity for RAS-44FSXN

Capacity unit: kW (Correction factor)						
Outdoor air inlet °C (DB)	Indoor air inlet °C (WB)					
	16.0	18.0	20.0	21.0	22.0	24.0
-10.0	96.0	96.0	96.0	96.0	95.7	95.4
	(0.69)	(0.69)	(0.69)	(0.69)	(0.68)	(0.68)
-5.0	111.0	110.8	110.6	110.4	110.1	109.4
	(0.79)	(0.79)	(0.79)	(0.79)	(0.79)	(0.78)
0.0	124.9	124.7	124.5	124.0	123.2	119.8
	(0.89)	(0.89)	(0.89)	(0.89)	(0.88)	(0.86)
5.0	138.5	137.7	136.4	134.9	131.3	121.9
	(0.99)	(0.98)	(0.97)	(0.96)	(0.94)	(0.87)
6.0	143.6	142.4	140.0	137.0	132.2	121.9
	(1.03)	(1.02)	(1.00)	(0.98)	(0.94)	(0.87)
10.0	151.2	148.0	141.3	137.0	132.2	121.9
	(1.08)	(1.06)	(1.01)	(0.98)	(0.94)	(0.87)
15.0	157.0	150.0	141.3	137.0	132.2	121.9
	(1.12)	(1.07)	(1.01)	(0.98)	(0.94)	(0.87)

Table 20. Heating capacity for RAS-46FSXN

Capacity unit: kW (Correction factor)						
Outdoor air inlet °C (DB)	Indoor air inlet °C (WB)					
	16.0	18.0	20.0	21.0	22.0	24.0
-10.0	98.6	98.6	98.6	98.6	98.3	98.0
	(0.68)	(0.68)	(0.68)	(0.68)	(0.68)	(0.68)
-5.0	114.2	113.9	113.7	113.5	113.2	112.5
	(0.79)	(0.79)	(0.78)	(0.78)	(0.78)	(0.78)
0.0	129.0	128.8	128.6	128.1	127.3	123.9
	(0.89)	(0.89)	(0.89)	(0.88)	(0.88)	(0.85)
5.0	143.3	142.5	141.1	139.7	136.0	126.3
	(0.99)	(0.98)	(0.97)	(0.96)	(0.94)	(0.87)
6.0	148.7	147.0	145.0	142.0	137.0	126.3
	(1.03)	(1.01)	(1.00)	(0.98)	(0.94)	(0.87)
10.0	156.7	153.3	146.4	142.0	137.0	126.3
	(1.08)	(1.06)	(1.01)	(0.98)	(0.94)	(0.87)
15.0	162.6	155.4	146.4	142.0	137.0	126.3
	(1.12)	(1.07)	(1.01)	(0.98)	(0.94)	(0.87)

Table 21. Heating capacity for RAS-48FSXN

Capacity unit: kW (Correction factor)						
Outdoor air inlet °C (DB)	Indoor air inlet °C (WB)					
	16.0	18.0	20.0	21.0	22.0	24.0
-10.0	102.8	102.8	102.8	102.8	102.5	102.2
	(0.69)	(0.69)	(0.69)	(0.69)	(0.68)	(0.68)
-5.0	119.0	118.8	118.5	118.3	118.0	117.3
	(0.79)	(0.79)	(0.79)	(0.79)	(0.79)	(0.78)
0.0	134.5	134.2	134.0	133.5	132.7	129.1
	(0.90)	(0.89)	(0.89)	(0.89)	(0.88)	(0.86)
5.0	149.3	148.5	147.0	145.5	141.7	131.6
	(1.00)	(0.99)	(0.98)	(0.97)	(0.94)	(0.88)
6.0	155.0	153.2	150.0	147.1	142.7	131.6
	(1.03)	(1.02)	(1.00)	(0.98)	(0.95)	(0.88)
10.0	163.3	159.8	152.5	147.9	142.7	131.6
	(1.09)	(1.07)	(1.02)	(0.99)	(0.95)	(0.88)
15.0	169.4	161.9	152.5	147.9	142.7	131.6
	(1.13)	(1.08)	(1.02)	(0.99)	(0.95)	(0.88)

Table 22. Heating capacity for RAS-50FSXN

Capacity unit: kW (Correction factor)						
Outdoor air inlet °C (DB)	Indoor air inlet °C (WB)					
	16.0	18.0	20.0	21.0	22.0	24.0
-10.0	110.8	110.8	110.8	110.8	110.5	110.2
	(0.71)	(0.71)	(0.71)	(0.71)	(0.71)	(0.71)
-5.0	127.4	127.1	126.8	126.5	126.2	125.6
	(0.82)	(0.82)	(0.82)	(0.82)	(0.81)	(0.81)
0.0	142.6	142.3	142.0	141.3	140.4	136.4
	(0.92)	(0.92)	(0.92)	(0.91)	(0.91)	(0.88)
5.0	157.8	156.6	155.0	152.2	148.0	136.4
	(1.02)	(1.01)	(1.00)	(0.98)	(0.95)	(0.88)
6.0	162.4	159.2	155.0	152.2	148.0	136.4
	(1.05)	(1.03)	(1.00)	(0.98)	(0.95)	(0.88)
10.0	172.0	166.4	158.1	153.3	148.0	136.4
	(1.11)	(1.07)	(1.02)	(0.99)	(0.95)	(0.88)
15.0	176.0	167.9	158.1	153.3	148.0	136.4
	(1.14)	(1.08)	(1.02)	(0.99)	(0.95)	(0.88)

Table 23. Heating capacity for RAS-52FSXN

Capacity unit: kW (Correction factor)						
Outdoor air inlet °C (DB)	Indoor air inlet °C (WB)					
	16.0	18.0	20.0	21.0	22.0	24.0
-10.0	113.4	113.4	113.4	113.4	113.1	112.8
	(0.71)	(0.71)	(0.71)	(0.71)	(0.71)	(0.70)
-5.0	130.6	130.2	129.9	129.6	129.3	128.6
	(0.82)	(0.81)	(0.81)	(0.81)	(0.81)	(0.80)
0.0	146.8	146.4	146.1	145.5	144.5	140.6
	(0.92)	(0.92)	(0.91)	(0.91)	(0.90)	(0.88)
5.0	162.6	161.4	159.7	157.6	152.8	140.8
	(1.02)	(1.01)	(1.00)	(0.99)	(0.96)	(0.88)
6.0	169.1	165.5	160.0	157.6	152.8	140.8
	(1.06)	(1.03)	(1.00)	(0.99)	(0.96)	(0.88)
10.0	177.5	171.7	163.2	158.2	152.8	140.8
	(1.11)	(1.07)	(1.02)	(0.99)	(0.96)	(0.88)
15.0	181.6	173.2	163.2	158.2	152.8	140.8
	(1.14)	(1.08)	(1.02)	(0.99)	(0.96)	(0.88)

Table 24. Heating capacity for RAS-54FSXN

Capacity unit: kW (Correction factor)						
Outdoor air inlet °C (DB)	Indoor air inlet °C (WB)					
	16.0	18.0	20.0	21.0	22.0	24.0
-10.0	117.6	117.6	117.6	117.6	117.3	116.9
	(0.71)	(0.71)	(0.71)	(0.71)	(0.71)	(0.71)
-5.0	135.4	135.1	134.7	134.4	134.1	133.4
	(0.82)	(0.82)	(0.82)	(0.81)	(0.81)	(0.81)
0.0	152.2	151.9	151.5	150.9	149.9	145.2
	(0.92)	(0.92)	(0.92)	(0.91)	(0.91)	(0.88)
5.0	168.7	167.3	164.6	162.1	157.6	145.2
	(1.02)	(1.01)	(1.00)	(0.98)	(0.96)	(0.88)
6.0	175.0	170.7	165.0	162.1	157.6	145.2
	(1.06)	(1.03)	(1.00)	(0.98)	(0.96)	(0.88)
10.0	183.0	177.0	168.3	163.1	157.6	145.2
	(1.11)	(1.07)	(1.02)	(0.99)	(0.96)	(0.88)
15.0	187.2	178.6	168.3	163.1	157.6	145.2
	(1.13)	(1.08)	(1.02)	(0.99)	(0.96)	(0.88)

## 4.8 Correction factor depending on the pipe length

### Cooling capacity correction factor depending on the pipe length

The cooling capacity must be corrected according to the following formula:

$$CCA = CC \times F$$

CCA: Current corrected cooling capacity

CC: Cooling capacity (value obtained in chapter [Tables for 100% combination cooling capacity](#), see on page 136.

F: correction factor depending on the equivalent pipe length.

The correction factors are shown in the following figure:

Equivalent pipe length for:

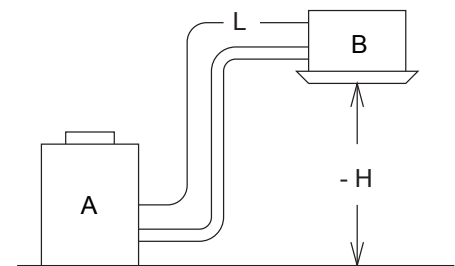
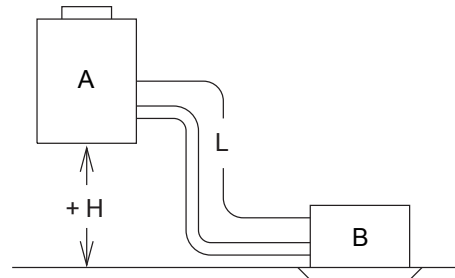
- 90° L-bend: 0.5 m.
- 180° curve: 1.5 m.
- One multikit: 0.5 m.

H: vertical distance between indoor unit and outdoor unit, in metres.

EL: total equivalent distance between the indoor unit and outdoor unit, in metres (equivalent to the length of a single pipe).

H > 0: position of the outdoor unit higher than the indoor unit.

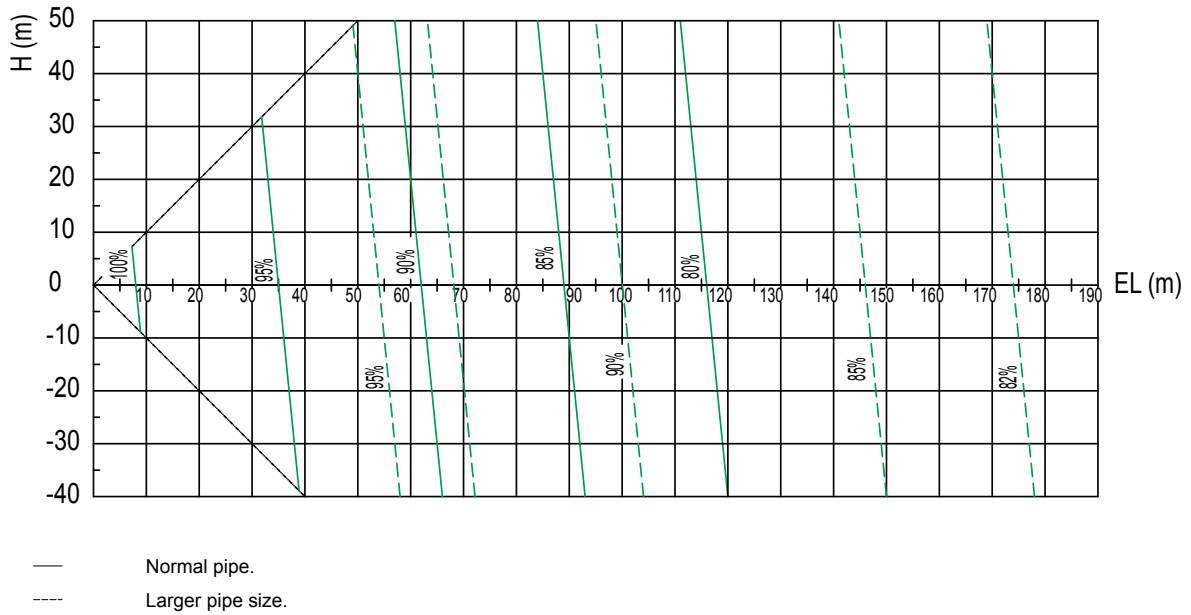
L: current length of a single pipe between the indoor unit and the outdoor unit, in metres.



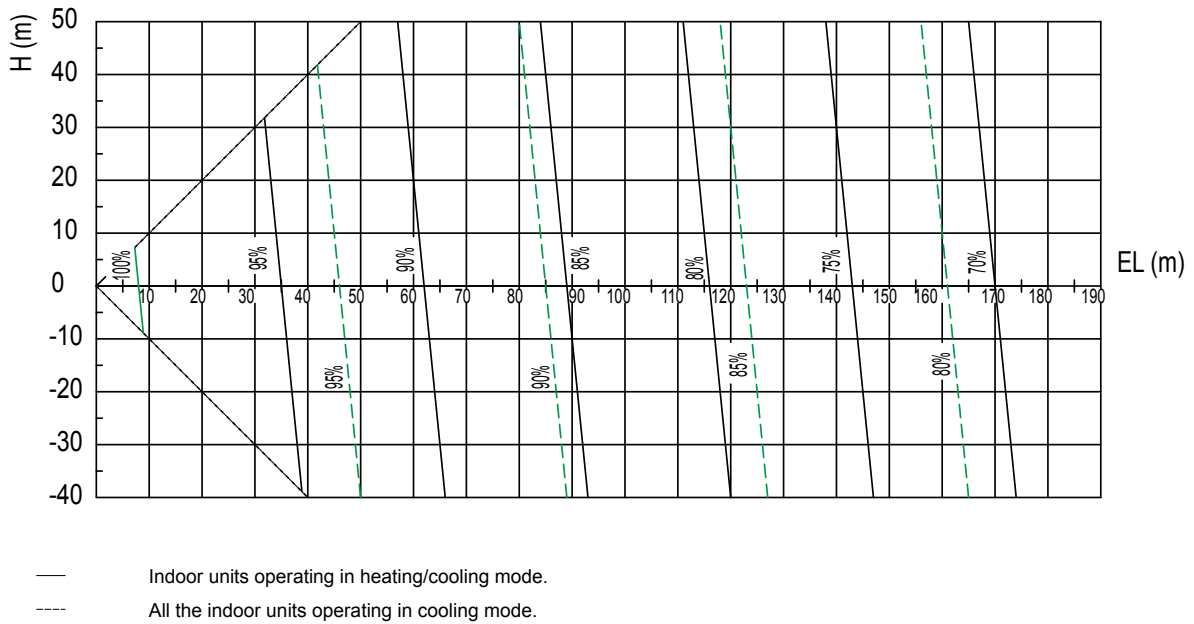
#### NOTE

- 1 **If the distance EL is greater than 100 m in heat pump systems (2 pipes), increase the gas and liquid refrigerant pipes by one size.**
- 2 **If the distance EL is greater than 100 m in heat recovery systems (3 pipes), increase the liquid pipes by one size.**
- 3 **In heat recovery systems (3 pipes), the dotted line for the cooling capacity correction factor indicates that all the indoor units function in cooling mode. Even if one of the indoor units functions in heating mode, the value shall be indicated by the continuous line.**

**Heat pump system (2 pipes). Cooling**



**Heat recovery system (3 pipes). Cooling**



**Heating capacity correction factor depending on the pipe length**

The heating capacity must be corrected according to the following formula:

$$HCA = HC \times F$$

HCA: Current corrected heating capacity

CC: Heating capacity (value obtained in chapter [Tables for 100% combination heating capacity](#), see on page 145.

F: correction factor depending on the equivalent pipe length.

The correction factors are shown in the following figure:

Equivalent pipe length for:

- 90° L-bend: 0.5 m.
- 180° curve: 1.5 m.
- One multikit: 0.5 m.

H: vertical distance between indoor unit and outdoor unit, in metres.

EL: total equivalent distance between the indoor unit and outdoor unit, in metres (equivalent to the length of a single pipe).

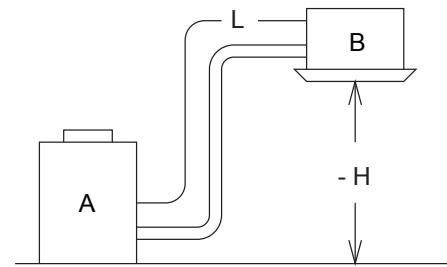
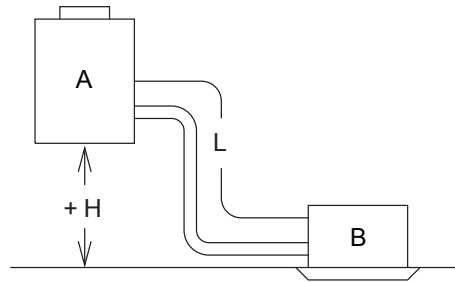
H > 0: position of the outdoor unit higher than the indoor unit.

L: current length of a single pipe between the indoor unit and the outdoor unit, in metres.



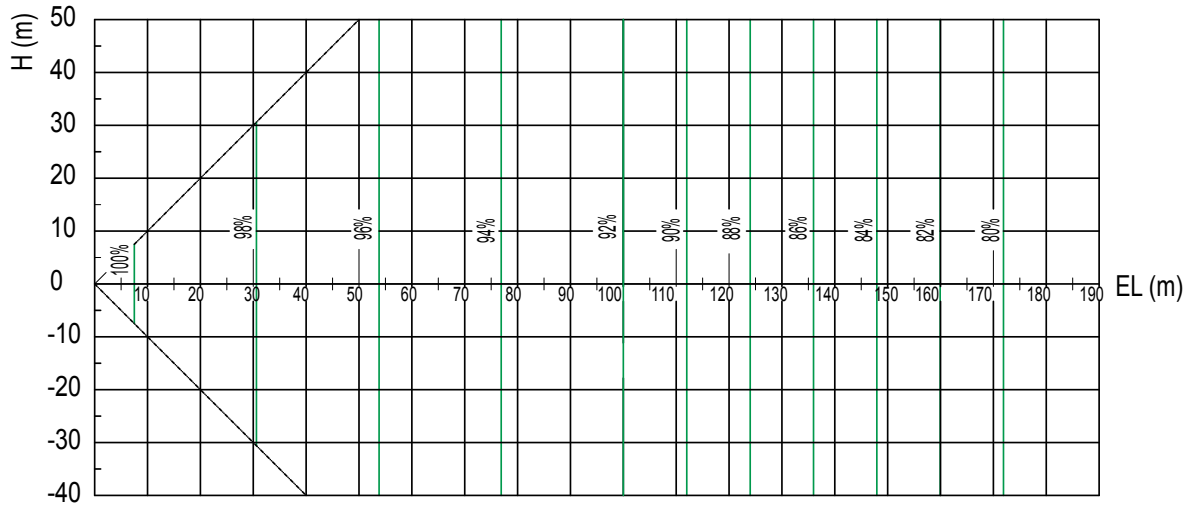
**NOTE**

- 1 **If the distance EL is greater than 100 m in heat pump systems (2 pipes), increase the gas and liquid refrigerant pipes by one size.**
- 2 **If the distance EL is greater than 100 m in heat recovery systems (3 pipes), increase the liquid pipes by one size.**

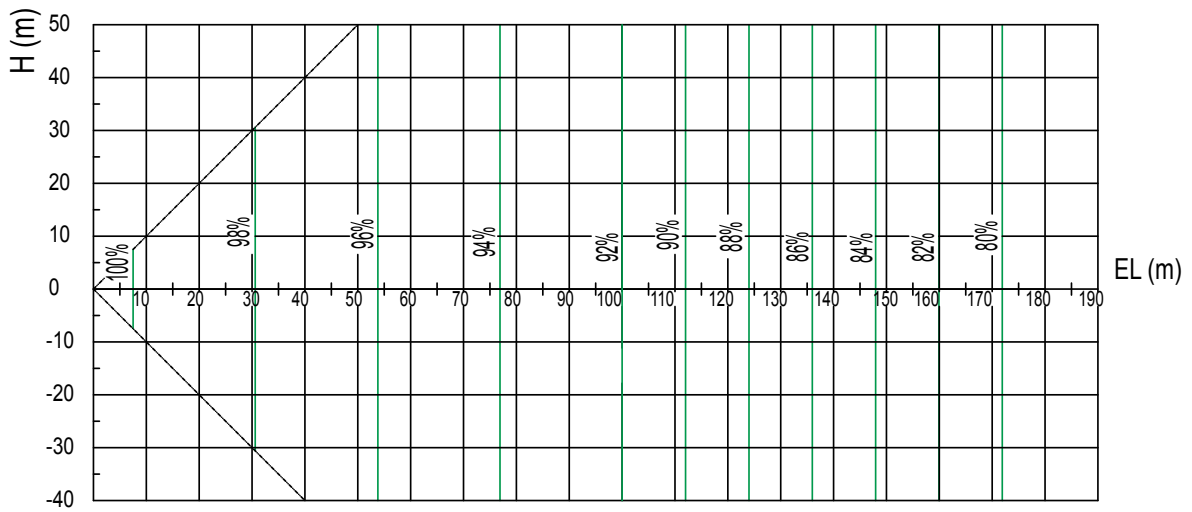




**Heat pump system (2 pipes). Cooling**



**Heat recovery system (3 pipes). Cooling**



4

## 4.9 Correction factor depending on defrost

The heating capacity described in the preceding section excludes running in periods of frost or defrost operation. In reference to running in frost or defrost operation, the heating capacity is corrected with the following equation:

$$\text{Corrected heating capacity} = (\text{correction factor}) \times (\text{heating capacity})$$

Inlet air temperature in the outdoor heat exchanger (°C DB)	-7	-5	-3	0	3	5	7
Correction factor	0.95	0.93	0.88	0.85	0.87	0.90	1.0



### NOTE

- **DB: dry bulb; WB: wet bulb.**
- **The correction factor depending on defrost is not applicable in special conditions, such as snowfall or operation during transient periods.**

## 4.10 Sensible heat factor (SHF)

Sensible heat factor of the indoor units for each fan speed (high, medium, slow), according to the JIS B8616 Standard.

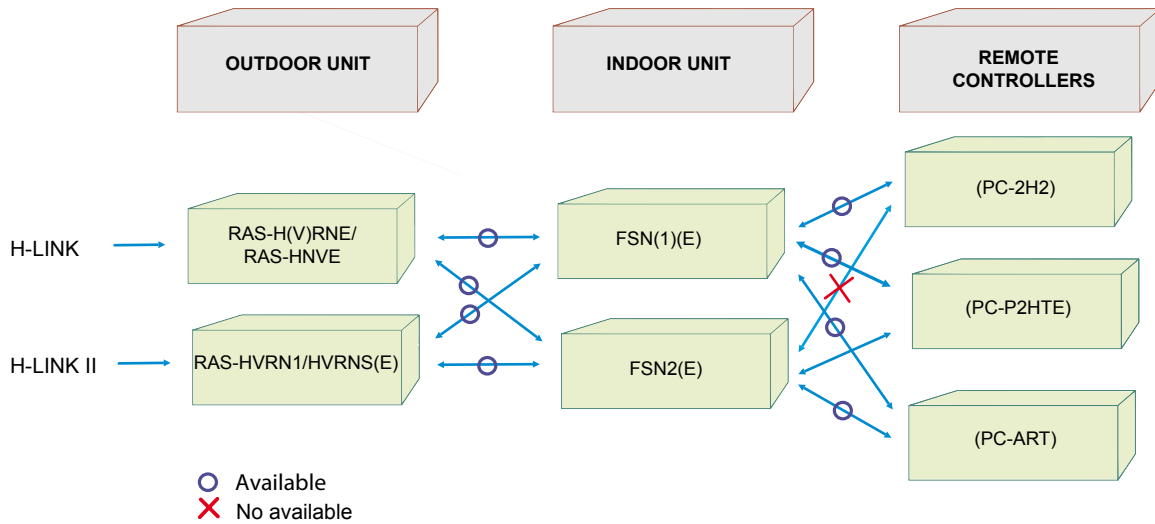
Indoor unit model	Sensible heat factor (SHF)		
	High	Medium	Low
RCI-1.0FSN2E	0.80	0.77	0.75
RCI-1.5FSN2E	0.77	0.75	0.73
RCI-2.0FSN2E	0.78	0.76	0.75
RCI-2.5FSN2E	0.73	0.71	0.69
RCI-3.0FSN2E	0.79	0.76	0.72
RCI-4.0FSN2E	0.78	0.75	0.72
RCI-5.0FSN2E	0.74	0.70	0.68
RCI-6.0FSN2E	0.73	0.69	0.68
RCIM-1.0FSN2	0.74	0.71	0.70
RCIM-1.5FSN2	0.74	0.71	0.70
RCIM-2.0FSN2	0.71	0.68	0.67
RCD-1.0FSN2	0.81	0.76	0.75
RCD-1.5FSN2	0.73	0.69	0.66
RCD-2.0FSN2	0.75	0.67	0.65
RCD-2.5FSN2	0.74	0.67	0.65
RCD-3.0FSN2	0.74	0.67	0.65
RCD-4.0FSN2	0.73	0.67	0.65
RCD-5.0FSN2	0.69	0.67	0.65
RPC-2.0FSN2E	0.72	0.70	0.67
RPC-2.5FSN2E	0.72	0.70	0.67
RPC-3.0FSN2E	0.72	0.70	0.67
RPC-4.0FSN2E	0.72	0.70	0.67
RPC-5.0FSN2E	0.72	0.70	0.67
RPC-6.0FSN2E	0.72	0.70	0.67
RPI-0.8FSN2E	0.81	0.69	0.69
RPI-1.0FSN2E	0.81	0.69	0.69
RPI-1.5FSN2E	0.73	0.69	0.65
RPI-2.0FSN2E	0.76	0.75	0.74
RPI-2.5FSN2E	0.76	0.74	0.72
RPI-3.0FSN2E	0.75	0.71	0.67
RPI-4.0FSN2E	0.73	0.71	0.65
RPI-5.0FSN2E	0.72	0.68	0.64
RPI-6.0FSN2E	0.72	0.69	0.67
RPI-8.0FSN2E	0.77	0.77	0.70
RPI-10.0FSN2E	0.79	0.79	0.72
RPIM-0.8FSN2E (-DU)	0.81	0.69	0.69
RPIM-1.0FSN2E(-DU)	0.81	0.69	0.69
RPIM-1.5FSN2E(-DU)	0.71	0.68	0.64
RPK-1.0FSN(H)2M	0.73	0.72	0.70
RPK-1.5FSN(H)2M	0.73	0.72	0.70
RPK-2.0FSN2M	0.72	0.71	0.68
RPK-2.5FSN2M	0.75	0.74	0.71

Indoor unit model	Sensible heat factor (SHF)		
	High	Medium	Low
RPK-3.0FSN2M	0.74	0.73	0.70
RPK-4.0FSN2M	0.71	0.70	0.67
RPF(I)-1.0FSN2E	0.73	0.69	0.65
RPF(I)-1.5FSN2E	0.73	0.69	0.65
RPF(I)-2.0FSN2E	0.73	0.69	0.65
RPF(I)-2.5FSN2E	0.73	0.69	0.65

## 4.11 Compatibility

H-LINK and H-LINK II communication networks are combined with their remote controls in line with the following examples.

- The new H-LINK II communication network system provides for remote control connection, from the PC-P2HTE model.
- HITACHI has a range of individual, centralised or computer-aided remote control systems that can be used with the SYSTEM FREE indoor units and the SET FREE FSNX outdoor units. Please consult the corresponding Technical Catalogue for controls.

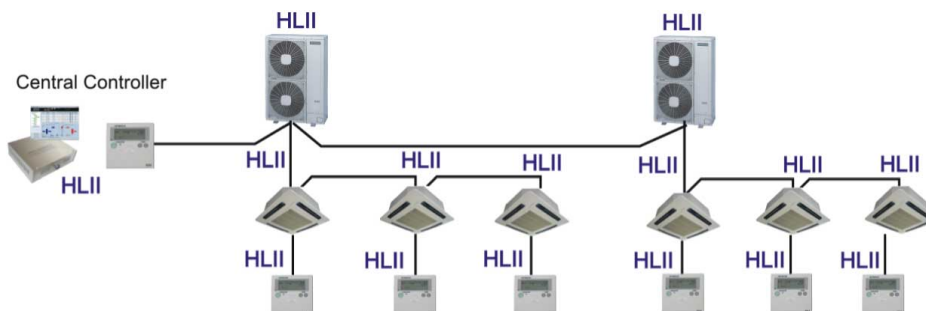


### **i** NOTE

- *The RCI-FSN2E indoor unit can be connected to the P-G23WA2 panel (cutting bridge J4).*
- *(\*) In both combinations, some of the functions of the indoor unit cannot be used.*

#### 4.11.1 Examples of different H-LINK and H-LINK II systems

**Example 1. System with outdoor and indoor units, remote control and H-LINK II communication network**



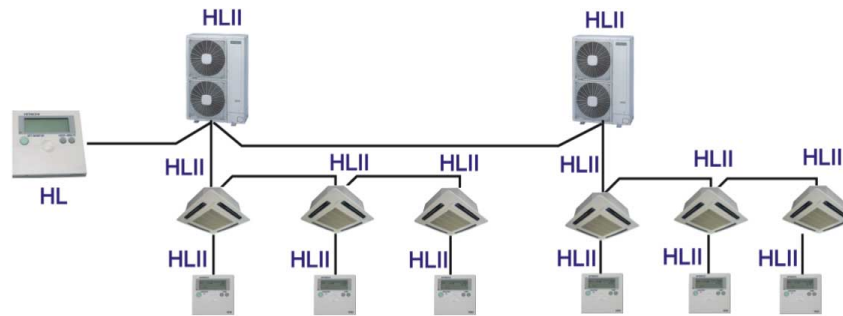
### **i** NOTE

**HLII: bus line.**

Refrigerant cycle number range	0-63
Indoor unit number range	0-63
Maximum number of indoor units	160
Maximum number of units (*)	200

(\*) Units = indoor units + outdoor units + centralised control.

**Example 2. System with outdoor and indoor units, H-LINK II remote control and H-LINK central control**



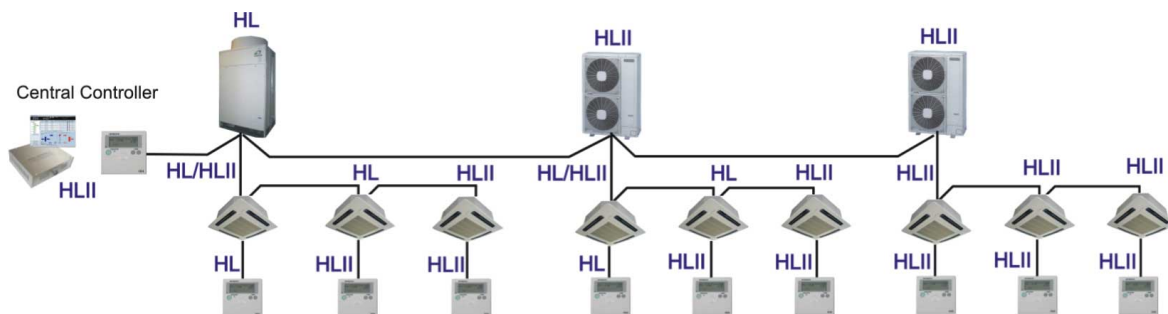
**NOTE**

- **HL: H-LINK.**
- **HLII: bus line.**

Refrigerant cycle number range	0-15
Indoor unit number range	0-15
Maximum number of indoor units	128
Maximum number of units (*)	145

(\*) Units = indoor units + outdoor units + centralised control.

**Example 3. System with outdoor and indoor units, H-LINK remote controls and H-LINK II central control**



Combination of units	1	2	3
Refrigerant cycle number range	0-15	0-15	0-63
Indoor unit number range	0-15	0-15	0-63
Maximum number of indoor units	128		
Maximum number of units (*)	145		

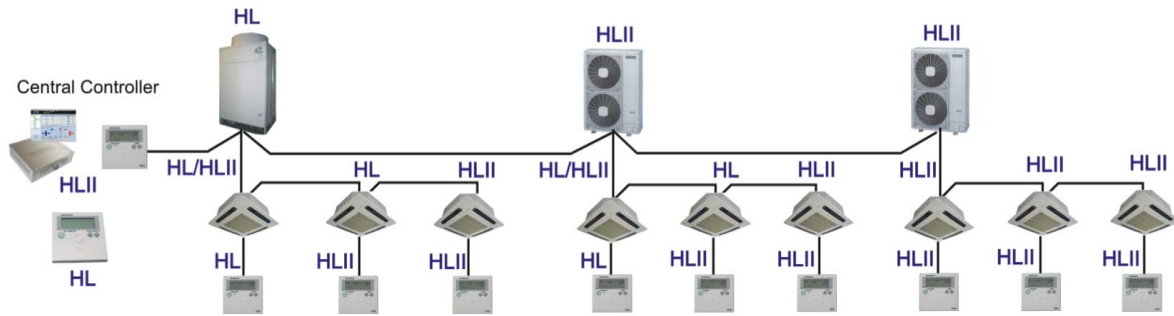
(\*) Units = indoor units + outdoor units + centralised control.



**NOTE**

- **HL: H-LINK**
- **HLII: H-LINK II**

**Example 4. System with outdoor and indoor units, H-LINK and H-LINK II remote controls and H-LINK central control**



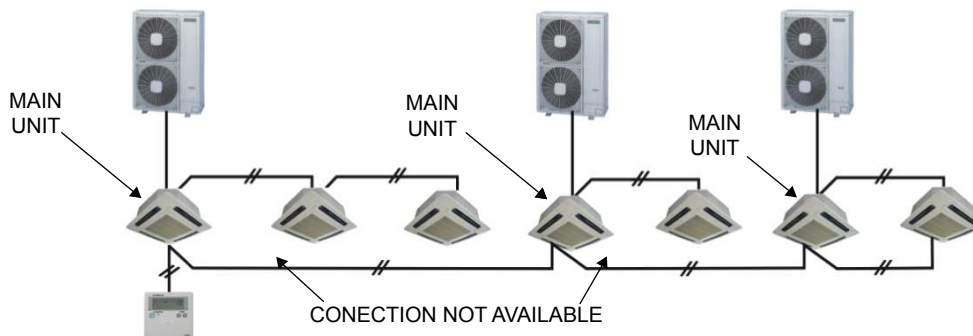
**NOTE**

- **HL: H-LINK**
- **HLII: H-LINK II**

Refrigerant cycle number range	0-15
Indoor unit number range	0-15
Maximum number of indoor units	128
Maximum number of units (*)	145

(\*) Units = indoor units + outdoor units + centralised control.

**The following connections are not possible:**



Different indoor units from different systems cannot be connected using the same remote control when the option to not use the remote control operating cable has been selected.

All optional units connected to CN3 may only be used on the main unit using the connected remote control.





# 5. Acoustic characteristic curves

## Index

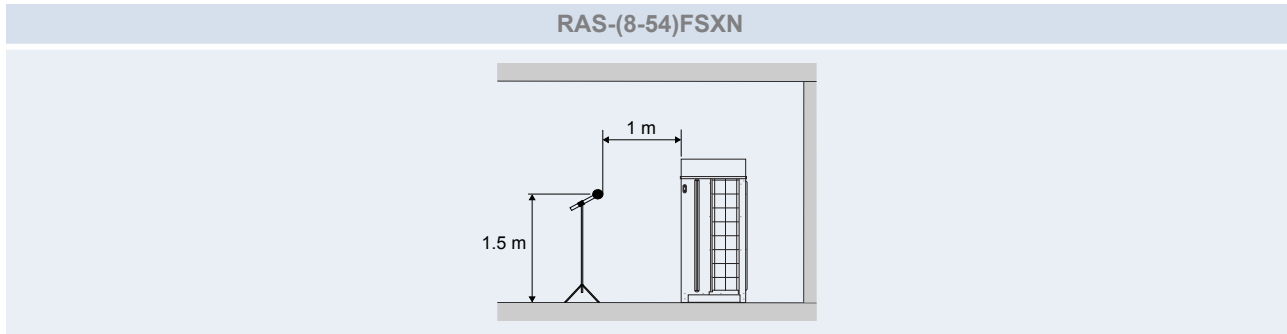
5.1	Overall sound level.....	170
5.2	Outdoor units RAS-(8-54)FSXN.....	171

## 5.1 Overall sound level

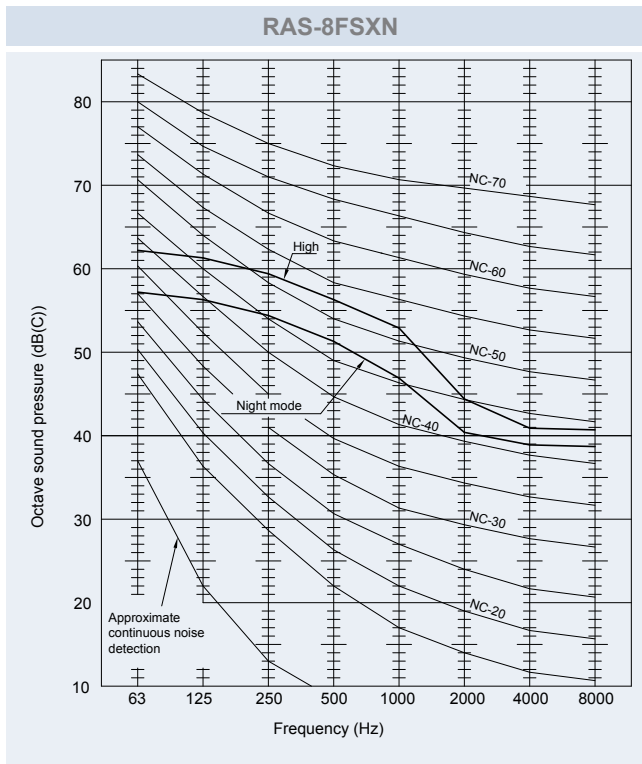
---

- 1 The overall sound level has been measured under the following conditions:
  - a 1 m from the surface of the unit's service cover.
  - b 1.5 m from floor level.
- 2 The data indicated is based on cooling mode. In the case of heating mode, the sound pressure level increases from 1 to 2 dB.
- 3 The data indicated has been measured in an anechoic chamber, so the reflected sound must be taken into account for installation.

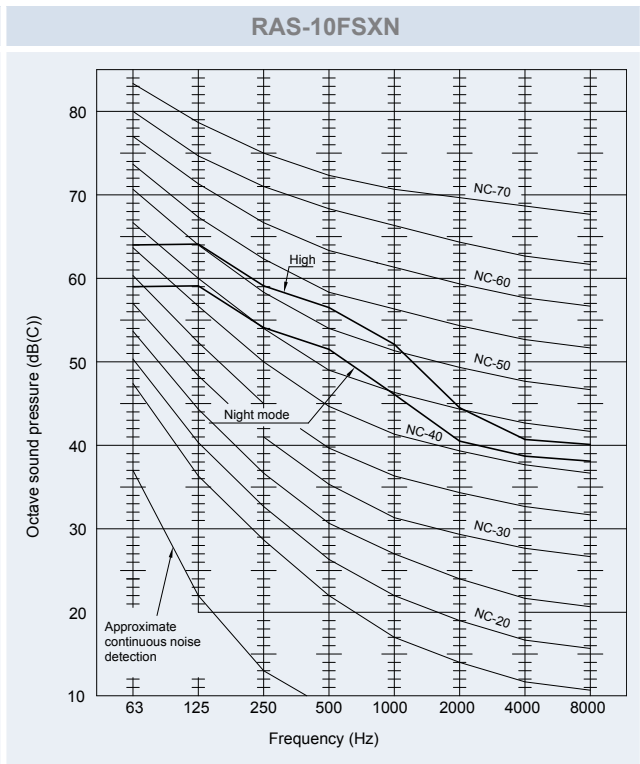
### Overall sound level measuring positions



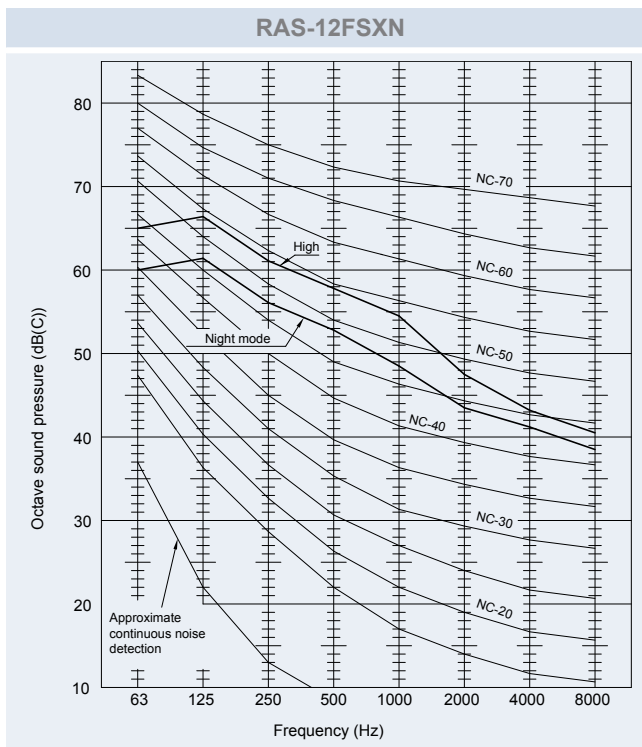
**5.2 Outdoor units RAS-(8-54)FSXN**



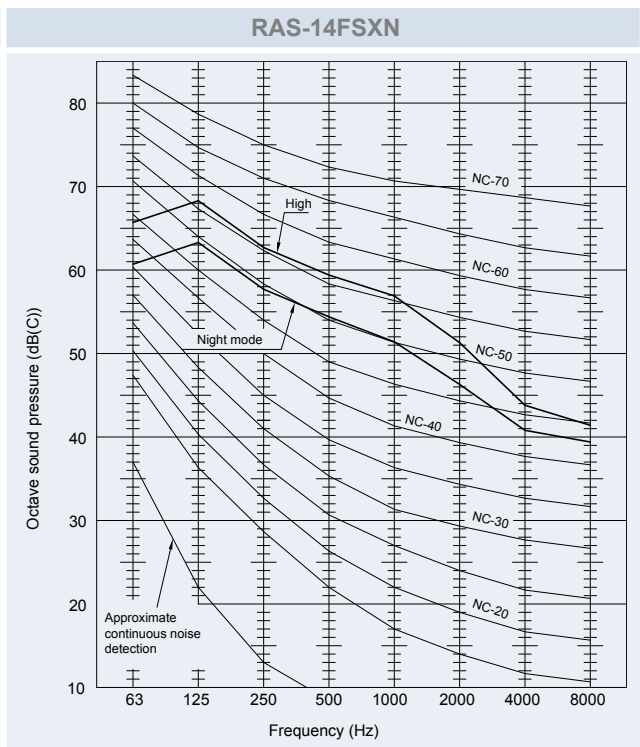
Sound pressure level: Global (night mode); 58 (53)



Sound pressure level: Global (night mode); 58 (53)

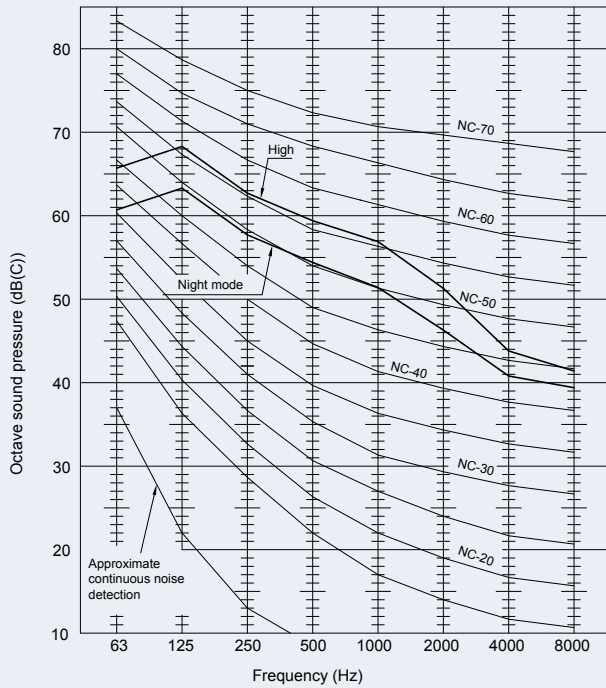


Sound pressure level: Global (night mode); 60 (55)



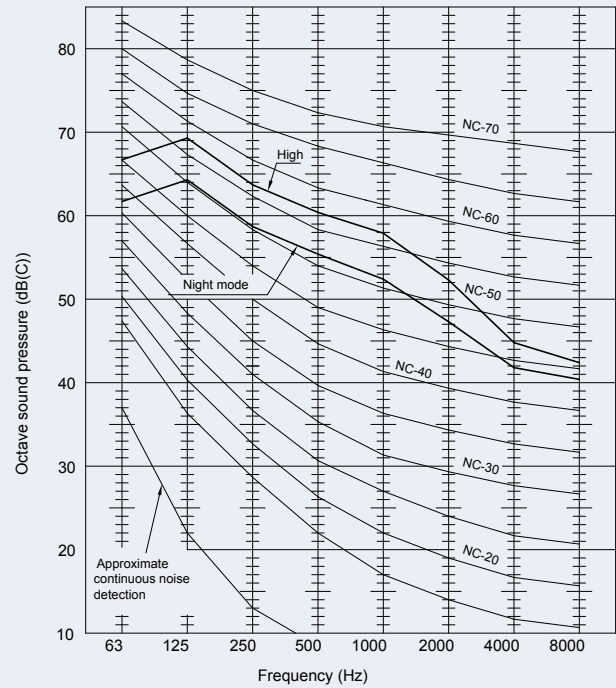
Sound pressure level: Global (night mode); 62 (57)

**RAS-16FSXN**



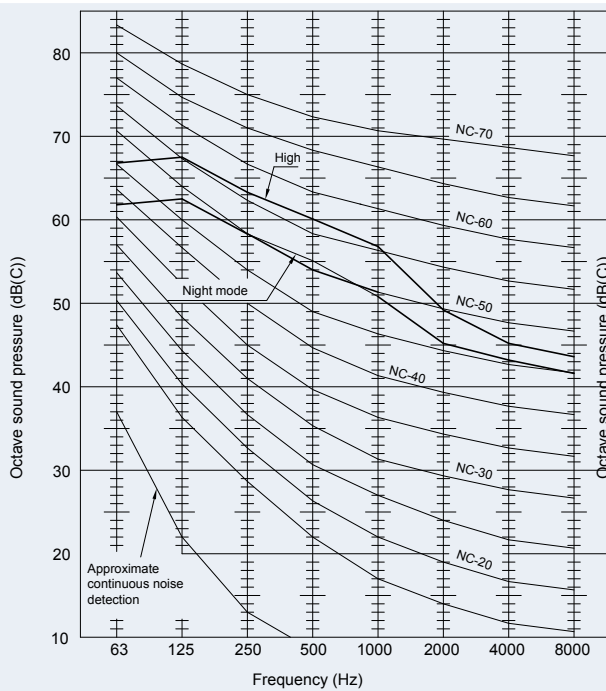
Sound pressure level: Global (night mode); 62 (57)

**RAS-18FSXN**



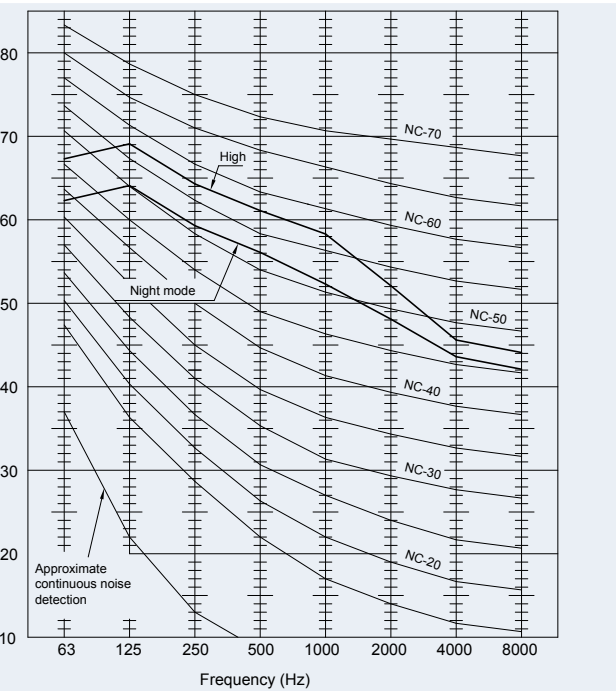
Sound pressure level: Global (night mode); 63 (58)

**RAS-20FSXN**

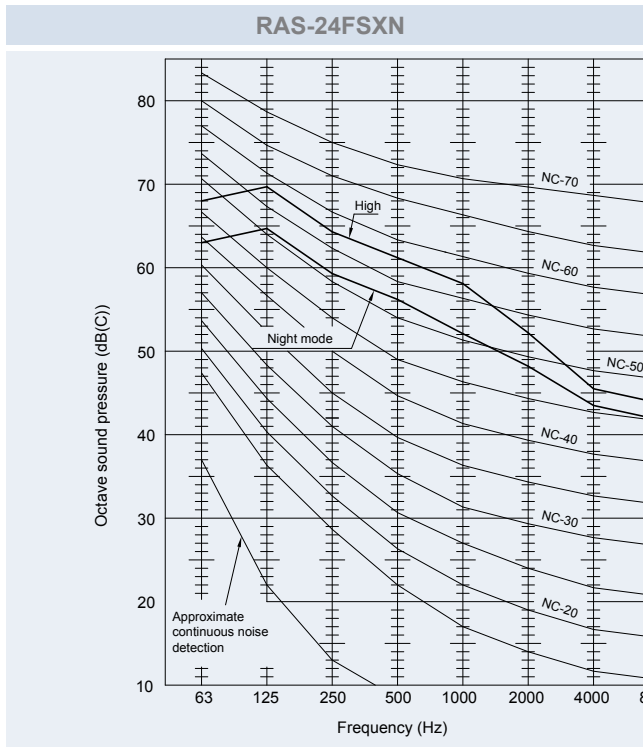


Sound pressure level: Global (night mode); 62 (57)

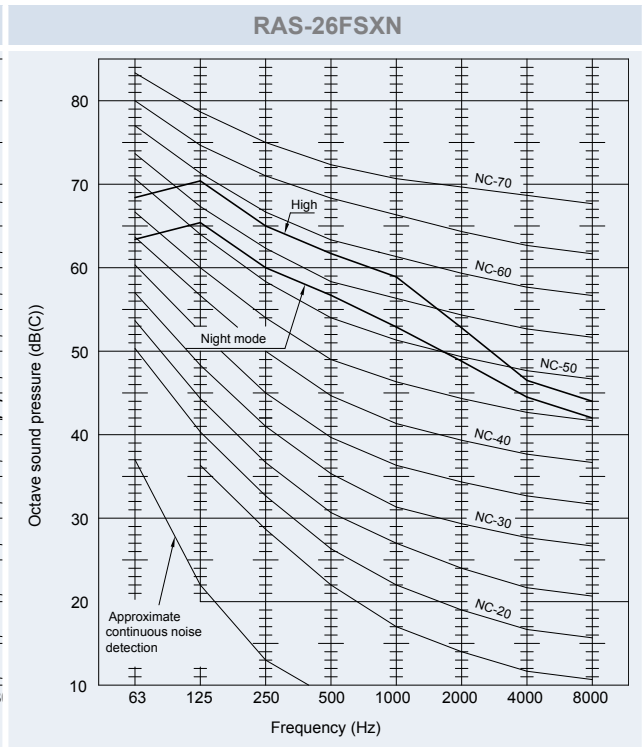
**RAS-22FSXN**



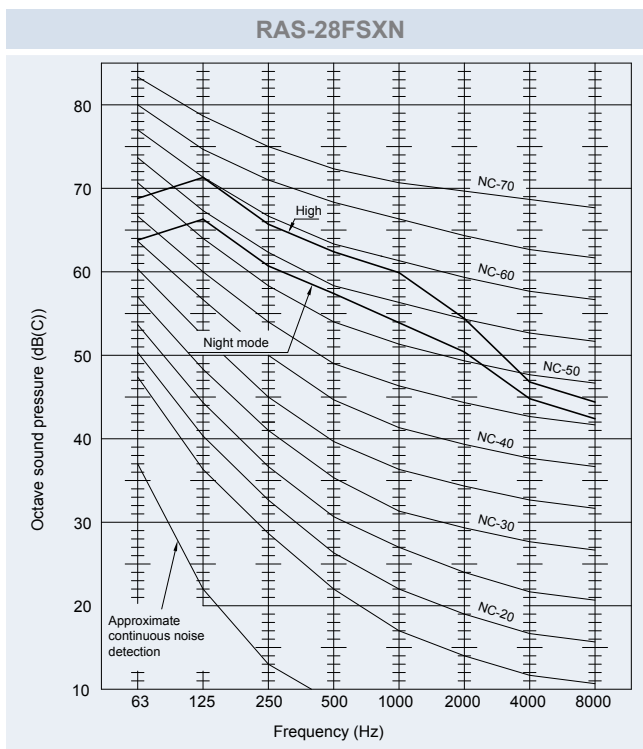
Sound pressure level: Global (night mode); 63 (58)



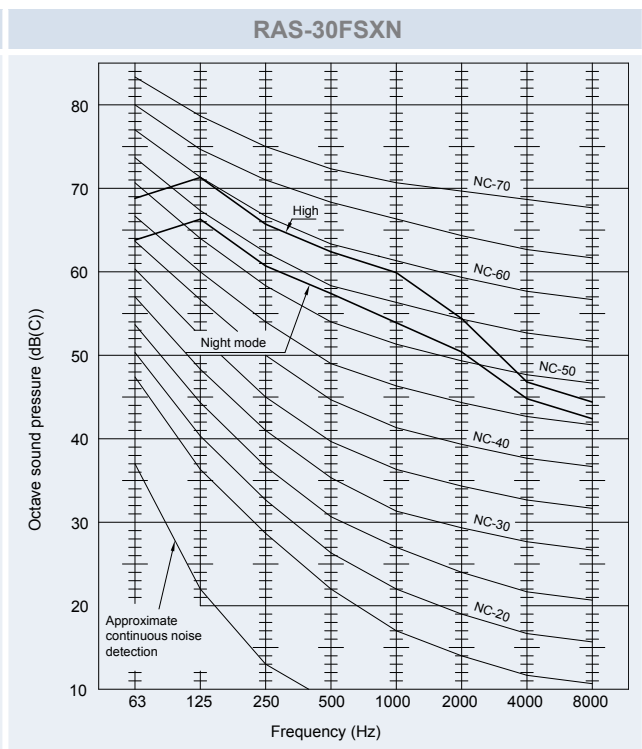
Sound pressure level: Global (night mode); 63 (58)



Sound pressure level: Global (night mode); 64 (59)



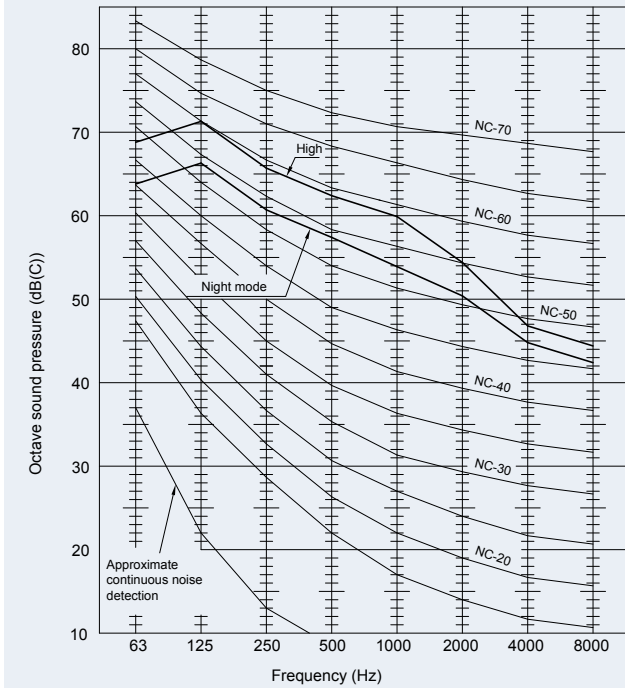
Sound pressure level: Global (night mode); 65 (60)



Sound pressure level: Global (night mode); 65 (60)

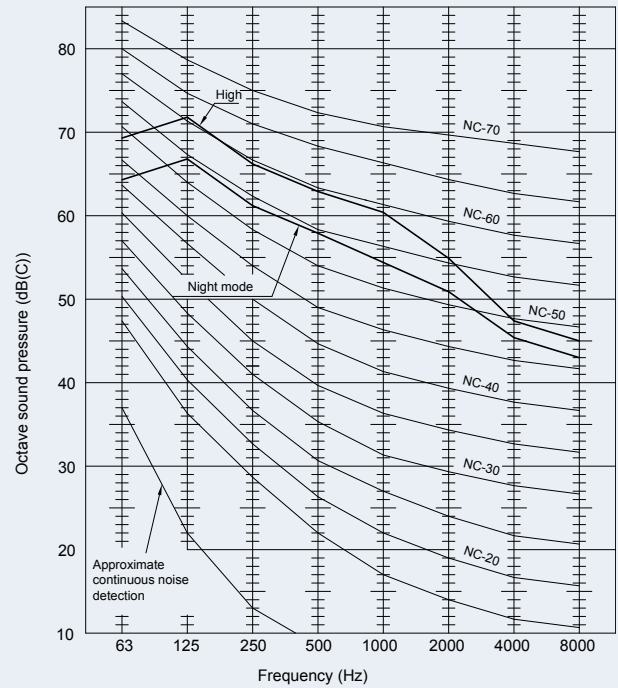
5

**RAS-32FSXN**



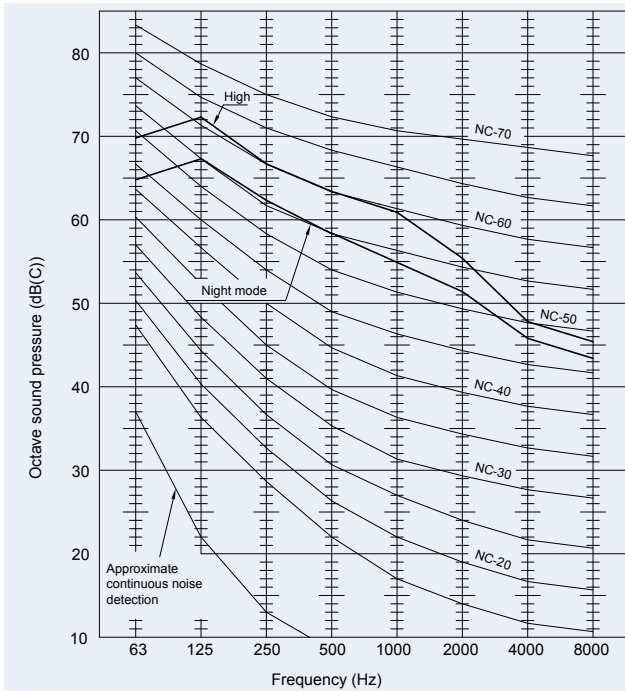
Sound pressure level: Global (night mode); 65 (60)

**RAS-34FSXN**



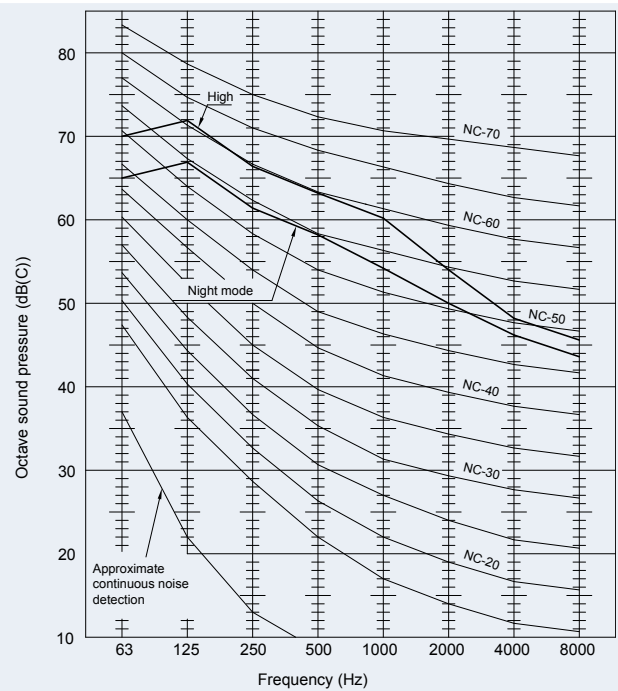
Sound pressure level: Global (night mode); 66 (61)

**RAS-36FSXN**



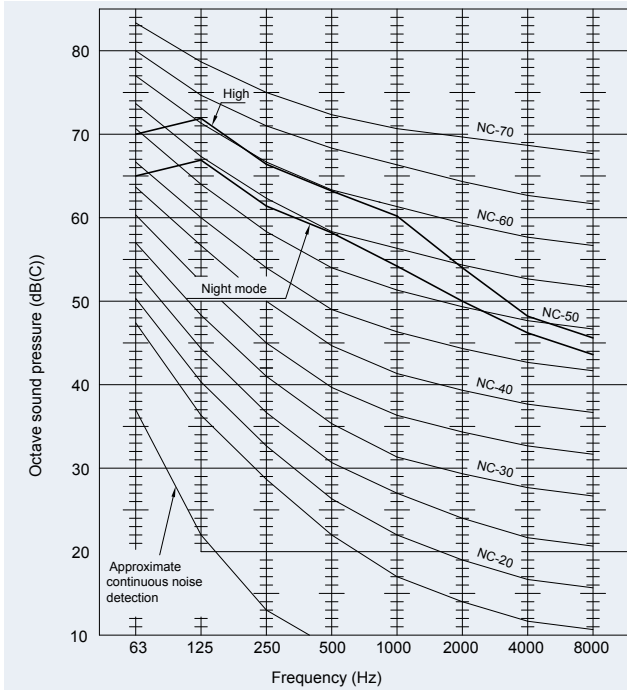
Sound pressure level: Global (night mode); 66 (61)

**RAS-38FSXN**



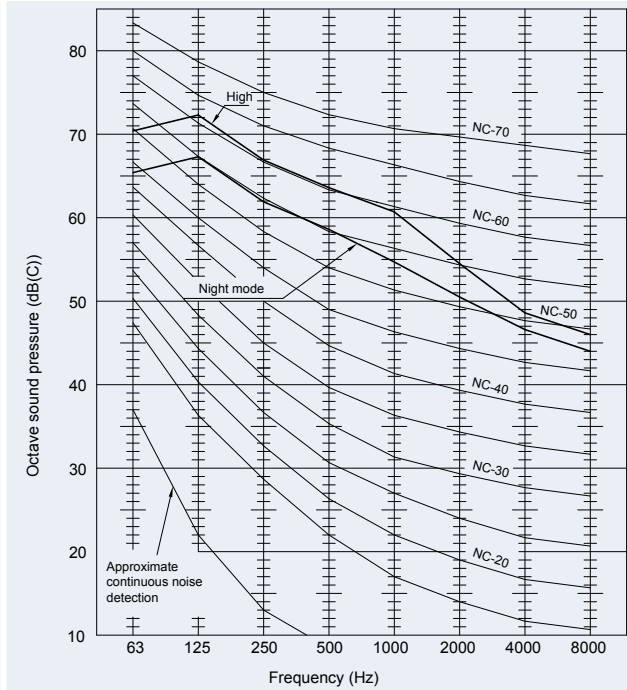
Sound pressure level: Global (night mode); 66 (61)

**RAS-40FSXN**



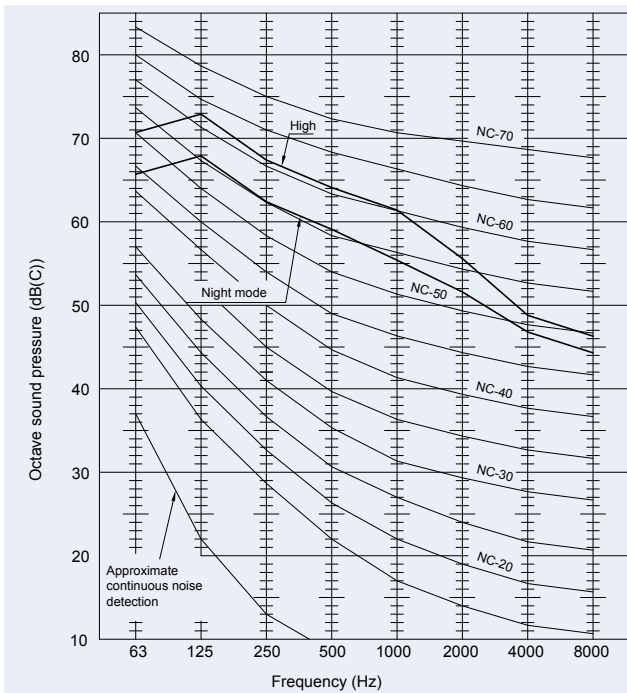
Sound pressure level: Global (night mode); 66 (61)

**RAS-42FSXN**



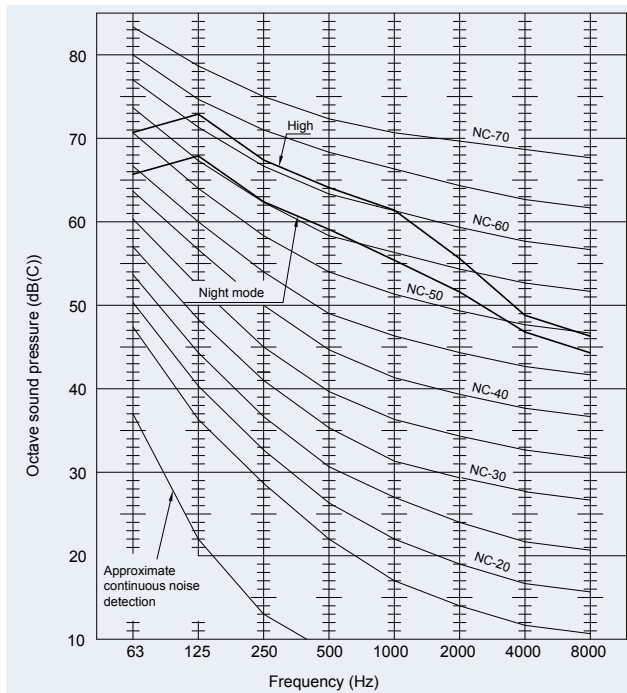
Sound pressure level: Global (night mode); 66 (61)

**RAS-44FSXN**

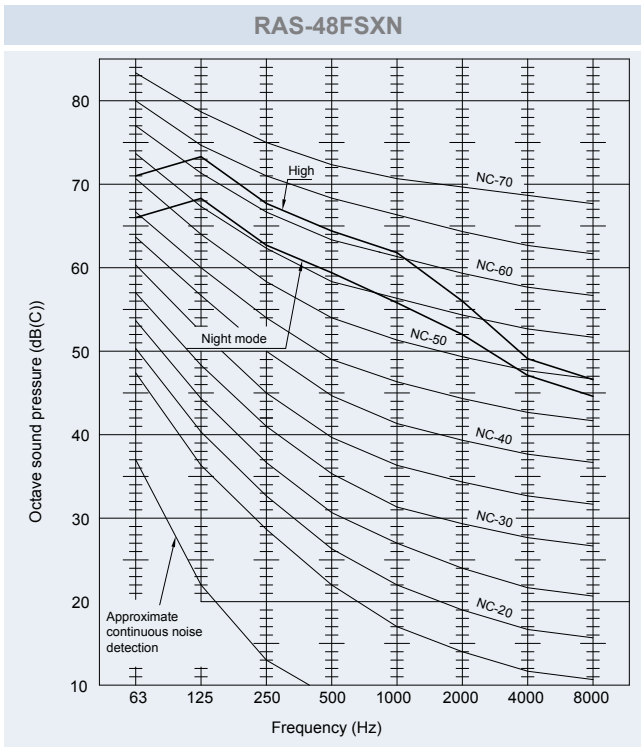


Sound pressure level: Global (night mode); 67 (62)

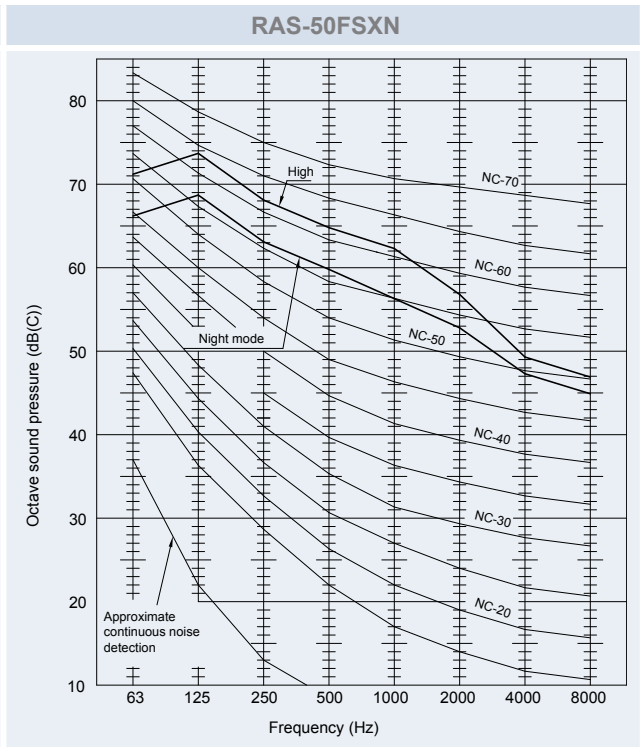
**RAS-46FSXN**



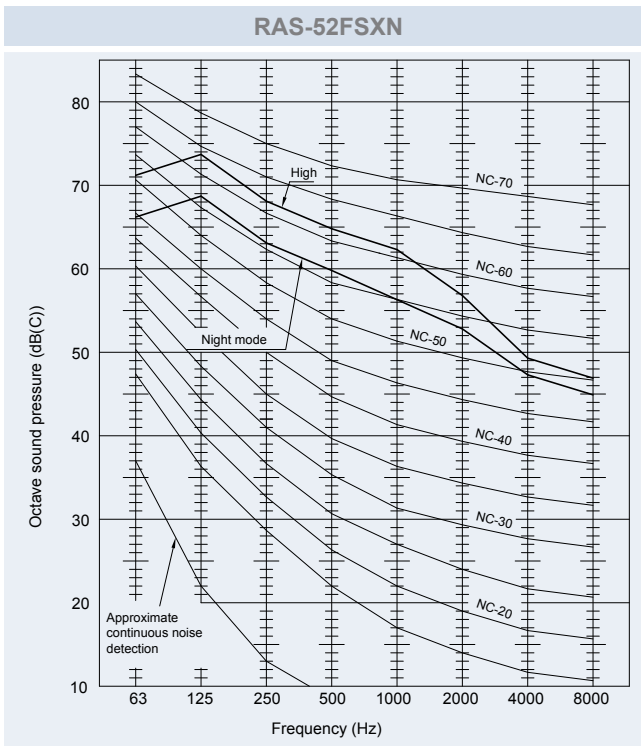
Sound pressure level: Global (night mode); 67 (62)



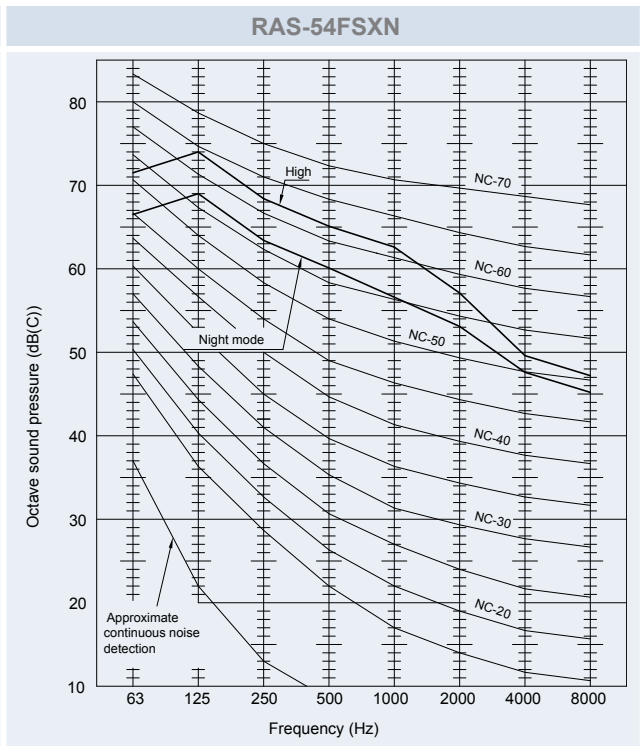
Sound pressure level: Global (night mode); 67 (62)



Sound pressure level: Global (night mode); 67 (62)



Sound pressure level: Global (night mode); 67 (62)



Sound pressure level: Global (night mode); 68 (63)



# 6. Working range

## Index

6.1	Voltage supply.....	178
6.2	Working range.....	179

## 6.1 Voltage supply

### Service voltage

Between 90 and 110% of the rated voltage.

### Start-up voltage

Between 85 and 115% of the rated voltage.

### Voltage imbalance

Up to 3% in each phase, measured at the main terminal of the outdoor unit.

### Electromagnetic compatibility

According to Directive 2004/108/EC (89/336/EEC) regarding electromagnetic compatibility, the following table indicates: the maximum allowed impedance  $Z_{max}$  of the system at the connection point of the user's power supply, as per EN61000-3-11.

Model	$Z_{max}$ ( $\Omega$ )	Model	$Z_{max}$ ( $\Omega$ )
RAS-8FSXN	—	RAS-14FSXN	0.11
RAS-10FSXN	—	RAS-16FSXN	0.11
RAS-12FSXN	—	RAS-18FSXN	0.08

### Harmonics

In relation to IEC 61000-3-2 and IEC 61000-3-12, the situation of harmonics for each model is as follows:

Situation of the models in relation to IEC 61000-3-2 and IEC 61000-3-12 Ssc "xx"	Model	
Unit compliant with IEC 61000-3-2 (professional use).	RAS-8FSXN	RAS-10FSXN
Unit compliant with IEC 61000-3-12.	—	—
The authorities responsible for the electrical power supply can apply restrictions relating to harmonics.	RAS-12FSXN	RAS-14FSXN
	RAS-16FSXN	RAS-18FSXN
Unit(s) outside the scope of IEC 61000-3-12.	—	—

## 6.2 Working range

This unit has been designed to cool to temperatures below  $-5\text{ }^{\circ}\text{C}$ . This feature allows the cooling of buildings with high internal heat retentions due to the lighting systems, people and machines, especially in areas such as shops, conference rooms, data processing areas, etc. Heating can be carried out at ambient temperatures below  $-20\text{ }^{\circ}\text{C}$ .

This heat pump and heat recovery system has been designed for the following temperatures. Use the system within this range.

The system can provide refrigeration or heating (heat pump system) or can provide refrigeration and heating simultaneously (heat recovery system).

The following table indicates the temperature range.

Mode		Cooling	Heating
Indoor temperature	Min.	21 °C DB / 15 °C WB	15 °C DB
	Max.	32 °C DB / 23 °C WB	27 °C DB
Outdoor temperature	Min.	$-5\text{ }^{\circ}\text{C DB}^{(1)}$	$-20\text{ }^{\circ}\text{C WB}^{(2)}$
	Max.	43 °C DB	15 °C WB

(1)  $(10 - -5)\text{ }^{\circ}\text{C DB}$ , operating control range.

(2)  $(-12 - -20)\text{ }^{\circ}\text{C WB}$ , operating control range.



### NOTE

**DB: dry bulb; WB: wet bulb.**

Operation in cooling mode

A: outdoor air temperature.

B: indoor air inlet temperature.

C: working range in cooling mode.

D: operating control range.



### NOTE

**DB: dry bulb; WB: wet bulb.**

Operation in heating mode

A: outdoor air temperature.

B: indoor air inlet temperature.

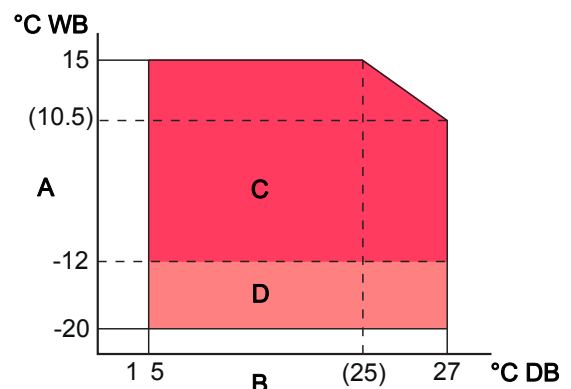
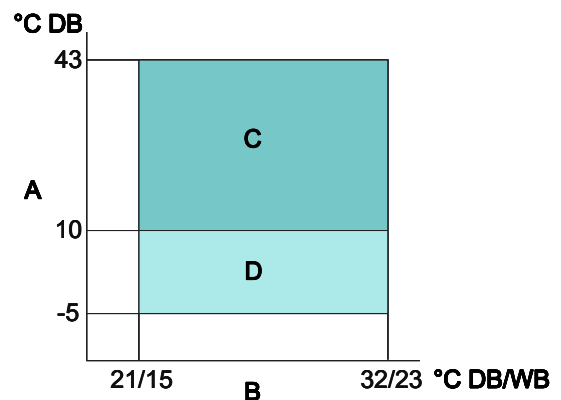
C: working range in heating mode.

D: operating control range.



### NOTE

**DB: dry bulb; WB: wet bulb.**



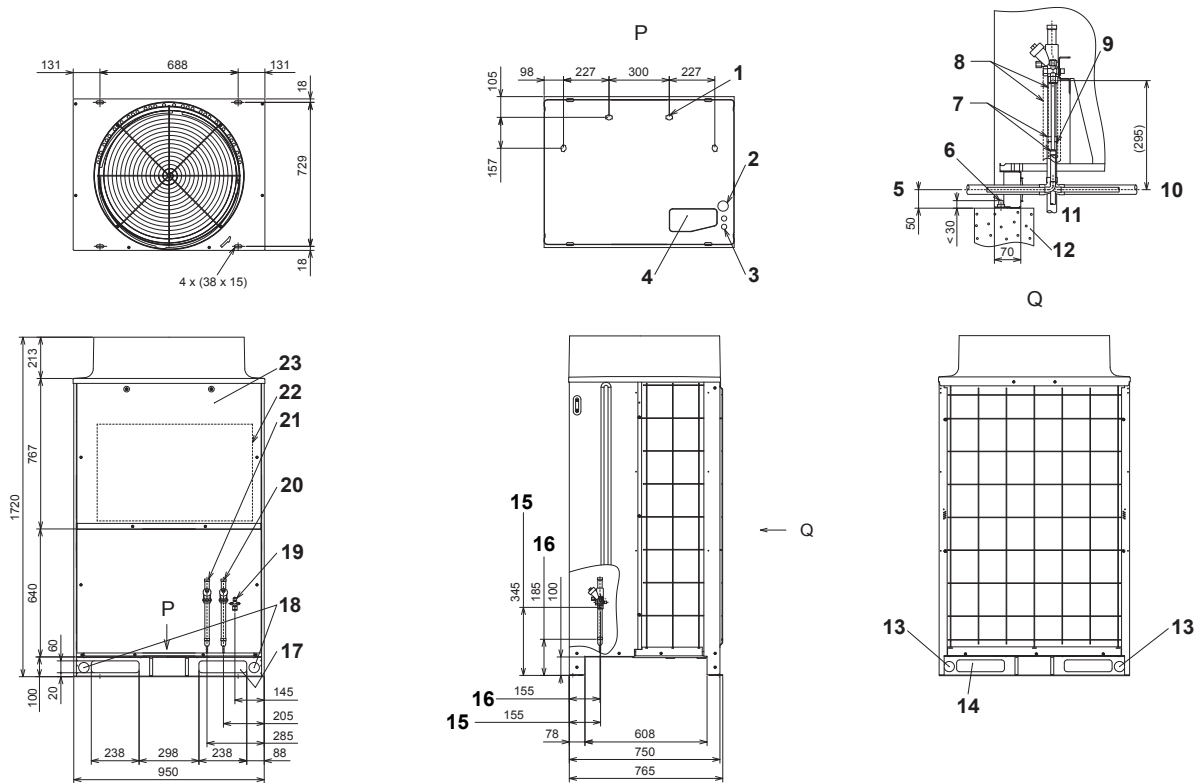


# 7 . General dimensions

## Index

7.1	Dimensions RAS-(8-12)FSXN.....	182
7.2	Dimensions RAS-(14-18)FSXN.....	183
7.3	Dimensions CH-(6.0-10.0)N1.....	184
7.4	Service space.....	185

## 7.1 Dimensions RAS-(8-12)FSXN

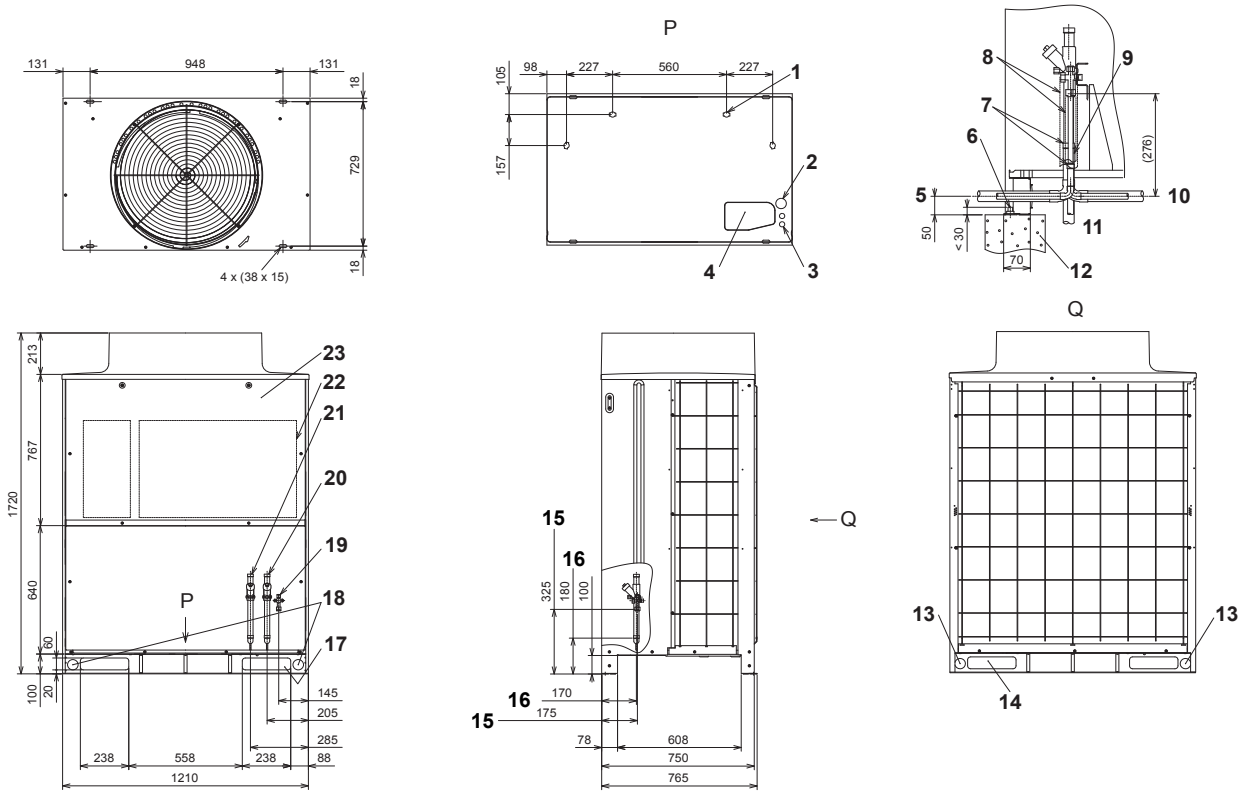


1	Hole for condensate drainage (ø26 x 4)	13	Hole for power supply cables (ø52 x 2)
2	Hole for power supply cables (ø52)	14	Hole for refrigerant pipes and control wires
3	Hole for control cables (ø26 x 2)	15	Liquid refrigerant line
4	Hole for refrigerant pipes (235 x 113)	16	Gas refrigerant line
5	Laying of pipes at front	17	Hole for refrigerant pipes and control wires
6	M12 anchor bolt	18	Hole for power supply cables (ø52 x 2)
7	Welding	19	Refrigerant pipe connection (liquid) øC
8	Insulation	20	Refrigerant pipe connection (gas, high pressure) øB
9	Accessory pipe	21	Refrigerant pipe connection (gas, low pressure) øA
10	Laying of pipes at back	22	Electrical box
11	Laying of standard pipes	23	Service cover
12	Concrete base		

Heat pump system (2 pipes)				Heat recovery system (3 pipes)			
Model	A	B	C	Model	A	B	C
RAS-8FSXN	-	19.05	9.53	RAS-8FSXN	19.05	15.88	9.53
RAS-10FSXN	-	22.2	9.53	RAS-10FSXN	22.2	19.05	9.53
RAS-12FSXN	-	25.4	12.7	RAS-12FSXN	25.4	22.2	12.7

All measurements are in mm.

## 7.2 Dimensions RAS-(14-18)FSXN



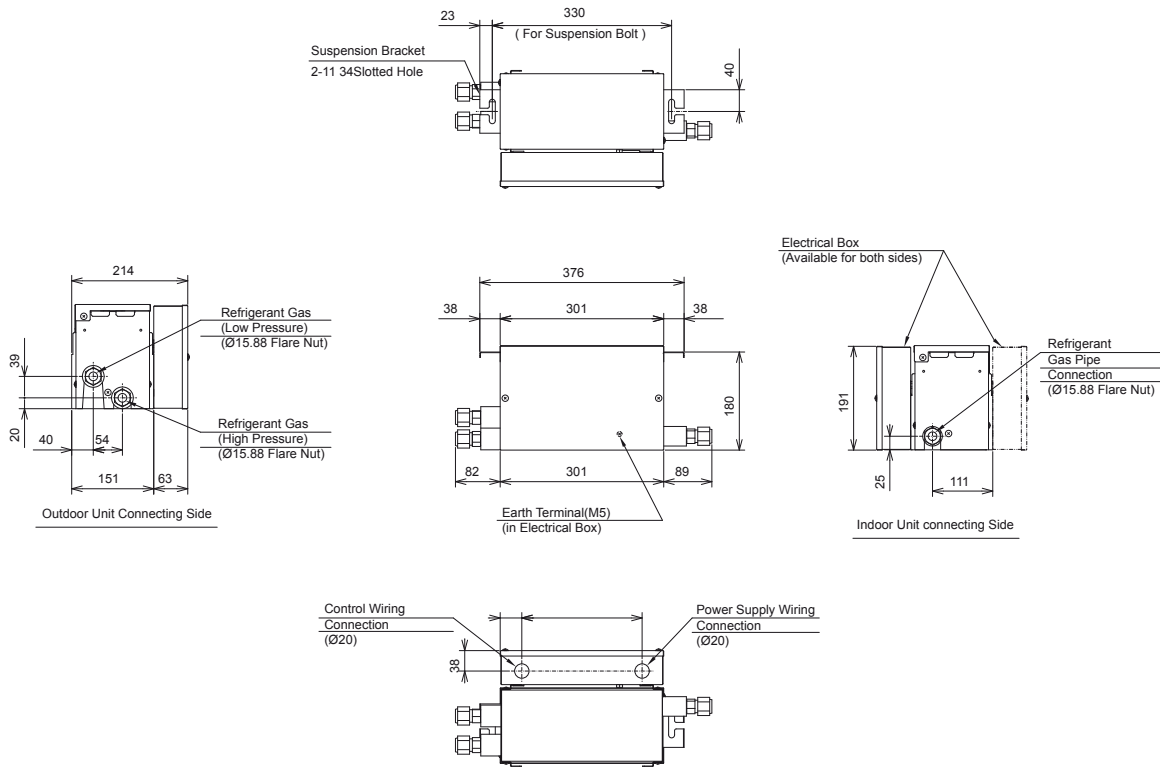
7

1	Hole for condensate drainage ( $\varnothing 26 \times 4$ )	13	Hole for power supply cables ( $\varnothing 52 \times 2$ )
2	Hole for power supply cables ( $\varnothing 52$ )	14	Hole for refrigerant pipes and control wires
3	Hole for control cables ( $\varnothing 26 \times 2$ )	15	Liquid refrigerant line
4	Hole for refrigerant pipes (245 x 138)	16	Gas refrigerant line
5	Laying of pipes at front	17	Hole for refrigerant pipes and control wires
6	M12 anchor bolt	18	Hole for power supply cables ( $\varnothing 52 \times 2$ )
7	Welding	19	Refrigerant pipe connection (liquid) $\varnothing C$
8	Insulation	20	Refrigerant pipe connection (gas, high pressure) $\varnothing B$
9	Accessory pipe	21	Refrigerant pipe connection (gas, low pressure) $\varnothing A$
10	Laying of pipes at back	22	Electrical box
11	Laying of standard pipes	23	Service cover
12	Concrete base		

Heat pump system (2 pipes)				Heat recovery system (3 pipes)			
Model	A	B	C	Model	A	B	C
RAS-14FSXN	-	25.4	12.7	RAS-14FSXN	25.4	22.2	12.7
RAS-16FSXN	-	28.6	12.7	RAS-16FSXN	28.6	22.2	12.7
RAS-18FSXN	-	28.6	15.88	RAS-18FSXN	28.6	22.2	15.88

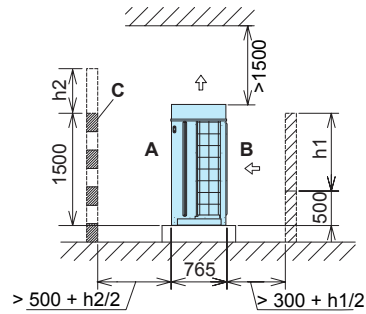
All measurements are in mm.

### 7.3 Dimensions CH-(6.0-10.0)N1





## 7.4 Service space



### NOTE

*Side view. All measurements are in mm.*

Calculate the service space required during the installation of the unit, based on the following:

- If there are no walls either in front or behind the unit, a space of 500 mm is necessary in front -A- and 300 mm behind -B-.
- If the front wall is higher than 1500 mm, a space of  $(500 + h2/2)$  mm is required at the front -A-.
- If the rear wall is higher than 500 mm, a space of  $(300 + h1/2)$  mm is required at the back -B-.
- If a wall -C- is installed in front of the unit, a ventilation hole should be made in the wall.
- When the space over the unit is less than 1500 mm, or the space around the unit is closed, a conduct is required to prevent short-circuits between the intake air and the discharge air.
- If there are any obstacles in the space over the unit, the four sides of the unit should be left open.

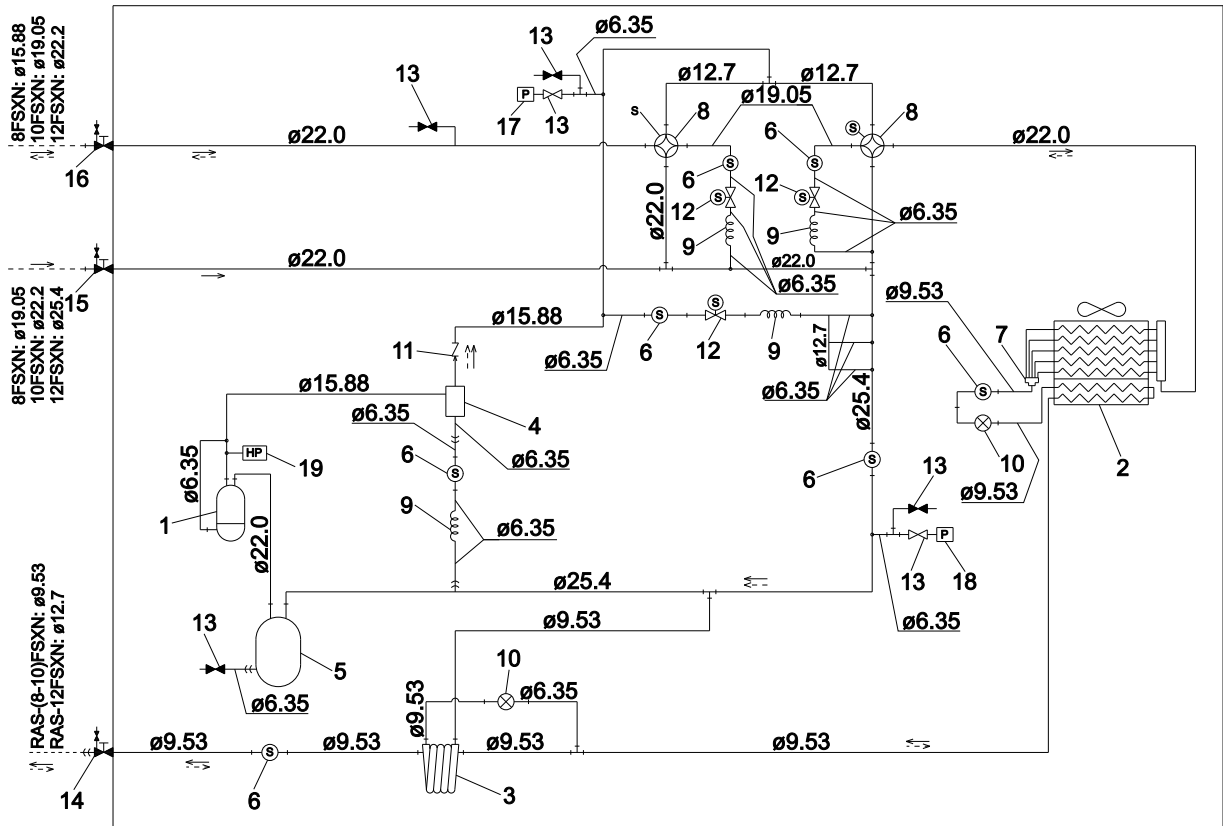


# 8. Refrigerant cycle

## Index

8.1	RAS-(8-12)FSXN.....	188
8.2	RAS-(14-18)FSXN.....	189
8.3	CH-(6.0-10.0)N1.....	190

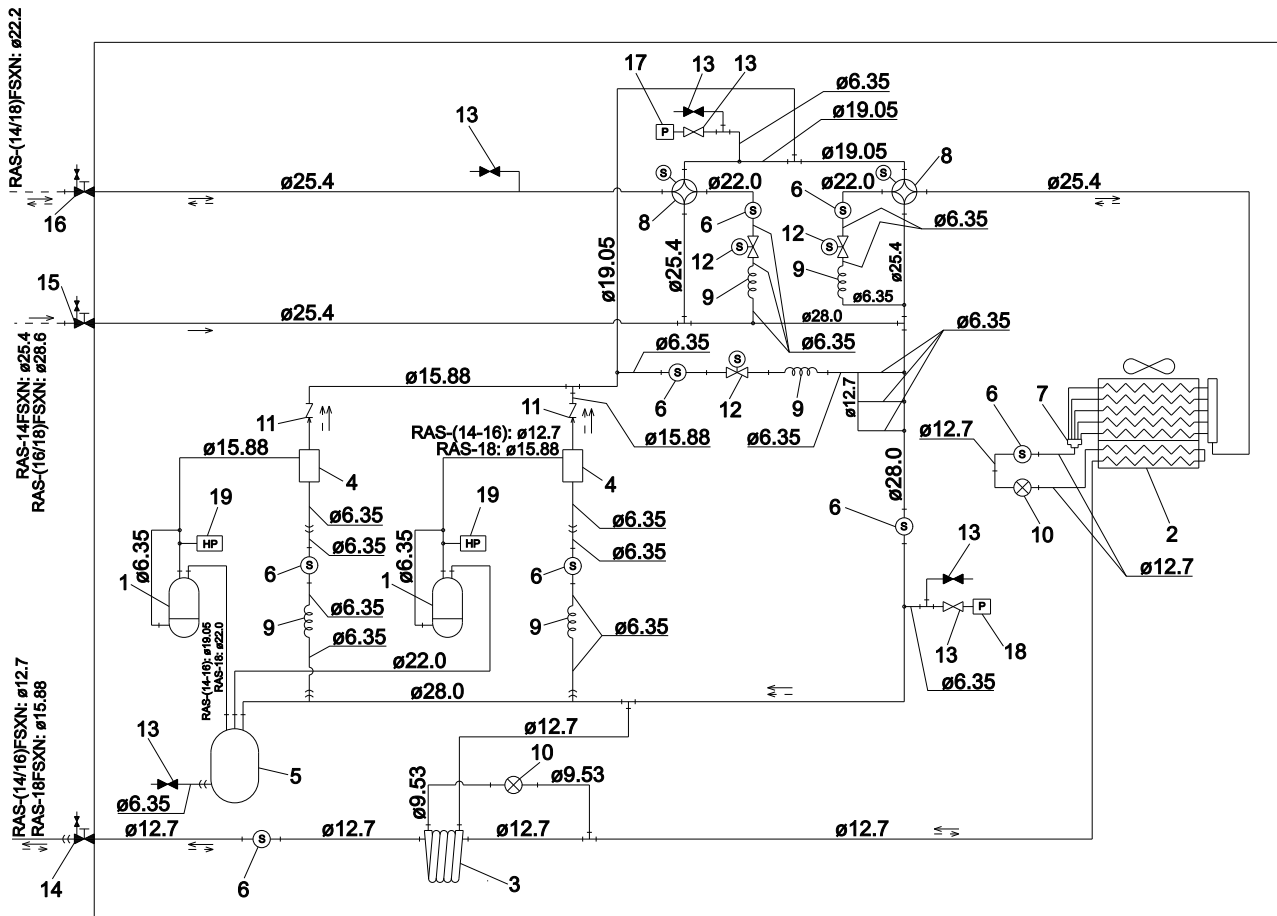
**8.1 RAS-(8-12)FSXN**



←	← - -	- - -	→ - -	— + —
Refrigerant flow for cooling	Refrigerant flow for heating	Installation refrigerant pipe	Connection by flare nut	Connection by welding

Part	No.	Part	No.
1	Compressor	11	Check valve
2	Heat exchanger	12	Solenoid valve
3	Dual-tube heat exchanger	13	Check joint
4	Oil separator	14	Stop valve (liquid)
5	Accumulator	15	Stop valve (gas, low pressure)
6	Filter	16	Stop valve (gas, high pressure)
7	Distributor	17	Refrigerant pressure sensor (high pressure)
8	Reversing valve	18	Refrigerant pressure sensor (low pressure)
9	Capillary tube	19	Protection pressure switch
10	Electronic expansion valve		

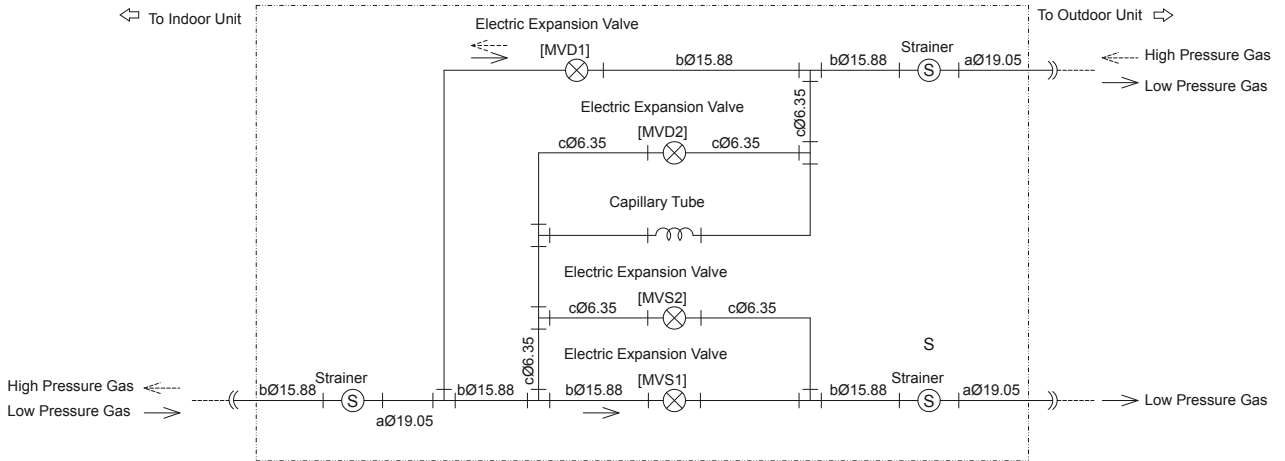
## 8.2 RAS-(14-18)FSXN



←	← - -	- - -	→	+ - -
Refrigerant flow for cooling	Refrigerant flow for heating	Installation refrigeration pipe	Connection by flare nut	Connection by welding

Part	No.	Part	No.
1	Compressor	11	Check valve
2	Heat exchanger	12	Solenoid valve
3	Dual-tube heat exchanger	13	Check joint
4	Oil separator	14	Service valve (liquid)
5	Accumulator	15	Service valve (gas, low pressure)
6	Filter	16	Service valve (gas, high pressure)
7	Distributor	17	Refrigerant pressure sensor (high pressure)
8	Reversing valve	18	Refrigerant pressure sensor (low pressure)
9	Capillary tube	19	Protection pressure switch
10	Electronic expansion valve		

**8.3 CH-(6.0-10.0)N1**



←	← - -	- - -	→ - -	-   -
Refrigerant flow for cooling	Refrigerant flow for heating	Installation refrigeration pipe	Connection by flare nut	Connection by welding

# 9. Piping work and refrigerant charge

## Index

9.1	Refrigerant pipe selection.....	192
9.1.1	Pipe size selection.....	192
9.2	Copper pipes, sizes, connection and insulation.....	193
9.2.1	Copper pipes and sizes.....	193
9.2.2	Pipe connection.....	193
9.3	Pipe connection kit.....	195
9.3.1	SET FREE FSXN (two pipes).....	195
9.3.2	SET FREE FSXN (three pipes).....	196
9.4	Multi-Kits.....	199
9.4.1	2-pipe Multi-Kit (Optional Parts).....	199
9.4.2	3-pipe Multi-Kit (Optional Parts).....	199
9.5	Precautions for the installation of the outdoor unit.....	201
9.6	Provision of pipes.....	203
9.7	Connection of refrigerant pipes for heat pump (2 pipes).....	204
9.7.1	Pipe sizes for RAS-(8-18)FSXN (Base unit).....	204
9.7.2	Pipe sizes for RAS-(20-36)FSXN (Combination of two units).....	204
9.7.3	Pipe sizes for RAS-(38-54)FSXN (Combination of three units).....	205
9.7.4	Pipe connection kit (optional).....	206
9.7.5	Example of installation (38 HP: 2 pipes).....	206
9.7.6	Size of pipes (ø mm) and selection of multikit (2 pipes).....	207
9.8	Connection of refrigerant pipes for heat recovery (3 pipes).....	210
9.8.1	Pipe sizes for RAS-(8-18)FSXN (Base unit).....	210
9.8.2	Pipe sizes for RAS-(20-36)FSXN (Combination of two units).....	210
9.8.3	Pipe sizes for RAS-(38-54)FSXN (Combination of three units).....	211
9.8.4	Pipe connection kit (optional).....	212
9.8.5	Example of installation (38 HP: 3 pipes).....	213
9.8.6	Size of pipes (ø mm) and selection of multikit (3 pipes).....	213
9.9	Refrigerant charge.....	218
9.9.1	Installation airtight test.....	218
9.9.2	Installation vacuum.....	219
9.9.3	Quantity of refrigerant charged in the W0 outdoor unit.....	219
9.9.4	Maximum additional refrigerant charge.....	219
9.9.5	Method of calculation of the total additional refrigerant charge.....	219
9.9.6	Refrigerant charge.....	220
9.9.7	Automatic system to estimate the amount of refrigerant charged in the unit.....	221
9.10	Precautions in the event of refrigerant leaks.....	223
9.10.1	Maximum permitted concentration of hydrofluorocarbon (HFC).....	223
9.10.2	Calculation of the refrigerant concentration.....	223
9.10.3	Countermeasures in the event of refrigerant leaks.....	224

## 9.1 Refrigerant pipe selection

The RAS-(8-54)FSXN outdoor units can work as a heat pump system, by means of a two-pipe system (gas pipe and liquid pipe), or they can work as a heat recovery system by means of a three-pipe system (high and low pressure pipes and liquid pipe), requiring in addition the CH units supplied as accessories.

There is an optional specific pipe connection kit available according to the power of the outdoor unit:

Operating mode	Outdoor unit	No. of units	Connection kit	Indications:
Heat pump system	RAS-(20-24)FSXN	2	MC-20AN	<ul style="list-style-type: none"> <li>Gas pipe: 1 set.</li> <li>Liquid pipe: 1 set.</li> </ul>
	RAS-(26-36)FSXN	2	MC-21AN	
	RAS-(38-54)FSXN	3	MC-30AN	
Heat recovery system	RAS-(20-24)FSXN	2	MC-20XN	<ul style="list-style-type: none"> <li>Gas pipe, high pressure: 1 set.</li> <li>Gas pipe, low pressure: 1 set.</li> <li>Liquid pipe: 1 set.</li> </ul>
	RAS-(26-36)FSXN	2	MC-21XN	
	RAS-(38-54)FSXN	3	MC-30XN	

### 9.1.1 Pipe size selection

Select the pipe size in line with the following instructions:

- 1 Between the outdoor unit and the branch pipe (multikit): select the same pipe connection size as for the outdoor unit.
- 2 Between the branch pipe (multikit) and the indoor unit: select the same pipe connection size as for the indoor unit.



#### CAUTION

- **Do not use refrigerant pipe sizes other than those indicated in this manual. The diameter of the refrigerant pipes depends directly on the power of the outdoor unit.**
- **If larger diameter refrigerant pipes are used, the circuit lubrication oil tends to separate from the gas carrying it. The compressor will be seriously damaged due to a lack of lubrication.**
- **If smaller diameter refrigerant pipes are used, the gas or liquid refrigerant will have serious difficulties in circulating. System performance will be affected. The compressor will run under more severe conditions than foreseen and will be damaged in a short space of time.**



## 9.2 Copper pipes, sizes, connection and insulation

### 9.2.1 Copper pipes and sizes



#### CAUTION

- *The copper pipe used in the refrigeration installations is different to the copper pipe used in installations carrying domestic or heating water.*
- *The copper pipe for refrigeration installations is especially treated for outdoors and indoors. The interior surface finish makes it easier for the refrigerant to circulate and withstands the action of the lubricant oil applied to outdoor equipment.*

Prepare the copper pipes provided by the supplier.

Select the pipe with the appropriate diameter and thickness. Use the table below to select the most appropriate pipe:

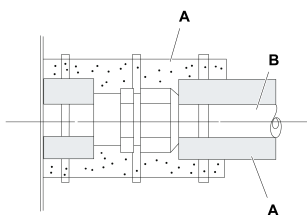
Nominal diameter		Thickness mm	Supply	Nominal diameter		Thickness mm	Supply
mm	Inches			mm	Inches		
6.35	1/4	0.80	Roll	25.4	1	1.00	Pipe
9.53	3/8	0.80	Roll	28.6	1-1/8	1.00	Pipe
12.7	1/2	0.80	Roll	31.75	1-1/4	1.10	Pipe
15.88	5/8	1.00	Roll	38.1	1-1/2	1.35	Pipe
19.05	3/4	1.00	Pipe	41.3	1-5/8	1.45	Pipe
22.2	7/8	1.00	Pipe	44.45	1-3/4	1.55	Pipe

Always use clean copper pipes with no signs of knocks or cracks. Make sure there is no dust or dampness on the inside. Before you install the pipes, clean the inside with oxygen-free nitrogen gas to eliminate any remains of dust or other substances.



#### CAUTION

- *Do not use hand saws, circular saws, abrasive grinders or other tools that generate shavings.*
- *Strictly follow national or local regulations regarding occupational health and safety.*
- *Wear appropriate means of protection during cutting or brazing operations and installation (gloves, eye protection, etc).*



On completing the installation of the refrigerant pipes -B-, insulate them appropriately using suitable insulating material -A- and seal the open space between the holes made and the pipe, as shown in the figure.

### 9.2.2 Pipe connection

Cover the end of the pipe appropriately when it is to be inserted through holes in walls and roofs, etc.

Keep the ends of the pipes covered while other installation work is being carried out to avoid the entry of dampness or dirt.

Do not place the pipes directly on the ground without appropriate protection or adhesive vinyl tape to cover the ends.

Where the pipe installation is not completed for a certain amount of time, braze the ends of the pipe to seal. Then fill it with oxygen-free nitrogen gas through a Schrader valve to avoid the accumulation of humidity and/or contamination through dirt.





**NOTE**

- ***Where polyethylene foam insulation is used, a 10 mm thick layer should be used for the liquid pipe and between 15 and 20 mm for the gas pipe.***
- ***Install the insulation after the pipe surface temperature has dropped to the same temperature as that of the room, otherwise the insulation may melt.***

Do not use insulating material that contains  $\text{NH}_3$  (ammonium), as it could damage the copper in the pipe and subsequently cause leaks.

Where the fitter has supplied his own branches, these should be appropriately insulated to avoid decreases in capacity in line with to environmental conditions and dew on the surface of the piping due to low pressure.

## 9.3 Pipe connection kit

### 9.3.1 SET FREE FSXN (two pipes)

Key:

ID: inner diameter.

Quantity: 1.

A: towards the outdoor unit.

C: towards connection kit 1.

OD: outer diameter.

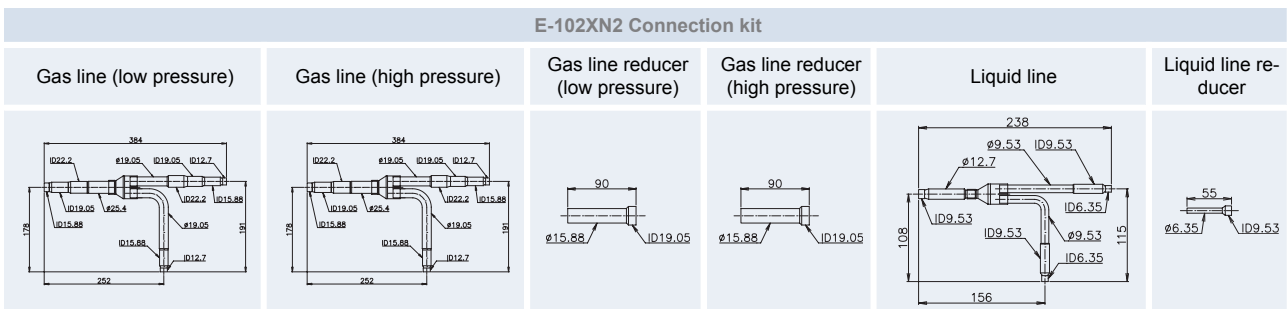
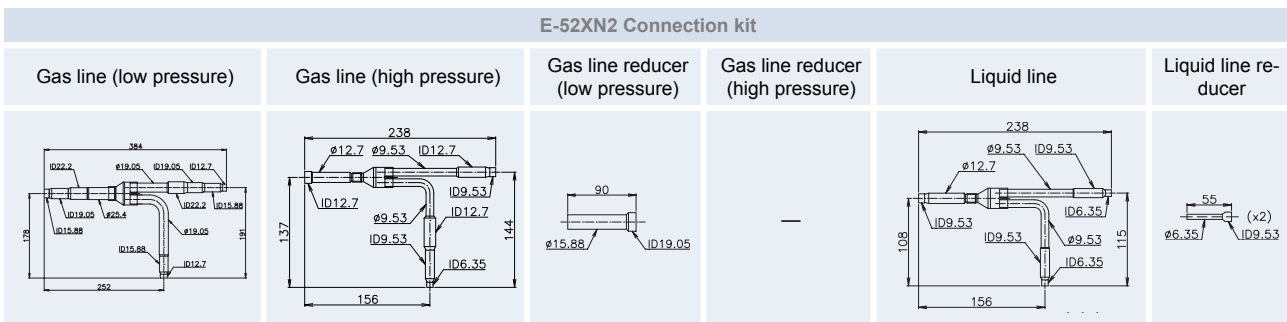
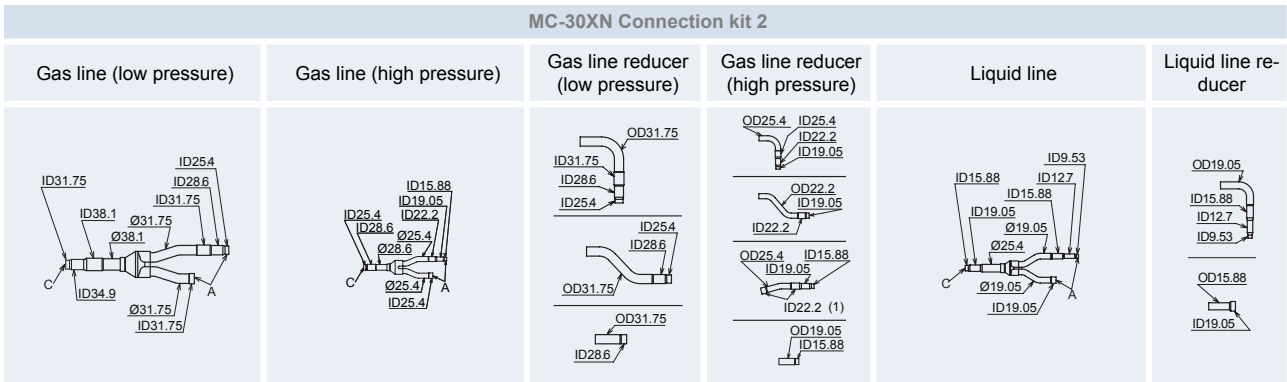
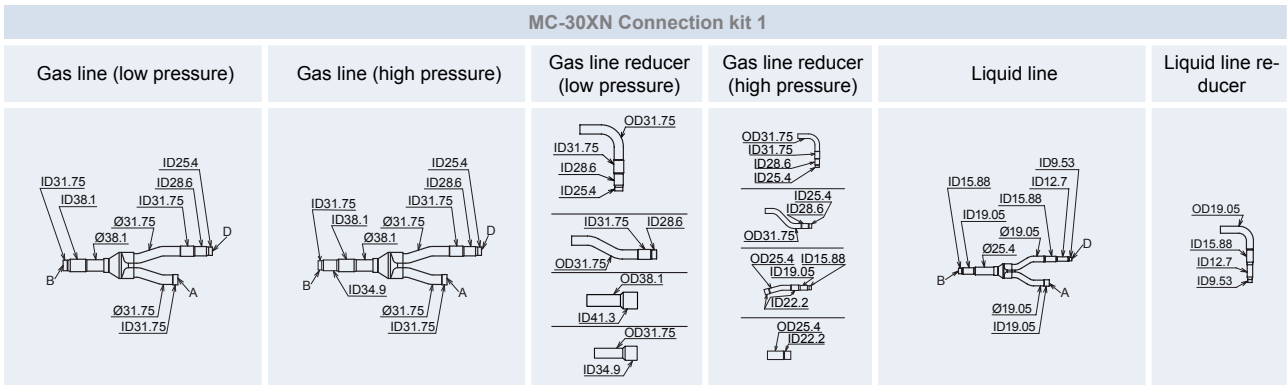
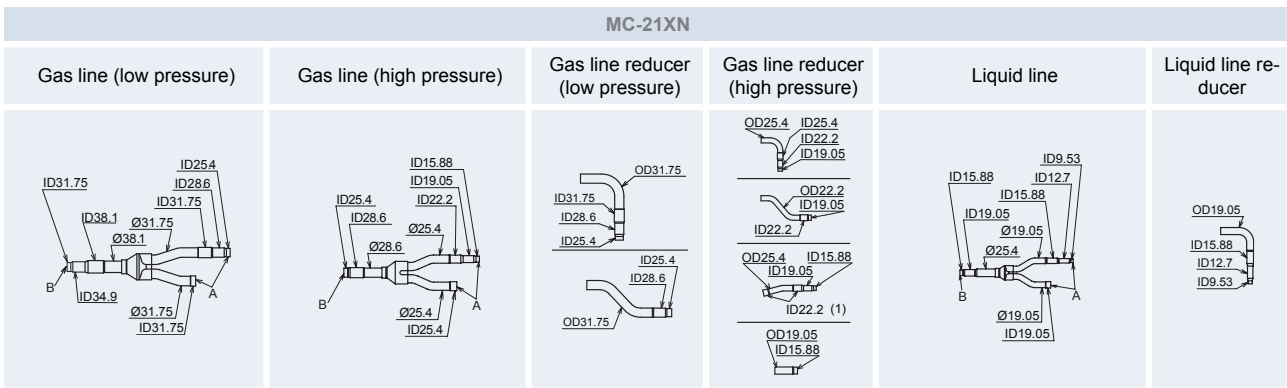
All measurements are in mm.

B: towards the indoor unit.

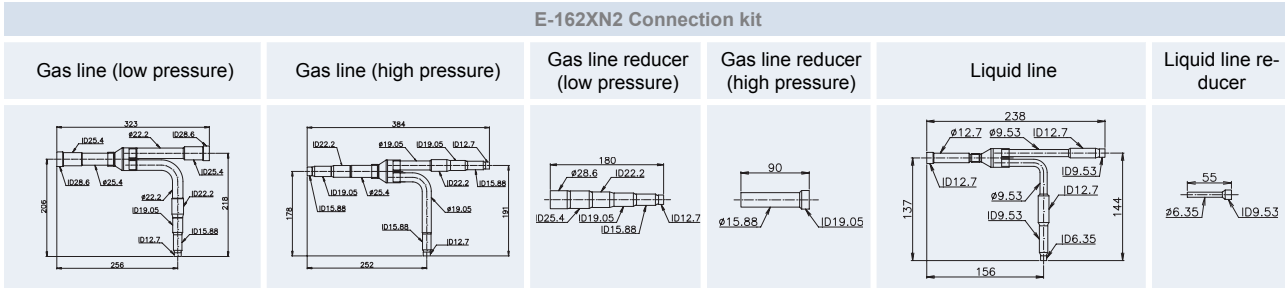
D: towards connection kit 2.

MC-20AN			
Gas line	Gas line reducer	Liquid line	Liquid line reducer
MC-21AN			
Gas line	Gas line reducer	Liquid line	Liquid line reducer
MC-30AN Connection kit			
Gas line	Gas line reducer	Liquid line	Liquid line reducer
MC-30AN Connection kit			
Gas line	Gas line reducer	Liquid line	Liquid line reducer

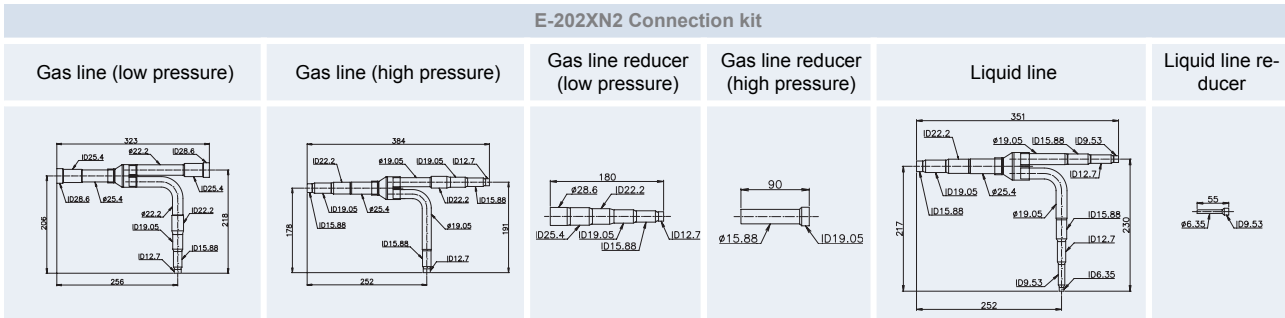




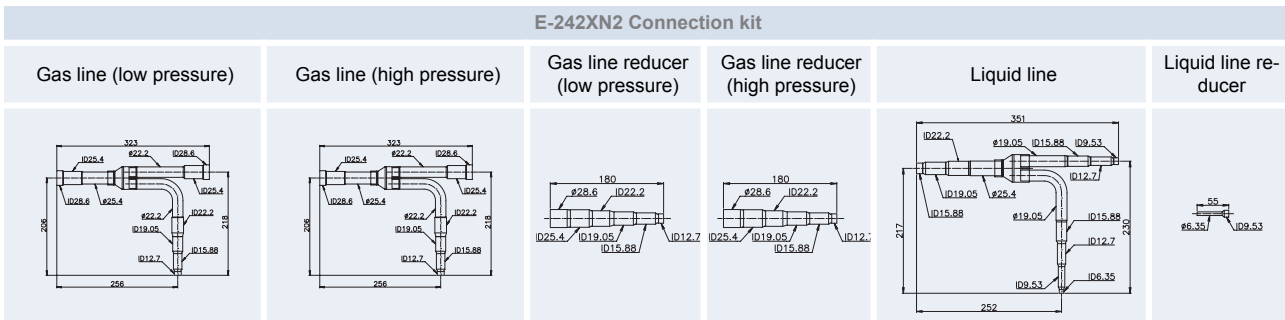
**E-162XN2 Connection kit**



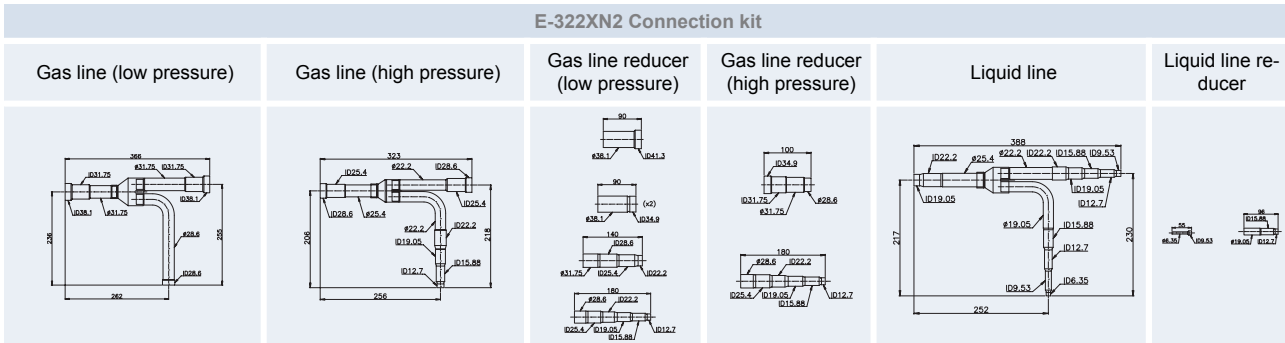
**E-202XN2 Connection kit**



**E-242XN2 Connection kit**



**E-322XN2 Connection kit**



## 9.4 Multi-Kits

### 9.4.1 2-pipe Multi-Kit (Optional Parts)

#### Branch line

#### First branch

Outdoor unit HP	Model
8/10	E-102SN2
12-16	E-162SN2
18-24	E-242SN2
26-54	E-302SN2

#### Piping and Multi-Kit diameter after the first branch

Total HP of the indoor unit	Gas (Ømm)	Liquid (Ømm)	Model
<6	Ø15.88	Ø9.53	E-102SN2
6-8.99	Ø19.05	Ø9.53	
9-11.99	Ø22.2	Ø9.53	
12-15.99	Ø25.4	Ø12.7	E-162SN2
16-17.99	Ø28.6	Ø12.7	
18-25.99	Ø28.6	Ø15.88	E-242SN2
26-35.99	Ø31.75	Ø19.05	E-302SN2
>36	Ø38.1	Ø19.05	

#### Manifold branch

Total HP of the indoor unit	No. of manifold branches	Model
5-8	4	MH-84AN
5-10	8	MH-108AN

### 9.4.2 3-pipe Multi-Kit (Optional Parts)

#### Branch line

#### First branch

Outdoor unit HP	Model
8/10	E-102XN2
12-16	E-162XN2
18-20	E-202XN2
22-24	E-242XN2
26-54	E-322XN2

#### Piping and Multi-Kit diameter after the first branch \*

Total HP of the indoor unit	Low pressure Gas (Ømm)	High pressure Gas (Ømm)	Liquid (Ømm)	Model
<6	Ø15.88	Ø12.7	Ø9.53	E-52XN2
6-8.99	Ø19.05	Ø15.88	Ø9.53	E-102XN2
9-11.99	Ø22.2	Ø19.05	Ø9.53	
12-15.99	Ø25.4	Ø22.2	Ø12.7	E-162XN2
16-17.99	Ø28.6	Ø22.2	Ø12.7	

Total HP of the indoor unit	Low pressure Gas (Ømm)	High pressure Gas (Ømm)	Liquid (Ømm)	Model
18-21.99	Ø28.6	Ø22.2	Ø15.88	E-202XN2
22-25.99	Ø28.6	Ø25.4	Ø15.88	E-242XN2
26-35.99	Ø31.75	Ø28.6	Ø19.05	E-322XN2
>36	Ø38.1	Ø31.75	Ø19.05	

**NOTE**

- *If the piping branch requires 2 portions of piping, use Multi-kit E-102SN2, E-162SN2, E-242SN2 for the heat pump operation.*

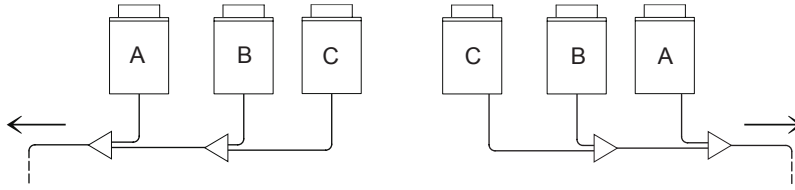
**Manifold branch**

Total HP of the indoor unit	No. of manifold branches	Model
5-10	8	MH-108AN



## 9.5 Precautions for the installation of the outdoor unit.

### Order of installation of the units

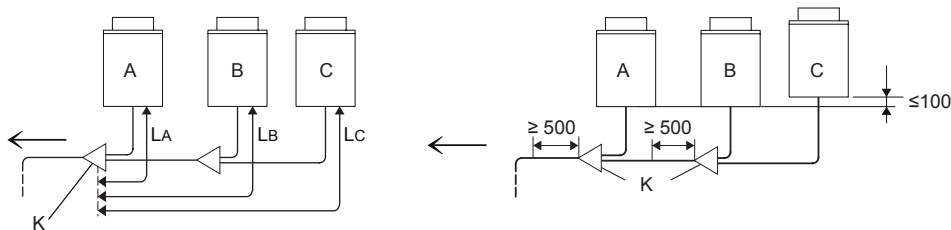


The outdoor units must be installed in decreasing order of capacity:

Capacity of unit A  $\geq$  capacity of unit B  $\geq$  capacity of unit C.

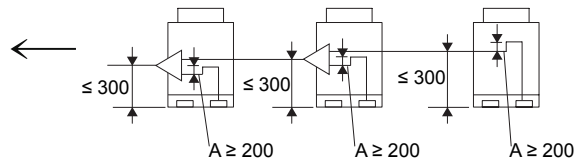
Unit -A-, with the highest capacity, must be closest the indoor units.

### Refrigerant pipe installation between outdoor units

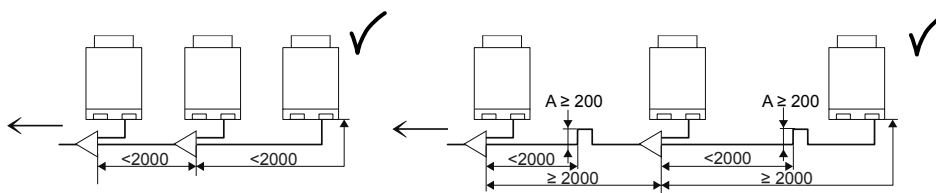


The length between the connection kit -K- (on the side of the outdoor unit) and the outside unit, must be  $L_A \leq L_B \leq L_C \leq 10$  m.

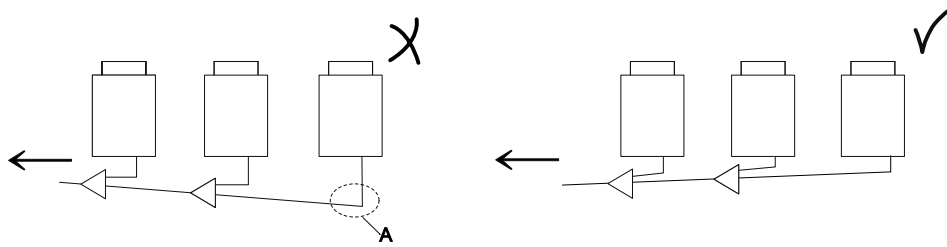
Place the connection kit at a lower level with respect to the connection of the refrigerant pipes of the outdoor unit.



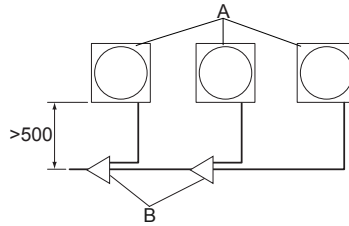
If the connection kit is placed above the refrigerant pipe connection of the outdoor unit, keep a maximum of 300 mm between the connection kit and the base of the outdoor unit. In addition, an oil recovery unit -A- (minimum 200 mm) should be fitted between the connection kit and the outdoor unit.



If the length of the refrigerant gas and liquid pipes between outdoor units is greater than two metres, the oil recovery unit should be fitted on the gas pipe to prevent the build-up of refrigerant oil.



Place the refrigerant pipes of the outdoor units horizontally, or slightly tilted towards the side of the indoor units to prevent the build-up of refrigerant oil at the lowest point -A-.

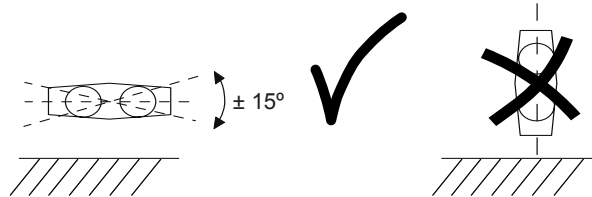


If the refrigerant pipes are opposite the outdoor unit, there should be a minimum of 500 mm between the outdoor units and the connection kits -B- for maintenance operations.



**NOTE**

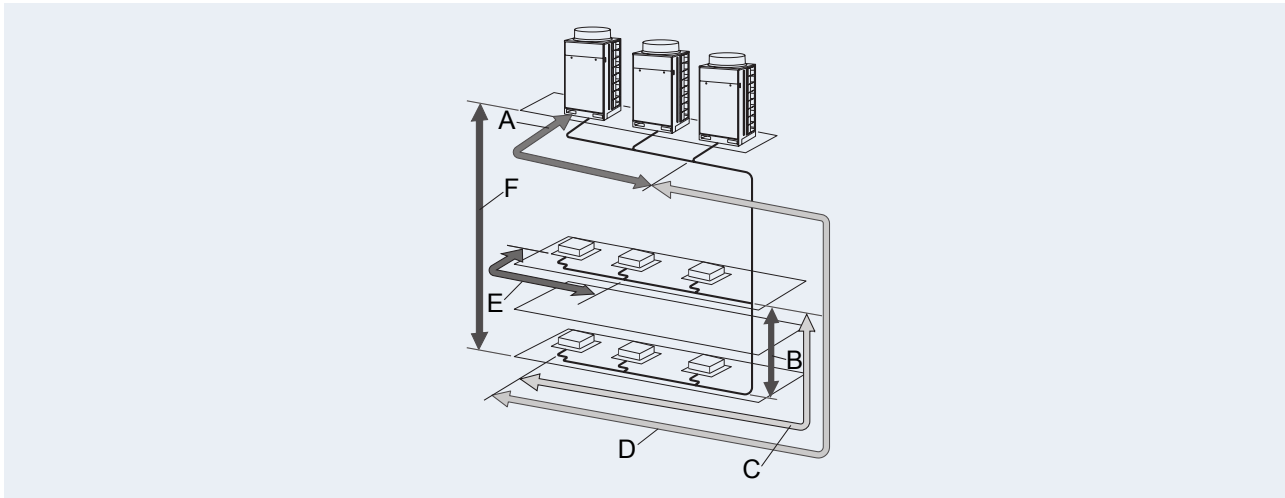
*The 500 mm space is required when replacing the unit compressor.*



Install the connection kits parallel to the floor ( $\pm 15^\circ$ ).

## 9.6 Provision of pipes

The maximum total length of the refrigerant pipes is 1000 m (300 m)<sup>1), 2)</sup> and the maximum length of the pipe between the first branch of the multikit and the last indoor unit connected is 90 m (40 m)<sup>2)</sup>.



A. Outdoor units. Maximum pipe length: 10 m. Difference in height: 0.1 m.

B. Difference in height of the indoor units: 15 m.

C. Maximum pipe length between the first branch of the multikit and the last indoor unit connected: 90 m (40 m)<sup>2)</sup>.

D. Length of pipe between outdoor and indoor units. Maximum pipe length: 165 m. Maximum total pipe length: 1000 m (300 m)<sup>1), 2)</sup>.

E. Maximum pipe length between the branch and the indoor unit: 40 m (30 m)<sup>2)</sup>.

F. Difference in height between the outdoor unit and the indoor units: 50 m (outdoor unit higher than the indoor units); 40 m (outdoor unit lower than the indoor units).

<sup>1)</sup> When the total length of the refrigerant pipes exceeds 300 m, the maximum additional refrigerant charge is restricted. The total additional charge (refrigerant pipes + indoor units) must not exceed the maximum additional refrigerant charge indicated in the following table.

Outdoor unit	Maximum additional refrigerant charge (kg)	Outdoor unit	Maximum additional refrigerant charge (kg)
RAS-(8/10)FSXN	28	RAS-(18-24)FSXN	51
RAS-12FSXN	36	RAS-(26-54)FSXN	63
RAS-(14/16)FSXN	40	—	—

<sup>2)</sup> If the refrigerant pipe length exceeds the values indicated in brackets, the maximum number of indoor units that can be connected must be less than that recommended in the following table.

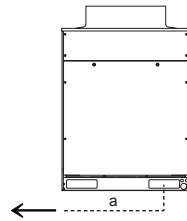
HP	8	10	12	14	16	18	20	22	24	26	28	30
Maximum number of connectable indoor units	13	16	19	23	26	26	33	36	40	43	47	50
Recommended number of connectable indoor units	8	10	10	16	16	16	18	20	26	26	32	32

HP	32	34	36	38	40	42	44	46	48	50	52	54
Maximum number of connectable indoor units	53	56	59	64	64	64	64	64	64	64	64	64
Recommended number of connectable indoor units	32	32	32	38	38	38	38	38	38	38	38	38

## 9.7 Connection of refrigerant pipes for heat pump (2 pipes)

### 9.7.1 Pipe sizes for RAS-(8-18)FSXN (Base unit)



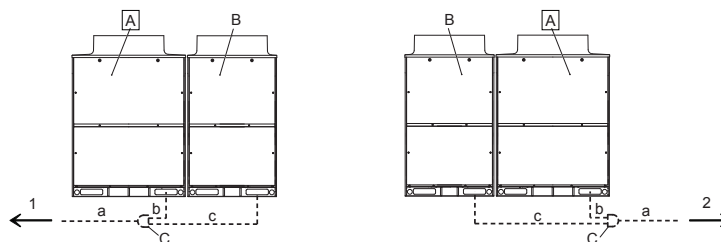
All measurements are in mm.

Model		RAS-8 FSXN	RAS-10 FSXN	RAS-12 FSXN	RAS-14 FSXN	RAS-16 FSXN	RAS-18 FSXN
a	Gas	Ø19.05	Ø22.2	Ø25.4	Ø25.4	Ø28.6	Ø28.6
	Liquid	Ø9.53	Ø9.53	Ø12.7	Ø12.7	Ø12.7	Ø15.88

If the main refrigerant pipe specified in the table is not available at the installation location, select the size given in brackets. In this case, prepare a suitable reducer.

Main pipe	Alternative pipe and reducer	Main pipe	Alternative pipe and reducer
Ø9.53	(Ø9.53-Ø12.7)	Ø22.2	(Ø22.2-Ø25.4)
Ø12.7	(Ø12.7-Ø15.88)	Ø25.4	(Ø25.4-Ø28.6)
Ø15.88	(Ø15.88-Ø19.05)	Ø28.6	(Ø28.6-Ø31.75)
Ø19.05	(Ø19.05-Ø22.2)	-	-

### 9.7.2 Pipe sizes for RAS-(20-36)FSXN (Combination of two units)



A: main outdoor unit; B: secondary outdoor unit; C: connection kit; 1: indoor units on left side; 2: indoor units on right side.

Install the outdoor units and connect the refrigerant pipes as shown in the diagram. Please refer to the table to determine the appropriate connection kit and the diameter of the pipes for each unit

All measurements are in mm.

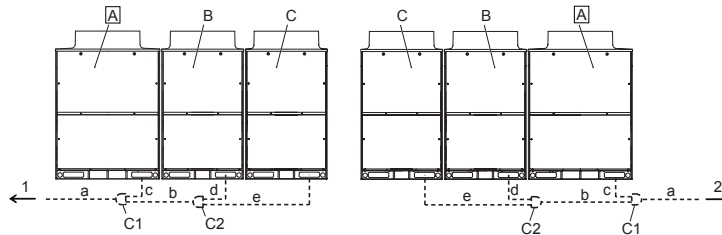
#### Combination of base units

Model	RAS-20 FSXN	RAS-22 FSXN	RAS-24 FSXN	RAS-26 FSXN	RAS-28 FSXN	RAS-30 FSXN	RAS-32 FSXN	RAS-34 FSXN	RAS-36 FSXN	
Unit A	RAS-12 FSXN	RAS-14 FSXN	RAS-14 FSXN	RAS-14 FSXN	RAS-14 FSXN	RAS-16 FSXN	RAS-16 FSXN	RAS-18 FSXN	RAS-18 FSXN	
Unit B	RAS-8 FSXN	RAS-8 FSXN	RAS-10 FSXN	RAS-12 FSXN	RAS-14 FSXN	RAS-14 FSXN	RAS-16 FSXN	RAS-16 FSXN	RAS-18 FSXN	
Connection kit	MC-20AN				MC-21AN					
a	Gas	Ø28.6	Ø28.6	Ø28.6	Ø31.75	Ø31.75	Ø31.75	Ø31.75	Ø31.75	Ø38.1
	Liquid	Ø15.88	Ø15.88	Ø15.88	Ø19.05	Ø19.05	Ø19.05	Ø19.05	Ø19.05	Ø19.05
b	Gas	Ø25.4	Ø25.4	Ø25.4	Ø25.4	Ø25.4	Ø28.6	Ø28.6	Ø28.6	Ø28.6
	Liquid	Ø12.7	Ø12.7	Ø12.7	Ø12.7	Ø12.7	Ø12.7	Ø12.7	Ø15.88	Ø15.88
c	Gas	Ø19.05	Ø19.05	Ø22.2	Ø25.4	Ø25.4	Ø25.4	Ø28.6	Ø28.6	Ø28.6
	Liquid	Ø9.53	Ø9.53	Ø9.53	Ø12.7	Ø12.7	Ø12.7	Ø12.7	Ø12.7	Ø15.88

If the main refrigerant pipe specified in the table is not available at the installation location, select the size given in brackets. In this case, prepare a suitable reducer.

Main pipe	Alternative pipe and reducer	Main pipe	Alternative pipe and reducer
Ø9.53	(Ø9.53-Ø12.7)	Ø25.4	(Ø25.4-Ø28.6)
Ø12.7	(Ø12.7-Ø15.88)	Ø28.6	(Ø28.6-Ø31.75)
Ø15.88	(Ø15.88-Ø19.05)	Ø31.75	(Ø31.75-Ø34.9)
Ø19.05	(Ø19.05-Ø22.2)	Ø38.1	(Ø38.1-Ø41.3)
Ø22.2	(Ø22.2-Ø25.4)	-	-

### 9.7.3 Pipe sizes for RAS-(38-54)FSXN (Combination of three units)



A: main outdoor unit; B: secondary outdoor unit; C: secondary outdoor unit; C1: connection kit 1; C2: connection kit 2; 1: indoor units on left side; 2: indoor units on right side.

Install the outdoor units and connect the refrigerant pipes as shown in the diagram. Please refer to the table to determine the appropriate connection kit and the diameter of the pipes for each unit.

All measurements are in mm.

#### Combination of base units

Model	RAS-38 FSXN	RAS-40 FSXN	RAS-42 FSXN	RAS-44 FSXN	RAS-46 FSXN	RAS-48 FSXN	RAS-50 FSXN	RAS-52 FSXN	RAS-54 FSXN
Unit A	RAS-14 FSXN	RAS-16 FSXN	RAS-18 FSXN	RAS-18 FSXN	RAS-18 FSXN	RAS-18 FSXN	RAS-18 FSXN	RAS-18 FSXN	RAS-18 FSXN
Unit B	RAS-12 FSXN	RAS-12 FSXN	RAS-12 FSXN	RAS-14 FSXN	RAS-16 FSXN	RAS-18 FSXN	RAS-18 FSXN	RAS-18 FSXN	RAS-18 FSXN
Unit C	RAS-12 FSXN	RAS-12 FSXN	RAS-12 FSXN	RAS-12 FSXN	RAS-12 FSXN	RAS-12 FSXN	RAS-14 FSXN	RAS-16 FSXN	RAS-18 FSXN
Connection kit	MC-30AN								
a	Gas	Ø38.1	Ø38.1	Ø38.1	Ø38.1	Ø38.1	Ø38.1	Ø38.1	Ø38.1
	Liquid	Ø19.05	Ø19.05	Ø19.05	Ø19.05	Ø19.05	Ø19.05	Ø19.05	Ø19.05
b	Gas	Ø28.6	Ø28.6	Ø28.6	Ø31.75	Ø31.75	Ø31.75	Ø31.75	Ø31.75
	Liquid	Ø15.88	Ø15.88	Ø15.88	Ø19.05	Ø19.05	Ø19.05	Ø19.05	Ø19.05
c	Gas	Ø25.4	Ø28.6	Ø28.6	Ø28.6	Ø28.6	Ø28.6	Ø28.6	Ø28.6
	Liquid	Ø12.7	Ø12.7	Ø15.88	Ø15.88	Ø15.88	Ø15.88	Ø15.88	Ø15.88
d	Gas	Ø25.4	Ø25.4	Ø25.4	Ø25.4	Ø28.6	Ø28.6	Ø28.6	Ø28.6
	Liquid	Ø12.7	Ø12.7	Ø12.7	Ø12.7	Ø12.7	Ø15.88	Ø15.88	Ø15.88
e	Gas	Ø25.4	Ø25.4	Ø25.4	Ø25.4	Ø25.4	Ø25.4	Ø28.6	Ø28.6
	Liquid	Ø12.7	Ø12.7	Ø12.7	Ø12.7	Ø12.7	Ø12.7	Ø12.7	Ø15.88

If the main refrigerant pipe specified in the table is not available at the installation location, select the size given in brackets. In this case, prepare a suitable reducer.

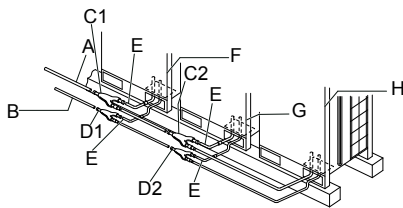
Main pipe	Alternative pipe and reducer	Main pipe	Alternative pipe and reducer
Ø9.53	(Ø9.53-Ø12.7)	Ø25.4	(Ø25.4-Ø28.6)
Ø12.7	(Ø12.7-Ø15.88)	Ø28.6	(Ø28.6-Ø31.75)
Ø15.88	(Ø15.88-Ø19.05)	Ø31.75	(Ø31.75-Ø34.9)
Ø19.05	(Ø19.05-Ø22.2)	Ø38.1	(Ø38.1-Ø41.3)
Ø22.2	(Ø22.2-Ø25.4)	–	–

### 9.7.4 Pipe connection kit (optional)

No.	Mode	Application in outdoor units		Model	Notes
		Outdoor unit	No. of outdoor units		
Pipe connection kit	Heat pump system	RAS-(20-24)FSXN	2	MC-20AN	For two pipes: • Gas: 1 part. • Liquid: 1 part.
		RAS-(26-36)FSXN	2	MC-21AN	
		RAS-(38-54)FSXN	3	MC-30AN	

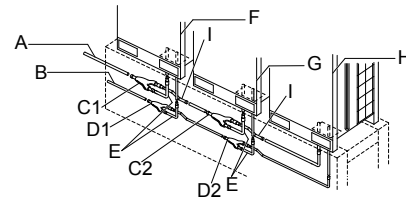
### 9.7.5 Example of installation (38 HP: 2 pipes)

Connection of front or rear pipes



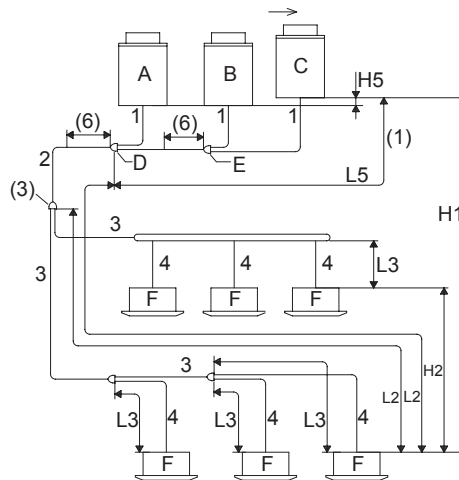
- A. Gas pipe (field-supplied).
- B. Liquid pipe (field-supplied).
- C1. Gas connection kit 1.
- C2. Gas connection kit 2.
- D1. Liquid connection kit 1.
- D2. Liquid connection kit 2.

Lower pipe connection



- E. Accessory for connection of pipes (L-shaped).
- F. Outdoor unit 1.
- G. Outdoor unit 2.
- H. Outdoor unit 3.
- I. Accessory for connection of pipes (Z-shaped).

### 9.7.6 Size of pipes (ø mm) and selection of multikit (2 pipes)



A: main outdoor unit    B, C: secondary outdoor units    D: connection kit 1    E: connection kit 2    F: indoor units

#### Size of pipes

1. Pipe diameter for the outdoor unit.
2. Diameter of the main pipe (from the base unit or connection kit 1 to the first branch)<sup>(2)</sup>.

HP outdoor unit	Equivalent pipe length < 100 m		HP outdoor unit	Equivalent pipe length < 100 m	
	Gas	Liquid		Gas	Liquid
8	Ø19.05	Ø9.53	(18-24)	Ø28.6	Ø15.88
10	Ø22.2	Ø9.53	(26-34)	Ø31.75	Ø19.05
(12/14)	Ø25.4	Ø12.7	(36-54)	Ø38.1	Ø19.05
16	Ø28.6	Ø12.7	—	—	—

3. Pipe diameter after first branch<sup>(3)</sup>.

Total HP indoor unit	Gas	Liquid	Total HP indoor unit	Gas	Liquid
< 6	Ø15.88	Ø9.53	(16-17.99)	Ø28.6	Ø12.7
(6-8.99)	Ø19.05	Ø9.53	(18-25.99)	Ø28.6	Ø15.88
(9-11.99)	Ø22.2	Ø9.53	(26-35.99)	Ø31.75	Ø19.05
(12-15.99)	Ø25.4	Ø12.7	> 36	Ø38.1	Ø19.05

4. Pipe diameter between multikit and indoor unit<sup>(4)</sup>.

HP indoor unit	Gas	Liquid	HP indoor unit	Gas	Liquid
(0.8-1.5)	Ø12.7	Ø6.35 <sup>(5)</sup>	8.0	Ø19.05	Ø9.53
2.0	Ø15.88	Ø6.35 <sup>(5)</sup>	10.0	Ø22.2	Ø9.53
(2.5-5.0)	Ø15.88	9.53	—	—	—

**Pipe working conditions**

No.		Make	Permitted pipe length <sup>(7)</sup>	
			≤ Recommended number of connected indoor units	≥ Recommended number of connected indoor units
Total pipe length		Current total liquid pipe length	≤ 1000 m <sup>(8)</sup>	≤ 300 m
Maximum pipe length	Current length	L1	≤ 165 m	≤ 165 m
	Equivalent length		≤ 190 m	≤ 190 m
Maximum pipe length between the multikit of the first branch and each indoor unit		L2	≤ 90 m	≤ 40 m
Maximum pipe length between each multikit and each indoor unit		L3	≤ 40 m	≤ 30 m
Pipe length between connection kit 1 and each outdoor unit		L5	≤ 10 m	≤ 10 m
Difference in height between outdoor and indoor units	Highest outdoor unit	H1	≤ 50 m	≤ 50 m
	Lowest outdoor unit		≤ 40 m	≤ 40 m
Difference in height between indoor units		H2	≤ 15 m	≤ 15 m
Difference in height between outdoor units		H5	≤ 0.1 m	≤ 0.1 m


**NOTE**

- <sup>(1)</sup> *The connection kit is taken into account from the side of the indoor unit (as connection kit 1).*
- <sup>(2)</sup> *When the maximum equivalent refrigerant pipe length (L1) from the outdoor unit/connection kit 1 to the indoor unit is greater than 100 m, the diameter of the gas/liquid pipe from the outdoor unit/connection kit 1 to the first branch must be increased using the reducer (field-supplied).*
- <sup>(3)</sup> *Where the refrigerant pipe length is greater than 100 m, the pipe diameter does not have to be increased after the first branch. Where the size of the multikit is greater than that of the first branch, adjust the size of the multikit to the first branch. Where the diameter of the pipe selected after the first branch is greater than the diameter of the pipe after it, use the same diameter as the inlet pipe.*
- <sup>(4)</sup> *The pipe diameter -4- must be the same as that of the indoor unit connection.*
- <sup>(5)</sup> *Where the liquid pipe length is greater than 15 m, use 9.53 mm diameter pipe and a reducer (field-supplied).*
- <sup>(6)</sup> *Keep a direct distance of 500 mm or greater after the connection kit.*
- <sup>(7)</sup> *The installation conditions for the refrigerant pipes are different depending on the number of indoor units connected.*
- <sup>(8)</sup> *The total pipe length permitted must be less than 1000 m due to the maximum additional refrigerant charge limitation.*


**NOTE**

- 1 *Check that the gas pipe and the liquid pipe are equivalent in terms of length and installation system.*
- 2 *Use the multikit system for branching of the indoor units and the CH unit.*
- 3 *Install the indoor unit and the multikit according to the instructions given in this manual.*
- 4 *Where the length of pipe L3 between each multikit and each indoor unit is considerably longer than on another indoor unit, the refrigerant will not flow correctly and performance is lower in comparison with other models (recommended pipe length: up to 15 m).*



**Pipe branching restrictions**

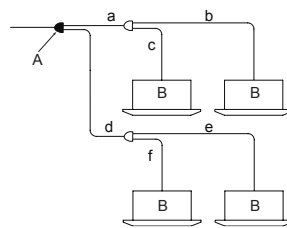
Follow the instructions given in the table below for pipe installation (field-supplied).

Maximum pipe length between the multikit of the first branch and each indoor unit (L2)	Main pipe branch <sup>(1)</sup>		Capacity ratio of the indoor units after the main branch	Branch and distributor combination
	Pipe length after the branch	Number of main pipe branches		
≤ 40 m	$a+b+c \leq 30$ m or $d+e+f \leq 30$ m	No limit	—	Available (Figures 3 and 4)
	$a+b+c > 30$ m or $d+e+f > 30$ m	Up to 2		
From 41 m to 90 m	—	Up to 1 (Figure 1)	≥ 40% (Figure 2)	Not available



**NOTE**

<sup>(1)</sup> Main pipe branch: distribution from one (1) multikit to two (2) multikits.

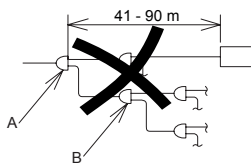


A: main branch

B: indoor units

Figure 1: two branches on the main pipe

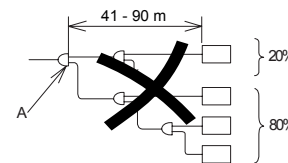
Figure 2: capacity ratio of the indoor units ≤ 40%



A: main branch

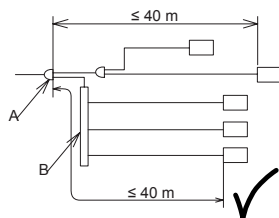
B: secondary branch

Figure 3: distributor used as branching for three pipes and branching for two pipes



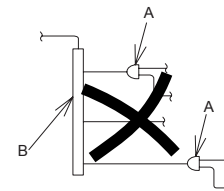
A: main branch

Figure 4: do not connect a branch to a distributor



A: branch

B: distributor

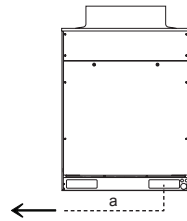


A: branch

B: distributor

## 9.8 Connection of refrigerant pipes for heat recovery (3 pipes)

### 9.8.1 Pipe sizes for RAS-(8-18)FSXN (Base unit)



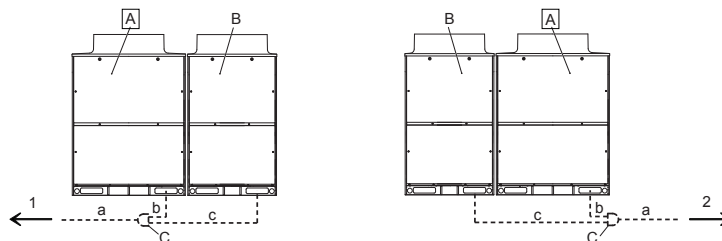
All measurements are in mm.

Model		RAS-8 FSXN	RAS-10 FSXN	RAS-12 FSXN	RAS-14 FSXN	RAS-16 FSXN	RAS-18 FSXN
a	Gas (low pressure)	Ø19.05	Ø22.2	Ø25.4	Ø25.4	Ø28.6	Ø28.6
	Gas (high pressure)	Ø15.88	Ø19.05	Ø22.2	Ø22.2	Ø22.2	Ø22.2
	Liquid	Ø9.53	Ø9.53	Ø12.7	Ø12.7	Ø12.7	Ø15.88

If the main refrigerant pipe specified in the table is not available at the installation location, select the size given in brackets. In this case, prepare a suitable reducer.

Main pipe	Alternative pipe and reducer	Main pipe	Alternative pipe and reducer
Ø9.53	(Ø9.53-Ø12.7)	Ø22.2	(Ø22.2-Ø25.4)
Ø12.7	(Ø12.7-Ø15.88)	Ø25.4	(Ø25.4-Ø28.6)
Ø15.88	(Ø15.88-Ø19.05)	Ø28.6	(Ø28.6-Ø31.75)
Ø19.05	(Ø19.05-Ø22.2)	-	-

### 9.8.2 Pipe sizes for RAS-(20-36)FSXN (Combination of two units)



A: main outdoor unit; B: secondary outdoor unit; C: connection kit; 1: indoor units on left side; 2: indoor units on right side.

Install the outdoor units and connect the refrigerant pipes as shown in the diagram. Please refer to the table to determine the appropriate connection kit and the diameter of the pipes for each unit

All measurements are in mm.

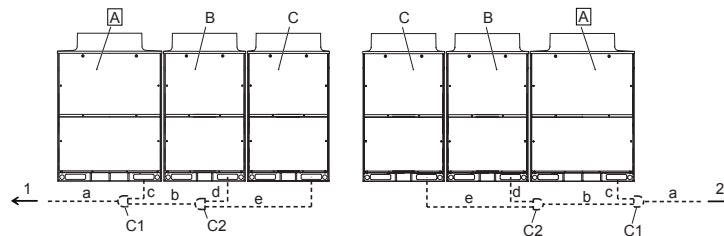
**Combination of base units**

Model	RAS-20 FSXN	RAS-22 FSXN	RAS-24 FSXN	RAS-26 FSXN	RAS-28 FSXN	RAS-30 FSXN	RAS-32 FSXN	RAS-34 FSXN	RAS-36 FSXN
Unit A	RAS-12 FSXN	RAS-14 FSXN	RAS-14 FSXN	RAS-14 FSXN	RAS-14 FSXN	RAS-16 FSXN	RAS-16 FSXN	RAS-18 FSXN	RAS-18 FSXN
Unit B	RAS-8 FSXN	RAS-8 FSXN	RAS-10 FSXN	RAS-12 FSXN	RAS-14 FSXN	RAS-14 FSXN	RAS-16 FSXN	RAS-16 FSXN	RAS-18 FSXN
Connection kit	MC-20XN				MC-21XN				
a	Gas (low pressure)	Ø28.6	Ø28.6	Ø28.6	Ø31.75	Ø31.75	Ø31.75	Ø31.75	Ø31.75
	Gas (high pressure)	Ø22.2	Ø25.4	Ø25.4	Ø25.4	Ø28.6	Ø28.6	Ø28.6	Ø28.6
	Liquid	Ø15.88	Ø15.88	Ø15.88	Ø19.05	Ø19.05	Ø19.05	Ø19.05	Ø19.05
b	Gas (low pressure)	Ø25.4	Ø25.4	Ø25.4	Ø25.4	Ø25.4	Ø28.6	Ø28.6	Ø28.6
	Gas (high pressure)	Ø22.2	Ø22.2	Ø22.2	Ø22.2	Ø22.2	Ø22.2	Ø22.2	Ø22.2
	Liquid	Ø12.7	Ø12.7	Ø12.7	Ø12.7	Ø12.7	Ø12.7	Ø12.7	Ø15.88
c	Gas (low pressure)	Ø19.05	Ø19.05	Ø22.2	Ø25.4	Ø25.4	Ø25.4	Ø28.6	Ø28.6
	Gas (high pressure)	Ø15.88	Ø15.88	Ø19.05	Ø22.2	Ø22.2	Ø22.2	Ø22.2	Ø22.2
	Liquid	Ø9.53	Ø9.53	Ø9.53	Ø12.7	Ø12.7	Ø12.7	Ø12.7	Ø15.88

If the main refrigerant pipe specified in the table is not available at the installation location, select the size given in brackets. In this case, prepare a suitable reducer.

Main pipe	Alternative pipe and reducer	Main pipe	Alternative pipe and reducer
Ø9.53	(Ø9.53-Ø12.7)	Ø22.2	(Ø22.2-Ø25.4)
Ø12.7	(Ø12.7-Ø15.88)	Ø25.4	(Ø25.4-Ø28.6)
Ø15.88	(Ø15.88-Ø19.05)	Ø28.6	(Ø28.6-Ø31.75)
Ø19.05	(Ø19.05-Ø22.2)	Ø31.75	(Ø31.75-Ø34.9)

**9.8.3 Pipe sizes for RAS-(38-54)FSXN (Combination of three units)**



A: main outdoor unit; B: secondary outdoor unit; C: secondary outdoor unit; C1: connection kit 1; C2: connection kit 2; 1: indoor units on left side; 2: indoor units on right side.

Install the outdoor units and connect the refrigerant pipes as shown in the diagram. Please refer to the table to determine the appropriate connection kit and the diameter of the pipes for each unit.

All measurements are in mm.

**Combination of base units**

Model	RAS-38 FSXN	RAS-40 FSXN	RAS-42 FSXN	RAS-44 FSXN	RAS-46 FSXN	RAS-48 FSXN	RAS-50 FSXN	RAS-52 FSXN	RAS-54 FSXN
Unit A	RAS-14 FSXN	RAS-16 FSXN	RAS-18 FSXN	RAS-18 FSXN	RAS-18 FSXN	RAS-18 FSXN	RAS-18 FSXN	RAS-18 FSXN	RAS-18 FSXN
Unit B	RAS-12 FSXN	RAS-12 FSXN	RAS-12 FSXN	RAS-14 FSXN	RAS-16 FSXN	RAS-18 FSXN	RAS-18 FSXN	RAS-18 FSXN	RAS-18 FSXN
Unit C	RAS-12 FSXN	RAS-12 FSXN	RAS-12 FSXN	RAS-12 FSXN	RAS-12 FSXN	RAS-12 FSXN	RAS-14 FSXN	RAS-16 FSXN	RAS-18 FSXN
Connection kit		MC-30XN							
a	Gas (low pressure)	Ø38.1	Ø38.1	Ø38.1	Ø38.1	Ø38.1	Ø38.1	Ø38.1	Ø38.1
	Gas (high pressure)	Ø31.75	Ø31.75	Ø31.75	Ø31.75	Ø31.75	Ø31.75	Ø31.75	Ø31.75
	Liquid	Ø19.05	Ø19.05	Ø19.05	Ø19.05	Ø19.05	Ø19.05	Ø19.05	Ø19.05
b	Gas (low pressure)	Ø28.6	Ø28.6	Ø28.6	Ø31.75	Ø31.75	Ø31.75	Ø31.75	Ø31.75
	Gas (high pressure)	Ø25.4	Ø25.4	Ø25.4	Ø28.6	Ø28.6	Ø28.6	Ø28.6	Ø28.6
	Liquid	Ø15.88	Ø15.88	Ø15.88	Ø19.05	Ø19.05	Ø19.05	Ø19.05	Ø19.05
c	Gas (low pressure)	Ø25.4	Ø28.6	Ø28.6	Ø28.6	Ø28.6	Ø28.6	Ø28.6	Ø28.6
	Gas (high pressure)	Ø22.2	Ø22.2	Ø22.2	Ø22.2	Ø22.2	Ø22.2	Ø22.2	Ø22.2
	Liquid	Ø12.7	Ø12.7	Ø15.88	Ø15.88	Ø15.88	Ø15.88	Ø15.88	Ø15.88
d	Gas (low pressure)	Ø25.4	Ø25.4	Ø25.4	Ø25.4	Ø28.6	Ø28.6	Ø28.6	Ø28.6
	Gas (high pressure)	Ø22.2	Ø22.2	Ø22.2	Ø22.2	Ø22.2	Ø22.2	Ø22.2	Ø22.2
	Liquid	Ø12.7	Ø12.7	Ø12.7	Ø12.7	Ø12.7	Ø15.88	Ø15.88	Ø15.88
e	Gas (low pressure)	Ø25.4	Ø25.4	Ø25.4	Ø25.4	Ø25.4	Ø25.4	Ø25.4	Ø28.6
	Gas (high pressure)	Ø22.2	Ø22.2	Ø22.2	Ø22.2	Ø22.2	Ø22.2	Ø22.2	Ø22.2
	Liquid	Ø12.7	Ø12.7	Ø12.7	Ø12.7	Ø12.7	Ø12.7	Ø12.7	Ø15.88

If the main refrigerant pipe specified in the table is not available at the installation location, select the size given in brackets. In this case, prepare a suitable reducer.

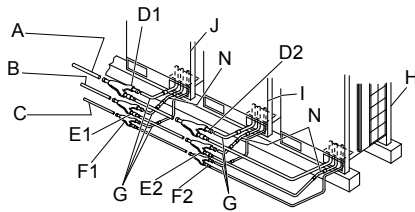
Main pipe	Alternative pipe and reducer	Main pipe	Alternative pipe and reducer
Ø9.53	(Ø9.53-Ø12.7)	Ø25.4	(Ø25.4-Ø28.6)
Ø12.7	(Ø12.7-Ø15.88)	Ø28.6	(Ø28.6-Ø31.75)
Ø15.88	(Ø15.88-Ø19.05)	Ø31.75	(Ø31.75-Ø34.9)
Ø19.05	(Ø19.05-Ø22.2)	Ø38.1	(Ø38.1-Ø41.3)
Ø22.2	(Ø22.2-Ø25.4)	-	-

**9.8.4 Pipe connection kit (optional)**

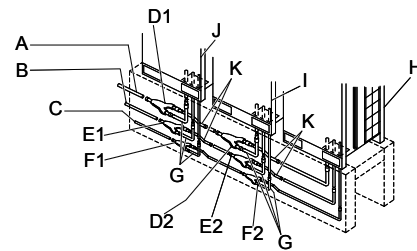
No.	Mode	Application in outdoor units		Model	Notes
		Outdoor unit	No. of outdoor units		
Pipe connection kit	Heat recovery system	RAS-(20-24)FSXN	2	MC-20XN	For three pipes: • Gas, high pressure: 1 part. • Gas, low pressure: 1 part. • Liquid: 1 part.
		RAS-(26-36)FSXN	2	MC-21XN	
		RAS-(38-54)FSXN	3	MC-30XN	

### 9.8.5 Example of installation (38 HP: 3 pipes)

Connection of front or rear pipes



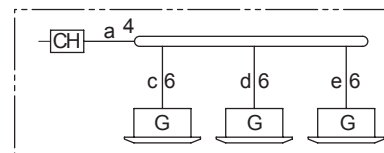
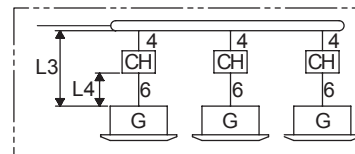
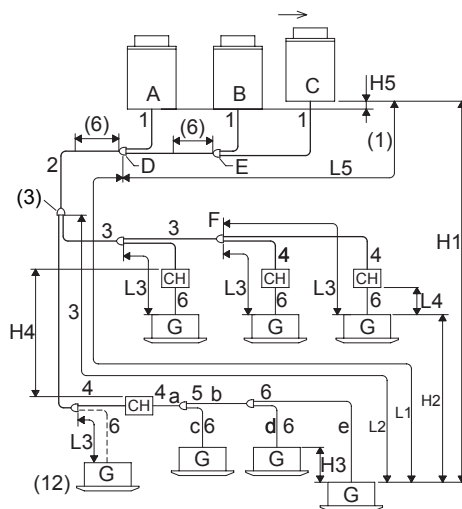
Lower pipe connection



- A. Gas pipe, low pressure (field-supplied).
- B. Gas pipe, high pressure (field-supplied).
- C. Liquid pipe (field-supplied).
- D1. Gas connection kit, low pressure 1.
- D2. Gas connection kit, low pressure 2.
- E1. Gas connection kit, high pressure 1.
- E2. Gas connection kit, high pressure 2.

- F1. Liquid connection kit 1.
- F2. Liquid connection kit 2.
- G. Accessory for connection of pipes (L-shaped).
- H. Outdoor unit 3.
- I. Outdoor unit 2.
- J. Outdoor unit 1.
- K. Accessory for connection of pipes (Z-shaped).
- N. Accessory for connection of pipes.

### 9.8.6 Size of pipes (ø mm) and selection of multikit (3 pipes)



A: main outdoor unit    B, C: secondary outdoor units    D: connection kit 1    E: connection kit 2    G: indoor units

3 pipes (high and low pressure gas, liquid)

2 pipes (gas, liquid)

2 pipes (low pressure gas, liquid)

#### Size of pipes

1. Pipe diameter for the outdoor unit.

2. Diameter of the main pipe (from the base unit or connection kit 1 to the first branch) (3 pipes)<sup>(2)</sup>.

HP outdoor unit	Gas, low pressure	Gas, high pressure	Liquid	HP outdoor unit	Gas, low pressure	Gas, high pressure	Liquid
8	Ø19.05	Ø15.88	Ø9.53	(22-24)	Ø28.6	Ø25.4	Ø15.88
10	Ø22.2	Ø19.05	Ø9.53	26	Ø31.75	Ø25.4	Ø19.05
(12/14)	Ø25.4	Ø22.2	Ø12.7	(28-36)	Ø31.75	Ø28.6	Ø19.05
16	Ø28.6	Ø22.2	Ø12.7	(36-54)	Ø38.1	Ø31.75	Ø19.05
(18/20)	Ø28.6	Ø22.2	Ø15.88	—	—	—	—

3. Pipe diameter after first branch (3 pipes)<sup>(3)</sup>.

Total HP indoor unit	Gas, low pressure	Gas, high pressure	Liquid	Total HP indoor unit	Gas, low pressure	Gas, high pressure	Liquid
< 6	Ø15.88	Ø12.7	Ø9.53	(18-21.99)	Ø28.6	Ø22.2	Ø15.88
(6-8.99)	Ø19.05	Ø15.88	Ø9.53	(22-25.99)	Ø28.6	Ø25.4	Ø15.88
(9-11.99)	Ø22.2	Ø19.05	Ø9.53	(26-35.99)	Ø31.75	Ø28.6	Ø19.05
(12-15.99)	Ø25.4	Ø22.2	Ø12.7	> 36	Ø38.1	Ø31.75	Ø19.05
(16-17.99)	Ø28.6	Ø22.2	Ø12.7	—	—	—	—

4. Pipe diameter between the CH unit and the multikit (3 pipes and 2 pipes)<sup>(9)</sup>.

CH unit	Maximum combination of indoor units <sup>(8)</sup>	Capacity of indoor units	3 pipes		2 pipes	
			Gas, low pressure	Gas, high pressure	Gas	Liquid
CH-6.0N1	7	(0.8-1.5)	Ø15.88	Ø12.7	Ø12.7 <sup>(15)</sup>	Ø9.53
		(1.6-4.0)	Ø15.88	Ø12.7	Ø15.88	Ø9.53
		(4.1-6.0)	Ø19.05	Ø15.88	Ø15.88	Ø9.53
CH-10.0N1	8	(6.1-8.0)	Ø19.05	Ø15.88	Ø19.05	Ø9.53
		(8.1-10.0)	Ø22.2	Ø19.05	Ø22.2	Ø9.53

## 5. Pipe diameter for 2 pipes and multikit.

Total HP indoor unit	Gas	Liquid	Total HP indoor unit	Gas	Liquid
< 6	Ø15.88	Ø9.53	(12-15.99)	Ø25.4	Ø12.7
(6-8.99)	Ø19.05	Ø9.53	(16-17.99)	Ø28.6	Ø12.7
(9-11.99)	Ø22.2	Ø9.53	(18-25.99)	Ø28.6	Ø15.88

6. Pipe diameter between multikit and indoor unit<sup>(4)</sup>.

HP indoor unit	Gas	Liquid	HP indoor unit	Gas	Liquid
(0.8-1.5)	Ø12.7	Ø6.35 <sup>(5)</sup>	8.0	Ø19.05	Ø9.53
2.0	Ø15.88	Ø6.35 <sup>(5)</sup>	10.0	Ø22.2	Ø9.53
(2.5-5.0)	Ø15.88	9.53	—	—	—

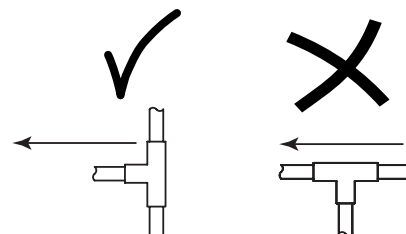
**Pipe working conditions**

No.	Make	Permitted pipe length <sup>(13)</sup>	
		≤ Recommended number of connected indoor units	≥ Recommended number of connected indoor units
Total pipe length	Current total liquid pipe length	≤ 1000 m <sup>(14)</sup>	≤ 300 m
Maximum pipe length	Current length	≤ 165 m	≤ 165 m
	Equivalent length	≤ 190 m	≤ 190 m
Maximum pipe length between the multikit of the first branch and each indoor unit	L2	≤ 90 m	≤ 40 m
Maximum pipe length between each multikit and each indoor unit	L3	≤ 40 m	≤ 30 m
Total pipe length between the CH unit and each indoor unit	*L4 *a+b+c+d+e	CH-6.0N1: ≤ 30 m	CH-6.0N1: ≤ 30 m
		CH-10.0N1: ≤ 10 m	CH-10.0N1: ≤ 10 m
Pipe length between connection kit 1 and each outdoor unit	L5	≤ 10 m	≤ 10 m
Difference in height between outdoor and indoor units	Highest outdoor unit	≤ 50 m	≤ 50 m
	Lowest outdoor unit	≤ 40 m	≤ 40 m
Difference in height between indoor units	H2	≤ 15 m	≤ 15 m
Difference in height between indoor units using the same CH unit	H3	≤ 4 m	≤ 4 m
Difference in height between CH units	H4	≤ 15 m	≤ 15 m
Difference in height between outdoor units	H5	≤ 0.1 m	≤ 0.1 m



**NOTE**

- *(1) The connection kit is taken into account from the side of the indoor unit (as connection kit 1).*
- *(2) When the maximum equivalent refrigerant pipe length (L1) from the outdoor unit/connection kit 1 to the indoor unit is greater than 100 m, the diameter of the liquid pipe from the outdoor unit/connection kit 1 to the first branch must be increased using the reducer (field-supplied).*
- *(3) Where the refrigerant pipe length is greater than 100 m, the pipe diameter does not have to be increased after the first branch. Where the size of the multikit is greater than that of the first branch, adjust the size of the multikit to the first branch. Where the diameter of the pipe selected after the first branch is greater than the diameter of the pipe after it, use the same diameter as the inlet pipe.*
- *(4) The pipe diameter -6- must be the same as that of the indoor unit connection.*
- *(5) Where the liquid pipe length is greater than 15 m, use 9.53 mm diameter pipe and a reducer (field-supplied).*
- *(6) Keep a direct distance of 500 mm or greater after the connection kit.*
- *(7) In the case of branches, where the pipe length between the three-pipe branch -F- and the furthest indoor unit exceeds 5 m, use a T-branch pipe for the three-branch liquid pipe (corresponding to the same diameter, as per JIS B8607).*
- *(8) Where the number of connectable indoor units is greater than four, the high/low-pressure gas, gas and liquid pipes,*



**-4-, -5- and -6-, must be increased by one measurement, respectively.**

- (9) **The liquid pipe does not have to be connected to the CH unit. See Table 6 for the pipe diameter between the multikit and the indoor unit.**
- (10) **Where the combination of indoor unit capacities is 10 HP for the CH-10.0N1 unit, performance will drop by approximately 5% in refrigeration and 10% in heating.**
- (11) **The excess total capacity may lead to insufficient performance and abnormal operating noise. Check that the installation is within the total capacity values.**
- (12) **For operations in refrigeration mode only, connect the indoor units using gas and liquid pipes (without the CH unit). The total capacity in refrigeration mode only must be less than 50% the total capacity of the indoor units.**
- (13) **The installation conditions for the refrigerant pipes are different depending on the number of indoor units connected.**
- (14) **The total pipe length permitted must be less than 1000 m due to the maximum additional refrigerant charge limitation.**
- (15) **Where the branch is after the CH unit and the capacity of the connected indoor unit is (0.8-1.5) HP, use a 15.88 mm diameter for the gas pipe.**



**NOTE**

- 1 **Check that the gas pipe and the liquid pipe are equivalent in terms of length and installation system.**
- 2 **Use the multikit system for branching of the indoor units and the CH unit.**
- 3 **Install the indoor unit, the multikit and the CH unit according to the instructions given in this manual.**
- 4 **Where the length of pipe L3 between each multikit and each indoor unit is considerably longer than on another indoor unit, the refrigerant will not flow correctly and performance is lower in comparison with other models (recommended pipe length: up to 15 m).**

**Pipe branching restrictions**

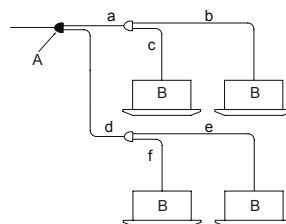
Follow the instructions given in the table below for pipe installation (field-supplied).

Maximum pipe length between the multikit of the first branch and each indoor unit (L2)	Main pipe branch <sup>(1)</sup>		Capacity ratio of the indoor units after the main branch	Branch and distributor combination
	Pipe length after the branch	Number of main pipe branches		
≤ 40 m	a+b+c ≤ 30 m or d+e+f ≤ 30 m	No limit	—	Available (Figures 3 and 4)
	a+b+c > 30 m or d+e+f > 30 m	Up to 2		
From 41 m to 90 m	—	Up to 1 (Figure 1)	≥ 40% (Figure 2)	Not available



**NOTE**

<sup>(1)</sup> **Main pipe branch: distribution from one (1) multikit to two (2) multikits.**

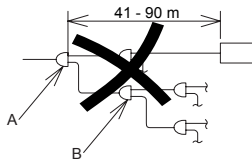


A: main branch

B: indoor units

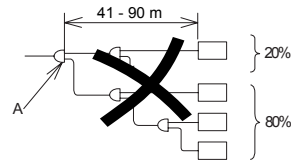


Figure 1: two branches on the main pipe



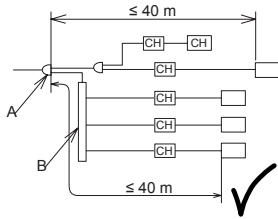
A: main branch  
B: secondary branch

Figure 2: capacity ratio of the indoor units  $\leq 40\%$



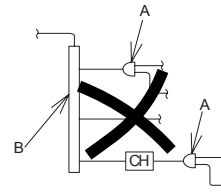
B: secondary branch

Figure 3: distributor used as branching for three pipes and branching for two pipes



A: branch  
B: distributor

Figure 4: do not connect a branch to a distributor



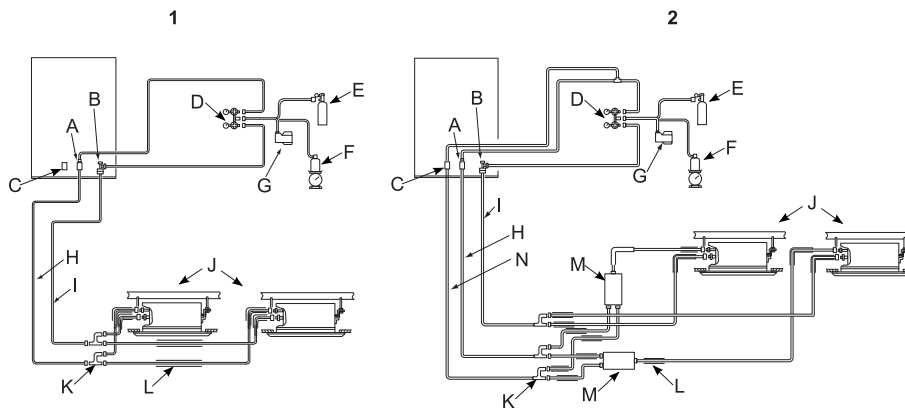
A: branch  
B: distributor

## 9.9 Refrigerant charge

### 9.9.1 Installation airtight test

Check that the outdoor and indoor units are connected via the field-supplied refrigerant pipes.

Check the suspension of the refrigerant pipes as described in chapter [Refrigerant pipe suspension](#), see on page 0 .



1. Heat pump system.

2. Heat recovery system.

A. Stop valve, high pressure (gas).

B. Stop valve (liquid).

C. Stop valve, low pressure (gas).

D. Measurement indicators.

E. Nitrogen gas bottle.

F. Refrigerant bottle and balance.

G. Vacuum pump.

H. Refrigerant gas pipe, high pressure.

I. Refrigerant liquid pipe

J. Indoor units.

K. Multikit.

L. Insulation.

M. CH unit.

N. Refrigerant gas pipe, low pressure.

Check the seal of the welds and flared connections. To do so, connect the measurement indicators on the check joints of the stop valves and on one vacuum pump or nitrogen gas bottle, using the flexible charge pipes of the indicators.



#### NOTE

- **Only tools and indicators specifically for use with R410A refrigerant gas should be used.**
- **Do not open the stop valves on the outdoor unit.**



#### DANGER

**Only use nitrogen gas when testing for leaks. Never use oxygen, acetylene or fluorocarbon gas; these could result in an intoxication or explosion.**

Apply a maximum pressure of 4.15 MPa of nitrogen gas to the installation.

Check there are no refrigerant leaks in the welds and the flared connections of all the system. To do so, use a gas leak sensor or a soap and water solution.

If any leaks are found in the installation, repair and repeat the airtight test.

### 9.9.2 Installation vacuum

Connect the measurement indicators on the check joints of the stop valves.



#### NOTE

**Only tools and indicators specifically for use with R410A refrigerant gas should be used.**

Vacuum the installation to a maximum pressure of -0.1 MPa (-756 mmHg) or lower.

On completion of the vacuum, close the indicator valve and switch off the vacuum pump.

Check that the pressure reading on the indicators remains stable for an hour or more. If this is not the case, check there are no refrigerant leaks at the welds and the flared connections of all the system.



#### NOTE

**If the maximum pressure of -0.1 MPa (-756 mmHg) or less is not obtained, and there are no leaks, keep the vacuum pump running for one or two hours.**

If any leaks are found in the installation, repair and repeat the airtight test.

Replace the stop valve covers and tighten to the corresponding torque.

### 9.9.3 Quantity of refrigerant charged in the W0 outdoor unit

Outdoor unit	Quantity of refrigerant charged in the W0 outdoor unit (kg)	Outdoor unit	Quantity of refrigerant charged in the W0 outdoor unit (kg)
RAS-8FSXN	6.5	RAS-14FSXN	9.0
RAS-10FSXN	6.5	RAS-16FSXN	9.0
RAS-12FSXN	7.0	RAS-18FSXN	10.5



#### NOTE

**For combinations of two or three outdoor units, the quantity of refrigerant corresponds to the sum of the refrigerant charged in each of the units.**

### 9.9.4 Maximum additional refrigerant charge

The total additional charge must not exceed the maximum additional refrigerant charge indicated in the following table.

Outdoor unit	Maximum additional refrigerant charge (kg)	Outdoor unit	Maximum additional refrigerant charge (kg)
RAS-(8/10)FSXN	28	RAS-(18-24)FSXN	51
RAS-12FSXN	36	RAS-(26-54)FSXN	63
RAS-(14/16)FSXN	40	—	—

### 9.9.5 Method of calculation of the total additional refrigerant charge

Although the outdoor unit is supplied charged with refrigerant, it is necessary to add a certain additional amount depending upon the length of the refrigerant pipes and the capacity ratio of the indoor units.

The different factors determining the total additional refrigerant charge (W4) in the system are given as W0, W1 and W2.

The additional quantity of refrigerant is calculated using the following method.

**W0: additional refrigerant charge according to the length of the refrigerant liquid pipes.**

Nominal diameter		Total length (m)	Quantity of refrigerant per metre of pipe	Additional refrigerant charge (kg)
mm	Inches			
6.35	1/4	___ m	x 0.39	
9.53	3/8	___ m	x 0.28	
12.7	1/2	___ m	x 0.19	
15.88	5/8	___ m	x 0.12	
19.05	3/4	___ m	x 0.06	
22.2	7/8	___ m	x 0.03	
Total additional refrigerant charge =				_____ kg

**W1: additional refrigerant charge per indoor unit**

No of indoor units of 8 and 10 HP	Amount of refrigerant per unit	Additional refrigerant charge (kg)
	x 1.0 kg/unit	_____ kg


**NOTE**

*It is not necessary to increase the additional refrigerant charge for indoor units with less than 8 HP.*

**W3: Additional refrigerant charge according to the connection capacity ratio of indoor units**

Connection capacity ratio of indoor units = total capacity of indoor units / total capacity of outdoor unit

Ratio of indoor units	Additional refrigerant charge (kg)
< 100%	0 kg
(100–115) %	0.5 kg
(116–130) %	1.0 kg

**W4: total additional refrigerant charge**

$$\text{Total additional refrigerant charge (kg)} = W1 + W2 + W3$$


**NOTE**

*Check that the total additional refrigerant charge is not greater than the values given in: **Maximum additional refrigerant charge**, see on page 219.*

**9.9.6 Refrigerant charge**

Once the installation has been emptied, check that the stop valves are fully closed. To do so, remove the caps and check that they are closed with the corresponding torque.

Charge the total additional refrigerant as calculated in chapter: *Method of calculation of the total additional refrigerant charge*, see on page 219.

If it is not possible to charge the total quantity of additional refrigerant, proceed as follows:

Fully open the gas stop valve (in the case of the outdoor units of heat recovery systems, open the high and low pressure gas valves).

Start the system running in cooling mode and open the liquid outlet valve of the measurement indicators connected to the check joints of the stop valves.

Slightly open the liquid stop valve (tolerance of quantity of total additional refrigerant: 0.5 kg).

When all the refrigerant has been charged, fully open the liquid stop valve.

**CAUTION**

- **Only charge the quantity of additional refrigerant as calculated in chapter [Method of calculation of the total additional refrigerant charge](#), see on page 219. Too low or too high a charge could cause damage to the compressor.**
- **The refrigerant should be charged through the liquid stop valve. If the refrigerant is charged through the gas stop valves, the compressor will be damaged.**

Fill in the F-Gas Label.

**9.9.7 Automatic system to estimate the amount of refrigerant charged in the unit**

Fit all covers and lids on the unit, except for the electrical box and service covers.

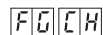
Connect the power supply to the indoor and outdoor units in the same refrigeration cycle for the function to automatically estimate the amount of refrigerant charged in the unit.

**NOTE**

- ***This function is applicable when the outdoor temperature margin ranges from 0 to 43 °C DB (DB: dry bulb) and the indoor temperature from 10 to 32 °C DB (DB: dry bulb).***
- ***For RAS-(20-54)FSXN units, the indications, verifications and consultations of the seven-segment display should be done on the main unit.***
- ***The electricity supply to the outdoor unit must remain connected twelve hours prior to the test to heat up the compressor oil.***

Turn the DSW5 contact number four (on PCB1) to ON.

The seven-segment display on the unit will indicate:



Check the seven-segment display and press PSW1. The outdoor unit fan and the compressor will start up. The display will indicate:

The function to automatically estimate the amount of refrigerant charged in the unit takes between 30 and 40 minutes to make the necessary checks.

Check the result obtained with the following table:

Display indication	Result	Indications
	Sufficient charge	The refrigerant charge is sufficient. Turn the DSW5 contact number four (on PCB1) to OFF and carry out the test run.
	Excessive charge	The refrigerant charge is excessive. Calculate the refrigerant charge according to the length of the refrigerant pipes. Collect the charged refrigerant appropriately and charge the unit with correct amount of refrigerant.
	Insufficient charge	The refrigerant charge is insufficient. Check whether the unit has been charged with additional refrigerant. Calculate the refrigerant charge according to the length of the refrigerant pipes. Charge the unit with the correct amount of refrigerant.
	Abnormal completion	Locate the cause of the abnormal completion in line with the instructions below. Once the cause of the abnormal completion has been solved, restart the check. 1. Is the DSW5 contact number four (on PCB1) turned to ON before the power supply is connected? 2. Are all indoor units ready and waiting before DSW5 contact number four (on PCB1) is turned to ON? 3. Is the outdoor ambient temperature within the working ranges established (0 – 43 °C)? (In some cases, when the number of indoor units connected exceeds the maximum number recommended and the outdoor temperature is above 35 °C, the check cannot be made). 4. Is the total operating capacity ratio of the indoor units 30% or less? 5. Is DSW4 contact number four (forced compressor stoppage) turned to OFF?

Turn the DSW5 contact number four (on PCB1) to OFF when the refrigerant charge is sufficient. Wait at least three minutes before turning the DSW5 contact number four (on PCB1) to ON so that the outdoor unit is ready to start operating.



#### NOTE

- **During the check, the seven-segment display may change to the protection control code due to the protection control being activated, although this is quite normal.**
- **Consult the information on the inside of the unit service cover for further information on the protection control code.**



#### CAUTION

- **Releasing refrigerant into the atmosphere is forbidden.**
- **Where the amount of refrigerant charged in the system is to be corrected, it must be collected appropriately.**
- **Follow the instructions given on the specific label attached to the unit with regards to the refrigerant.**
- **Fill in the F-Gas Label.**

## 9.10 Precautions in the event of refrigerant leaks

---



### DANGER

*Fitters and the designers of the installations must strictly observe local and national legislation, and local codes regarding safety requirements in the event of refrigerant leaks.*

### 9.10.1 Maximum permitted concentration of hydrofluorocarbon (HFC)

The R410A refrigerant gas, used in the equipment, is fireproof and not toxic.



### DANGER

*In the event of a leak, the gas will spread around the room, displacing the air, and could therefore result in asphyxia.*

The maximum permitted concentration of HFC R410A gas in the air is 0.44 kg/m<sup>3</sup>, in accordance with standard EN378-1. Therefore, efficient measures should be adopted to ensure the concentration of R410A gas in the air is kept below 0.44 kg/m<sup>3</sup> in the event of a leak.

### 9.10.2 Calculation of the refrigerant concentration

- 1 Calculate the total quantity of refrigerant  $R$  (kg) charged in the system; to do so, connect all the indoor units of the rooms in which you wish to have air conditioning.
- 2 Calculate the volume  $V$  (m<sup>3</sup>) of each room.
- 3 Calculate the refrigerant concentration  $C$  (kg/m<sup>3</sup>) of the room in accordance with the following formula:

$$R / V = C$$

$R$ : Total quantity of refrigerant charged (kg).

$V$ : volume of the room (m<sup>3</sup>).

$C$ : concentration of refrigerant (= 0.44 kg/m<sup>3</sup> for R410A gas).

### 9.10.3 Countermeasures in the event of refrigerant leaks

The room should have the following characteristics in case of a leak of refrigerant:

- 1 Opening without shutter to permit the circulation of fresh air in the room.
- 2 Opening without door measuring 0.15%, or greater, of the floor surface.
- 3 A fan with a capacity of at least 0.4 m<sup>3</sup>/minute per tonne of Japanese refrigeration (= volume displaced by the compressor / 5.7 m<sup>3</sup>/h) or greater, connected to a gas sensor in the air conditioning system which uses the refrigerant.

Model	Tons	Model	Tons
RAS-8FSXN	4.11	RAS-32FSXN	12.16
RAS-10FSXN	4.11	RAS-34FSXN	12.59
RAS-12FSXN	4.11	RAS-36FSXN	13.02
RAS-14FSXN	6.08	RAS-38FSXN	14.30
RAS-16FSXN	6.08	RAS-40FSXN	14.30
RAS-18FSXN	6.51	RAS-42FSXN	14.73
RAS-20FSXN	8.22	RAS-44FSXN	16.70
RAS-22FSXN	10.19	RAS-46FSXN	16.70
RAS-24FSXN	10.19	RAS-48FSXN	17.13
RAS-26FSXN	10.19	RAS-50FSXN	19.10
RAS-28FSXN	12.16	RAS-52FSXN	19.10
RAS-30FSXN	12.16	RAS-54FSXN	19.53



#### **DANGER**

***Special attention should be given to areas where the refrigerant may be deposited and stay in the room, such as basements or similar, as it is heavier than air.***



# 10. Electrical wiring

## Index

10.1	General information.....	226
10.2	General verifications.....	227
10.3	Setting of the DSW switches on PCB1.....	228
10.4	Shared wiring between outdoor and indoor units.....	231
10.4.1	Connection of outdoor units.....	231
10.4.2	Connection of indoor units.....	232
10.4.2.1	Connection diagram: heat pump system.....	234
10.4.2.2	Connection diagram: heat recovery system.....	235
10.5	Connection of the power supply circuits.....	236
10.5.1	Cable sizes.....	236
10.5.2	Main breaker switch.....	236

## 10.1 General information

---



### CAUTION

- *Before any work to the electrical wiring or regular inspections, switch off the mains power supply of the indoor and outdoor units. Wait three minutes before starting installation or maintenance work.*
- *Make sure that the indoor and outdoor fans have come to a complete standstill before starting work on the electrical wiring or regular inspections.*
- *Protect cables, the drainage pipe, electrical components, etc. from rodents and insects; otherwise these might damage unprotected components and this could result in fire.*
- *Do not allow cables to come into contact with the refrigerant pipes, metal edges, printed circuit boards (PCB) or the electric components inside the unit; the cables may be damaged and this could result in fire.*
- *Firmly secure the cables inside the indoor unit with plastic flanges.*
- *Before starting work on the installation of the outdoor unit, place the DSW7 in the correct position according to the expected supply voltage: [Setting of the DSW switches on PCB1](#), see on page 228.*



### DANGER

- *Use an earth leakage breaker with medium sensitivity, and an activation speed of 0.1 or less. If this is not fitted, there is a risk of electric shock and/or fire.*
- *Install an earth leakage breaker, fuse and circuit breaker for each outdoor unit power line. Not fitting it may cause an electric shock or fire.*

## 10.2 General verifications

- 1 Make sure the field-supplied electric components (main power switches, circuit breakers, wires, connectors and connection terminals) have been selected correctly in line with the electrical data given.
  - a The electricity supply to the unit should be via an exclusive power control switch and protective circuit breaker, certified and installed in accordance with local or national safety regulations.
  - b The electricity supply for the outdoor and indoor units should be separate. Connect the voltage supply wiring for each group of indoor units to the same outdoor unit (maximum capacity for each group of indoor units: 26 HP).
  - c For heat recovery systems, the CH unit and the indoor unit of the same refrigerant cycle can be supplied from the same mains power switch.
- 2 Check that the supply voltage is between 90 and 110% of the rated voltage. Where the voltage capacity is too low, it will not be possible to start the system due to the drop in voltage.
- 3 Sometimes, the refrigeration/heating system is not able to operate correctly in the following cases:
  - When the system is supplied from the same supply line as other major consumers (heavy machinery, power inverter systems, cranes, welding machinery, etc).
  - When the supply cables of the major consumers and the refrigeration/heating system are very close together.

In these cases, induction in the wiring to the refrigeration/heating system may arise due to a rapid change in the electricity consumption of the above consumers and their start-up. Therefore before starting installation work, check the regulations and standards concerning adequate protection of the power supply line.



### NOTE

***For further information, please refer to the applicable legislation in the country in which the unit is to be fitted.***

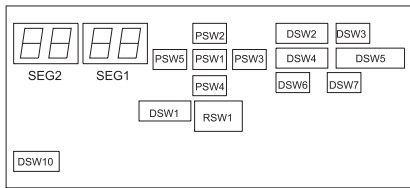
- 4 During the preliminary preparation work of the electricity supply line for the unit, the provisions in local and national legislation must never be violated.
- 5 Check that the earth cable is correctly connected.



### DANGER

- ***Never connect the earth cable to the refrigerant pipes. The gas in the pipes could cause a fire.***
- ***Do not connect the earth cable to the lighting rod. The electrical potential of earth would increase abnormally.***

### 10.3 Setting of the DSW switches on PCB1



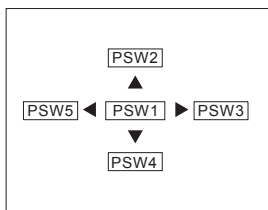
Location of the DSW switches on PCB1.

#### CAUTION

Before changing the settings of the DIP switches, the voltage supply should be disconnected. Otherwise, the new settings will not be valid.

#### NOTE

- Only the DIP DSW1, DSW2 and DSW4 switches can be set while the voltage supply is connected.
- The symbol “■” indicates the position of the DIP switches. The figures show the position of the DIP switch once the position setting has been completed.
- With the DSW4 switch, the unit starts or stops after 10 to 20 sec. of the switch being activated.
- Record the number of the outdoor unit to tell it apart from others during service and maintenance operations in this area:



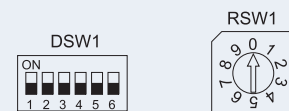
PSW buttons on PCB1

PSW1: accept.

PSW2, 3, 4 and 5: for checking.

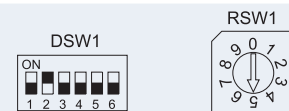
#### DSW1, RSW1: refrigerant cycle number setting

- Setting required.
- Setting before RSW1 supply: 0.
- Setting before DSW1 supply: 0 (digit of tens).
- Set each outdoor unit number on each refrigerant cycle.
- Outdoor and indoor units belonging to the same refrigerant cycle: setting the same cycle number in the outdoor and indoor units (indoor units: DSW5 and RSW2).



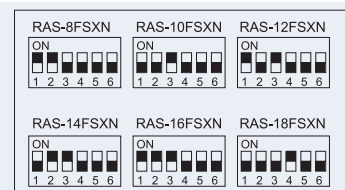
#### DSW1, RSW1: setting example for refrigerant cycle number 25

- maximum refrigerant cycle number setting: 63.



#### DSW2: capacity setting

Setting not required.



**DSW3**

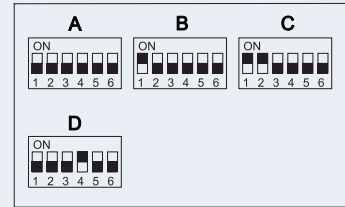
Setting not required.



**DSW4: test run and service settings**

Setting required.

- A: setting before supply:
- B: refrigeration test run.
- C: heating test run.
- D: forced stoppage of the compressor.



**DSW5: emergency operation /test run and service setting**

Setting not required. Activate only when the following functions are used:

- Contact 1: except No 1, compressor operation.
- Contact 2: except No 2, compressor operation.
- Contact 4: Monitoring of refrigerant quantity.



**DSW6: setting outdoor unit number**

Setting required.

- 1: setting before supply:

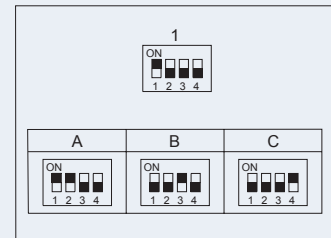


**NOTE**

*This combination of outdoor units must be set.*

Setting for combination of units:

- A: unit 1 (main).
- B: unit 2.
- C: unit 3.



**DSW7: supply voltage setting**

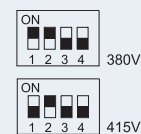
Setting required.

- Setting before supply: 380 V.



**NOTE**

*This setting is necessary in outdoor units supplied with 400 V.*



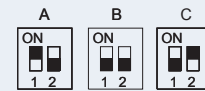
**DSW10: communication setting**

Setting required.

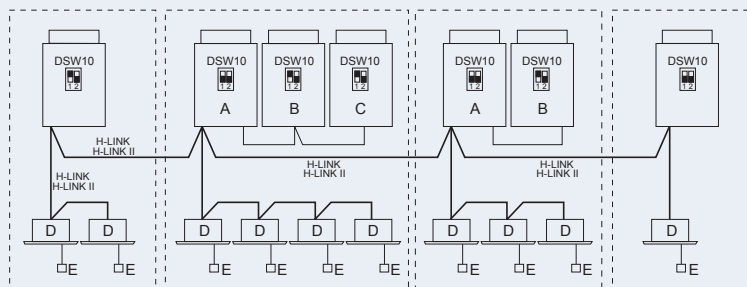
- A: setting before supply:
- B: cancellation of final resistance.


**NOTE**

- C: If the communication circuit fuse has opened, the PCB1 board can only be recovered by activating contact 2.


**NOTE**

- Where two or more outdoor units are installed and connected using the H-LINK bus, DSW10 contact 1 on the master or main unit must be set to OFF from the second unit.
- Where just one unit is installed, this setting is not required.

**DSW10: switch setting example**


A. Main unit.

B. Secondary unit.

C. Secondary unit.

D. Indoor units.

E. Remote control.

## 10.4 Shared wiring between outdoor and indoor units

### CAUTION

- *Connecting the operating line cables incorrectly may lead to faults in the PCB.*
- *Protect wires, drain pipe and electric parts, etc. from rodents and insects, as they could bite unprotected parts and even cause a fire.*
- *Prevent the cables from touching the gas refrigerant pipes, metal edges, printed circuit board (PCB) edges or electrical parts inside the unit. Otherwise the cables could be damaged and, in a worst case scenario, lead to a fire.*
- *Firmly secure the cables inside the indoor unit with plastic flanges.*

### General instructions to bear in mind when connecting the shared wiring between the outdoor and indoor units

- 1 Local or national regulations must be followed at all times during the preliminary work to prepare the communication line between units.

### NOTE

*For further information, please refer to the applicable legislation in the country in which the unit is to be fitted.*

- 2 The units are installed grouped together for each planned refrigerant cycle. As a result, the refrigerant pipes and the control wiring are connected grouped to the units belonging to the same refrigerant cycle.
- 3 Use a shielded twisted pair cable or shielded pair cable with a cross-section of over 0.75 mm<sup>2</sup> (equivalent to KPEV-S) for communications between the outdoor and the indoor unit and between the indoor units.
- 4 Always use a 2-core cable for the operating line. Never use a cable with more than three cores.
- 5 Use shielded cable for intermediate wiring on lengths of less than 300 m to protect the units from electrical noise and electromagnetic interference. The size of the cable must be in line with national and local regulations.
- 6 Make a hole close the power cable connection opening when connecting several outdoor units from one power line.
- 7 Make sure the electric components supplied by the fitter (main power switches, circuit breakers, wires, connectors and connection terminals) have been selected correctly in line with the electrical data given in this manual.

### NOTE

*Secure the rubber bushes with adhesive when the outdoor unit ducts are not used.*

#### 10.4.1 Connection of outdoor units

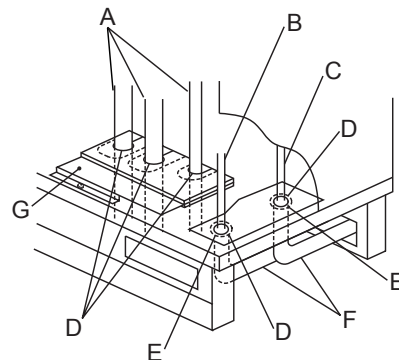
Remove cover -G- to the refrigerant pipes -A-.

The power -C- and communication -B- cables should be inserted in the unit through the pre-drilled holes and lower rubber bushing -E- provided, using a different protective duct -F- for each one.

### NOTE

*Do not insert the supply and communication cables together through the same protective duct. Keep a minimum distance between them of 50 mm.*

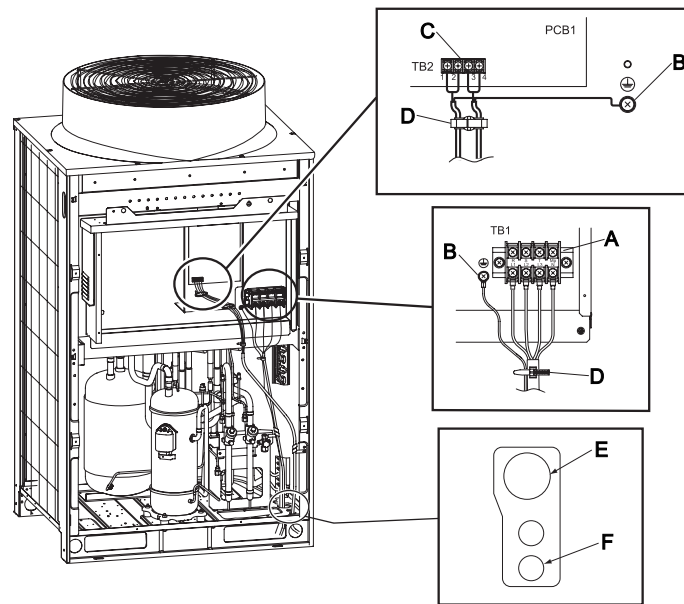
Fit the cover on the pipes -G- and completely seal access -D- of the pipes to the unit, to prevent the entrance of water, rodents and dirt.



Do not allow the cables to touch the refrigerant pipes, sharp metal edges or electrical components from inside the unit.


**NOTE**

- **Fasten the power cables with the flanges provided inside the unit.**
- **Attach unused rubber bushings with adhesive.**
- **Make a drainage hole in the lowest part of the protective duct.**



Connect the three-phase power cables on terminals L1, L2, L3 and N of the TB1 -A- terminal board and connect the earth cable to the screw-in terminal -B-. Use insulated terminals or heat-shrink covers.

Connect the communication cables on the terminals on the TB2 box -C- of the PCB1 circuit board -D-:

- From the indoor units to the outdoor unit: terminals 1 and 2.
- From the outdoor unit to the next outdoor unit in the same refrigerant cycle: terminals 3 and 4.

E:  $\varnothing$ 53 mm pre-drilled hole for power cables.

F:  $\varnothing$ 26 mm pre-drilled hole for communication cables.


**NOTE**

**Completely seal the entrance to the duct using sealant, etc. to prevent water from entering it.**

Tighten the connection terminals as shown in the following table:

Size	Tightening torque (Nm)
M4	(1.0–1.3)
M5	(2.0–2.4)
M6	(4.0–5.0)
M8	(9.0–11.0)
M10	(18.0–23.0)

### 10.4.2 Connection of indoor units

Connect each outdoor unit to a power supply line. Install an earth leakage breaker, fuse and circuit breaker for each outdoor unit power line.



Connect each group of indoor units corresponding to an outdoor unit to a voltage supply line (maximum capacity for each group of indoor units: 26 HP). Install an earth leakage breaker, fuse and circuit breaker for each group of indoor units.

Connect the communication cable between the indoor units, the CH units and the outdoor units.

Connect the communication cable on the corresponding units to the same refrigerant cycle. (Where the refrigerant pipe of the indoor unit is connected to the outdoor unit, connect the communication cable to the same indoor unit).


**NOTE**

**Connecting the refrigerant pipe and the communication cable to units in different refrigeration cycles may lead to operating problems.**

Use shielded twisted pair cable or shielded pair cable. Do not use cable with three or more conductors.

Use the same type of cables for the H-LINK system of units in each refrigerant cycle.

Ensure a minimum distance of 50 mm between the power cables and the communication cables and 1500 mm between these and the power cables of other electrical devices. Where this is not possible, install power cables in a metal duct separate from the others.

Connect the communication cables to TB2 terminals 1 and 2 on outdoor unit A (main unit):

- Between the outdoor unit and the indoor unit.
- Between the outdoor unit and the CH unit.
- Between the outdoor unit and the indoor unit on other refrigeration cycles.


**CAUTION**

**Do not connect power cables to communication terminals (TB2). This could damage the circuit board.**

In heat recovery systems, connect the indoor unit communication cable (used exclusively for refrigeration) to TB2 terminals 1 and 2 on the CH unit.

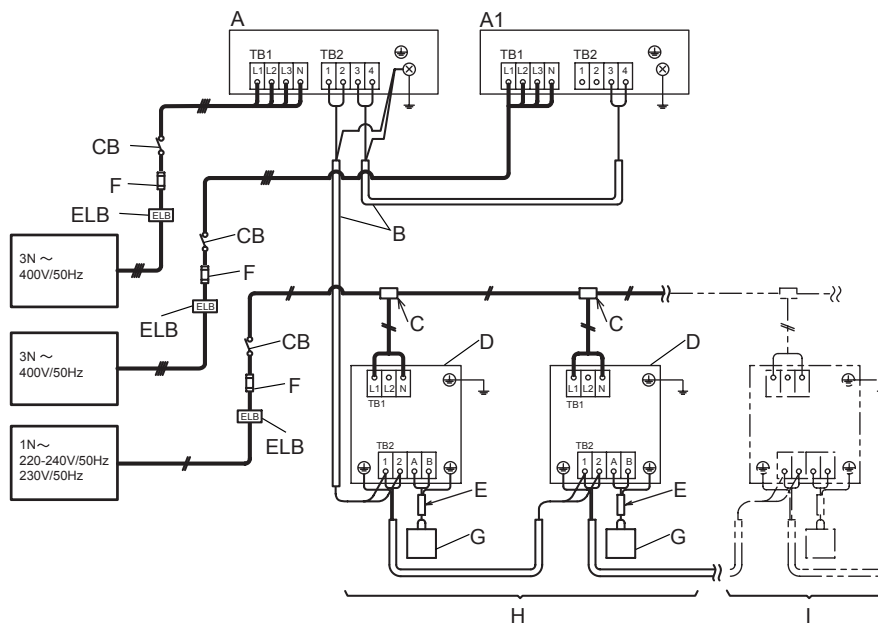
Connect the earthing cable for the outdoor units, the indoor units and the CH units. Earthing connections below a resistance of 100 Ω (max.) must be made by skilled personnel.


**NOTE**

- 1 **Set the DSW switches on the main and secondary units for the combination of (20-54) HP outdoor units.**
- 2 **An alarm is triggered if the communication cables between the outdoor units are connected to terminals 1 and 2 for H-LINK II.**
- 3 **Where an alarm is indicated on the display of the main outdoor unit, follow the instructions given to make the necessary checks.**
- 4 **Make the function settings from the main outdoor unit.**
- 5 **Maximum number of refrigeration groups with one remote control: 64.**

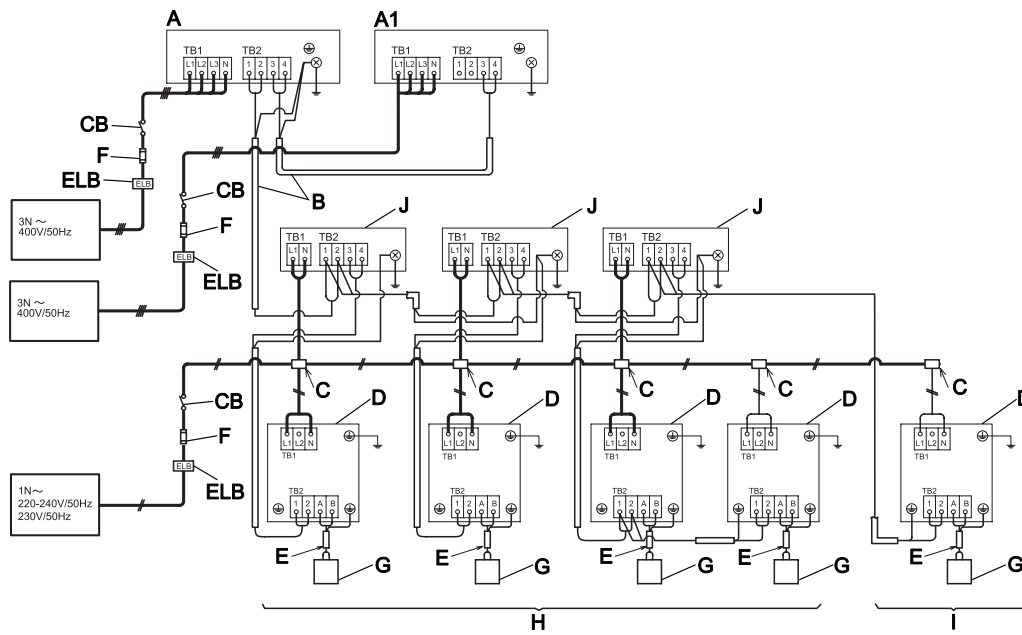
**Maximum number of indoor units connected: 160.**

## ◆ Connection diagram: heat pump system



A	Main outdoor unit
A1	Secondary outdoor unit
B	Operation wiring (shielded twisted pair cable or shielded pair cable) 5 Vdc non-polar H-LINK (field-supplied)
C	Distribution box (field-supplied)
D	Indoor units
E	Operation wiring (shielded twisted pair cable or shielded pair cable) (field-supplied)
F	Fuse (field-supplied)
G	PC-ART remote control
H	Indoor unit system No 0
I	Indoor unit system No 1
CB	Circuit breaker (field-supplied)
ELB	Earth Leakage Breaker (field-supplied)

◆ Connection diagram: heat recovery system



A	Main outdoor unit
A1	Secondary outdoor unit
B	Operation wiring (shielded twisted pair cable or shielded pair cable) 5 Vdc non-polar H-LINK (field-supplied)
C	Distribution box (field-supplied)
D	Indoor units
E	Operation wiring (shielded twisted pair cable or shielded pair cable) (field-supplied)
F	Fuse (field-supplied)
G	PC-ART remote control
H	Indoor unit system No 0
I	Indoor unit system No 1
J	CH unit
CB	Circuit breaker (field-supplied)
ELB	Earth Leakage Breaker (field-supplied)

## 10.5 Connection of the power supply circuits

### 10.5.1 Cable sizes

Model	Supply voltage	Maximum current (A)	Cross-section of the power cable		Cross-section of the service cable	
			EN60 335-1 (mm <sup>2</sup> ) <sup>(1)</sup>	MLFC (mm <sup>2</sup> ) <sup>(2)</sup>	EN60 335-1 (mm <sup>2</sup> ) <sup>(1)</sup>	MLFC (mm <sup>2</sup> ) <sup>(2)</sup>
RAS-8FSXN	3~ 400 V/50 Hz	12	2.5	2.0	0.75	0.75
RAS-10FSXN		16	2.5	2.0		
RAS-12FSXN		22	6	3.5		
RAS-14FSXN		26	6	5.5		
RAS-16FSXN		29	10	5.5		
RAS-18FSXN		31	10	8		

<sup>(1)</sup> The cross-sections of the cable should be selected for the maximum current of the unit, in accordance with European Standard EN60 335-1.

<sup>(2)</sup> The cross-sections of the cable have been selected for the maximum current of the unit, in accordance with cable MLFC (Flame Retardant Polyflex Wire) manufactured by HITACHI Cable Ltd., Japan.



#### NOTE

**Do not use cables that are lighter than the normal flexible coated polychloroprene cable (code H05RN-F).**

### 10.5.2 Main breaker switch

#### Indoor units

Model	Supply voltage	Maximum current (A)	ELB <sup>(1)</sup>		CB <sup>(2)</sup>
			Rated current (A)	Sensitivity (mA)	Rated current (A)
RAS-8FSXN	3~ 400 V, 50 Hz	12	40	30	20
RAS-10FSXN		16	40	30	20
RAS-12FSXN		22	40	30	30
RAS-14FSXN		26	40	30	40
RAS-16FSXN		29	63	30	40
RAS-18FSXN		31	63	30	50

<sup>(1)</sup> ELB: earth leakage breaker (field-supplied)

<sup>(2)</sup> CB: circuit breaker (field-supplied)

# 11. Optional functions

## Index

11.1	Optional functions available for outdoor units.....	238
------	---	-----

## 11.1 Optional functions available for outdoor units

Optional functions	
Optional function	Explanation
Fixing operation mode (Heating/Cooling)	This function sets the operating mode, heating or cooling. If heating (cooling) mode is set in the indoor unit when cooling (heating) mode is already set, the thermostat on this unit will be disabled.
Demand stoppage.	When this function is enabled, the compressor is stopped and the thermostat is switched off on the indoor units.
Outdoor unit fan motor stop/start (snow sensor)	This function starts all outdoor fans at full speed during compressor stoppage if the snow sensor is covered.
Forced stoppage	This function triggers an emergency stop. The compressor and indoor fans will not run.
Changeover of defrosting condition.	This function changes the defrost operating conditions. It is particularly useful in cold areas.
Demand current control.	This function sets the outdoor flow to 40%, 60%, 70%, 80%, 100%. If the flow demanded is above the flow set, the capacity of the indoor unit is reduced and the thermostat may even be disabled if necessary.
Forced noise reduction.	This function reduces the compressor and fan rotation frequency and, as a result, the sound level and capacity. (3 sound pressure level cases can be selected)
Indoor unit fan control during thermo-OFF at heating.	This function enables the fans in a cyclical manner (2 minutes on and 8 minutes off) to reduce the unpleasant aspects of operations with the indoor thermostat disabled.
Cancellation of heating outdoor ambient temperature limit.	This function allows for operations in heating mode with no restriction on the upper ambient temperature limit.
Cancellation of cooling outdoor ambient temperature limit.	This function allows for operations in cooling mode with no restriction on low ambient temperatures.
Night mode (low sound) operation.	This function decreases the sound level of the units and their cooling capacity.
Slow defrost setting.	When this function is enabled, the indoor fan speed in defrost mode switches to slow instead of stopping the fan.
Cancellation of outdoor Hot-start limit.	This function allows for the outdoor unit to be started without having to wait for the compressor temperature to exceed 40°C.
Wave function setting.	This function sets the outdoor flow. If the flow demanded is above the flow set, the capacity of the indoor unit is reduced and the thermostat may even be disabled if necessary. Control of the operating flow is not a set value and may vary within a range.
Low noise setting.	This function reduces the maximum speed of the fan motor and, therefore, decreases the noise level.
Cold draft.	The discharge air temperature of the indoor unit is also low, the outdoor unit is switching operating mode to prevent this low discharge air temperature.
Signal capture.	This function provides information on unit operations (operating mode, alarm, compressor on, defrost signals) so that the necessary devices can be enabled.

# 12. Location of problems

## Index

12.1	On-screen displays during abnormal operation.....	240
12.2	Alarm codes.....	241

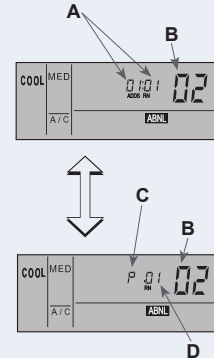
## 12.1 On-screen displays during abnormal operation

- Malfunction**  
 The RUN (red) indicator flashes.  
 The ALARM indicator appears on the liquid crystal display.  
 The screen also displays the indoor unit number -A-, the alarm code -B- and the model code -C-. If there are various indoor units connected, the above mentioned information is shown for each one of them -D-.  
 Write down the indications and contact your HITACHI service supplier.
- Power shortage**  
 All displays disappear.  
 If the unit stops due to a power shortage, it will not start again, even though the power comes back on. Carry out the start-up operations again.  
 If the power shortage lasts less than 2 seconds, the unit will start again automatically.
- Electrical noise**  
 The displays can disappear from the screen and the unit can stop. This is because the microcomputer has been activated to protect the unit from electrical noise.



### NOTE

***If the wireless remote control is used for the wall-type indoor unit, remove the connectors (CN25) that are connected to the indoor PCB. Otherwise the unit will not work. The stored data cannot be erased unless the remote control is initialised.***



Model code	
Indication	Model
H	Heat pump
P	Inverter
F	Multi (SET-FREE)
L	Refrigeration only
E	Other
b	Double, triple and quadruple



## 12.2 Alarm codes

Code	Category	Fault	Possible cause
01	Indoor unit	Protection device activation (float switch)	Float switch activation (high water level in drain pan or abnormality in drain pipe, float switch or drain pan).
02	Outdoor unit	Protection device activation (disconnection due to high pressure)	PSH activation (pipe blockage, excess refrigerant, mixture of inert gas).
03	Transmission	Abnormality between indoor and outdoor	Incorrect wiring, loose terminals, disconnect cable, blown fuse, outdoor unit switched off.
04		Abnormality between inverter PCB and outdoor PCB	Inverter PCB - Outdoor PCB transmission fault (loose connector, broken cable, blown fuse).
04.		Abnormality between fan controller and outdoor PCB	Fan controller - Outdoor PCB transmission fault (loose connector, broken cable, blown fuse).
05	Power phase	Abnormality in the power phases	Incorrect power supply, inverted phase connection, open phase.
06	Voltage	Abnormal inverter voltage	Outdoor voltage drop, insufficient power.
06.		Abnormal fan controller voltage	Outdoor voltage drop, insufficient power.
07	Cycle	Drop in discharge gas overheating	Excessive refrigerant charge, thermistor fault, incorrect wiring, incorrect pipe connection, expansion valve locked in open position (connector disconnected).
08		Increase in discharge gas temperature	Insufficient refrigerant charge, pipe blockage, thermistor fault, incorrect wiring, incorrect pipe connection, expansion valve locked in closed position (connector disconnected).
0A	Transmission	Abnormality between outdoor and indoor	Incorrect wiring, broken cable, loose terminals.
0b	Outdoor unit	Direction of the outdoor unit incorrectly set	Set direction of the outdoor units (secondary units) duplicated in the same refrigerant cycle system.
0C		Main unit of the outdoor unit incorrectly set	Two (or more) outdoor units defined as the "main unit" in the same refrigeration cycle system.
11	Indoor unit sensor	Air inlet thermistor	Incorrect wiring, disconnected wiring, broken cable, short circuit.
12		Air outlet thermistor	
13		Frost protection thermistor	
14		Gas pipe thermistor	
19	Fan motor	Indoor fan protection device activation	Fan motor overheating, locking.
21	Outdoor unit sensor	High-pressure sensor	Incorrect wiring, disconnected wiring, broken cable, short circuit.
22		Outdoor air thermistor	
23		Discharge gas thermistor at top of compressor	
24		Heat exchanger liquid pipe thermistor	
25		Heat exchanger gas pipe thermistor	
29		Low-pressure sensor	
31	System	Incorrect capacity setting on outdoor and indoor units	Combination capacity incorrectly set. Excessive or insufficient total indoor unit capacity.
35		Indoor unit no. incorrectly set	Indoor unit no. duplicated in same reference group.
38		Abnormality in the collection circuit for outdoor unit protection	Protection detection device fault (incorrect wiring of outdoor PCB).

Code	Category	Fault	Possible cause
39	Compressor	Abnormal operating current in constant speed compressor	Overcurrent, blown fuse, current sensor fault, instant power supply fault, voltage drop, abnormal power supply.
3A	Outdoor unit	Abnormal outdoor unit capacity.	Outdoor unit capacity > 54 HP.
3b		Voltage or combination of outdoor unit models incorrectly set	Voltage or combination of secondary and main units incorrectly set.
3d		Abnormal transmission between the main unit and the secondary unit(s)	Incorrect wiring, disconnected wiring, broken cable, PCB fault.
43	Protection device	Low-pressure decrease protection device activation	Defective compression (compressor or inverter fault, loose power supply connection).
44		Low-pressure increase protection device activation	Overload during cooling, high temperature with heating, locked expansion valve (loose connector).
45		High-pressure increase protection device activation	Overload (obstruction, short pitch), pipe blockage, excess refrigerant, mixture of inert gas.
47		Low-pressure decrease protection device activation (vacuum protection)	Insufficient refrigerant, refrigerant pipes, blockage, expansion valve locked in open position (loose connector).
48		Inverter overcurrent protection device activation	Overload, compressor fault.
51	Sensor	Abnormal inverter current sensor	Current sensor fault.
53	Inverter	Inverter error signal detection	Controller IC error signal detection (overcurrent, low-voltage and short-circuit protection).
54		Abnormal inverter fin temperature	Abnormal inverter fin thermistor, heat exchanger blockage, fan motor fault.
55		Inverter fault	Inverter PCB fault.
57	Fan controller	Fan controller protection activation	Controller IC error signal detection (overcurrent, low-voltage and short-circuit protection), instant overcurrent.
5A		Abnormal fan controller fin temperature	Fin thermistor fault, heat exchanger blockage, fan motor fault.
5b		Overcurrent protection activation	Fan motor fault.
5c		Abnormal fan controller sensor	Current sensor fault (instant overcurrent, increased fin temperature, low voltage, earthing fault, step-out).
EE	Compressor	Compressor protection alarm (cannot be reset from the remote controller)	This alarm code is displayed when the following alarms are triggered three times within six hours: 02, 07, 08, 39, 43 to 45, 47.
b1	Outdoor unit number setting	Unit number or direction number of the outdoor unit incorrectly set	A number greater than 64 has been set for the refrigerant cycle or direction.
b5	Indoor unit number setting	Connection number of the indoor unit incorrectly set	There are more than 17 units not corresponding to H-LINK II connected to one system.
C1	CH unit	Incorrect indoor unit connection	There are 2 or more CH units connected between the outdoor and indoor units.
C2		Connection number of the indoor unit incorrectly set	There are 9 or more indoor units connected to the CH unit
C3		Incorrect indoor unit connection	Indoor units from different refrigerant cycles have been connected to the CH unit.



Hitachi Air Conditioning Products Europe, S.A.  
Ronda Shimizu, 1 - Polig. Ind. Can Torrella  
08233 Vacarisses (Barcelona) Spain



Hitachi certifies that our products have met EU consumer safety, health and environmental requirements.



Hitachi Air Conditioning Products Europe, S.A. is certified with:  
ISO 9001 by AENOR, Spain for its Quality management as per Standard  
ISO 14001 by AENOR, Spain for its Environmental Management systems as per Standard



Hitachi air conditioning products are manufactured according to:  
ISO 9001 by JQA, Japan for its Quality Management as per Standard  
ISO 14001 by JACO, Japan for its Environmental Management systems as per Standard