

2. Dimensions

GUF-50RD3, GUF-100RD3

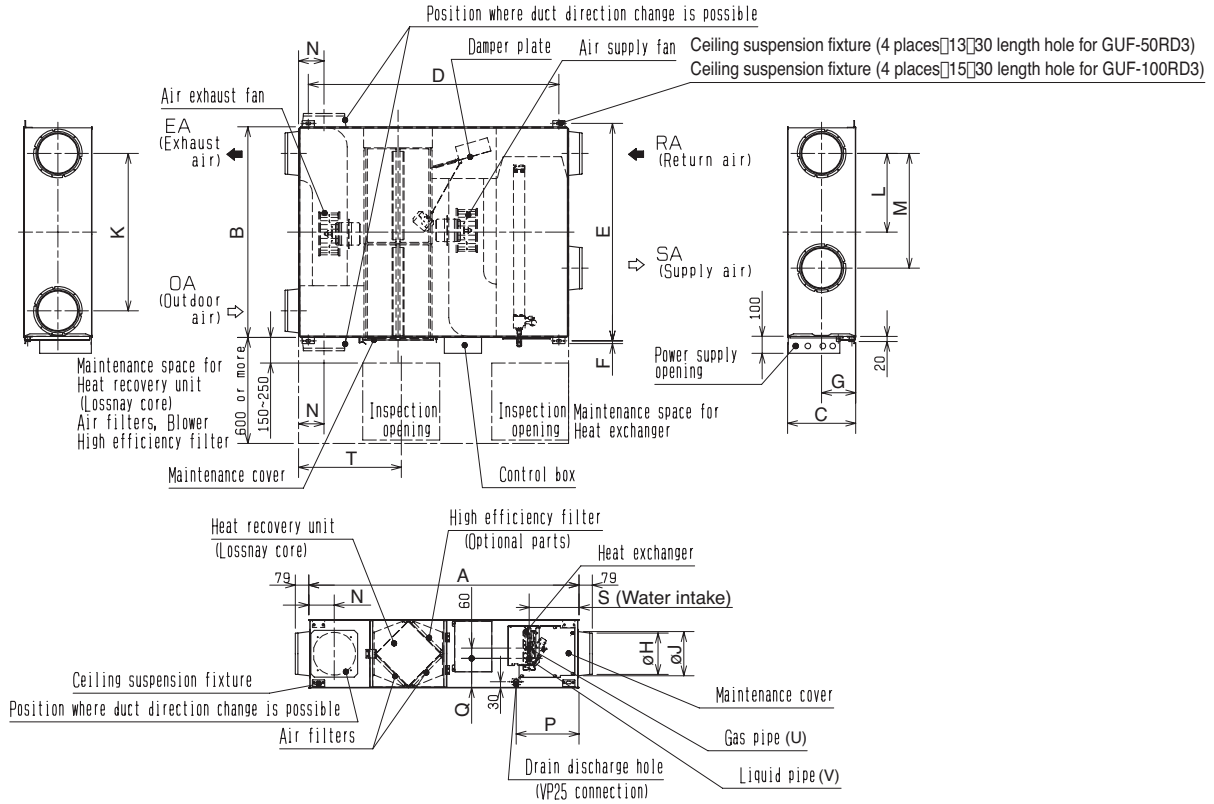

Model	External dimension			Ceiling suspension fixture pitch			Duct connection flange			Duct pitch				Humidification			Inspection opening	Flare		
	A	B	C	D	E	F	Nominal diameter	G	H	J	K	L	M	N	P	Q		S	T	U
GUF-50RD3	1288	1016	317	1185	1048	22	200	158.5	192	208	745	372.5	435	124	347	135	266	450	ø12.7	ø6.35
GUF-100RD3	1580	1231	398	1465	1271	16	250	199	242	258	920	460	670	149	361	169	280	600	ø15.88	ø9.52

Unit (mm)