

The Lossnay **GUG-01/02/03SL-E Air Processing DX Unit** works in conjunction with a Mr Slim outdoor unit to heat and cool the supply air from a Lossnay Mechanical Ventilation Heat Recovery (MVHR) unit.

The combination of these three products effectively creates an air handling system that can supply temperature controlled clean fresh air in a highly efficient manner.

### Key Features

- Provides heat recovery ventilation and air conditioning from the same ventilation system
- Air flow range from 500m<sup>3</sup>/hr. to 2500m<sup>3</sup>/hr
- Single system reduces installation time, costs and space
- Can be operated in supply air or return air control
- Built in drain pump to facilitate easy installation
- Single remote controller provides basic functions. PZ-61DR-E can be added for full functionality
- Available in 3 sizes, 01, 02 & 03



# GUG-01SL-E

## Connection to LGH-50RVX-E or LGH-65RVX-E

MODEL	GUG-01SL-E (Connection to LGH-50RVX-E or LGH-65RVX-E)
Refrigerant	R410A
Electrical power supply	220-240V / 50Hz, 220V / 60Hz (Supplied from outdoor unit)
Input power	Heating / Fan: 2.5W, Cooling: 12.4W
Running current	Less than 0.1A
Weight	21kg *Accessories: Approx. 1kg
Function	Heating / Cooling / Auto / Fan *Auto is only available for RA temperature control
	RA (Return Air) temperature control

RA (Return Air) temperature control		Connectable Lossnay unit LGH-50RVX-E	Connectable Lossnay unit LGH-65RVX-E
Capacity [kW]	Heating / Cooling	6.5 (2.4 + 4.1) / 5.6 (2.0 + 3.6)	7.7 (3.2 + 4.5) / 6.6 (2.6 + 4.0)
SHF		0.66	0.69
Performance index	Heating / Cooling	4.09 / 4.69	4.72 / 5.03
Air flow range at SP3 and SP4		350 - 695 m <sup>3</sup> /h	350 - 900 m <sup>3</sup> /h
Connectable outdoor unit		PUHZ-ZRP35	PUHZ-ZRP35
Ext. piping		Diameter Liquid / Gas: 6.35 / 12.7 Maximum length: 50m, Maximum height: 30m	Diameter Liquid / Gas: 6.35 / 12.7 Maximum length: 50m, Maximum height: 30m

Ventilation Specification		Connectable Lossnay unit LGH-50RVX-E				Connectable Lossnay unit LGH-65RVX-E			
Fan speed		SP4	SP3	SP2	SP1	SP4	SP3	SP2	SP1
Air volume	[m <sup>3</sup> /h]	500	375	250	125	650	488	325	163
	[L/s]	139	104	69	35	181	135	90	45
External static pressure [Pa]		105	59	26	7	95	53	24	6

### Notes:

**1.** The running current and input power are based on 230V/50Hz. **2.** The cooling and heating capacities are based on the air conditions listed below and the rated airflow of fan speed 4. Cooling Indoor: 27°CDB/19°CWB Outdoor: 35°CDB/24°CWB Heating Indoor: 20°CDB/15°CWB Outdoor: 7°CDB/6°CWB **3.** The first figure in ( ) of the capacity specification is the heat recovery energy of the Lossnay unit. The second figure is the capacity specification for the Dx-coil connected to the outdoor unit. **4.** "Performance index" is the calculated value at the temperature conditions above and is reference purpose only. Performance index = Total capacity ÷ total power consumption of outdoor unit and Lossnay unit **5.** The external static pressure listed above includes the static pressure loss of the Dx-coil unit when using a 50cm straight duct between the Lossnay and Dx-coil units. When the duct work between the Lossnay and Dx-coil units is longer and/or bent, the pressure loss of the duct work should be included in the pressure loss calculation. **6.** The designed airflow of the system (Lossnay, Dx-coil and duct work) at fan speed 3 and 4 should be kept within "Airflow range at SP3 and SP4" listed above. This range is shown as the green line in graphs of the characteristics curve. If the Lossnay airflow is out of this range, the compressor of the outdoor unit may stop for self-protection purposes. **7.** By installing the Dx-coil unit with a Lossnay unit, the air blow noise level is quieter at fan speed 4 as shown below. LGH-50RVX-E: about 4dB quieter, LGH-65RVX-E: about 7dB quieter. **8.** Refrigerant leakage contributes to climate change. Refrigerant with lower global warming potential (GWP) would contribute less to global warming than a refrigerant with higher GWP, if leaked to the atmosphere. This appliance contains a refrigerant fluid with a GWP equal to 1975. This means that if 1kg of this refrigerant fluid would be leaked to the atmosphere, the impact on global warming would be 1975 times higher than 1kg of CO<sub>2</sub>, over a period of 100 years. Never try to interfere with the refrigerant circuit yourself or disassemble the product yourself and always ask a professional.

### Fan Curve Characteristics

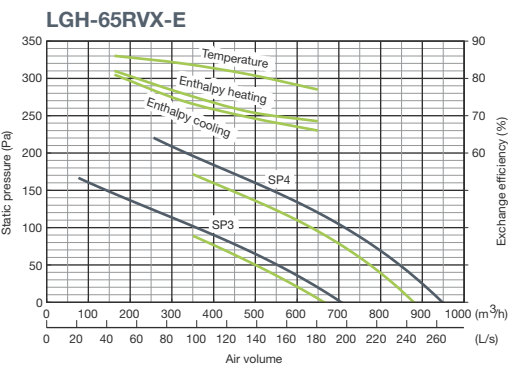
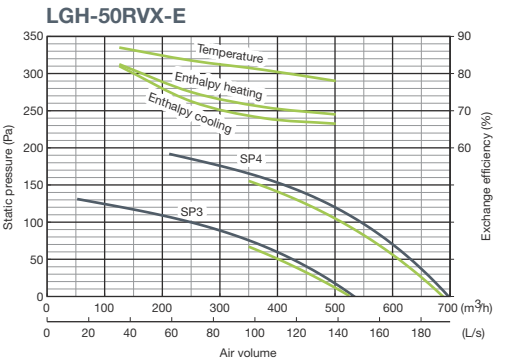

### Schematics

### GUG-01SL-E

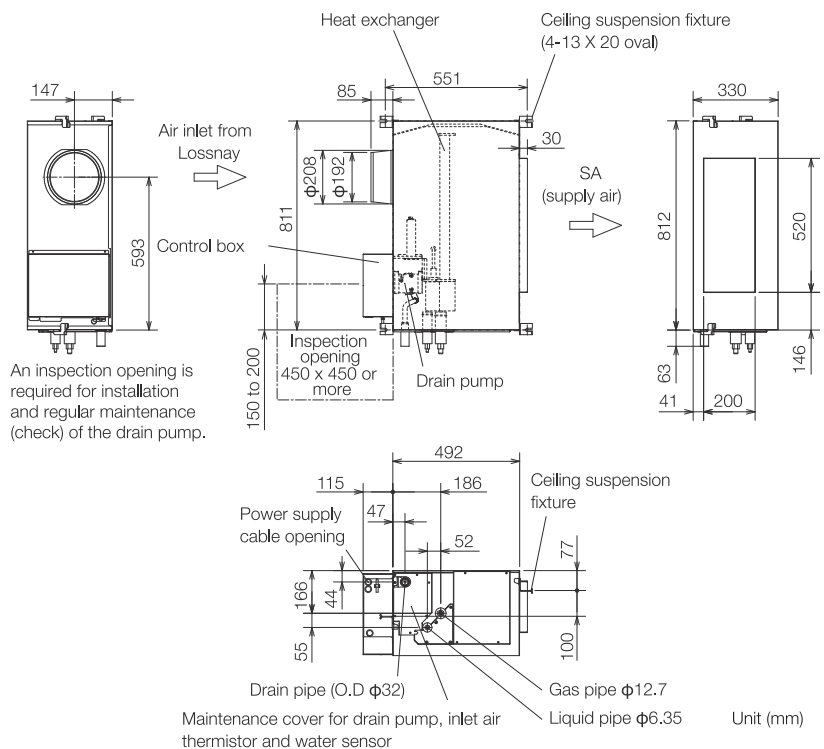

— With GUG-01SL-E — Without GUG-01SL-E

# GUG-02SL-E

## Connection to LGH-80RVX-E or LGH-100RVX-E

MODEL	GUG-02SL-E (Connection to LGH-80RVX-E or LGH-100RVX-E)	
Refrigerant	R410A	
Electrical power supply	220-240V / 50Hz, 220V / 60Hz (Supplied from outdoor unit)	
Input power	Heating / Fan: 2.5W, Cooling: 12.4W	
Running current	Less than 0.1A	
Weight	26kg *Accessories: Approx. 1kg	
Function	Heating / Cooling / Auto / Fan *Auto is only available for RA temperature control	
	RA (Return Air) temperature control / SA (Supply Air) temperature control [Must be set at initial setting and not possible to change from remote controller]	

RA (Return Air) temperature control		Connectable Lossnay unit LGH-80RVX-E	Connectable Lossnay unit LGH-100RVX-E
Capacity [kW]	Heating / Cooling	10.0 (4.0 + 6.0) / 8.3 (3.3 + 5.0)	13.2 (5.1 + 8.1) / 11.3 (4.2 + 7.1)
SHF		0.69	0.66
Performance index	Heating / Cooling	4.62 / 4.76	4.42 / 4.98
Air flow range at SP3 and SP4		560 - 1200 m <sup>3</sup> /h	700 - 1200 m <sup>3</sup> /h
Connectable outdoor unit		PUHZ-ZRP50	PUHZ-ZRP71
Ext. piping		Diameter Liquid / Gas: 6.35 / 12.7 Maximum length: 50m, Maximum height: 30m	Diameter Liquid / Gas: 9.52 / 15.88 Maximum length: 50m, Maximum height: 30m
Required optional parts		PAC-SH30RJ-E and PAC-SH50RJ-E	-

SA (Supply Air) temperature control		Connectable Lossnay unit LGH-80RVX-E	Connectable Lossnay unit LGH-100RVX-E
Capacity [kW]	Heating / Cooling	10.0 (4.0 + 6.0) / 8.3 (3.3 + 5.0)	11.4 (5.1 + 6.3) / 9.5 (4.2 + 5.3)
SHF		0.69	0.73
Performance index	Heating / Cooling	4.62 / 4.76	5.09 / 5.43
Air flow range at SP3 and SP4		560 - 1200 m <sup>3</sup> /h	700 - 1200 m <sup>3</sup> /h
Connectable outdoor unit		PUHZ-ZRP50	PUHZ-ZRP50
Ext. piping		Diameter Liquid / Gas: 6.35 / 12.7 Maximum length: 50m, Maximum height: 30m	Diameter Liquid / Gas: 6.35 / 12.7 Maximum length: 50m, Maximum height: 30m
Required optional parts		PAC-SH30RJ-E and PAC-SH50RJ-E	PAC-SH30RJ-E and PAC-SH50RJ-E

Ventilation Specification		Connectable Lossnay unit LGH-80RVX-E				Connectable Lossnay unit LGH-100RVX-E			
Fan speed		SP4	SP3	SP2	SP1	SP4	SP3	SP2	SP1
Air volume	[m <sup>3</sup> /h]	800	600	400	200	1,000	750	500	250
	[L/s]	222	167	111	56	278	208	139	69
External static pressure [Pa]		130	73	33	8	130	73	33	8

### Notes:

1. The running current and input power are based on 230V/50Hz. 2. The cooling and heating capacities are based on the air conditions listed below and the rated airflow of fan speed 4. Cooling Indoor: 27°CDB/19°CWB Outdoor: 35°CDB/24°CWB Heating Indoor: 20°CDB/15°CWB Outdoor: 7°CDB/6°CWB 3. The first figure in ( ) of the capacity specification is the heat recovery energy of the Lossnay unit. The second figure is the capacity specification for the Dx-coil connected to the outdoor unit. 4. "Performance index" is the calculated value at the temperature conditions above and is reference purpose only. Performance index = Total capacity ÷ total power consumption of outdoor unit and Lossnay unit. 5. The external static pressure listed above includes the static pressure loss of the Dx-coil unit when using a 50cm straight duct between the Lossnay and Dx-coil units. When the duct work between the Lossnay and Dx-coil units is longer and/or bent, the pressure loss of the duct work should be included in the pressure loss calculation. 6. The designed airflow of the system (Lossnay, Dx-coil and duct work) at fan speed 3 and 4 should be kept within "Airflow range at SP3 and SP4" listed above. This range is shown as the green line in graphs of the characteristics curve. If the Lossnay airflow is out of this range, the compressor of the outdoor unit may stop for self-protection purposes. 7. By installing the Dx-coil unit with a Lossnay unit, the air blow noise level is quieter at fan speed 4 as shown below. LGH-80RVX-E: about 6dB quieter, LGH-100RVX-E: about 7dB quieter. 8. Refrigerant leakage contributes to climate change. Refrigerant with lower global warming potential (GWP) would contribute less to global warming than a refrigerant with higher GWP, if leaked to the atmosphere. This appliance contains a refrigerant fluid with a GWP equal to 1975. This means that if 1kg of this refrigerant fluid would be leaked to the atmosphere, the impact on global warming would be 1975 times higher than 1kg of CO<sub>2</sub>, over a period of 100 years. Never try to interfere with the refrigerant circuit yourself or disassemble the product yourself and always ask a professional.

### Fan Curve Characteristics

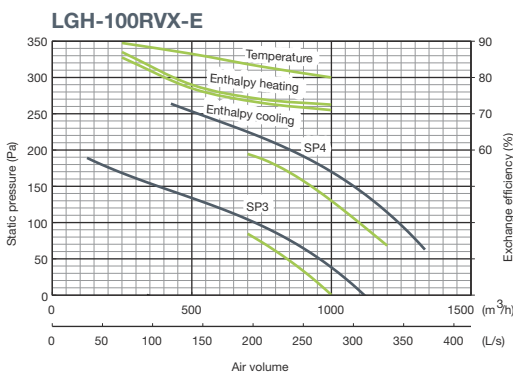
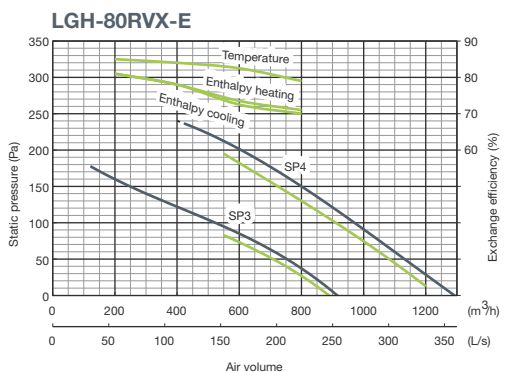

### Schematics

### GUG-02SL-E

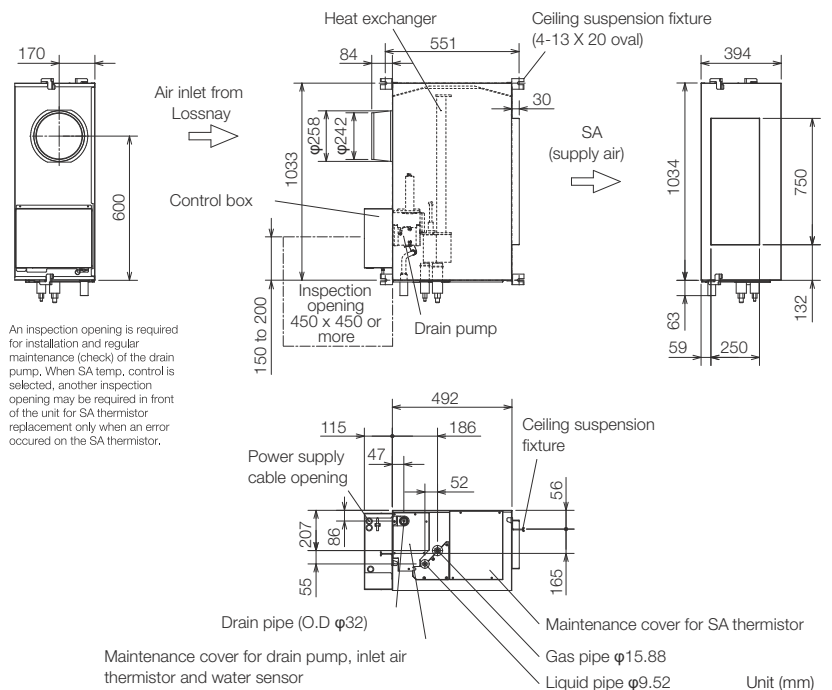

— With GUG-02SL-E — Without GUG-02SL-E

Unit (mm)

# GUG-03SL-E

## Connection to LGH-150RVX-E or LGH-200RVX-E

MODEL	GUG-03SL-E (Connection to LGH-150RVX-E or LGH-200RVX-E)
Refrigerant	R410A
Electrical power supply	220-240V / 50Hz, 220V / 60Hz (Supplied from outdoor unit)
Input power	Heating / Fan: 2.5W, Cooling: 12.4W
Running current	Less than 0.1A
Weight	28kg *Accessories: Approx. 1kg
Function	Heating / Cooling / Auto / Fan *Auto is only available for RA temperature control
	RA (Return Air) temperature control / SA (Supply Air) temperature control [Must be set at initial setting and not possible to change from remote controller]

RA (Return Air) temperature control		Connectable Lossnay unit LGH-150RVX-E	Connectable Lossnay unit LGH-200RVX-E
Capacity [kW]	Heating / Cooling	20.7 (7.7 + 13.0) / 15.8 (6.3 + 9.5)	23.8 (10.3 + 13.5) / 18.4 (8.4 + 10.0)
SHF		0.68	0.76
Performance index	Heating / Cooling	4.24 / 5.27	5.02 / 5.86
Air flow range at SP3 and SP4		1050 - 2250 m <sup>3</sup> /h	1050 - 2600 m <sup>3</sup> /h
Connectable outdoor unit		PUHZ-ZRP100	PUHZ-ZRP100
Ext. piping		Diameter Liquid / Gas: 9.52 / 15.88 Maximum length: 75m, Maximum height: 30m	Diameter Liquid / Gas: 9.52 / 15.88 Maximum length: 75m, Maximum height: 30m

SA (Supply Air) temperature control		Connectable Lossnay unit LGH-150RVX-E	Connectable Lossnay unit LGH-200RVX-E
Capacity [kW]	Heating / Cooling	16.6 (7.7 + 8.9) / 13.4 (6.3 + 7.1)	19.5 (10.3 + 9.2) / 15.9 (8.5 + 7.4)
SHF		0.85	0.90
Performance index	Heating / Cooling	5.46 / 5.32	6.30 / 5.85
Air flow range at SP3 and SP4		1050 - 2250 m <sup>3</sup> /h	1050 - 2600 m <sup>3</sup> /h
Connectable outdoor unit		PUHZ-ZRP71	PUHZ-ZRP71
Ext. piping		Diameter Liquid / Gas: 9.52 / 15.88 Maximum length: 50m, Maximum height: 30m	Diameter Liquid / Gas: 9.52 / 15.88 Maximum length: 50m, Maximum height: 30m

Ventilation Specification		Connectable Lossnay unit LGH-150RVX-E				Connectable Lossnay unit LGH-200RVX-E			
Fan speed		SP4	SP3	SP2	SP1	SP4	SP3	SP2	SP1
Air volume	[m <sup>3</sup> /h]	1,500	1,125	750	375	2,000	1,500	1,000	500
	[L/s]	417	313	208	104	556	417	278	139
External static pressure [Pa]		150	84	38	9	105	59	26	7

### Notes:

1. The running current and input power are based on 230V/50Hz. 2. The cooling and heating capacities are based on the air conditions listed below and the rated airflow of fan speed 4. Cooling Indoor: 27°CDB/19°CWB Outdoor: 35°CDB/24°CWB Heating Indoor: 20°CDB/15°CWB Outdoor: 7°CDB/6°CWB 3. The first figure in ( ) of the capacity specification is the heat recovery energy of the Lossnay unit. The second figure is the capacity specification for the Dx-coil connected to the outdoor unit. 4. "Performance index" is the calculated value at the temperature conditions above and is reference purpose only. Performance index = Total capacity ÷ total power consumption of outdoor unit and Lossnay unit. 5. The external static pressure listed above includes the static pressure loss of the Dx-coil unit when using a 50cm straight duct between the Lossnay and Dx-coil units. When the duct work between the Lossnay and Dx-coil units is longer and/or bent, the pressure loss of the duct work should be included in the pressure loss calculation. 6. The designed airflow of the system (Lossnay, Dx-coil and duct work) at fan speed 3 and 4 should be kept within "Airflow range at SP3 and SP4" listed above. This range is shown as the green line in graphs of the characteristics curve. If the Lossnay airflow is out of this range, the compressor of the outdoor unit may stop for self-protection purposes. 7. By installing the Dx-coil unit with a Lossnay unit, the air blow noise level is quieter at fan speed 4 as shown below. LGH-150,200RVX-E: about 3dB quieter. 8. Refrigerant leakage contributes to climate change. Refrigerant with lower global warming potential (GWP) would contribute less to global warming than a refrigerant with higher GWP, if leaked to the atmosphere. This appliance contains a refrigerant fluid with a GWP equal to 1975. This means that if 1kg of this refrigerant fluid would be leaked to the atmosphere, the impact on global warming would be 1975 times higher than 1kg of CO<sub>2</sub>, over a period of 100 years. Never try to interfere with the refrigerant circuit yourself or disassemble the product yourself and always ask a professional.

## Fan Curve Characteristics

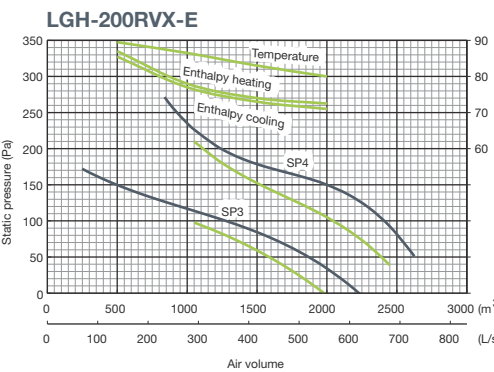
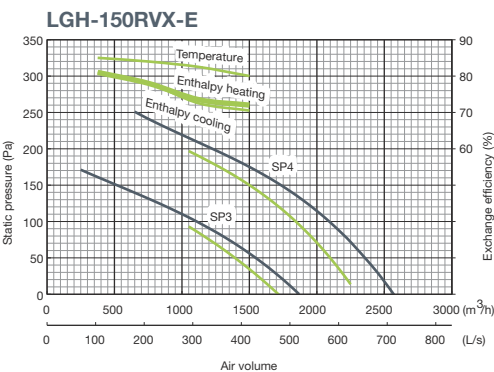

— With GUG-03SL-E — Without GUG-03SL-E

## Schematics

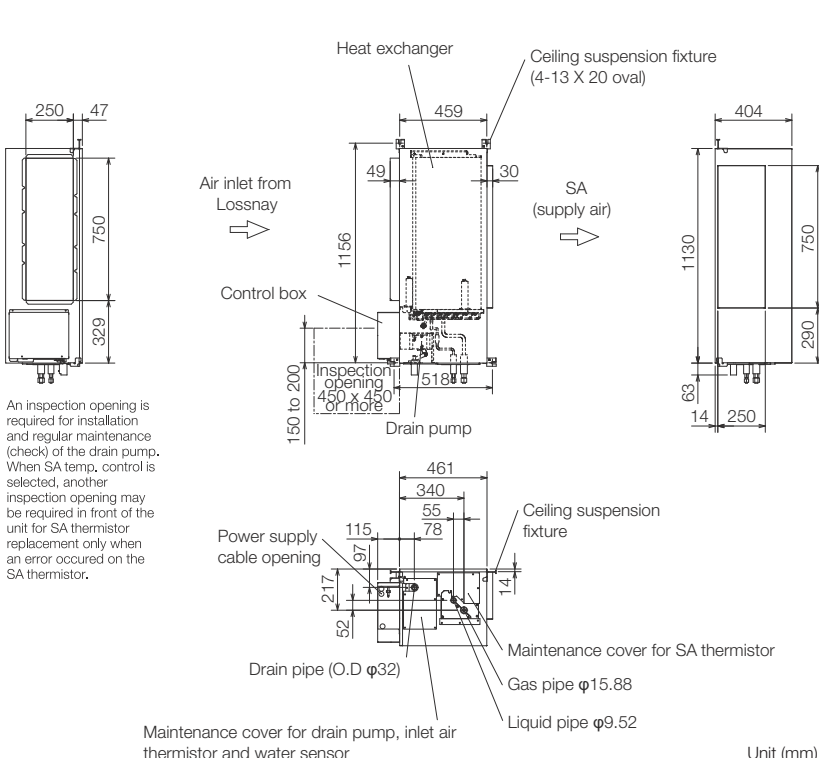

An inspection opening is required for installation and regular maintenance (check) of the drain pump. When SA temp. control is selected, another inspection opening may be required in front of the unit for SA thermistor replacement only when an error occurred on the SA thermistor.

Unit (mm)

# GUG-03SL-E

Connection to LGH-150RVXT-E, LGH-200RVXT-E or LGH-250RVXT-E

MODEL	GUG-03SL-E (Connection to LGH-150RVXT-E, LGH-200RVXT-E or LGH-250RVXT-E)
Refrigerant	R410A
Electrical power supply	220-240V / 50Hz, 220V / 60Hz (Supplied from outdoor unit)
Input power	Heating / Fan: 2.5W, Cooling: 12.4W
Running current	Less than 0.1A
Weight	28kg *Accessories: Approx. 1kg
Function	Heating / Cooling / Auto / Fan *Auto is only available for RA temperature control RA (Return Air) temperature control / SA (Supply Air) temperature control [Must be set at initial setting and not possible to change from remote controller]

RA (Return Air) temperature control		Connectable Lossnay unit LGH-150RVXT-E	Connectable Lossnay unit LGH-200RVXT-E	Connectable Lossnay unit LGH-250RVXT-E
Capacity [kW]	Heating / Cooling	20.4 ( 7.4 + 13.0 ) / 15.7 ( 6.2 + 9.5 )	23.8 ( 10.3 + 13.5 ) / 18.4 ( 8.4 + 10.0 )	26.1 ( 12.1 + 14.0 ) / 22.3 ( 9.8 + 12.5 )
SHF		0.68	0.76	0.87
Performance index	Heating / Cooling	4.07 / 5.03	4.86 / 5.59	4.75 / 4.59
Air flow range at SP3 and SP4		1050 - 2250 m <sup>3</sup> /h	1050 - 2600 m <sup>3</sup> /h	1750 - 2880 m <sup>3</sup> /h
Connectable outdoor unit		PUHZ-ZRP100	PUHZ-ZRP100	PUHZ-ZRP125
Ext. piping		Diameter Liquid / Gas: 9.52 / 15.88 Maximum length: 75m, Maximum height: 30m	Diameter Liquid / Gas: 9.52 / 15.88 Maximum length: 75m, Maximum height: 30m	Diameter Liquid / Gas: 9.52 / 15.88 Maximum length: 75m, Maximum height: 30m

SA (Supply Air) temperature control		Connectable Lossnay unit LGH-150RVXT-E	Connectable Lossnay unit LGH-200RVXT-E	Connectable Lossnay unit LGH-250RVXT-E
Capacity [kW]	Heating / Cooling	16.3 ( 7.4 + 8.9 ) / 13.3 ( 6.2 + 7.1 )	19.5 ( 10.3 + 9.2 ) / 15.9 ( 8.5 + 7.4 )	21.6 ( 12.1 + 9.5 ) / 17.6 ( 9.8 + 7.8 )
SHF		0.86	0.90	0.95
Performance index	Heating / Cooling	5.16 / 5.03	6.01 / 5.54	5.97 / 5.31
Air flow range at SP3 and SP4		1050 - 2250 m <sup>3</sup> /h	1050 - 2600 m <sup>3</sup> /h	1000 - 2600 m <sup>3</sup> /h
Connectable outdoor unit		PUHZ-ZRP71	PUHZ-ZRP71	PUHZ-ZRP71
Ext. piping		Diameter Liquid / Gas: 9.52 / 15.88 Maximum length: 50m, Maximum height: 30m	Diameter Liquid / Gas: 9.52 / 15.88 Maximum length: 50m, Maximum height: 30m	Diameter Liquid / Gas: 9.52 / 15.88 Maximum length: 50m, Maximum height: 30m

Ventilation Specification		Connectable Lossnay unit LGH-150RVXT-E				Connectable Lossnay unit LGH-200RVXT-E				Connectable Lossnay unit LGH-250RVXT-E			
Fan speed		SP4	SP3	SP2	SP1	SP4	SP3	SP2	SP1	SP4	SP3	SP2	SP1
Air volume	[m <sup>3</sup> /h]	1,500	1,125	750	375	2,000	1,500	1,000	500	2,500	1,875	1,250	625
	[L/s]	417	313	208	104	556	417	278	139	694	521	347	174
External static pressure [Pa]		150	84	38	9	145	82	36	9	140	79	35	9

## Notes:

1. The running current and input power are based on 230V/50Hz. 2. The cooling and heating capacities are based on the air conditions listed below and the rated airflow of fan speed 4. Cooling Indoor: 27°CDB/19°CWB Outdoor: 35°CDB/24°CWB Heating Indoor: 20°CDB/15°CWB Outdoor: 7°CDB/6°CWB 3. The first figure in ( ) of the capacity specification is the heat recovery energy of the Lossnay unit. The second figure is the capacity specification for the Dx-coil connected to the outdoor unit. 4. "Performance index" is the calculated value at the temperature conditions above and is reference purpose only. Performance index = Total capacity ÷ total power consumption of outdoor unit and Lossnay unit. 5. The external static pressure listed above includes the static pressure loss of the Dx-coil unit when using a 50cm straight duct between the Lossnay and Dx-coil units. When the duct work between the Lossnay and Dx-coil units is longer and/or bent, the pressure loss of the duct work should be included in the pressure loss calculation. 6. The designed airflow of the system (Lossnay, Dx-coil and duct work) at fan speed 3 and 4 should be kept within "Airflow range at SP3 and SP4" listed above. This range is shown as the green line in graphs of the characteristics curve. If the Lossnay airflow is out of this range, the compressor of the outdoor unit may stop for self-protection purposes. 7. By installing the Dx-coil unit with a Lossnay unit, the air blow noise level is quieter at fan speed 4 as shown below. LGH-150,200RVXT-E: about 3dB quieter, LGH-250RVXT-E: about 4dB quieter. 8. Refrigerant leakage contributes to climate change. Refrigerant with lower global warming potential (GWP) would contribute less to global warming than a refrigerant with higher GWP, if leaked to the atmosphere. This appliance contains a refrigerant fluid with a GWP equal to 1975. This means that if 1kg of this refrigerant fluid would be leaked to the atmosphere, the impact on global warming would be 1975 times higher than 1kg of CO<sub>2</sub> over a period of 100 years. Never try to interfere with the refrigerant circuit yourself or disassemble the product yourself and always ask a professional.

## Fan Curve Characteristics

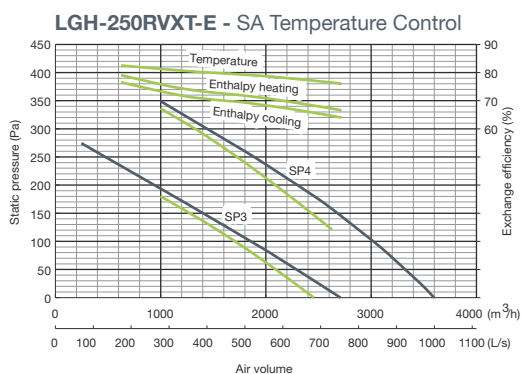
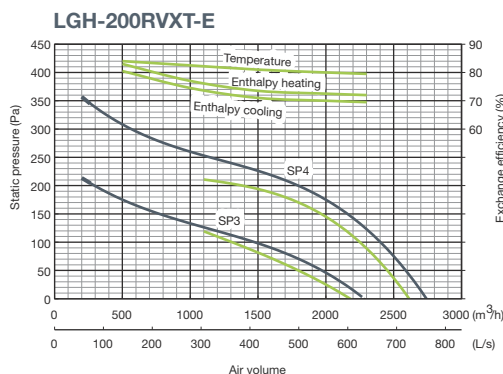
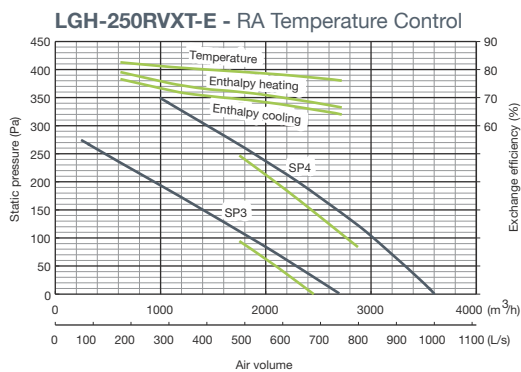
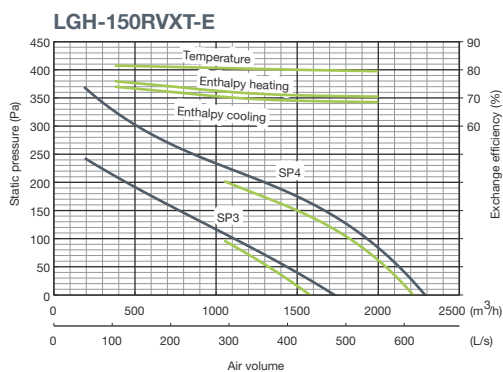

— With GUG-03SL-E — Without GUG-03SL-E

# Ideal for commercial applications including offices and schools:

## Office application

## Supplemented air conditioning system

RA Temperature Control - Temperature setting range

- Heating: 17-28°C
- Cooling: 19-30°C
- Auto: 19-28°C

Supplemental air conditioning systems that combine the use of Dx-coil and Lossnay MVHR units are now possible.

Fresh air volume requirement	Medium
Heating and cooling capacity requirement	High

Target Segment:

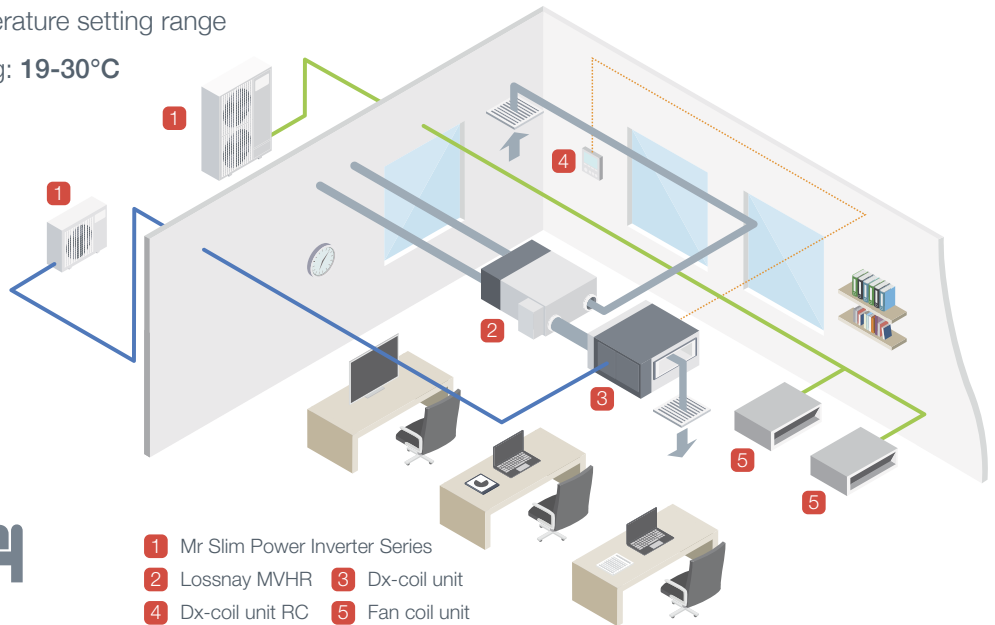

- 1 Mr Slim Power Inverter Series
- 2 Lossnay MVHR
- 3 Dx-coil unit
- 4 Dx-coil unit RC
- 5 Fan coil unit

## School application

## Main air conditioning system

RA Temperature Control - Temperature setting range

- Heating: 17-28°C
- Cooling: 19-30°C
- Auto: 19-28°C

If the required heating and cooling capacity is not so high, a Dx-coil and Lossnay package solution is possible for air-conditioning and ventilation needs.

Fresh air volume requirement	High
Heating and cooling capacity requirement	Medium

Target Segment:

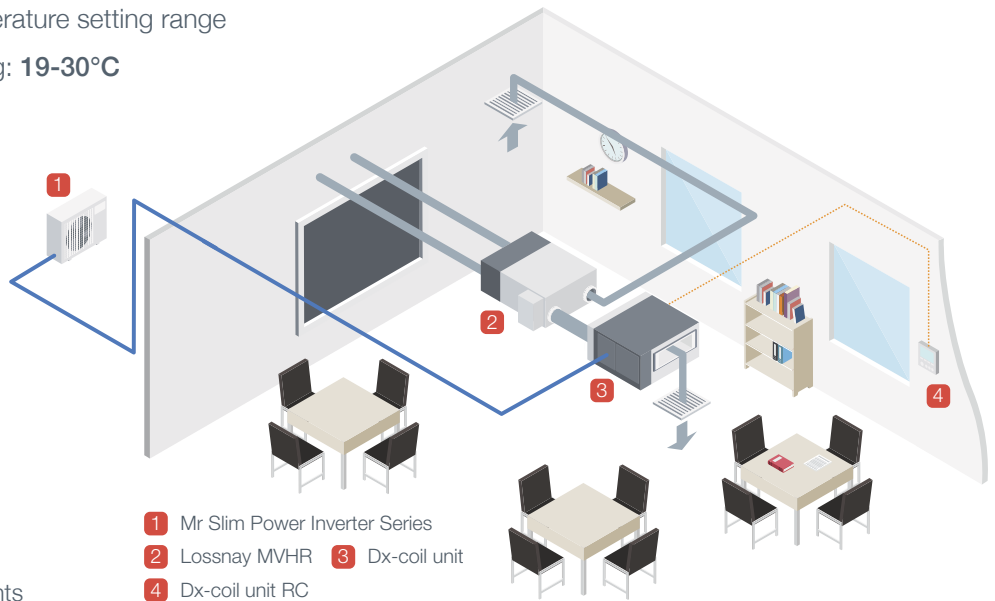

- 1 Mr Slim Power Inverter Series
- 2 Lossnay MVHR
- 3 Dx-coil unit
- 4 Dx-coil unit RC



Telephone: 01707 282880

email: ventilation@meuk.mee.com web: www.airconditioning.mitsubishielectric.co.uk

UNITED KINGDOM Mitsubishi Electric Europe Living Environmental Systems Division  
Travellers Lane, Hatfield, Hertfordshire, AL10 8XB, England General Enquiries Telephone: 01707 282880 Fax: 01707 278881

IRELAND Mitsubishi Electric Europe Westgate Business Park, Ballymount, Dublin 24, Ireland  
Telephone: Dublin (01) 419 8800 Fax: Dublin (01) 419 8890 International code: (003531)

Country of origin: United Kingdom – Japan – Thailand – Malaysia. ©Mitsubishi Electric Europe 2016. Mitsubishi and Mitsubishi Electric are trademarks of Mitsubishi Electric Europe B.V. The company reserves the right to make any variation in technical specification to the equipment described, or to withdraw or replace products without prior notification or public announcement. Mitsubishi Electric is constantly developing and improving its products. All descriptions, illustrations, drawings and specifications in this publication present only general particulars and shall not form part of any contract. All goods are supplied subject to the Company's General Conditions of Sale, a copy of which is available on request. Third-party product and brand names may be trademarks or registered trademarks of their respective owners.



Note: The fuse rating is for guidance only. Please refer to the relevant databook for detailed specification. It is the responsibility of a qualified electrician/electrical engineer to select the correct cable size and fuse rating based on current regulation and site specific conditions. Mitsubishi Electric's air conditioning and heat pump systems contain fluorinated greenhouse gases R410A, R407C and R134a.



www.greengateway.mitsubishielectric.co.uk  
Mitsubishi Electric UK's commitment to the environment

Follow us @meuk\_Jes  
Follow us @green\_gateway

Mitsubishi Electric  
Living Environmental Systems UK

mitsubishielectric2

Printed in October 2016  
SAP No. 298539